

## R8C/33T Group

R01AN0508EJ0100

Rev.1.00

Development case of LED dimmer by PWM with touch detecting

Jan 31, 2011

### Summary

Touch panel microcomputer R8C/33T group builds hardware (SCU: sensor control unit) that perceives the contact of the human body by measuring the stray capacity generated between the touch electrode and the human body into.

In this application note, we explain the touch board artwork technique to reduce the influence from LED drive and the other noise as much as possible.

### Target device

R8C/33T group

### Contents

1. Artwork and measurement operation .....	2
2. Reducing the parasitic capacitance .....	4
3. Parasitic capacitance change in electrode signal line.....	6
4. Development case.....	9
Website and Support.....	11
Revision Record .....	11
General Precautions in the Handling of MPU/MCU Products .....	12

# 1. Artwork and measurement operation

## 1.1 Outline

The SCU built in R8C/3xT detects the touch or not measuring the parasitic capacitance of the electrode and its wire. The parasitic capacitance of the electrode and its wire is changed to get the influence from all wired conductors around them.

The nearby GND pattern makes touch sensitivity down because of increasing the parasitic capacitance, and the signal lines along the electrode wires make the lines of electrodes noisy because of appearing capacitance coupling between them. It is important to arrange the lines of the electrodes correctly when the lines of the LED or the actuator plus drive are nearby them.

## 1.2 Occurrence of influence by LED drive

Figure 1-1 and Figure 1-3 show the influence of the plus drive line along the electrode's line as one example of LED drive. When the circuit of Figure 1-1 is composed as the artwork of Figure 1-2, the parasitic capacitance that the electrode signal lines receive increases the amount of the parasitic capacitance between the electrodes signal lines and LED drive lines. The added parasitic capacitance depends on the interval and side by side length of them.

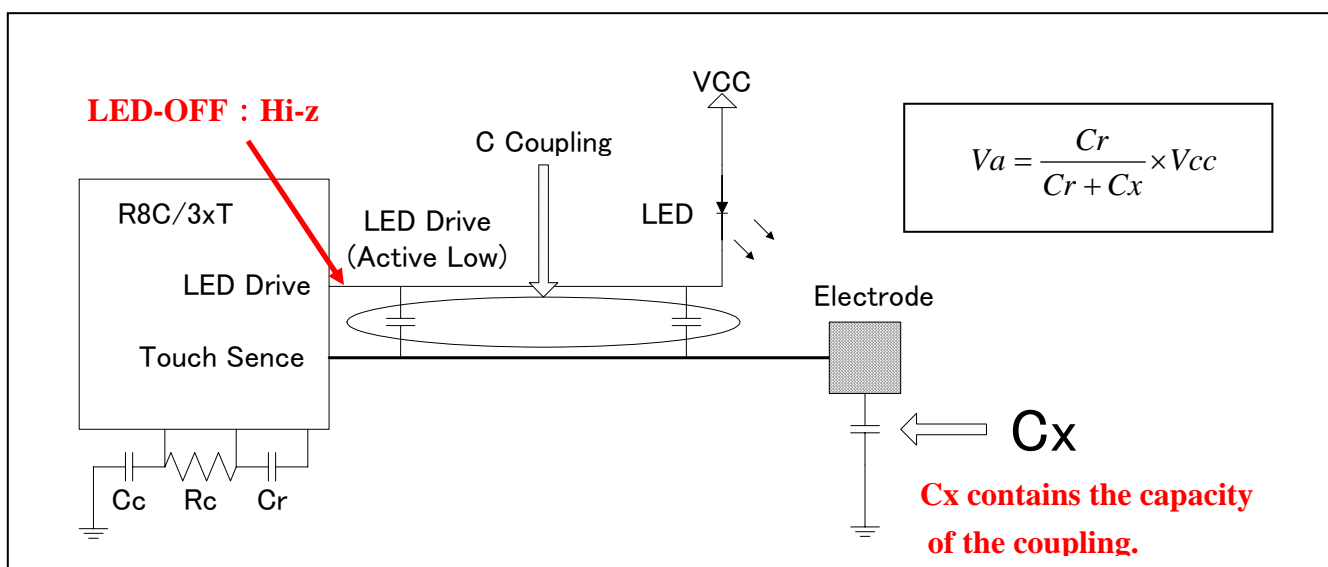

Figure 1-1 Influence when electrode signal line runs side by side with other signal wires

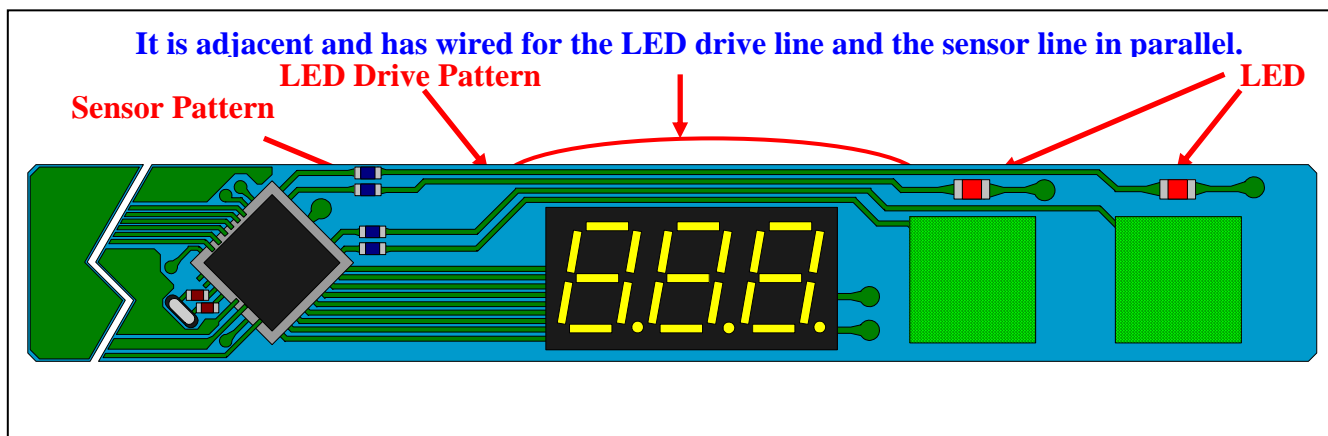

Figure 1-2 When the electrode signal line runs side by side with other signal wires (example of the artwork)

When LED is ON

When LED is ON (active Low), the LED signal line is GND level.

This is as same as GND pattern around the electrodes measurement line, as the result the parasitic capacitance of the electrode measurement lines increase.

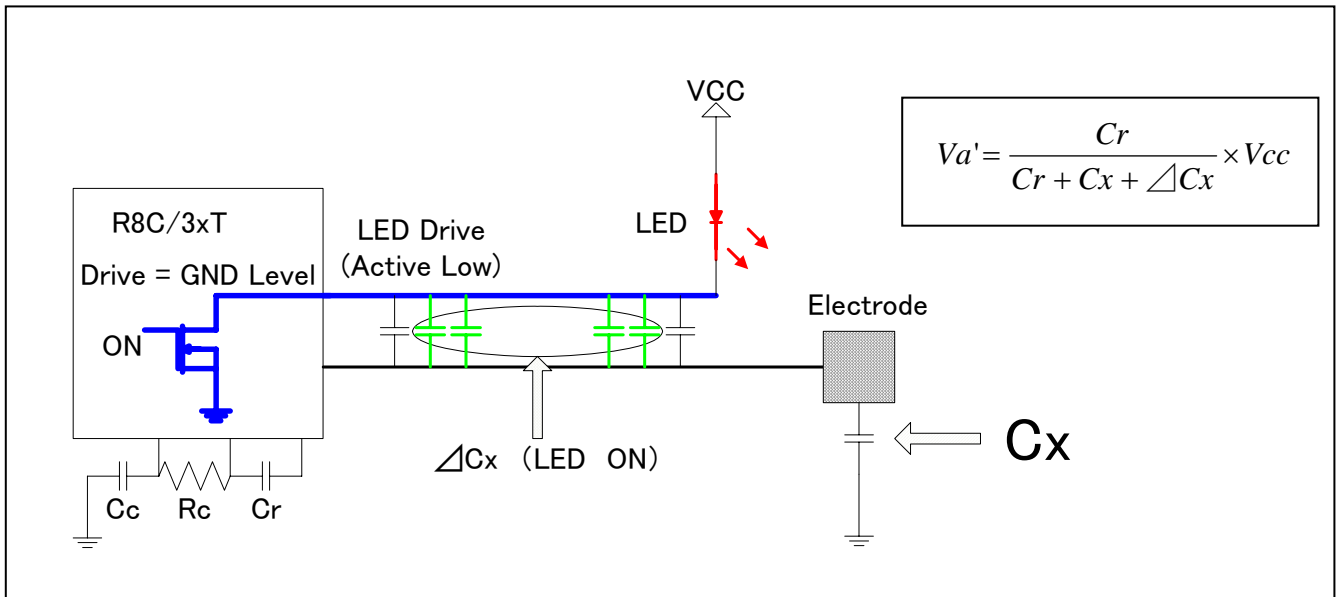

Figure 1-3 Influence when electrode signal line runs side by side with other signal wires (LED is ON)

A parasitic capacitance increase in the measurement line by the LED lighting influences the touch measurement result. In the situation in which "Hi-z" / "Low" is repeated alternately repeated by the PWM control, The movement of the touch measurement will synchronize it. (Change of measurement result -> Noise)  
 It may be influenced to the sensitivity of the touch if the count value difference is small (ex. Noise margin is small and multiplying the count value) and the parasitic capacitance value change (by the LED lighting) is large.

To avoid such a situation, the artwork becomes important.

## 2. Reducing the parasitic capacitance

### 2.1 Artwork

In the touch sensor, the sensitivity and the S/N characteristic of the sensor change by the arrangement of the pattern around the electrode signal line situation.

The surrounding of the electrode signal lines are preferable as much as possible other patterns and separated things, and when the signal that changes like the LED drive lines are adjoined, exemplifies it as follows.

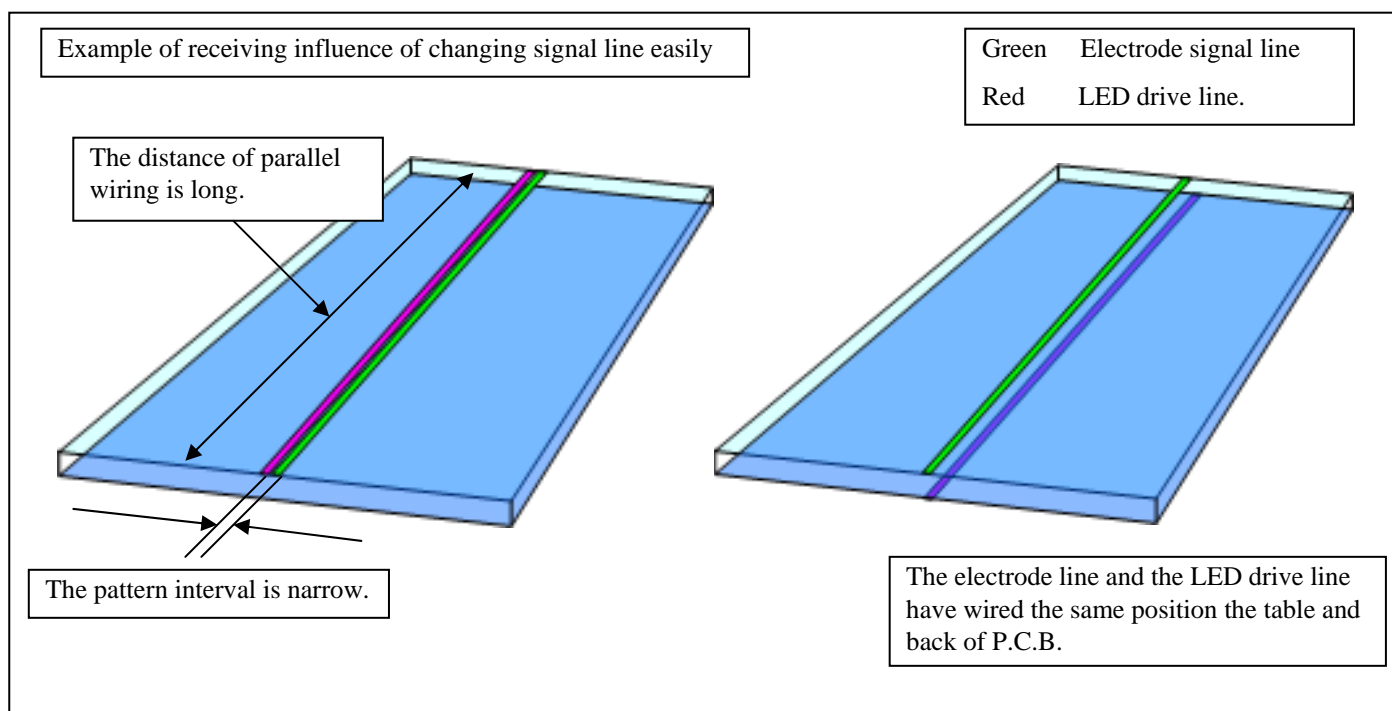

Figure 2-1 Example of LED drive line's influencing electrode signal line easily

When the LED line becomes "Low" level (GND potential), Figure 2-1 shows the example of increasing the parasitic capacitance value of the electrode signal line easily.

The increasing parasitic capacitance value is proportional to the length wired for in parallel with the interval between the electrode line and the LED drive line.

The parasitic capacitance change in the electrode signal line increases when similarly wiring by both sides of P.C.B.

It is necessary to avoid the above-mentioned artwork as much as possible for the S/N improvement of the touch sensor.

Next, a preferable example is shown for the electrode signal line.

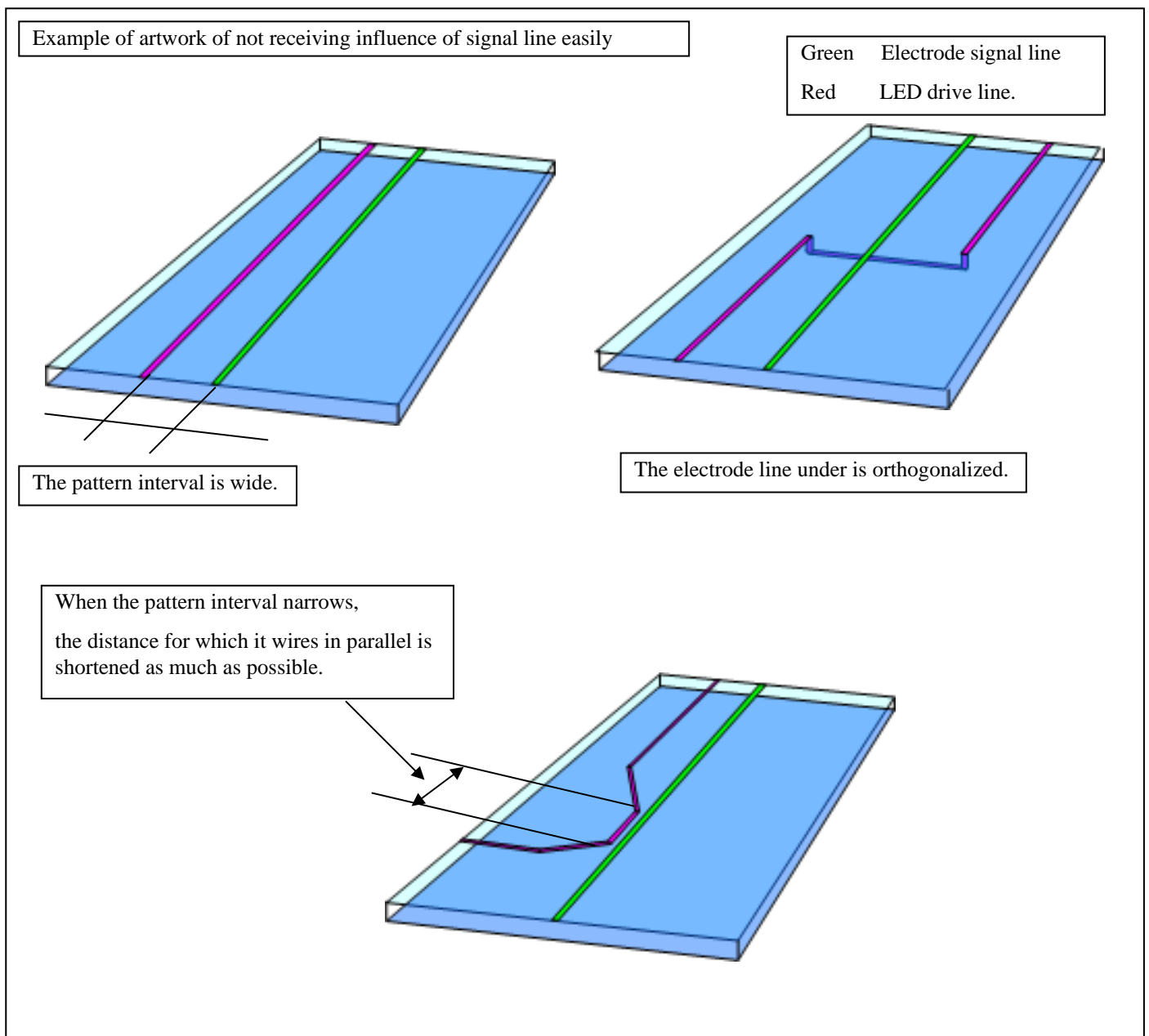

Figure 2-2 Example of LED drive line's not influencing electrode signal line easily

When the surrounding of the electrode signal line is overcrowded by the restriction of the artwork (P.C.B. size and circuit size, etc.)

The LED drive line etc. should not arrange the electrode signal line in the next soon.

Please consider the following two points when adjoining and wiring.

- ① The distance for which it concurrently wires is shortened as much as possible.
- ② The pattern interval is taken as widely as possible.

### 3. Parasitic capacitance change in electrode signal line

#### 3.1 Parasitic capacitance change that touch sensor receives

##### 3.1.1 Simulation condition

When there is an electrical change in the signal line near the electrode signal line  
 The parasitic capacitance change that the touch sensor detects is shown. (simulation result)

In the simulation, the electrode, the electrode line, and the LED drive line are arranged in P.C.B of 150mm\*80mm.  
 The change in the parasitic capacitance that the electrode line receives is analyzed as follows.

- ①For "Hi-z" the state of the LED drive line
- ②For "Low" the state of the LED drive line

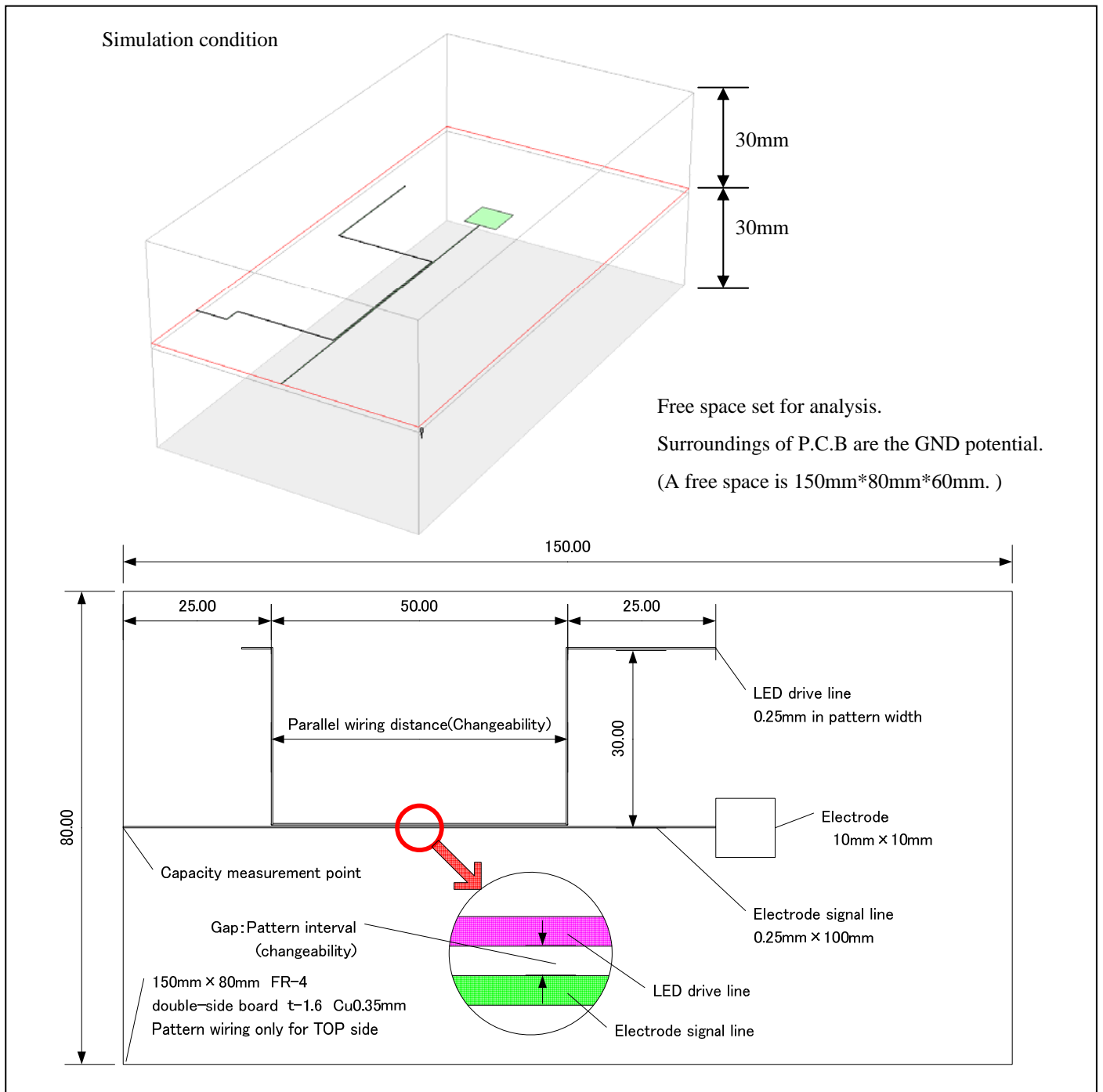

Figure 3-1 A parasitic capacitance increase by nearby wiring pattern (simulation condition)

3.1.2 Influence of nearby signal line

Figure 3-2 shows the change of the parasitic capacitance caused by the state of the signal line in the vicinity of the electrode signal line.

"Hi-z" and "Low" are in the state of the signal line. ("Low" : LED-ON. "Hi-z" : LED-OFF.)  
 The graph indicates the parasitic capacitance value of the electrode line.

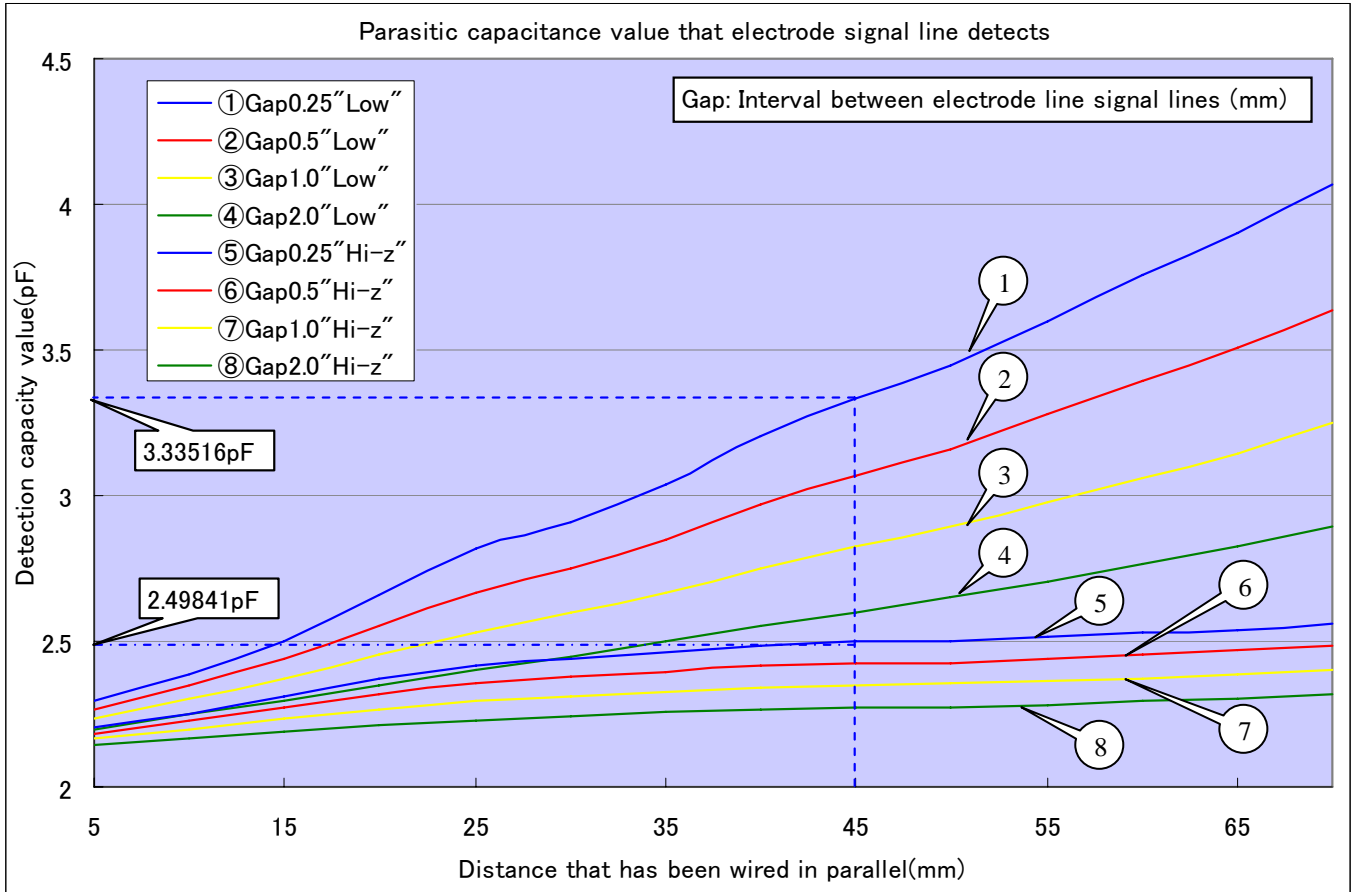

Figure 3-2 Difference of detection capacity value by state of signal line

Show in Figure 3-2.

The parasitic capacitance of the electrode line is in inverse proportion to the distance between patterns.  
 And, it grows in proportion to the length wired for in parallel.

Moreover, the parasitic capacitance value increases when the signal line is GND level.

Example

The nearby signal line : when Gap0.25mm and the distance wired for in parallel are 45mm.  
 The parasitic capacitance value that the electrode line measures

When the signal line is Hi-z 2.49841pF -----Graph data 5  
 When the signal line is Low 3.33516pF -----Graph data 1

### 3.1.3 Detection capacity value change ratio by level change in near signal line

The level change in a signal line near the touch electrode line influences the parasitic capacitance value that the touch electrode detects.

As an index that shows the influence

The change ratio of the parasitic capacitance value that the touch electrode detects is shown. (Figure 3-3)

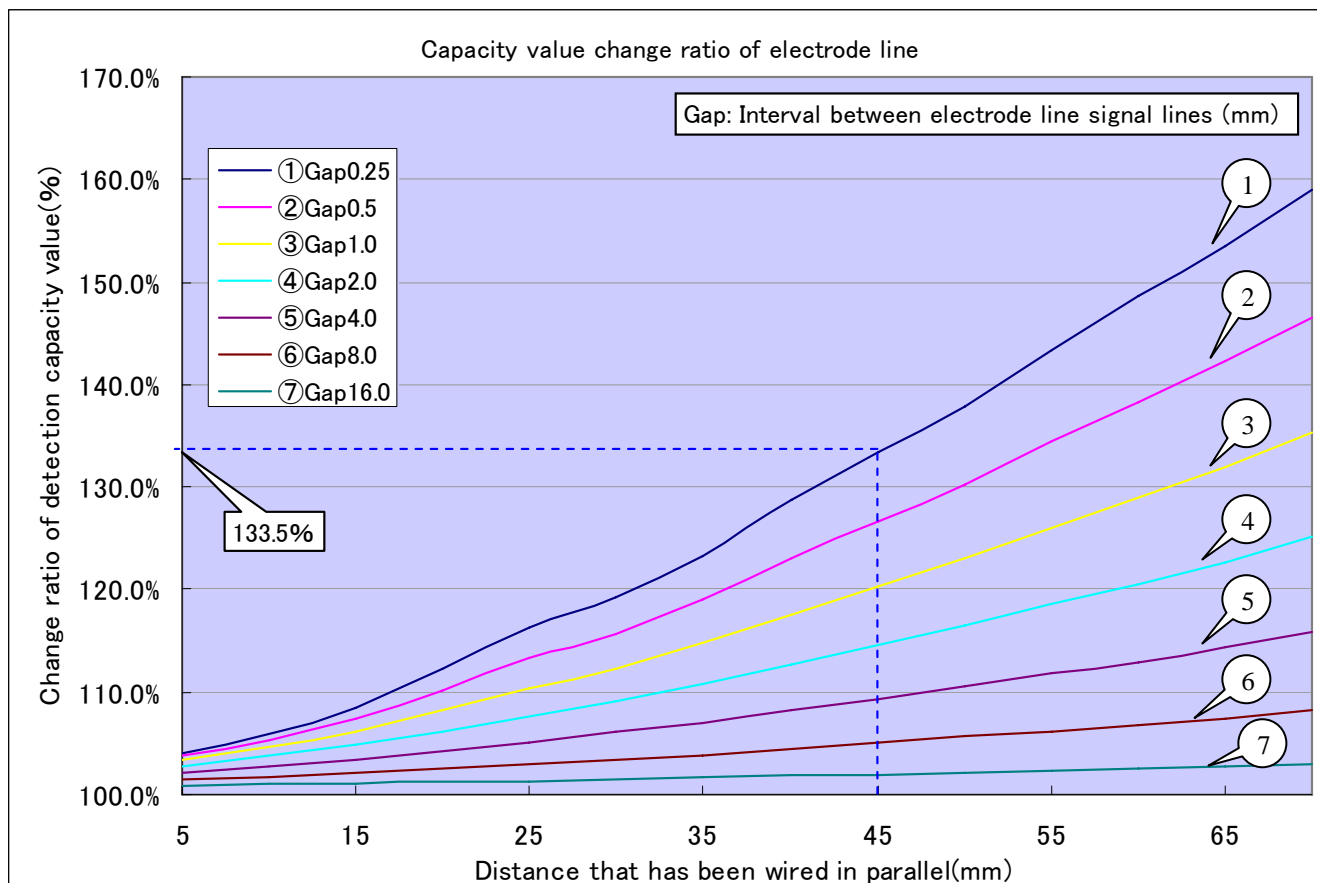

Figure 3-3 Detection capacity value change ratio by level change in near signal line

The parasitic capacitance that the touch electrode detects changes greatly by state (Hi-z/Low) of the nearby signal line as shown in Figure 3-3.

The change ratio of the detection capacity value when there is ON/OFF of LED while measuring the capacity of the touch electrode is calculated as follows.

Change ratio of parasitic capacitance value that touch electrode detects

$$= \text{Detection capacity value at LED-ON(Low)} / \text{Detection capacity value at LED-OFF(Hi-z)} * 100 (\%)$$

Example

The nearby signal line : when Gap0.25mm and the distance wired for in parallel are 45mm.

The change ratio of the detection volume by LED-ON

$$= 3.33516\text{pF} / 2.49841\text{pF} * 100(\%)$$

$$= 133.5\%$$

The detected capacity value will increase by driving LED by about 33.5%  
(increasing rate about 33.5% of detection volume by LED-ON)

An increase in the detection volume becomes the variation factor of the measurement value (noise).

There is a possibility of becoming the factor of the malfunction according to the state of the system.

(State of system : Amount of change at time usually.

Change ratio of detection capacity value by electrical change of nearby line.

Condition of ON/OFF threshold etc. )

## 4. Development case

### 4.1 Development case in demonstration P.C.B

Figure 4-1 shows the development case in demonstration P.C.B.

In this demonstration P.C.B, the influence by LED of the PWM control arranged in the vicinity of the electrode is decreased by devising the arrangement of the LED drive line.

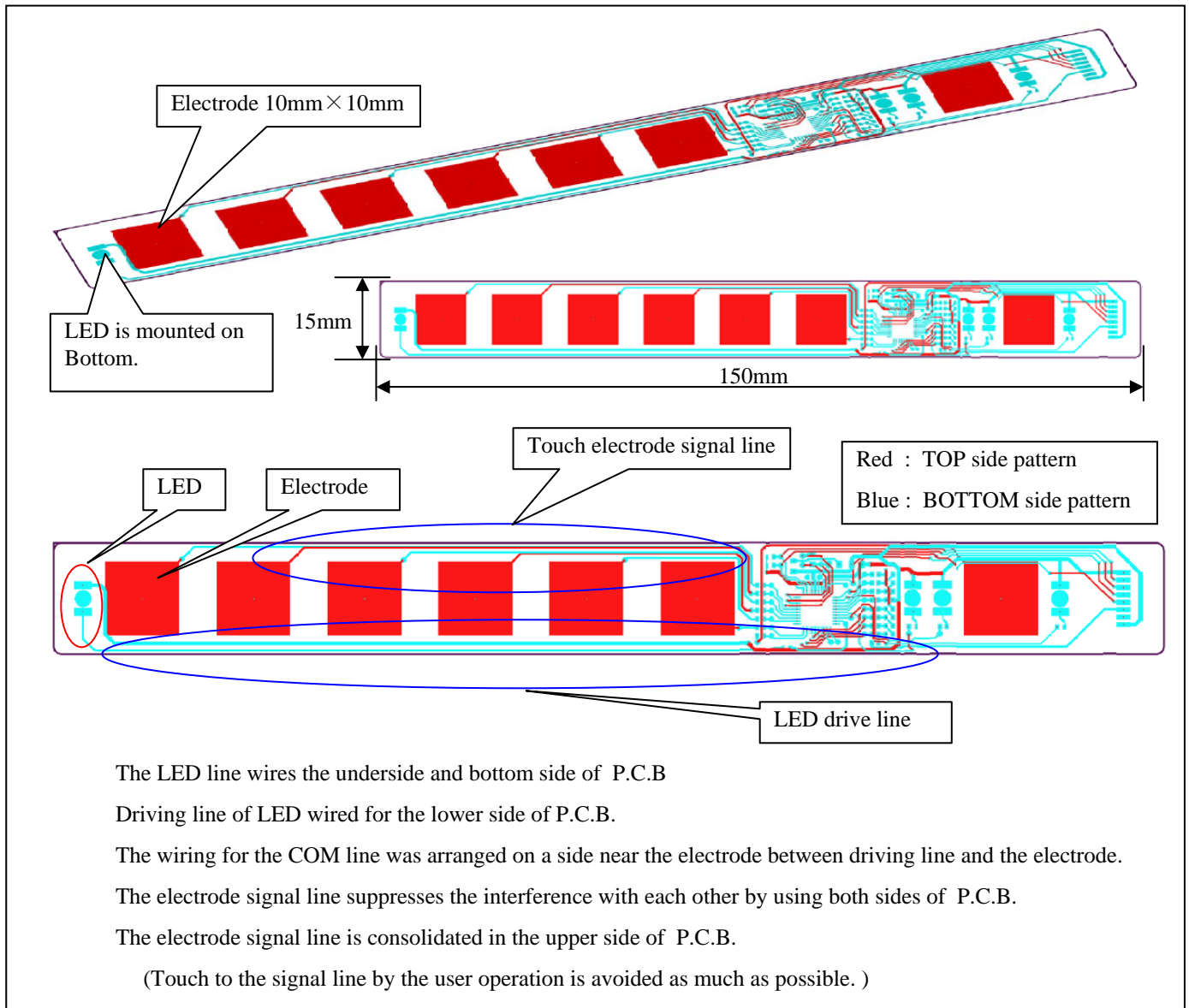

Figure 4-1 Example of wiring for touch board equipped with PWM drive LED

### 4.2 Example of arranging LED around touch electrode

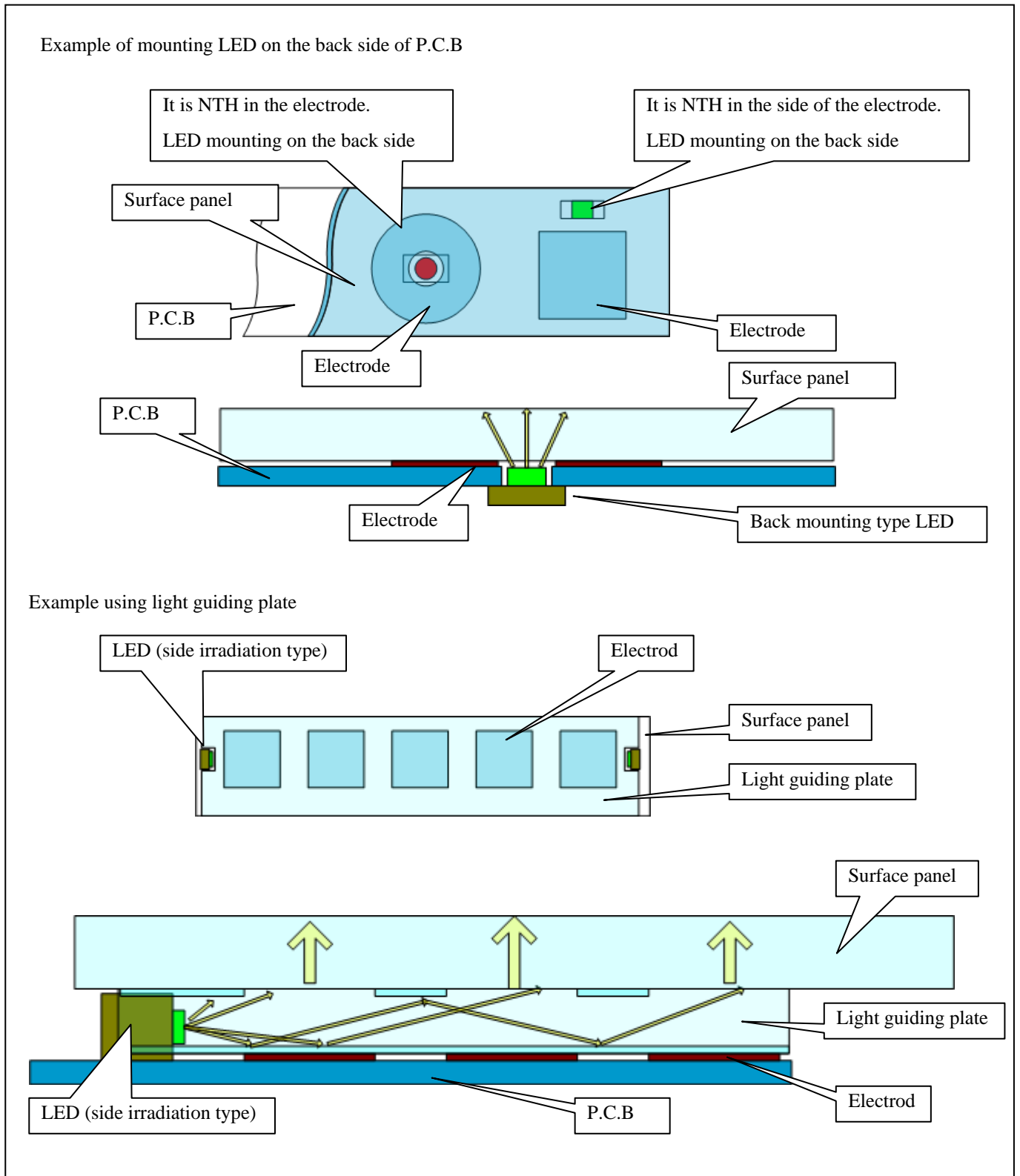

Figure 4-2 Example of arranging LED around touch electrode

### Website and Support

Renesas Electronics Website

<http://www.renesas.com/>

Inquiries

<http://www.renesas.com/inquiry>

### Revision Record

Rev.	Date	Description	
		Page	Summary
1.00	Jan.31.11	—	First edition issued

All trademarks and registered trademarks are the property of their respective owners.

## General Precautions in the Handling of MPU/MCU Products

The following usage notes are applicable to all MPU/MCU products from Renesas. For detailed usage notes on the products covered by this manual, refer to the relevant sections of the manual. If the descriptions under General Precautions in the Handling of MPU/MCU Products and in the body of the manual differ from each other, the description in the body of the manual takes precedence.

### 1. Handling of Unused Pins

Handle unused pins in accord with the directions given under Handling of Unused Pins in the manual.

- The input pins of CMOS products are generally in the high-impedance state. In operation with an unused pin in the open-circuit state, extra electromagnetic noise is induced in the vicinity of LSI, an associated shoot-through current flows internally, and malfunctions occur due to the false recognition of the pin state as an input signal become possible. Unused pins should be handled as described under Handling of Unused Pins in the manual.

### 2. Processing at Power-on

The state of the product is undefined at the moment when power is supplied.

- The states of internal circuits in the LSI are indeterminate and the states of register settings and pins are undefined at the moment when power is supplied.

In a finished product where the reset signal is applied to the external reset pin, the states of pins are not guaranteed from the moment when power is supplied until the reset process is completed.

In a similar way, the states of pins in a product that is reset by an on-chip power-on reset function are not guaranteed from the moment when power is supplied until the power reaches the level at which resetting has been specified.

### 3. Prohibition of Access to Reserved Addresses

Access to reserved addresses is prohibited.

- The reserved addresses are provided for the possible future expansion of functions. Do not access these addresses; the correct operation of LSI is not guaranteed if they are accessed.

### 4. Clock Signals

After applying a reset, only release the reset line after the operating clock signal has become stable.

When switching the clock signal during program execution, wait until the target clock signal has stabilized.

- When the clock signal is generated with an external resonator (or from an external oscillator) during a reset, ensure that the reset line is only released after full stabilization of the clock signal. Moreover, when switching to a clock signal produced with an external resonator (or by an external oscillator) while program execution is in progress, wait until the target clock signal is stable.

### 5. Differences between Products

Before changing from one product to another, i.e. to one with a different type number, confirm that the change will not lead to problems.

- The characteristics of MPU/MCU in the same group but having different type numbers may differ because of the differences in internal memory capacity and layout pattern. When changing to products of different type numbers, implement a system-evaluation test for each of the products.

## Notice

- All information included in this document is current as of the date this document is issued. Such information, however, is subject to change without any prior notice. Before purchasing or using any Renesas Electronics products listed herein, please confirm the latest product information with a Renesas Electronics sales office. Also, please pay regular and careful attention to additional and different information to be disclosed by Renesas Electronics such as that disclosed through our website.
- Renesas Electronics does not assume any liability for infringement of patents, copyrights, or other intellectual property rights of third parties by or arising from the use of Renesas Electronics products or technical information described in this document. No license, express, implied or otherwise, is granted hereby under any patents, copyrights or other intellectual property rights of Renesas Electronics or others.
- You should not alter, modify, copy, or otherwise misappropriate any Renesas Electronics product, whether in whole or in part.
- Descriptions of circuits, software and other related information in this document are provided only to illustrate the operation of semiconductor products and application examples. You are fully responsible for the incorporation of these circuits, software, and information in the design of your equipment. Renesas Electronics assumes no responsibility for any losses incurred by you or third parties arising from the use of these circuits, software, or information.
- When exporting the products or technology described in this document, you should comply with the applicable export control laws and regulations and follow the procedures required by such laws and regulations. You should not use Renesas Electronics products or the technology described in this document for any purpose relating to military applications or use by the military, including but not limited to the development of weapons of mass destruction. Renesas Electronics products and technology may not be used for or incorporated into any products or systems whose manufacture, use, or sale is prohibited under any applicable domestic or foreign laws or regulations.
- Renesas Electronics has used reasonable care in preparing the information included in this document, but Renesas Electronics does not warrant that such information is error free. Renesas Electronics assumes no liability whatsoever for any damages incurred by you resulting from errors in or omissions from the information included herein.
- Renesas Electronics products are classified according to the following three quality grades: "Standard", "High Quality", and "Specific". The recommended applications for each Renesas Electronics product depends on the product's quality grade, as indicated below. You must check the quality grade of each Renesas Electronics product before using it in a particular application. You may not use any Renesas Electronics product for any application categorized as "Specific" without the prior written consent of Renesas Electronics. Further, you may not use any Renesas Electronics product for any application for which it is not intended without the prior written consent of Renesas Electronics. Renesas Electronics shall not be in any way liable for any damages or losses incurred by you or third parties arising from the use of any Renesas Electronics product for an application categorized as "Specific" or for which the product is not intended where you have failed to obtain the prior written consent of Renesas Electronics. The quality grade of each Renesas Electronics product is "Standard" unless otherwise expressly specified in a Renesas Electronics data sheets or data books, etc.  
"Standard": Computers; office equipment; communications equipment; test and measurement equipment; audio and visual equipment; home electronic appliances; machine tools; personal electronic equipment; and industrial robots.  
"High Quality": Transportation equipment (automobiles, trains, ships, etc.); traffic control systems; anti-disaster systems; anti-crime systems; safety equipment; and medical equipment not specifically designed for life support.  
"Specific": Aircraft; aerospace equipment; submersible repeaters; nuclear reactor control systems; medical equipment or systems for life support (e.g. artificial life support devices or systems), surgical implantations, or healthcare intervention (e.g. excision, etc.), and any other applications or purposes that pose a direct threat to human life.
- You should use the Renesas Electronics products described in this document within the range specified by Renesas Electronics, especially with respect to the maximum rating, operating supply voltage range, movement power voltage range, heat radiation characteristics, installation and other product characteristics. Renesas Electronics shall have no liability for malfunctions or damages arising out of the use of Renesas Electronics products beyond such specified ranges.
- Although Renesas Electronics endeavors to improve the quality and reliability of its products, semiconductor products have specific characteristics such as the occurrence of failure at a certain rate and malfunctions under certain use conditions. Further, Renesas Electronics products are not subject to radiation resistance design. Please be sure to implement safety measures to guard them against the possibility of physical injury, and injury or damage caused by fire in the event of the failure of a Renesas Electronics product, such as safety design for hardware and software including but not limited to redundancy, fire control and malfunction prevention, appropriate treatment for aging degradation or any other appropriate measures. Because the evaluation of microcomputer software alone is very difficult, please evaluate the safety of the final products or system manufactured by you.
- Please contact a Renesas Electronics sales office for details as to environmental matters such as the environmental compatibility of each Renesas Electronics product. Please use Renesas Electronics products in compliance with all applicable laws and regulations that regulate the inclusion or use of controlled substances, including without limitation, the EU RoHS Directive. Renesas Electronics assumes no liability for damages or losses occurring as a result of your noncompliance with applicable laws and regulations.
- This document may not be reproduced or duplicated, in any form, in whole or in part, without prior written consent of Renesas Electronics.
- Please contact a Renesas Electronics sales office if you have any questions regarding the information contained in this document or Renesas Electronics products, or if you have any other inquiries.  
(Note 1) "Renesas Electronics" as used in this document means Renesas Electronics Corporation and also includes its majority-owned subsidiaries.  
(Note 2) "Renesas Electronics product(s)" means any product developed or manufactured by or for Renesas Electronics.



### SALES OFFICES

Renesas Electronics Corporation

<http://www.renesas.com>

Refer to "<http://www.renesas.com/>" for the latest and detailed information.

#### Renesas Electronics America Inc.

2880 Scott Boulevard Santa Clara, CA 95050-2554, U.S.A.  
Tel: +1-408-588-6000, Fax: +1-408-588-6130

#### Renesas Electronics Canada Limited

1101 Nicholson Road, Newmarket, Ontario L3Y 9C3, Canada  
Tel: +1-905-898-5441, Fax: +1-905-898-3220

#### Renesas Electronics Europe Limited

Dukes Meadow, Millboard Road, Bourne End, Buckinghamshire, SL8 5FH, U.K.  
Tel: +44-1628-585-100, Fax: +44-1628-585-900

#### Renesas Electronics Europe GmbH

Arcadiastrasse 10, 40472 Düsseldorf, Germany  
Tel: +49-211-6503-0, Fax: +49-211-6503-1327

#### Renesas Electronics (China) Co., Ltd.

7th Floor, Quantum Plaza, No.27 ZhiChunLu Haidian District, Beijing 100083, P.R.China  
Tel: +86-10-8235-1155, Fax: +86-10-8235-7679

#### Renesas Electronics (Shanghai) Co., Ltd.

Unit 204, 205, AZIA Center, No.1233 Lujiazui Ring Rd., Pudong District, Shanghai 200120, China  
Tel: +86-21-5877-1818, Fax: +86-21-6887-7858 / -7898

#### Renesas Electronics Hong Kong Limited

Unit 1601-1613, 16/F., Tower 2, Grand Century Place, 193 Prince Edward Road West, Mongkok, Kowloon, Hong Kong  
Tel: +852-2886-9318, Fax: +852-2886-9022/9044

#### Renesas Electronics Taiwan Co., Ltd.

7F, No. 363 Fu Shing North Road Taipei, Taiwan, R.O.C.  
Tel: +886-2-8175-9600, Fax: +886-2-8175-9670

#### Renesas Electronics Singapore Pte. Ltd.

1 HarbourFront Avenue, #06-10, Keppel Bay Tower, Singapore 098632  
Tel: +65-6213-0200, Fax: +65-6278-8001

#### Renesas Electronics Malaysia Sdn.Bhd.

Unit 906, Block B, Menara Amcorp, Amcorp Trade Centre, No. 18, Jln Persiaran Barat, 46050 Petaling Jaya, Selangor Darul Ehsan, Malaysia  
Tel: +60-3-7955-9390, Fax: +60-3-7955-9510

#### Renesas Electronics Korea Co., Ltd.

11F., Samik Lavied' or Bldg., 720-2 Yeoksam-Dong, Kangnam-Ku, Seoul 135-080, Korea  
Tel: +82-2-558-3737, Fax: +82-2-558-5141