

To our customers,

Old Company Name in Catalogs and Other Documents

On April 1st, 2010, NEC Electronics Corporation merged with Renesas Technology Corporation, and Renesas Electronics Corporation took over all the business of both companies. Therefore, although the old company name remains in this document, it is a valid Renesas Electronics document. We appreciate your understanding.

Renesas Electronics website: <http://www.renesas.com>

April 1st, 2010
Renesas Electronics Corporation

Issued by: Renesas Electronics Corporation (<http://www.renesas.com>)

Send any inquiries to <http://www.renesas.com/inquiry>.

Notice

1. All information included in this document is current as of the date this document is issued. Such information, however, is subject to change without any prior notice. Before purchasing or using any Renesas Electronics products listed herein, please confirm the latest product information with a Renesas Electronics sales office. Also, please pay regular and careful attention to additional and different information to be disclosed by Renesas Electronics such as that disclosed through our website.
2. Renesas Electronics does not assume any liability for infringement of patents, copyrights, or other intellectual property rights of third parties by or arising from the use of Renesas Electronics products or technical information described in this document. No license, express, implied or otherwise, is granted hereby under any patents, copyrights or other intellectual property rights of Renesas Electronics or others.
3. You should not alter, modify, copy, or otherwise misappropriate any Renesas Electronics product, whether in whole or in part.
4. Descriptions of circuits, software and other related information in this document are provided only to illustrate the operation of semiconductor products and application examples. You are fully responsible for the incorporation of these circuits, software, and information in the design of your equipment. Renesas Electronics assumes no responsibility for any losses incurred by you or third parties arising from the use of these circuits, software, or information.
5. When exporting the products or technology described in this document, you should comply with the applicable export control laws and regulations and follow the procedures required by such laws and regulations. You should not use Renesas Electronics products or the technology described in this document for any purpose relating to military applications or use by the military, including but not limited to the development of weapons of mass destruction. Renesas Electronics products and technology may not be used for or incorporated into any products or systems whose manufacture, use, or sale is prohibited under any applicable domestic or foreign laws or regulations.
6. Renesas Electronics has used reasonable care in preparing the information included in this document, but Renesas Electronics does not warrant that such information is error free. Renesas Electronics assumes no liability whatsoever for any damages incurred by you resulting from errors in or omissions from the information included herein.
7. Renesas Electronics products are classified according to the following three quality grades: “Standard”, “High Quality”, and “Specific”. The recommended applications for each Renesas Electronics product depends on the product’s quality grade, as indicated below. You must check the quality grade of each Renesas Electronics product before using it in a particular application. You may not use any Renesas Electronics product for any application categorized as “Specific” without the prior written consent of Renesas Electronics. Further, you may not use any Renesas Electronics product for any application for which it is not intended without the prior written consent of Renesas Electronics. Renesas Electronics shall not be in any way liable for any damages or losses incurred by you or third parties arising from the use of any Renesas Electronics product for an application categorized as “Specific” or for which the product is not intended where you have failed to obtain the prior written consent of Renesas Electronics. The quality grade of each Renesas Electronics product is “Standard” unless otherwise expressly specified in a Renesas Electronics data sheets or data books, etc.
 - “Standard”: Computers; office equipment; communications equipment; test and measurement equipment; audio and visual equipment; home electronic appliances; machine tools; personal electronic equipment; and industrial robots.
 - “High Quality”: Transportation equipment (automobiles, trains, ships, etc.); traffic control systems; anti-disaster systems; anti-crime systems; safety equipment; and medical equipment not specifically designed for life support.
 - “Specific”: Aircraft; aerospace equipment; submersible repeaters; nuclear reactor control systems; medical equipment or systems for life support (e.g. artificial life support devices or systems), surgical implantations, or healthcare intervention (e.g. excision, etc.), and any other applications or purposes that pose a direct threat to human life.
8. You should use the Renesas Electronics products described in this document within the range specified by Renesas Electronics, especially with respect to the maximum rating, operating supply voltage range, movement power voltage range, heat radiation characteristics, installation and other product characteristics. Renesas Electronics shall have no liability for malfunctions or damages arising out of the use of Renesas Electronics products beyond such specified ranges.
9. Although Renesas Electronics endeavors to improve the quality and reliability of its products, semiconductor products have specific characteristics such as the occurrence of failure at a certain rate and malfunctions under certain use conditions. Further, Renesas Electronics products are not subject to radiation resistance design. Please be sure to implement safety measures to guard them against the possibility of physical injury, and injury or damage caused by fire in the event of the failure of a Renesas Electronics product, such as safety design for hardware and software including but not limited to redundancy, fire control and malfunction prevention, appropriate treatment for aging degradation or any other appropriate measures. Because the evaluation of microcomputer software alone is very difficult, please evaluate the safety of the final products or system manufactured by you.
10. Please contact a Renesas Electronics sales office for details as to environmental matters such as the environmental compatibility of each Renesas Electronics product. Please use Renesas Electronics products in compliance with all applicable laws and regulations that regulate the inclusion or use of controlled substances, including without limitation, the EU RoHS Directive. Renesas Electronics assumes no liability for damages or losses occurring as a result of your noncompliance with applicable laws and regulations.
11. This document may not be reproduced or duplicated, in any form, in whole or in part, without prior written consent of Renesas Electronics.
12. Please contact a Renesas Electronics sales office if you have any questions regarding the information contained in this document or Renesas Electronics products, or if you have any other inquiries.

(Note 1) “Renesas Electronics” as used in this document means Renesas Electronics Corporation and also includes its majority-owned subsidiaries.

(Note 2) “Renesas Electronics product(s)” means any product developed or manufactured by or for Renesas Electronics.

M16C/6N, M16C/1N, M16C/29, R8C/22,23 Groups

CAN Application Note

1. Summary

This document describes the procedure to be followed when performing CAN communication using the M16C/6N, M16C/1N, M16C/29, or R8C/22,23 group of microcomputers.

2. Application

This document applies to the M16C/6N, M16C/1N, M16C/29, or R8C/22,23 group of microcomputers (hereafter referred to respectively as 6N, 1N, 29, or R8C/22,23).

The 6N group is further divided into six subgroups: 6N4, 6N5, 6NK, 6NL, 6NM, and 6NN. The 6N5, 6NL, 6NN, 1N, 29, and R8C/22,23 have only CAN0, so that the descriptions relating to CAN1 do not apply to these groups.

1. Summary	1
2. Application	1
3. Initial Settings	2
3.1 CAN Bit Timing	3
3.1.1 Bit Timing Conditions	4
3.2 How to Synchronize Bits	5
3.3 Baud Rate	7
3.4 Setting CAN Bit Timing and Baud rate	9
4. Transmitting/Receiving CAN Messages	10
4.1 CAN Configuration	11
4.2 Message Transmission.....	12
4.2.1 Data Frame Transmit Mode	13
4.2.2 Remote Frame Receive/Data Frame Transmit Mode	17
4.2.3 Abort Transmission	20
4.3 Receiving Messages	25
4.3.1 Data Frame Receive Mode	26
4.3.2 Remote Frame Transmit/Data Frame Receive Mode	32
4.4 CAN Overrun Error.....	33
4.5 Basic CAN Mode	34
5. CAN Errors	36
5.1 CAN Error Confirmation Procedure.....	37
5.2 Return from Bus-off Function	39
6. Using the Acceptance Filter	40
6.1 Acceptance Filter (ACP).....	40
6.2 Acceptance Filter Support Unit (ASU).....	43
6.2.1 Using the Acceptance Filter Support Unit.....	43
7. CAN Sleep and CAN Wakeup Operations	47
7.1 CAN Sleep Operation.....	47
7.2 CAN Wakeup Operation.....	48
8. Precautions Regarding the Sample Program	49
8.1 Symbol Notation of Each Register	49
8.2 while Infinite Loop.....	49
9. Web Site and Support Center	50

3. Initial Settings

Before CAN communication can be performed, following settings must be made:

- CAN operation mode setting
- Baud rate setting
- Sampling count setting (Sampling counts are set to 1)
- Bit timing setting
- Acceptance filter setting

Furthermore, following programs must be created according to the system used:

- Program for finishing transmission by a CAN transmit-completed interrupt
- Program for finishing transmission by polling
- Program for finishing reception by a CAN receive-completed interrupt
- Program for finishing reception by polling
- Program for handling a CAN error interrupt
- Program for handling a CAN wakeup interrupt

3.1 CAN Bit Timing

In the CAN protocol, each bit in a communication frame is composed with four segments.

Figure 1 shows the segment composition of a bit and the sampling point in it.

Of these segments, the Propagation Time Segment (hereafter PTS), Phase Buffer Segment 1 (hereafter PBS1), and Phase Buffer Segment 2 (hereafter PBS2) are used to specify a sampling point, so that the timing with which each bit is sampled can be altered by changing the values of these segments.

The minimum unit in which this timing is set is referred to as Time Quantum (hereafter Tq), which is determined by the clock frequency supplied to the CAN module and the divide-by-N value of the baud rate prescaler.

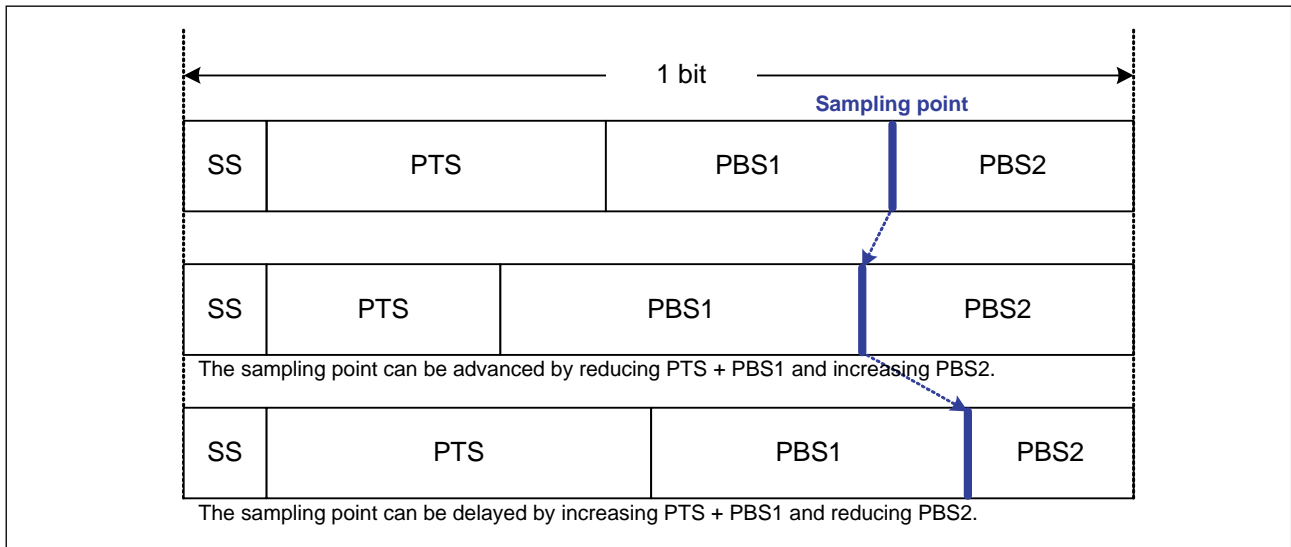

Figure 1 Segment composition of a bit and the sampling point

(1) SS: Synchronization Segment

This segment is used to synchronize bits by monitoring a recessive-to-dominant edge during the Interframe Space*1.

(2) PTS: Propagation Time Segment

This segment absorbs physical delays on the CAN network. A physical delay on the network is two times the sum total of a bus delay, input comparator delay, and output driver delay.

(3) PBS1, PBS2: Phase Buffer Segment 1, Phase Buffer Segment 2

These segments are used to correct a phase error*2 that occurs when bits are resynchronized.

(4) SJW: Resynchronization Jump Width

This is the maximum width by which bits gotten out of sync due to a phase error are corrected.

*1: Interframe Space

Comprised of Intermission, Suspend Transmission, and Bus Idle. During bus idle, all nodes can start transmission.

*2: Phase Error

Refers to out-of-sync caused by a drift in the oscillator frequency, etc. For details, refer to paragraph (2) in Section 3.2.

3.1.1 Bit Timing Conditions

The following describes how each segment is set and the limitations that apply to the segment setting.

(1) Each segment setting

- SS = Fixed to 1 Tq
- PTS = Set in the range 1 to 8 Tq's.
- PBS1 = Set in the range 2 to 8 Tq's.
- PBS2 = Set in the range 2 to 8 Tq's.
- SJW = Set in the range 1 to 4 Tq's.
- SS + PTS + PBS1 + PBS2 = 8 to 25 Tq's

(2) Limitations on PBS1 and PBS2

- $PBS1 \geq PBS2$
- $PBS1 \geq SJW$
- $PBS2 \geq 2$ when $SJW = 1$
- $PBS2 \geq SJW$ when $2 \leq SJW \leq 4$

3.2 How to Synchronize Bits

The communication method of CAN protocol is Non-Return to Zero (NRZ). No synchronizing signals are added to the beginning or end of each bit.

(1) Hardware synchronization (synchronization achieved when not sending or receiving messages)

When a recessive-to-dominant edge is detected in the interframe space, that point of time is recognized as the beginning of a bit (SS), based on which bits are synchronized. This is referred to as hardware synchronization.

Figure 2 shows the mechanism of hardware synchronization.

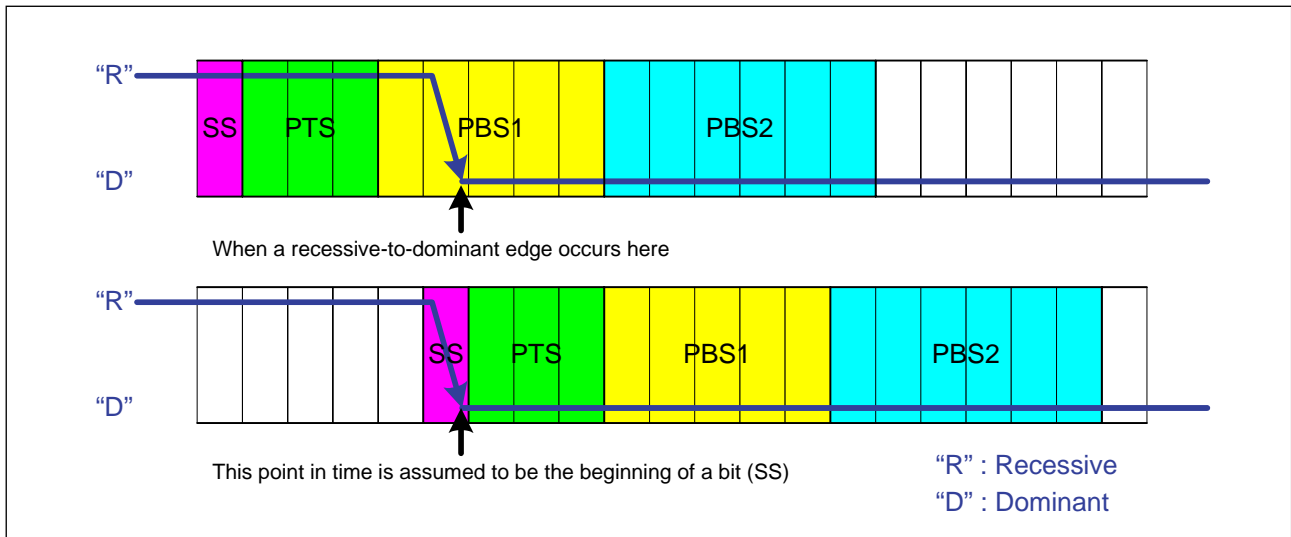

Figure 2 Mechanism of hardware synchronization

(2) Resynchronization (synchronization achieved when sending or receiving messages)

While sending or receiving a message, communication frames between some nodes may get out of sync due to a drift in the oscillator frequency or a delay in the transmission path. This is referred to as a phase error. If a bit gets out of sync, the length of the bit is dynamically corrected by adding the SJW value (or the SJW value if gotten out of sync more than the SJW value) to PBS1 or subtracting from PBS2. This is referred to as resynchronization.

Resynchronization is achieved by synchronizing bits with respect to only recessive-to-dominant edges as in the case of hardware synchronization.

Figure 3 and Figure 4 show the mechanism of resynchronization.

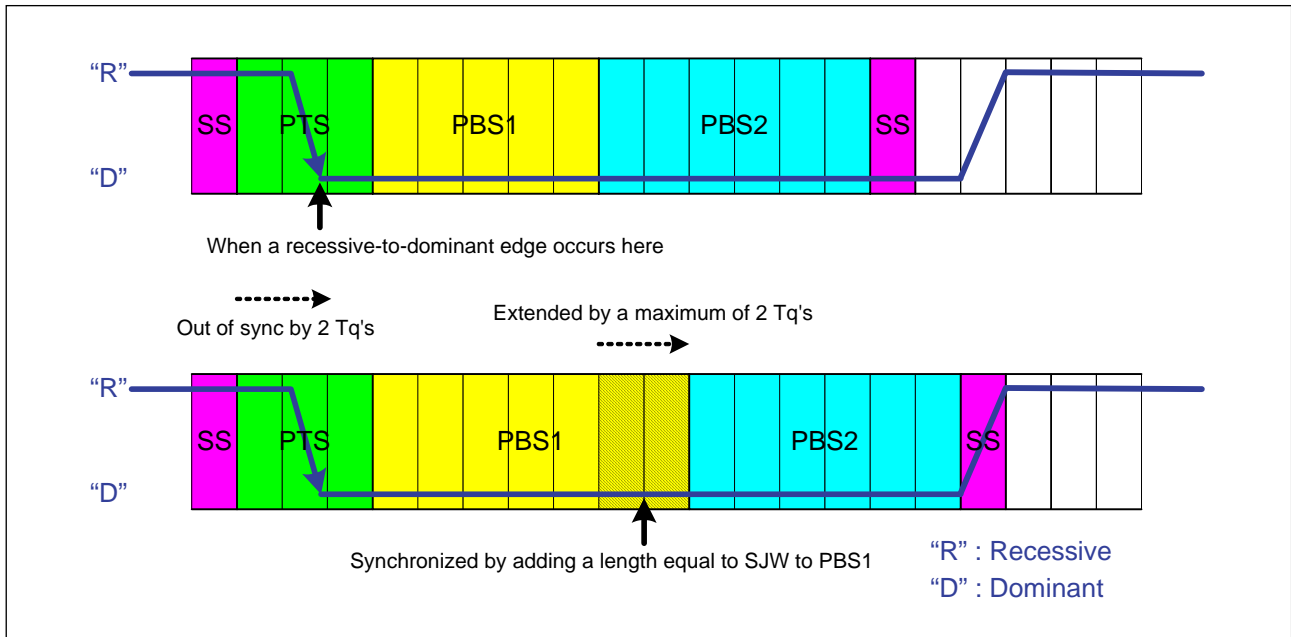

Figure 3 Resynchronization mechanism: when the R → D edge occurs in either the PTS or the PBS1 period (example for SJW = 2)

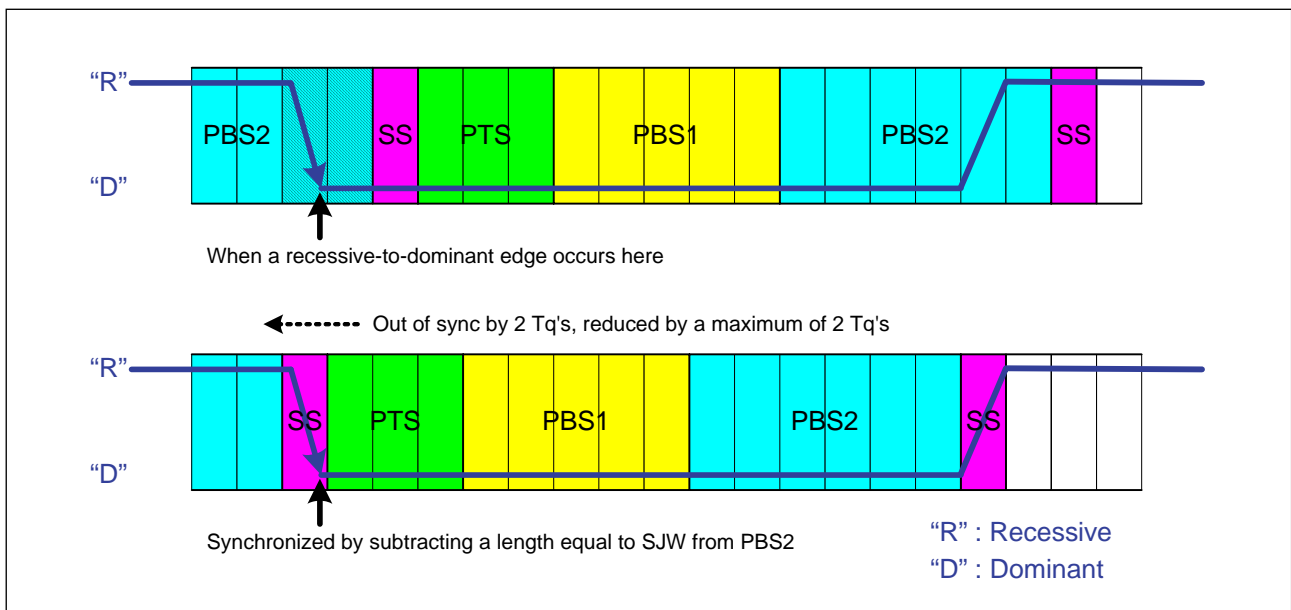

Figure 4 Resynchronization mechanism: when the R → D edge occurs in the PBS2 period (example for SJW = 2)

3.3 Baud Rate

The transfer speed is determined by f_1 , the divide-by-N value of the CAN module system clock, the divide-by-N value of the baud rate prescaler, and the number of T_q 's in one bit.

Figure 5 shows a block diagram of the circuit that generates the CAN module system clock.

Table 1 shows a baud rate calculation formula and an example implementation. Table 2 shows an example of how to set the bit timing.

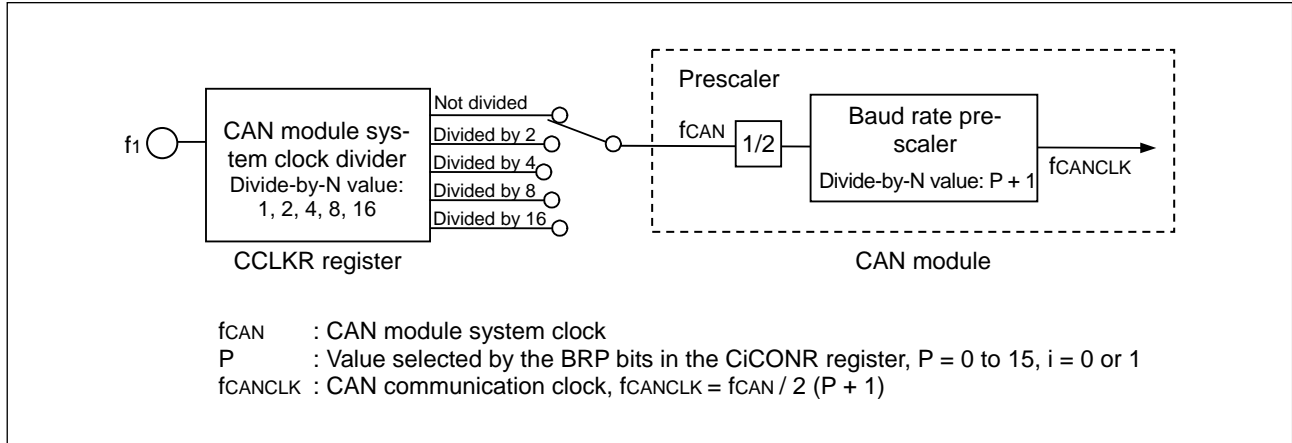

Figure 5 Block diagram of the circuit that generates the CAN module system clock

Table 1 Baud rate calculation formula and example implementation

Baud rate calculation formula	f_1				
	$2 \times f_{CAN} \text{ divide-by-N value}^{*1} \times \text{baud rate prescaler divide-by-N value}^{*2} \times \text{number of } T_q\text{'s in one bit}$				
Baud rate	24MHz ^{*3}	20MHz ^{*4}	16MHz	10MHz	8MHz
1Mbps	12Tq (1)	10Tq (1)	8Tq (1)	-	-
500kbps	12Tq (2) 24Tq (1)	10Tq (2) 20Tq (1)	8Tq (2) 16Tq (1)	10Tq (1) -	8Tq (1) -
125kbps	12Tq (8) 16Tq (6) 24Tq (4)	10Tq (8) 20Tq (4) -	8Tq (8) 16Tq (4) -	10Tq (4) 20Tq (2) -	8Tq (4) 16Tq (2) -
83.3kbps	12Tq (12) 16Tq (9) 24Tq (6)	10Tq (12) 20Tq (6) -	8Tq (12) 16Tq (6) -	10Tq (6) 20Tq (3) -	8Tq (6) 16Tq (3) -
33.3kbps	10Tq (30) 20Tq (15)	10Tq (30) 20Tq (15)	8Tq (30) 16Tq (15)	10Tq (15) -	8Tq (15) -

*1: f_{CAN} divide-by-N value = 1, 2, 4, 8, 16

f_{CAN} divide-by-N value: one that is selected by the CCLKR register.

*2: Baud rate prescaler divide-by-N value = $P + 1$ ($P = 0-15$)

P : value selected by the BRP bits in the CiCONR register ($i = 0$ or 1).

*3: The 6NK, 6NL, 6NM, and 6NN groups apply

*4: The 1N group does not apply.

*5: Shown in () are the f_{CAN} divide-by-N value X baud rate prescaler divide-by-N value

Table 2 Example settings of bit timing

1 bit	Set value (Tq)					Sample point ^{*1} (%)
	SS	PTS	PBS1	PBS2	SJW	
8Tq	1	1	3	3	1	62.50
	1	3	2	2	1	75.00
10Tq	1	3	3	3	1	70.00
	1	5	2	2	1	80.00
16Tq	1	5	5	5	1	68.75
	1	7	4	4	1	75.00
20Tq	1	7	6	6	1	70.00
	1	5	7	7	1	65.00

*1: Sampling point (for the case where sampling point=75%)

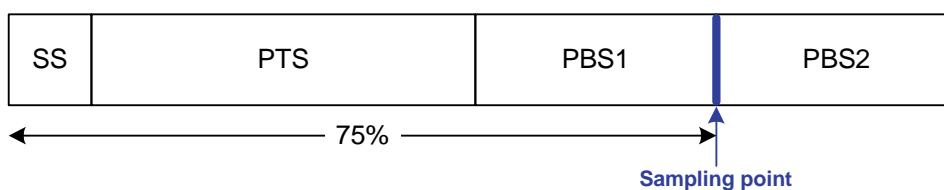

3.4 Setting CAN Bit Timing and Baud rate

Figure 6 shows the procedure for setting the CAN bit timing and the baud rate. These settings must always be performed during CAN configuration. For details about the CAN configuration procedure, refer to Section 4.1.

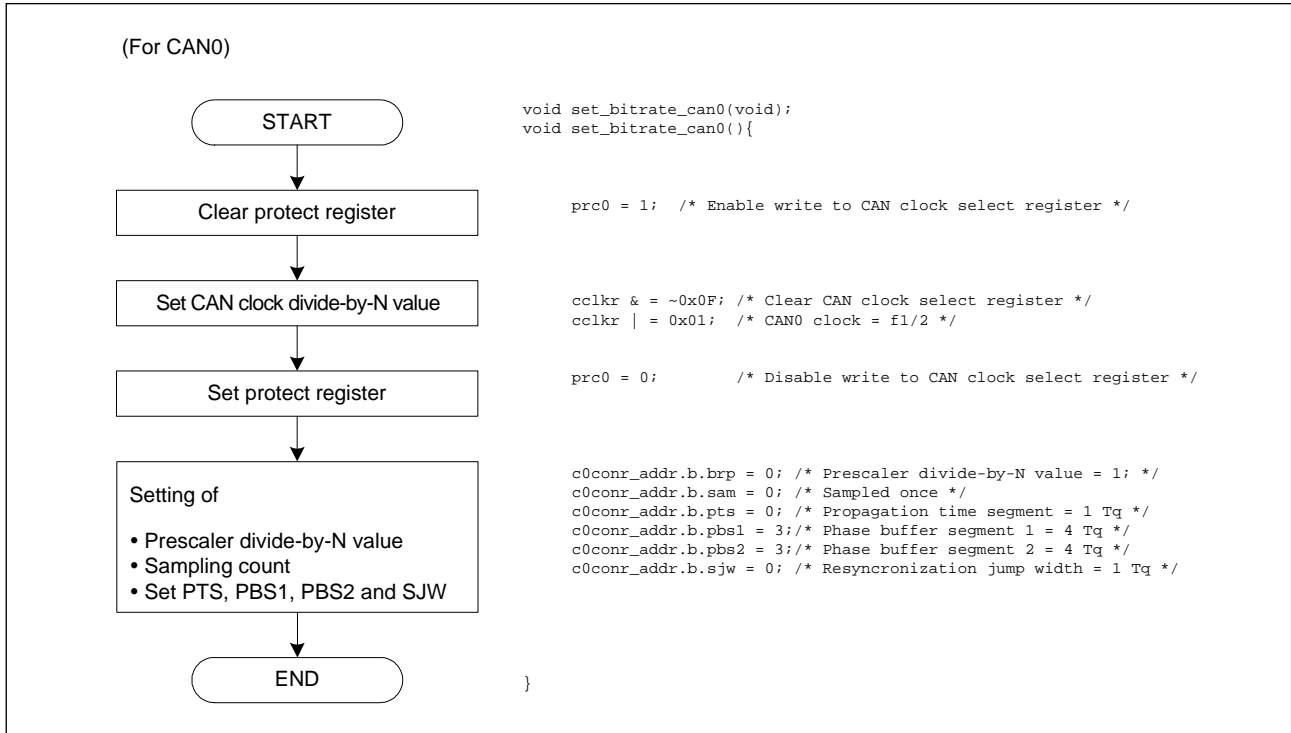

Figure 6 Procedure for setting the CAN bit timing and the baud rate

4. Transmitting/Receiving CAN Messages

CAN messages are transmitted / received following the three procedures described below.

(1) CAN configuration procedure

Set each relevant register during reset/initialization mode*¹. These include the CAN control register, CAN bus timing control register, CAN clock select register, and mask register.

*1: The CAN message control register, CAN interrupt control register, and CAN extended ID register are automatically cleared when the CAN module goes from operating mode to reset/initialization mode. Note that these registers cannot be set during reset/initialization mode. Restore the CAN module to operating mode before setting these registers.

(2) Slot configuration procedure

To place any slot in transmit or receive mode, use the CAN message control register that is provided for each slot.

Table 3 shows the relationship between settings of the CAN message control register and the slot operation in transmit/receive modes.

(3) Data processing procedure

Perform message processing when the CAN module has finished sending or receiving a message normally.

Table 3 Relationship between CAN message control register settings and transmit/receive modes

C0MCTL/C1MCTL				Slot operation in transmit/receive modes
bit7 TrmReq	bit6 RecReq	bit5 Remote	bit4 RspLock	
0	0	-	-	Do not send or receive frames.
0	1	0	0	Receive a data frame (data frame receive mode)
1	0	1	0	Send a remote frame and when finished sending, receive a data frame. (Remote frame transmit/data frame receive mode)
1	0	0	0	Send a data frame (data frame transmit mode)
0	1	1	1/0 ^{*1}	Receive a remote frame and when finished receiving, send a data frame. (Remote frame receive/data frame transmit mode) ^{*1} RspLock: 0: Send a data frame after receiving a remote frame as an automatic response. 1: Stand by without sending a data frame after receiving a remote frame. Clearing this bit causes the slot to send a data frame.

4.1 CAN Configuration

Figure 7 shows the CAN configuration procedure.

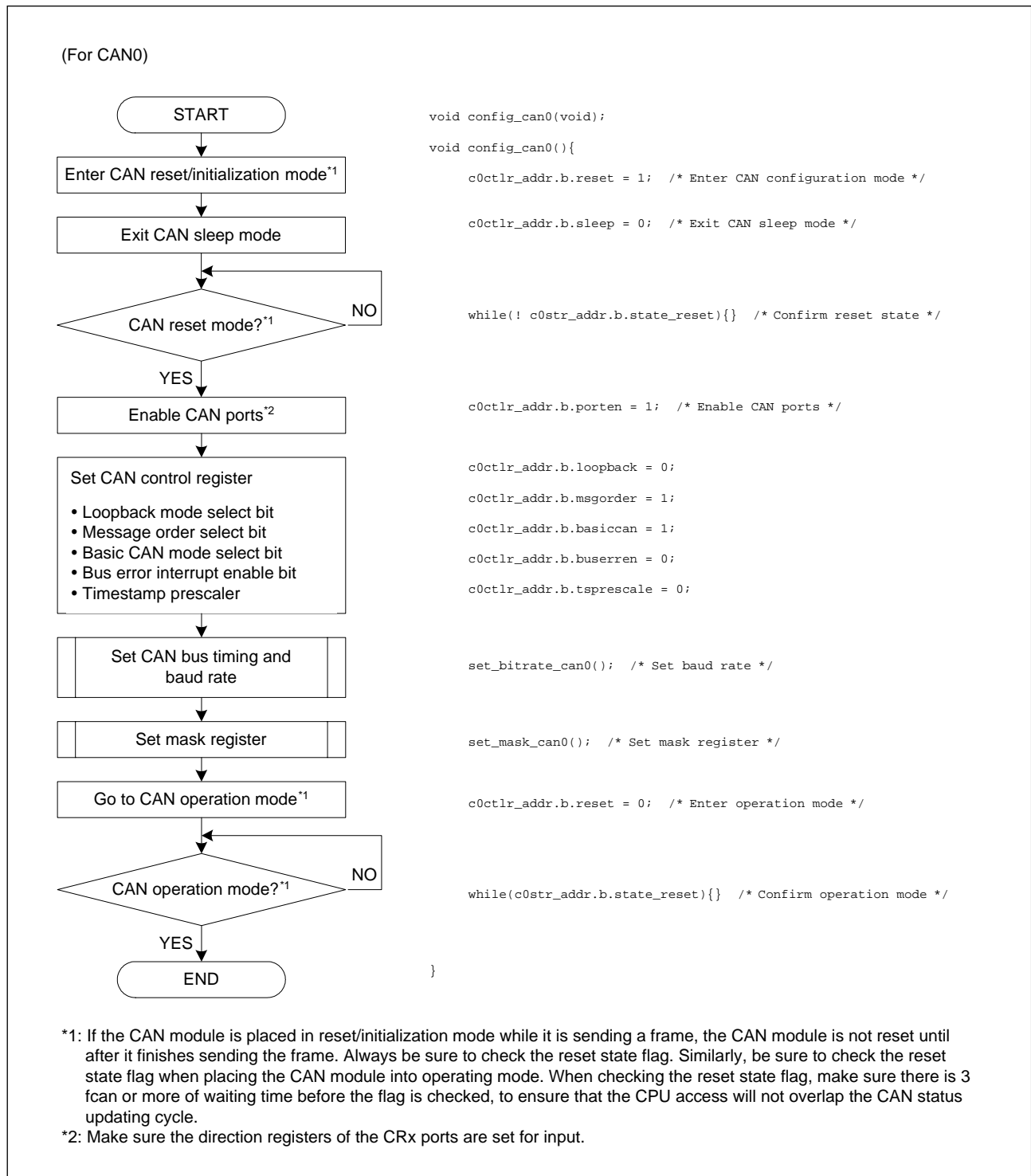

Figure 7 CAN configuration procedure

4.2 Message Transmission

There are following two modes of message transmission:

- Data frame transmit mode
- Remote frame receive/data frame transmit mode

(1) Data frame transmit mode

If any slot is placed in data frame transmit mode, the data frame set in that slot can be transmitted.

(2) Remote frame receive/data frame transmit mode

If any slot is placed in remote frame receive/data frame transmit mode, the data set in that slot can be automatically transmitted after receiving a remote frame that has the same ID as set in the slot. In this case, the number of data bytes to be transmitted is determined by the DLC value in the received remote frame.

4.2.1 Data Frame Transmit Mode

(1) Transmit procedure

When any slot is placed in data frame transmit mode, the data frame set in that slot can be transmitted.

If two or more slots are placed in data frame transmit mode at the same time, the data frames in those slots are transmitted in order of slot numbers, beginning with the smallest.

Figure 8 shows the data frame transmit procedure.

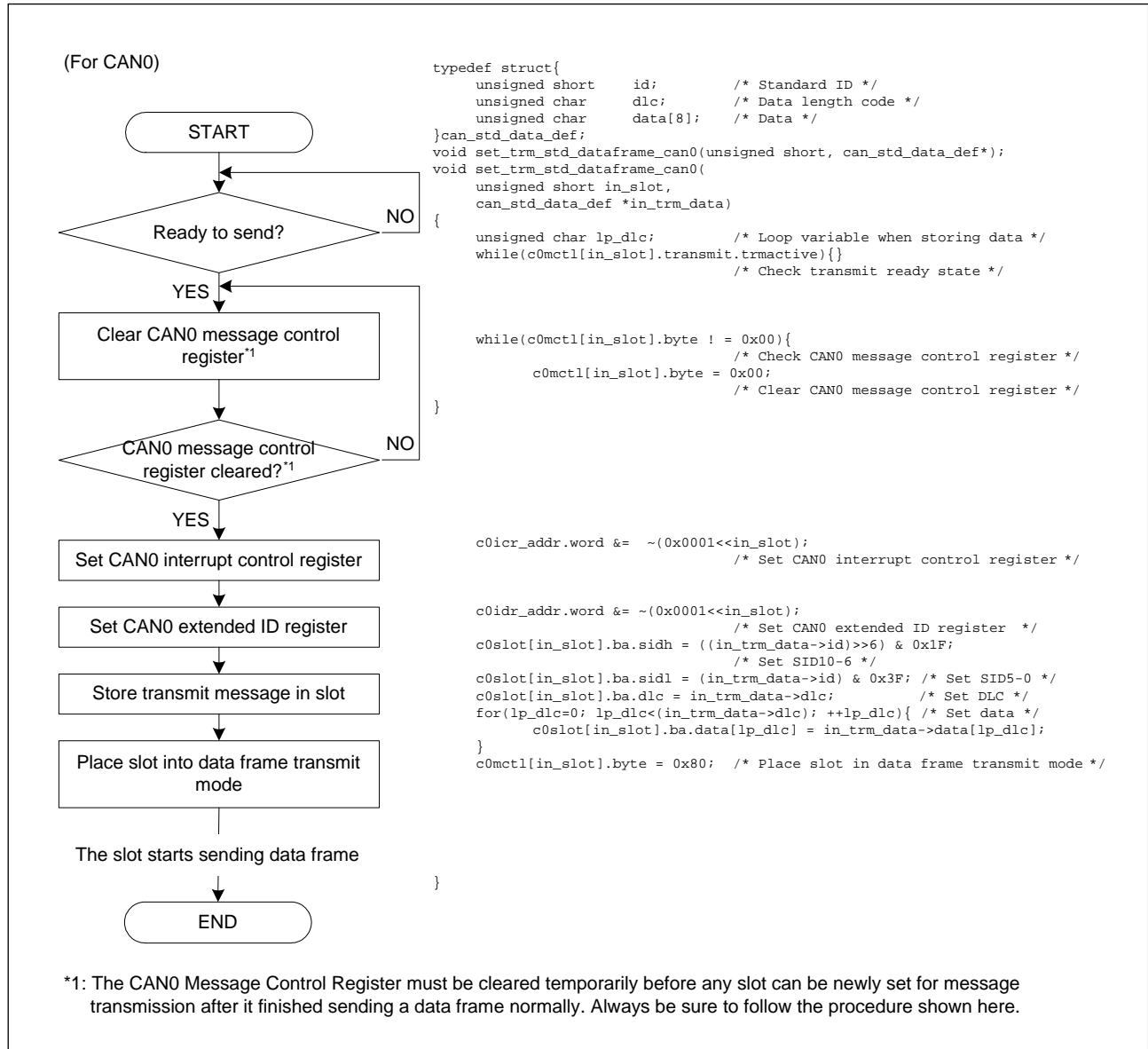

Figure 8 Data frame transmit procedure

(2) Procedure for confirming that transmission has terminated successfully

There are two methods to confirm that any slot has finished sending a message successfully. One method does this by polling, and the other by means of an interrupt.

- When confirming by polling

Whether a slot has finished sending a message successfully, can be confirmed by polling the CAN message control register.

Figure 9 shows the procedure for confirming by polling that a slot has finished sending a message successfully.

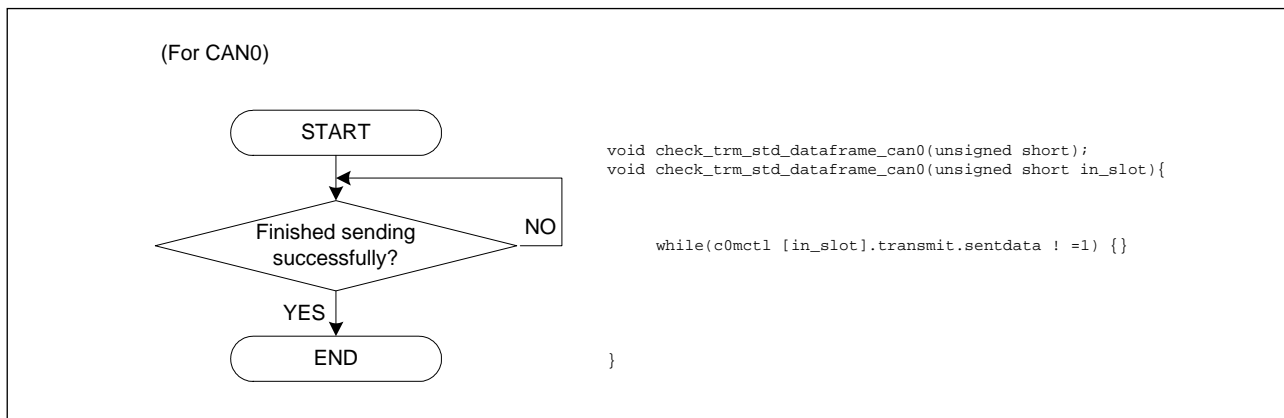

Figure 9 Procedure for confirming that transmission terminated successfully (by polling)

- When confirming by a CAN successful transmission interrupt

To use a CAN successful transmission interrupt for confirmation, enable the CAN successful transmission interrupt control register and then set the corresponding bit for each slot in the CAN interrupt control register to 1. This CAN interrupt control register is used in common for both CAN successful transmission and CAN successful reception interrupts. The CAN interrupt control register is automatically cleared when the CAN module goes to reset/initialization mode. Note that this register cannot be set during reset/initialization mode, and can only be set while the CAN module is in operating mode.

Figure 10 and Figure 11 show the procedure for setting the CAN successful transmission interrupt control register. Figure 12 shows the procedure for using a CAN successful transmission interrupt to confirm whether a slot has finished sending a message successfully.

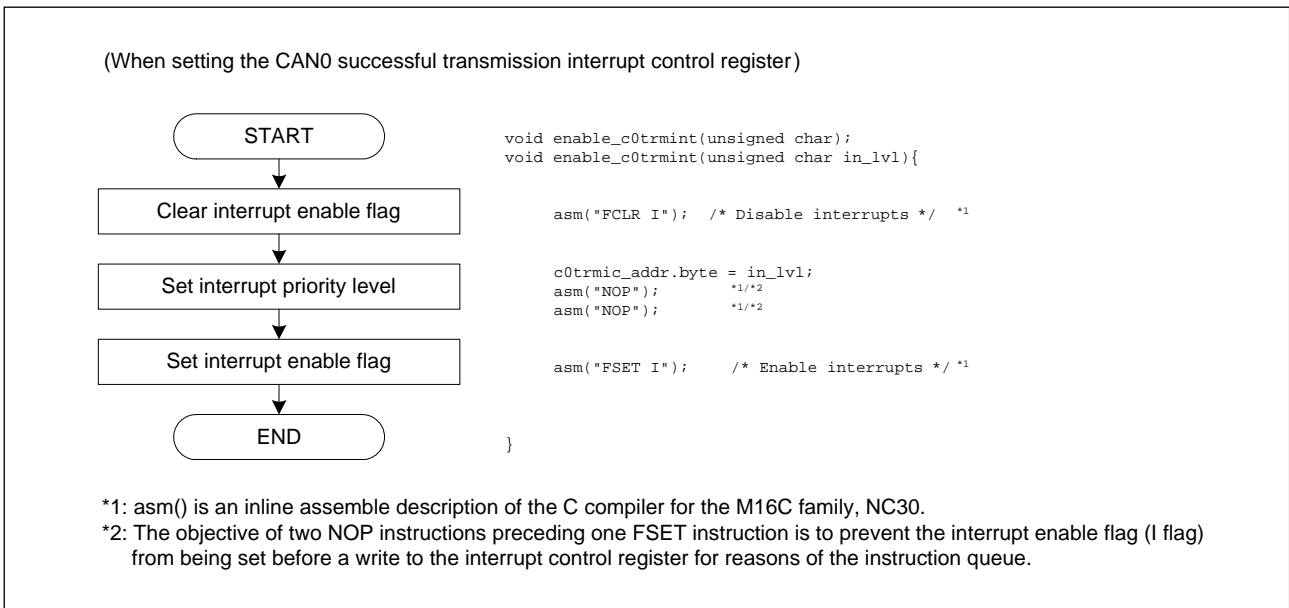

Figure 10 Procedure for setting the CAN0 successful transmission interrupt control register

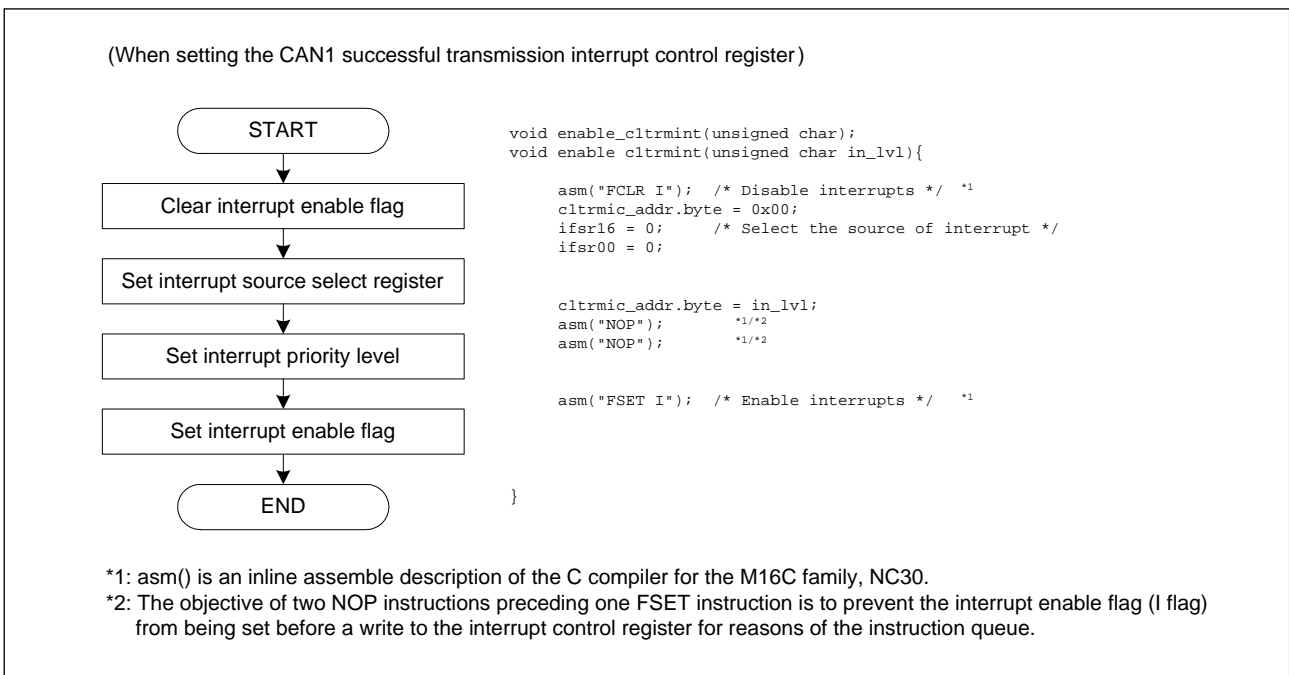

Figure 11 Procedure for setting the CAN1 successful transmission interrupt control register

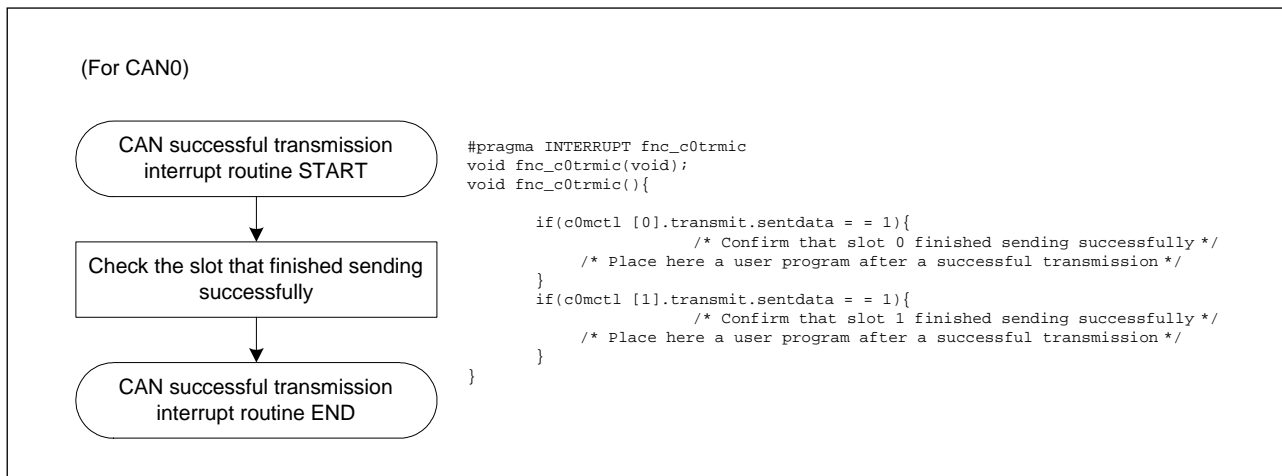

Figure 12 Procedure for confirming that a successful transmission (by a CAN successful transmission interrupt)

4.2.2 Remote Frame Receive/Data Frame Transmit Mode

When any slot is placed in remote frame receive/data frame transmit mode, the data set in that slot can be automatically transmitted after receiving a remote frame that has the same ID as set in the slot*1. In this case, the number of data bytes to be transmitted is determined by the DLC value in the received remote frame.

In remote frame receive/data frame transmit mode, it is possible to select whether or not to automatically respond to a received remote frame by setting the transmission/reception auto response lock mode select bit in the CAN message control register. (0: automatically respond; 1: not automatically respond.)

When selected to automatically respond, the slot automatically starts sending a data frame after receiving a remote frame. When selected not to automatically respond, set this bit to 0, and the slot will start sending a data frame after receiving a remote frame.

Figure 13 and Figure 14 show the remote frame receive/data frame transmit procedure.

*1: When operating in Basic CAN mode, slots 14 and 15 cannot be placed in remote frame receive/data frame transmit mode. For details, refer to Section 4.5.

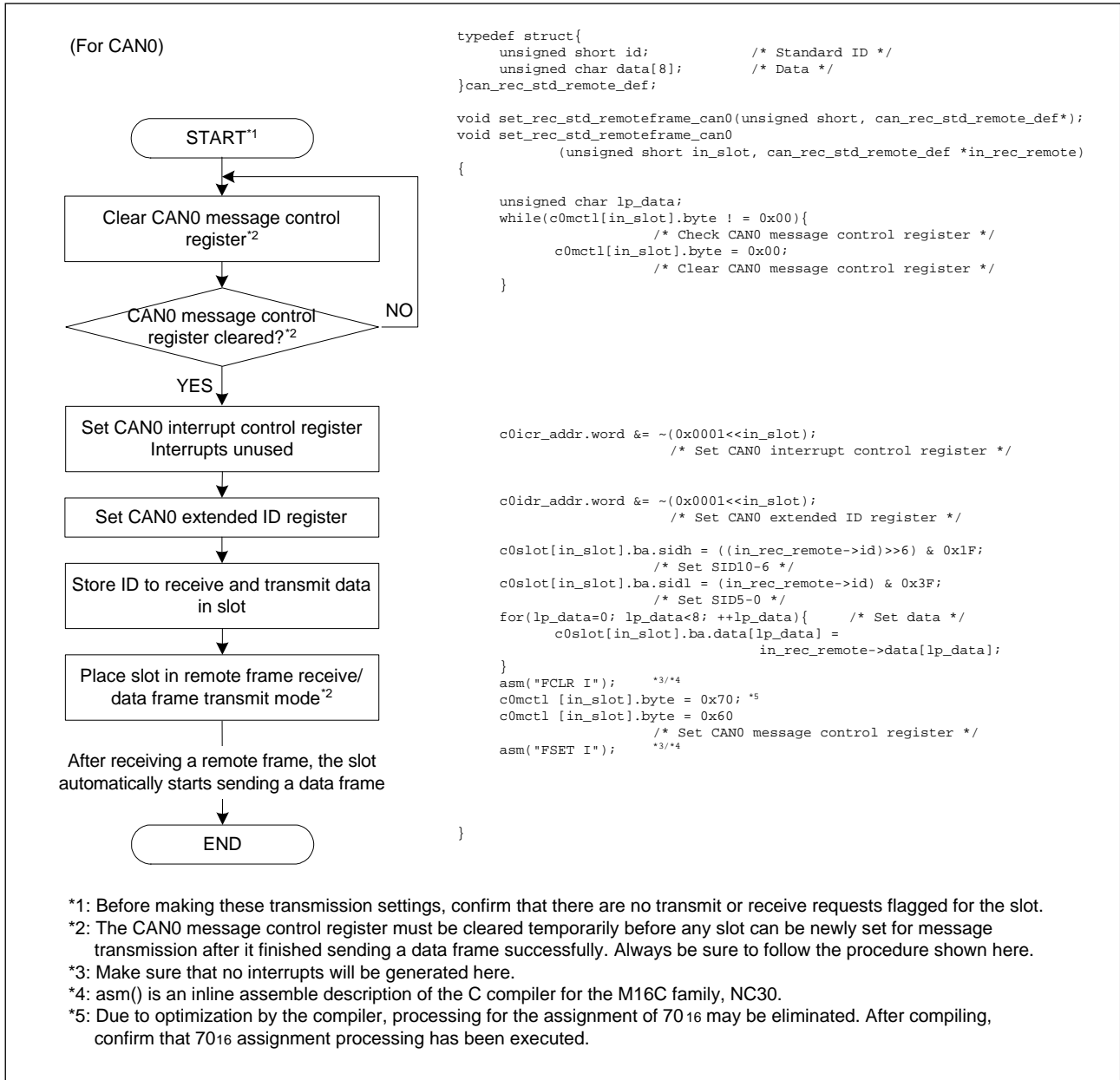

Figure 13 Remote frame receive/data frame transmit procedure
(for automatically responding to a received remote frame)

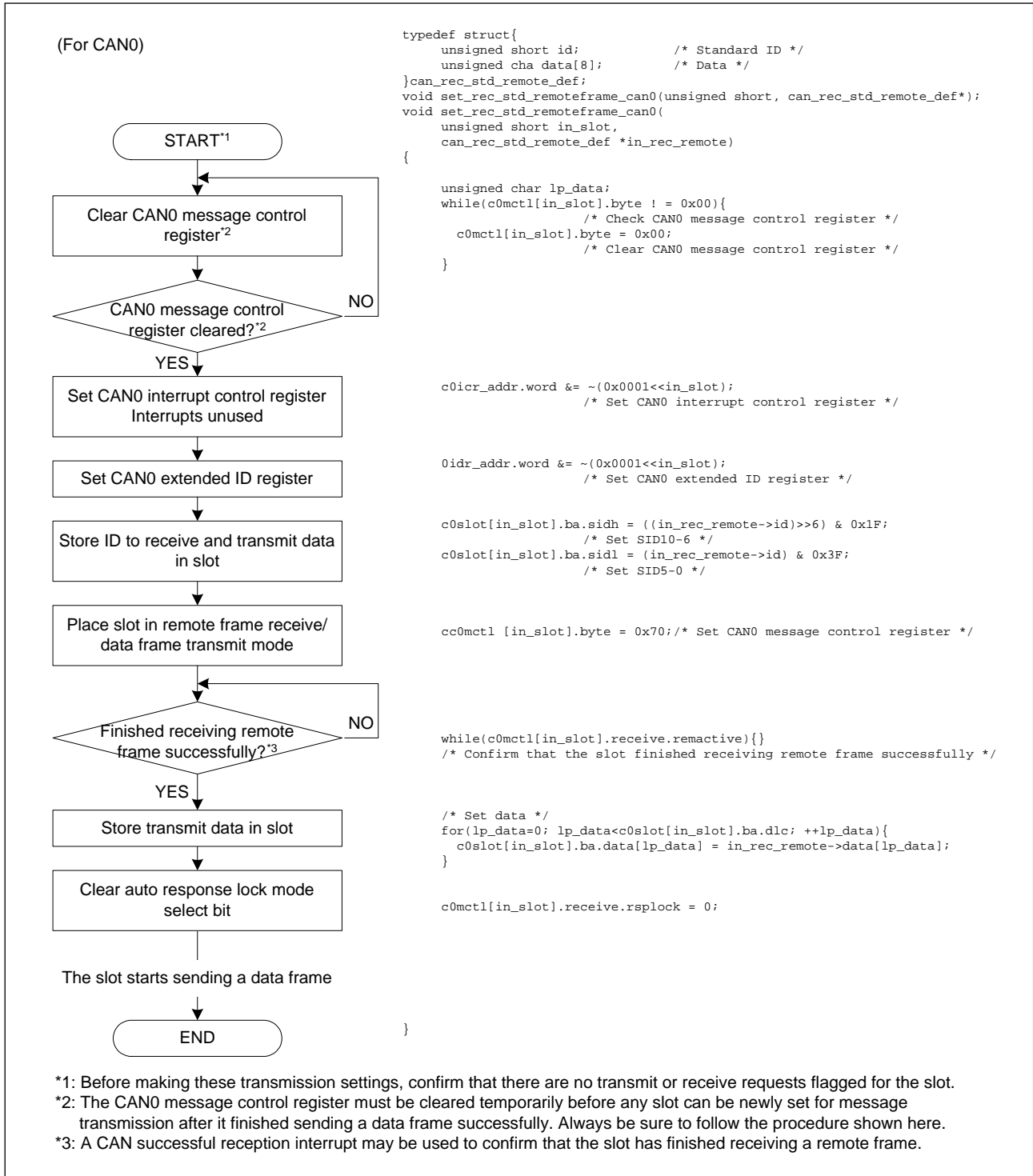

Figure 14 Remote frame receive/data frame transmit procedure
(when not automatically responding to a received remote frame)

4.2.3 Abort Transmission

If two or more nodes started sending messages at the same time, the nodes whose messages have lower priority than the other may be lost in arbitration and abort the transmission. (They will re-send messages after the node whose message won the arbitration has finished sending.) Any nodes will not be able to finish sending a message successfully unless they win the arbitration, so that they will perpetually repeat a retransmission and cannot send a new message. To solve this problem, the CAN module has a function to cancel the message being retransmitted, which is referred to as the transmission abort function. This function may prove effective when it is desired to set a limit time for one message transmitted or there is an urgent high priority message to be transmitted.

Figure 15 shows an example application of the transmission abort function.

Abort transmission is executed by clearing the CAN message control register.

(1) Conditions under which a transmission abort request is effective

- When the node has been sending a data frame or a remote frame
 Abort transmission is effective only when the transmit slot setting bit in the CAN message control register = 1.
- When the node has been sending a data frame after receiving a remote frame
 Abort transmission is effective only when the receive slot setting bit in the CAN message control register = 1.

(2) Conditions under which abort transmission is executed

- When the message lost in arbitration (see Figure 16 and Figure 17).
- When an error occurred during message transmission (see Figure 16 and Figure 17).

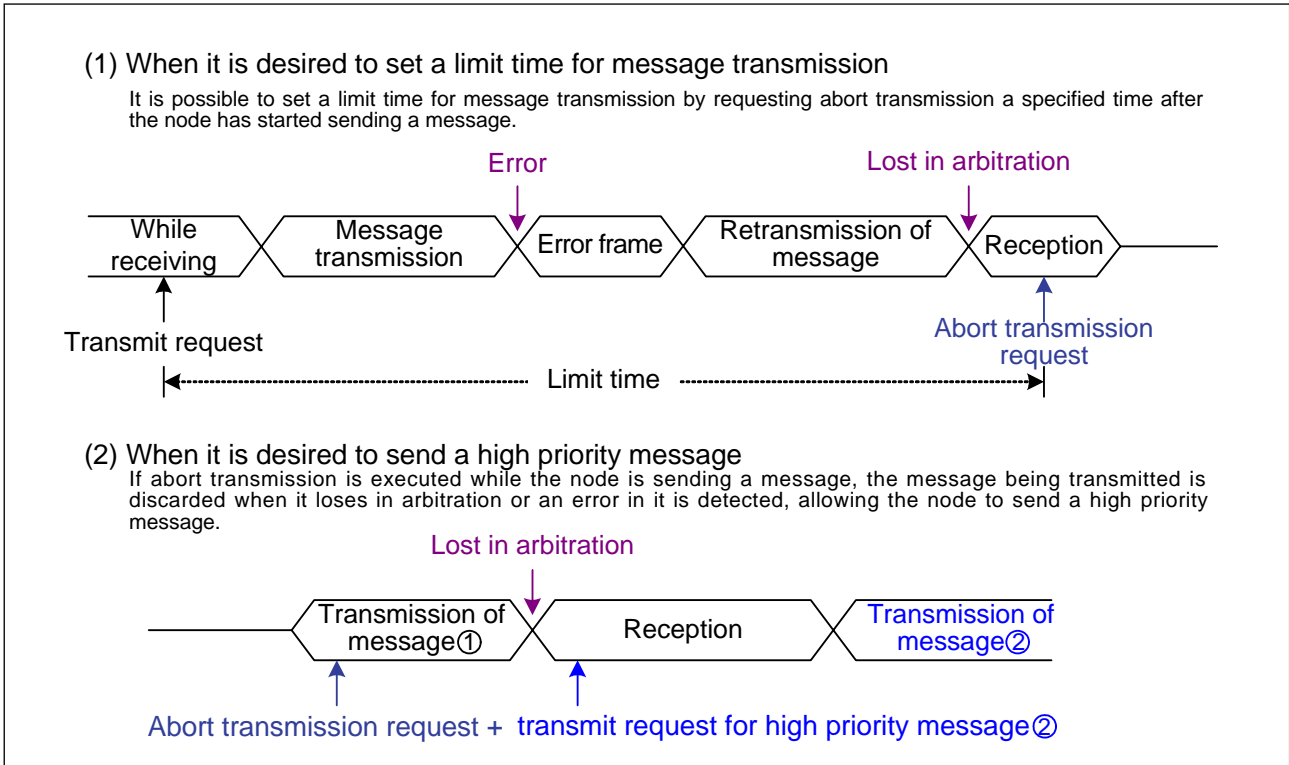

Figure 15 Example application of the transmission abort function

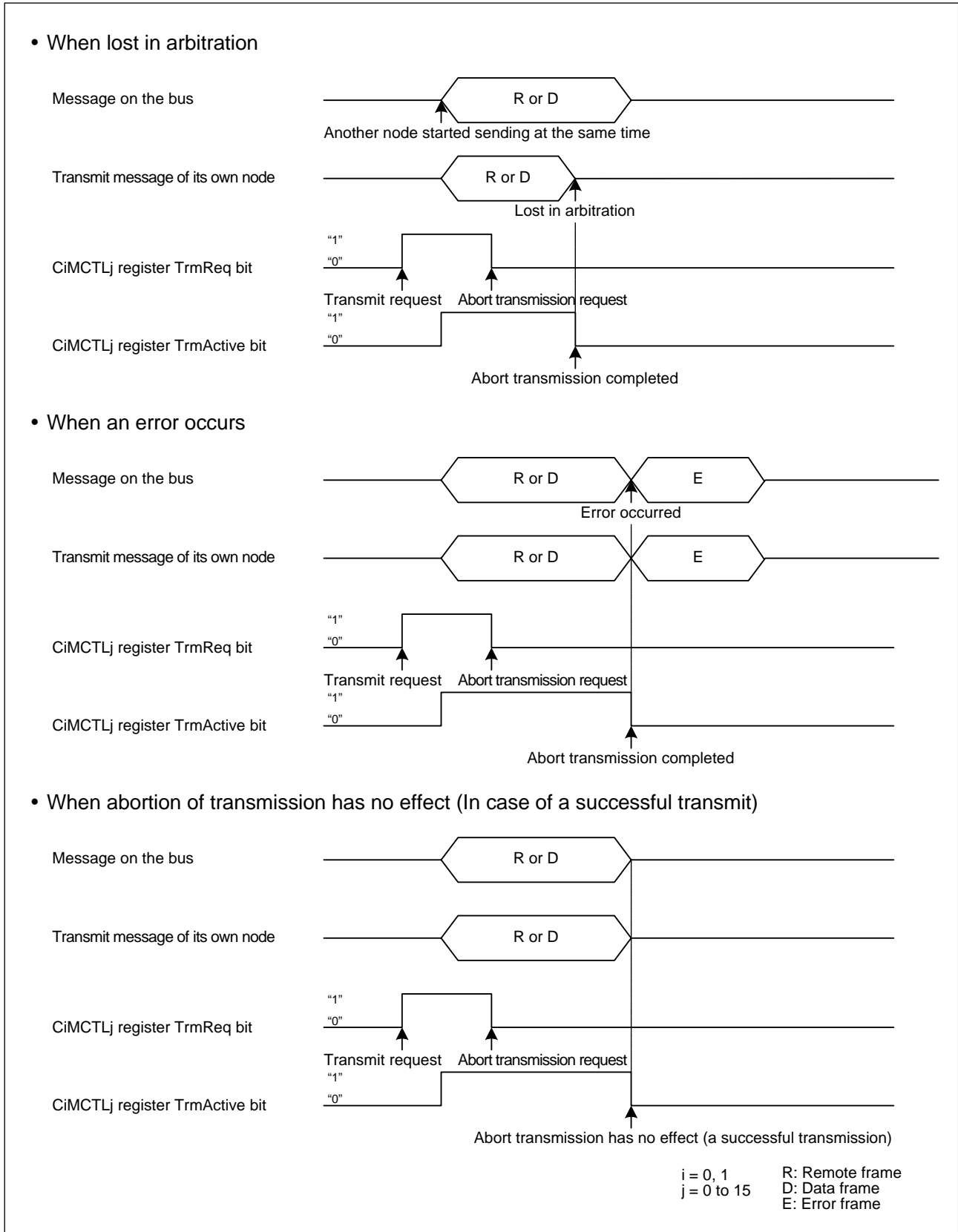

Figure 16 Abort transmission while sending a remote frame or data frame

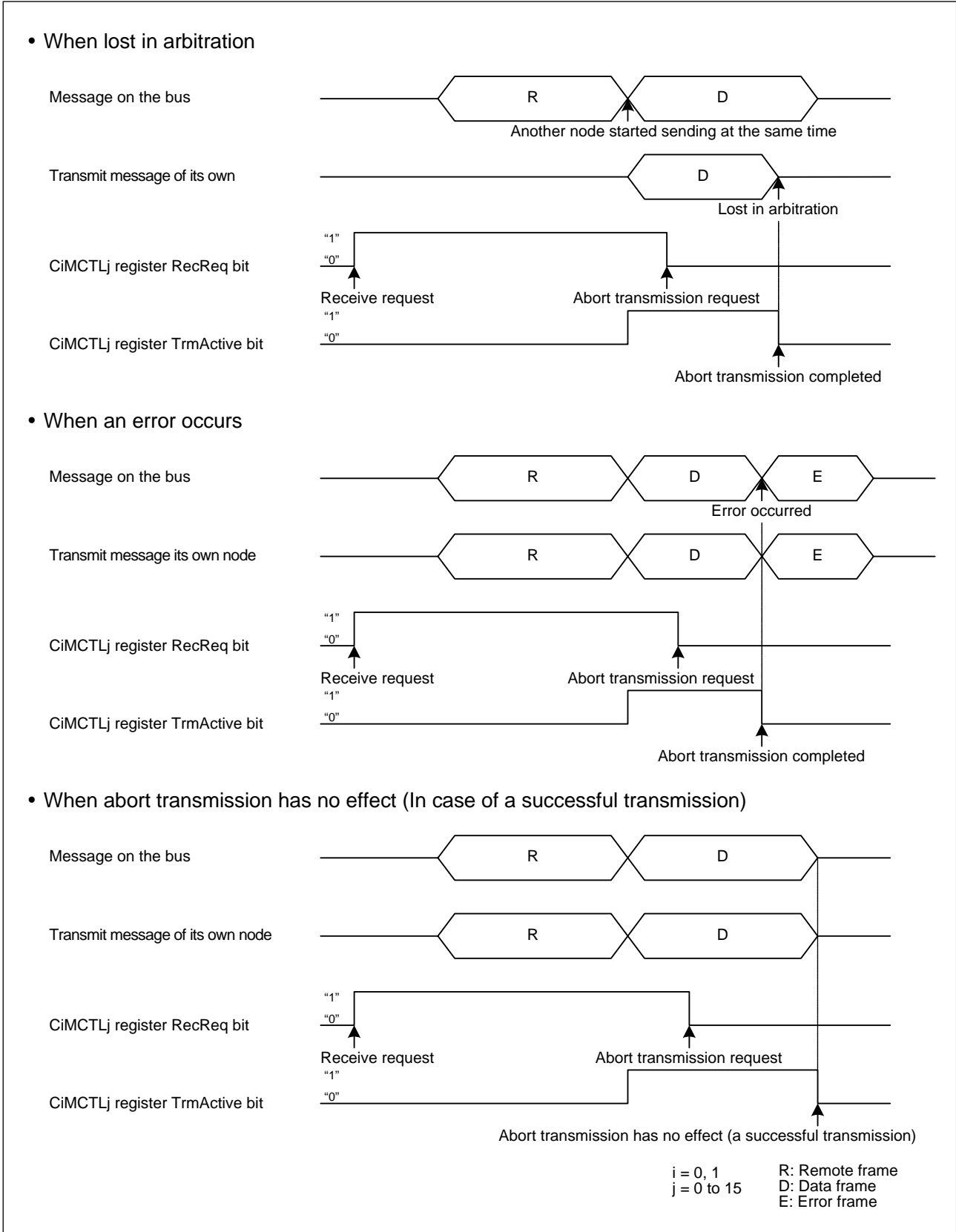

Figure 17 Abort transmission while sending a data frame after receiving a remote frame

(3) Abort transmission procedure

Figure 18 shows the procedure for abort transmission.

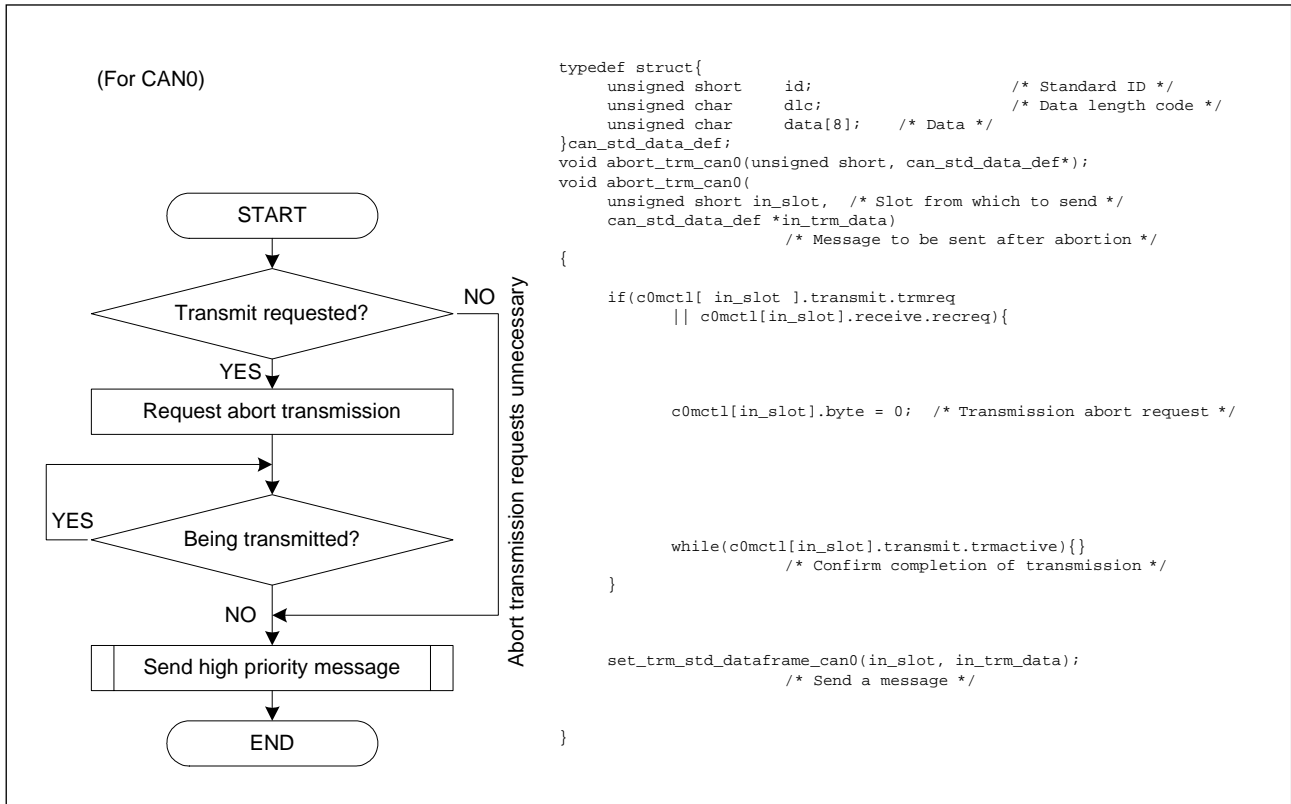

Figure 18 Abort transmission procedure

4.3 Receiving Messages

The CAN module has 16 slots per channel, of which unless the acceptance filter is used, the received message is stored in the slot with the smallest slot number of those that have been set for reception. If the acceptance filter is used, it is possible to select the message to receive. For details about the acceptance filter, refer to Section 6.

There are following two modes of message reception.

- Data frame receive mode
- Remote frame transmit/data frame receive mode

(1) Data frame receive mode

If any slot is placed in data frame receive mode, the data frame that has the same ID as set in that slot can be received.

(2) Remote frame transmit/data frame receive mode

If any slot is placed in remote frame transmit/data frame receive mode, after a remote frame with its ID and DLC set in that slot is sent, the data frame that has the same ID as transmitted can be automatically received.

4.3.1 Data Frame Receive Mode

(1) Reception setup procedure

If the CAN module has been set to receive data frames with the same ID in two or more slots, the received message is always stored in the slot with the smallest slot number.

Figure 19 shows the procedure for setting up the CAN module to receive data frames.

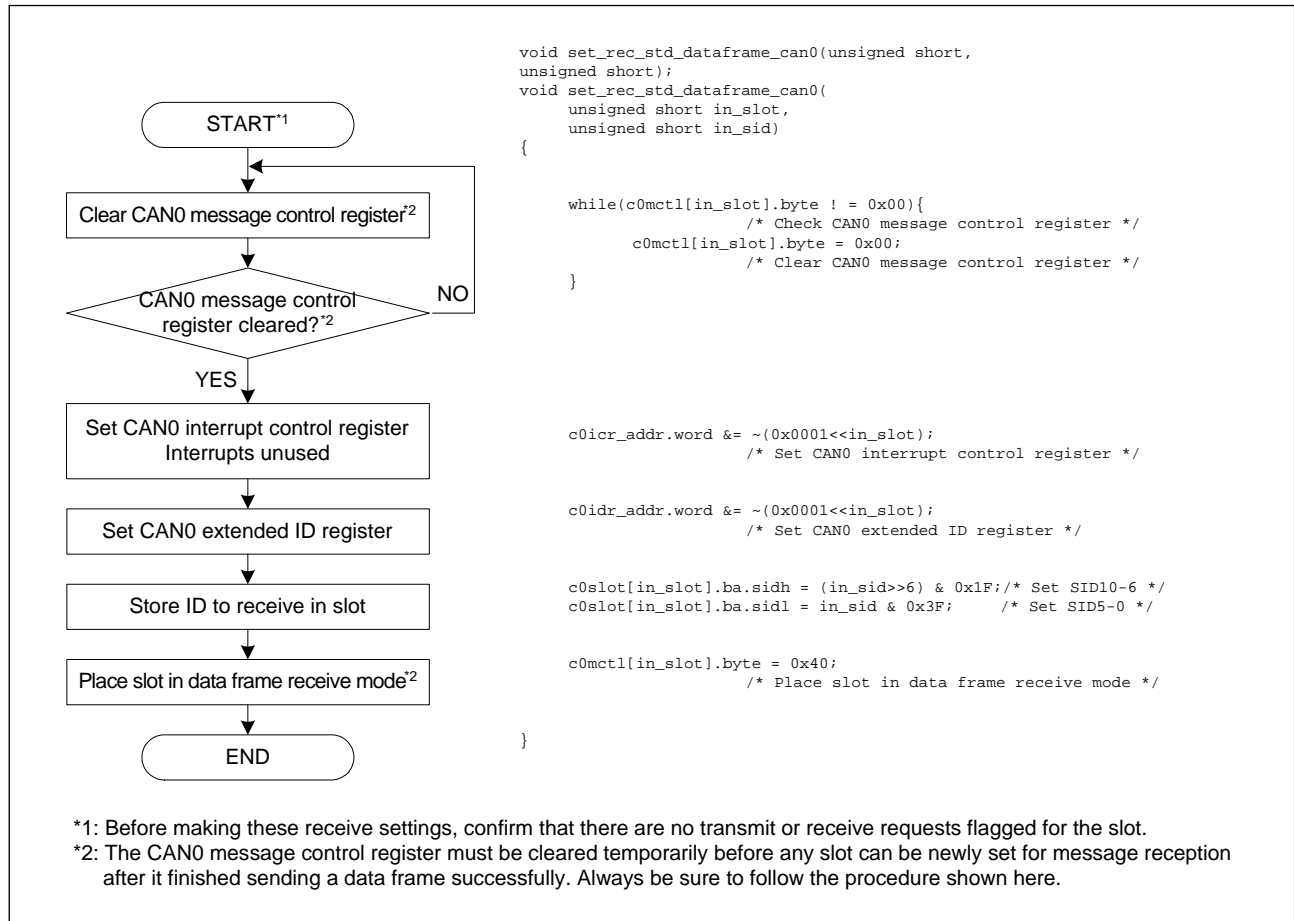

Figure 19 Procedure for setting up to receive data frames

(2) Procedure for processing the received message

Figure 20 shows the procedure for processing the received message.

If any slot has finished receiving another message after it finished receiving successfully normally, the slot will be overwritten with the new message received. For details, refer to Section 4.4. Therefore, after the software has finished reading the received message out of the slot, it is necessary to confirm that the slot has not been overwritten during readout.

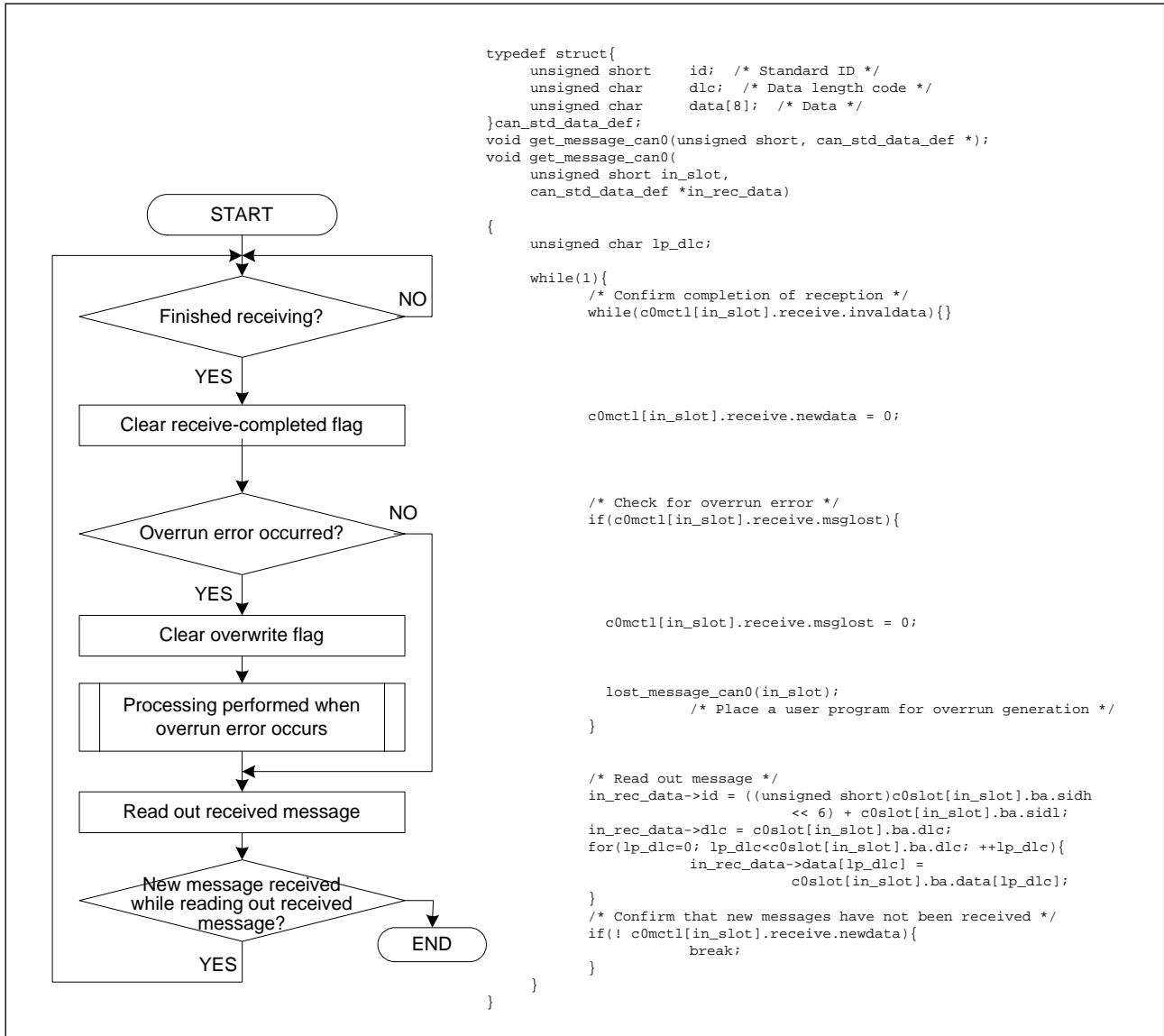

Figure 20 Procedure for processing the received message

(3) Procedure for confirming that reception has terminated successfully

There are two methods to confirm that any slot has finished receiving a message successfully. One method does this by polling, and the other by means of an interrupt.

- When confirming by polling

Whether a slot has finished receiving a message successfully can be confirmed by polling the CAN message control register.

Figure 21 shows the procedure for confirming by polling that a slot has finished receiving a message successfully.

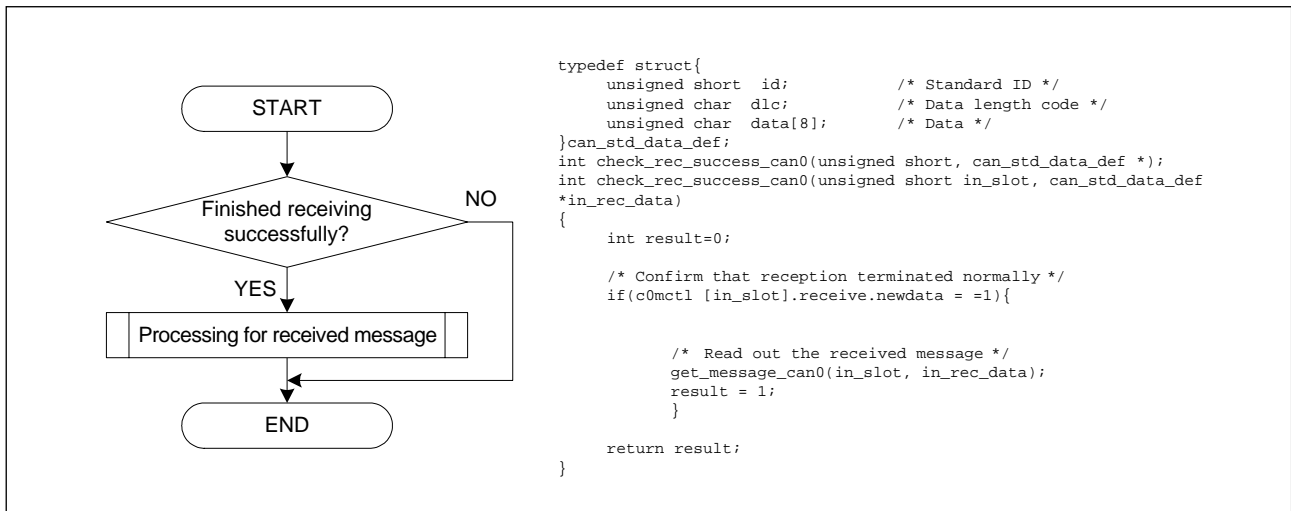

Figure 21 Procedure for confirming that reception successfully (by polling)

- When confirming by a CAN successful interrupt
To use a CAN successful interrupt for confirmation, enable the CAN successful interrupt control register and then set the corresponding bit for each slot in the CAN interrupt control register to 1. This CAN interrupt control register is shared by CAN successful transmission interrupt and CAN successful reception interrupt. The CAN interrupt control register is automatically cleared when the CAN module goes to reset/initialization mode. Note that this register cannot be set during reset/initialization mode, and can only be set while the CAN module is in operating mode. Figure 22 and Figure 23 show the procedure for setting the CAN successful reception interrupt control register. Figure 24 shows the procedure for using a CAN successful reception interrupt to confirm whether a slot has finished receiving a message successfully.

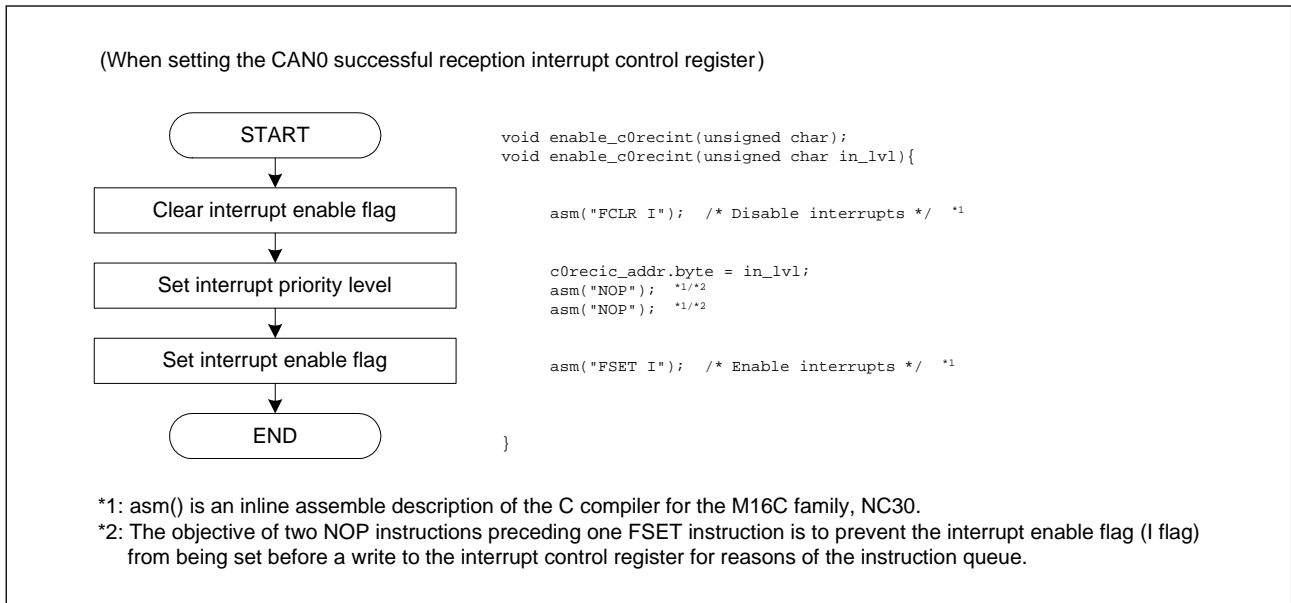

Figure 22 Procedure for setting the CAN0 successful reception interrupt control register

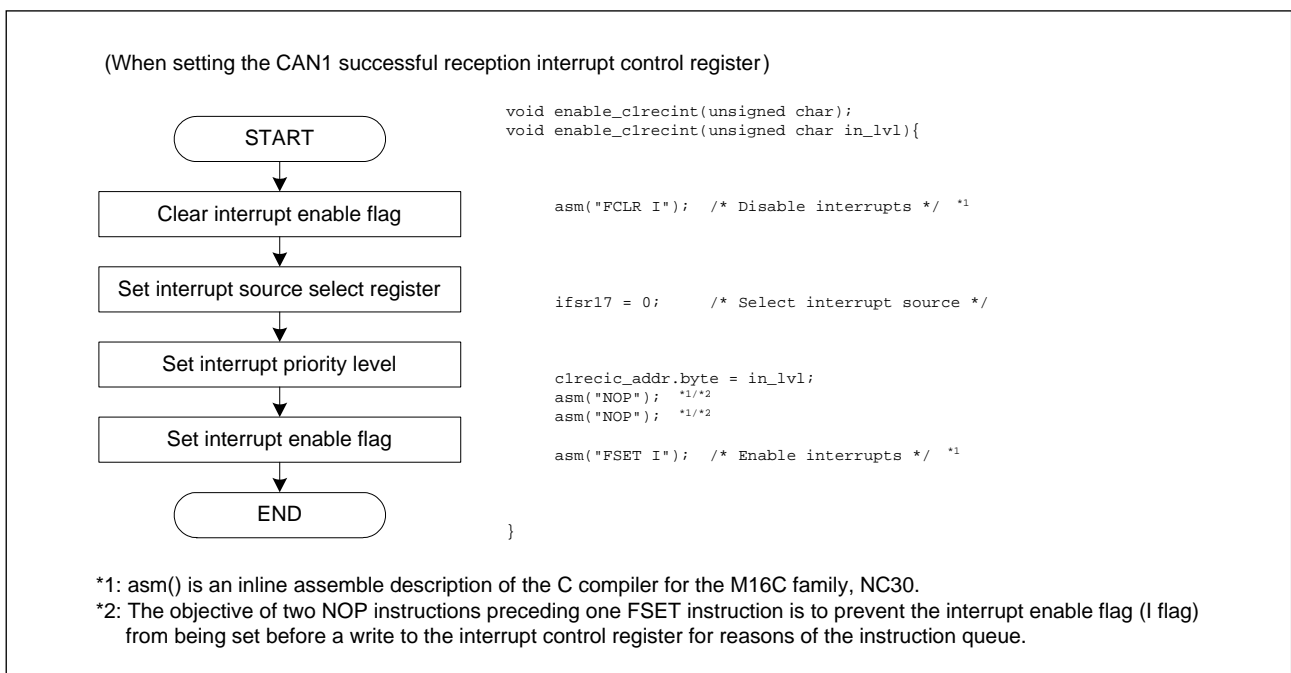

Figure 23 Procedure for setting the CAN1 successful reception interrupt control register

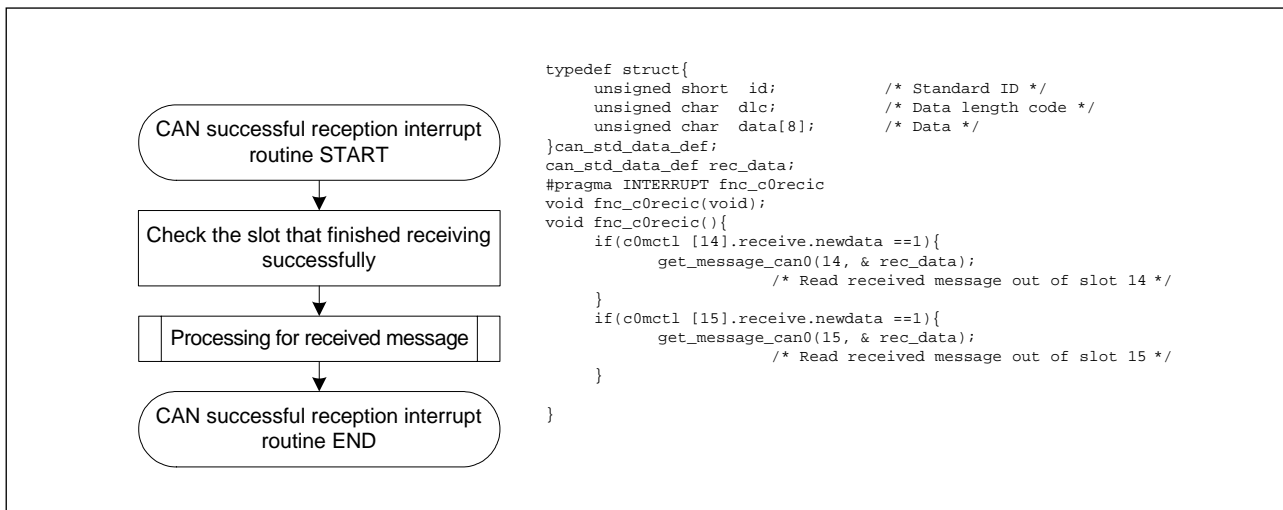

Figure 24 Procedure for confirming a successful transmission (by a CAN successful reception interrupt)

4.3.2 Remote Frame Transmit/Data Frame Receive Mode

If any slot is placed in remote frame transmit/data frame receive mode, after a remote frame with its ID and DLC set in that slot is sent, the data frame that has the same ID as transmitted can be automatically received. However, if a data frame that has the same ID as set in the slot is received, the remote frame is not transmitted.

Figure 25 shows the procedure for receiving a data frame after sending a remote frame, in which confirmation of reception is made by polling.

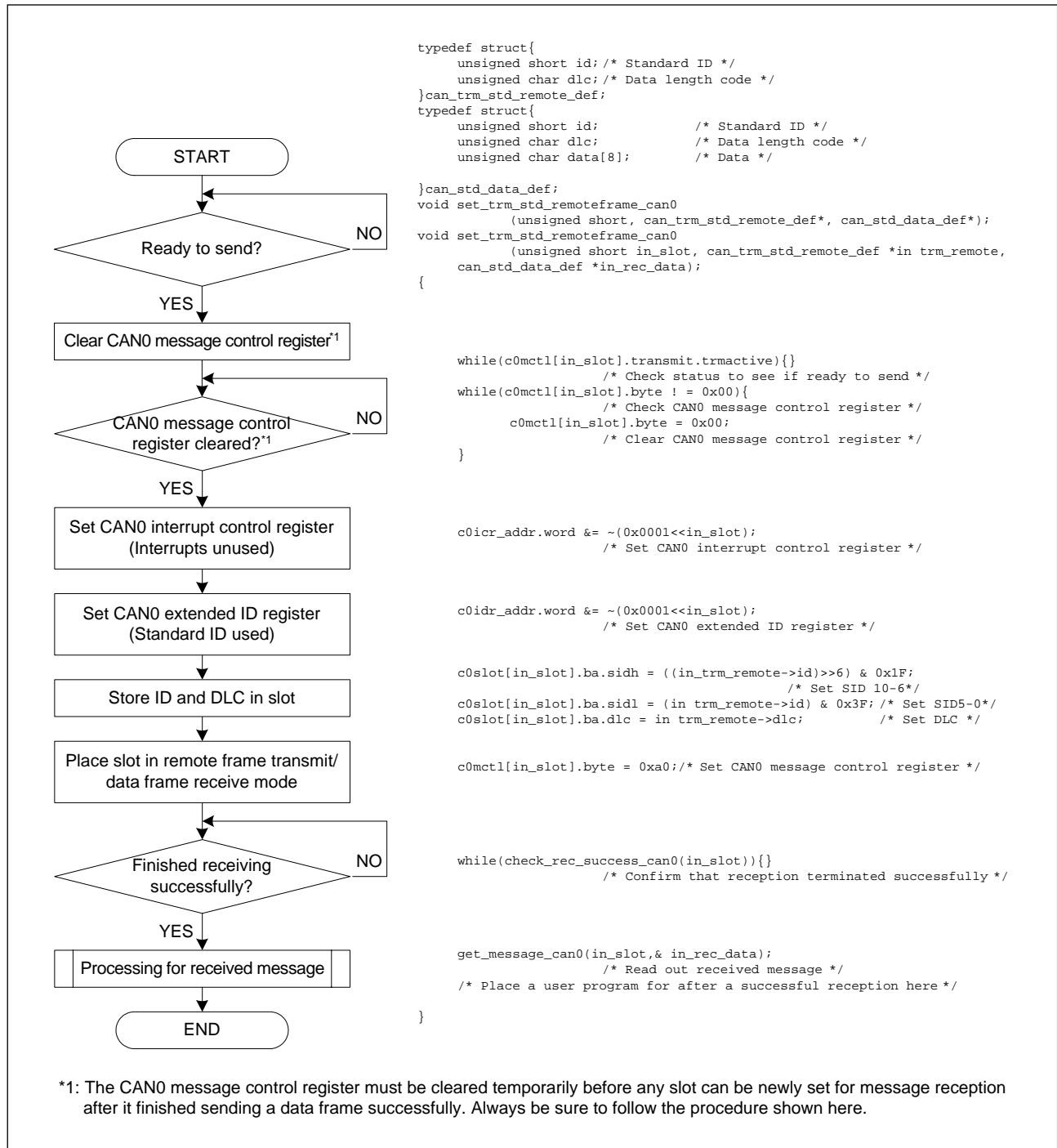

Figure 25 Procedure for receiving a data frame after sending a remote frame

4.4 CAN Overrun Error

If messages are received successively, the content of the slot is overwritten with the next message received.

If the successful reception flag is set to 0 by a program or the next CAN message is received successfully before the reception request for the slot is canceled, the overwrite flag is set to 1. In such a case, processing for the previous message to be retransmitted should be executed in programs on transmit and receive sides.

For details on how to process the received message, refer to Figure 20.

4.5 Basic CAN Mode

The CAN module has 16 slots per channel, each of which can be set for transmission or reception. This is referred to as normal operation mode.

In Basic CAN mode, slots 14 and 15 operate as receive slots, and slots 0 to 13 operate in normal operation mode. During this mode, the received messages are stored alternately in slots 14 and 15.

In normal operation mode, depending on how the CAN message control register is set, each slot can handle only one type of message at a time, either a data frame or a remote frame. In Basic CAN mode, however, slots 14 and 15 can receive both types of messages at the same time. Which type of message has been received can be determined by checking the remote frame transmission/reception status flag in the CAN message control register. The remote frame transmission/reception status flag is 0 when a data frame has been received and 1 when a remote frame has been received.

Basic CAN mode can be selected by setting the Basic CAN mode select bit in the CAN control register to 1 (= Basic CAN mode).

When using Basic CAN mode, observe the following precautions:

- Basic CAN mode can only be set during reset/initialization mode.
- Slots 14 and 15 must be set for reception.
- Slots 14 and 15 must have the same ID set in each. Also, the local mask register A and local mask register B for slots 14 and 15 must be set in the same way.
- Even during Basic CAN mode, if any slot receives a new message while it is receiving another message, the slot may be overwritten by the new message received.

Figure 26 shows the procedure for confirming that reception has terminated normally during Basic CAN mode.

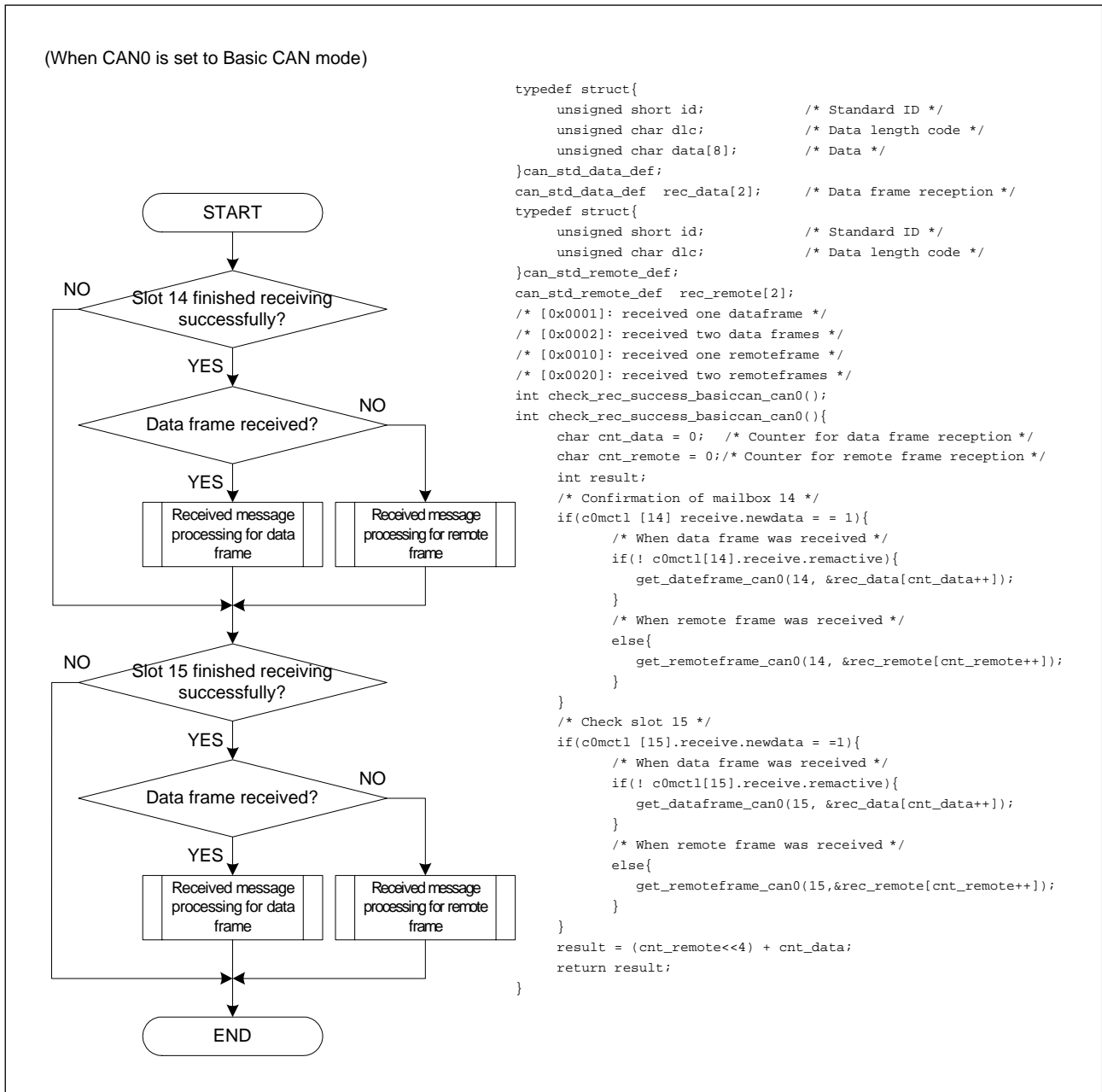

Figure 26 Procedure for confirming a successful receive in Basic CAN mode

5. CAN Errors

The CAN module has an interrupt facility for CAN errors, making it possible to confirm in this CAN error interrupt that a communication error has occurred.

If while a slot is sending or receiving the communication frame becomes erratic and an error is detected, the transmit error counter or receive error counter may increase depending on the transmit/receive status. When the transmit error counter or receive error counter exceeds 128, the CAN status changes from an error-active state to an error-passive state. When the transmit error counter exceeds 256, a bus-off state is entered.

If the bus error interrupt enable bit in the CAN control register is 1 (= bus error interrupt enabled), a CAN error interrupt is generated each time an error is detected.

If the bus error interrupt enable bit in the CAN control register is 0 (= bus error interrupt disabled), a CAN error interrupt is generated when an error-passive state or a bus-off state is entered.

Note that the bus error interrupt enable bit can only be set during CAN configuration. Before the CAN error interrupt can be used, the CAN error interrupt control register must be set.

Figure 27 shows the procedure for setting up the CAN error interrupt control register.

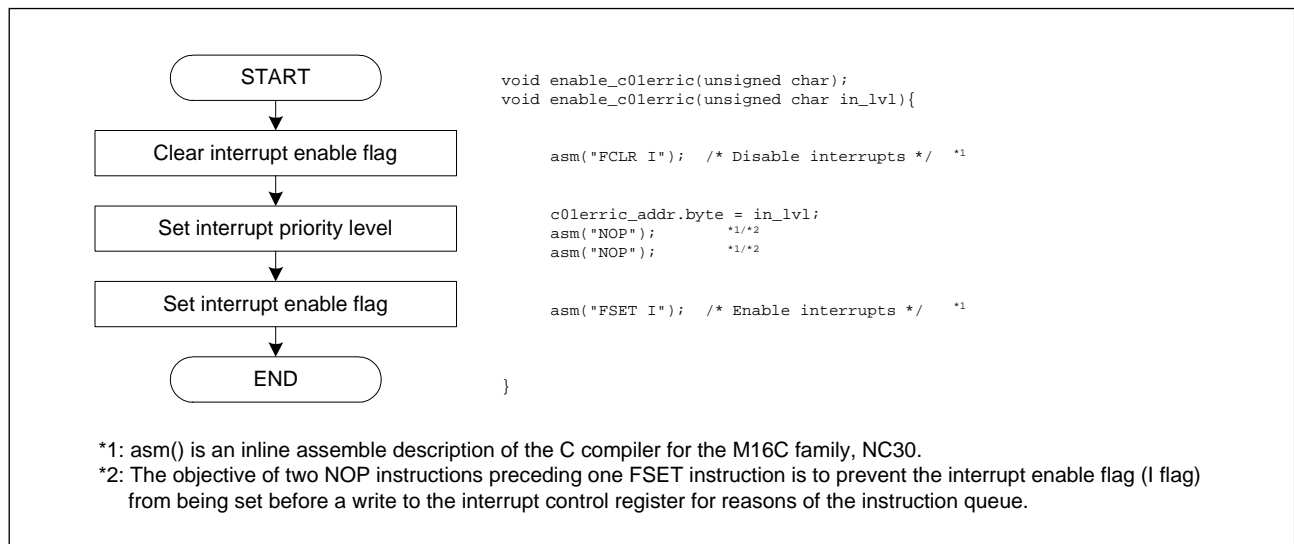

Figure 27 Procedure for setting up the CAN error interrupt control register

5.1 CAN Error Confirmation Procedure

There are two methods to confirm the CAN error state. One method does this by polling, and the other by means of an interrupt.

- Confirmation by polling
The CAN error state can be confirmed by polling the bus-error state, error-passive state, and bus-off state flags in the CAN status register.

Figure 28 shows the procedure for confirming the CAN error state by polling.

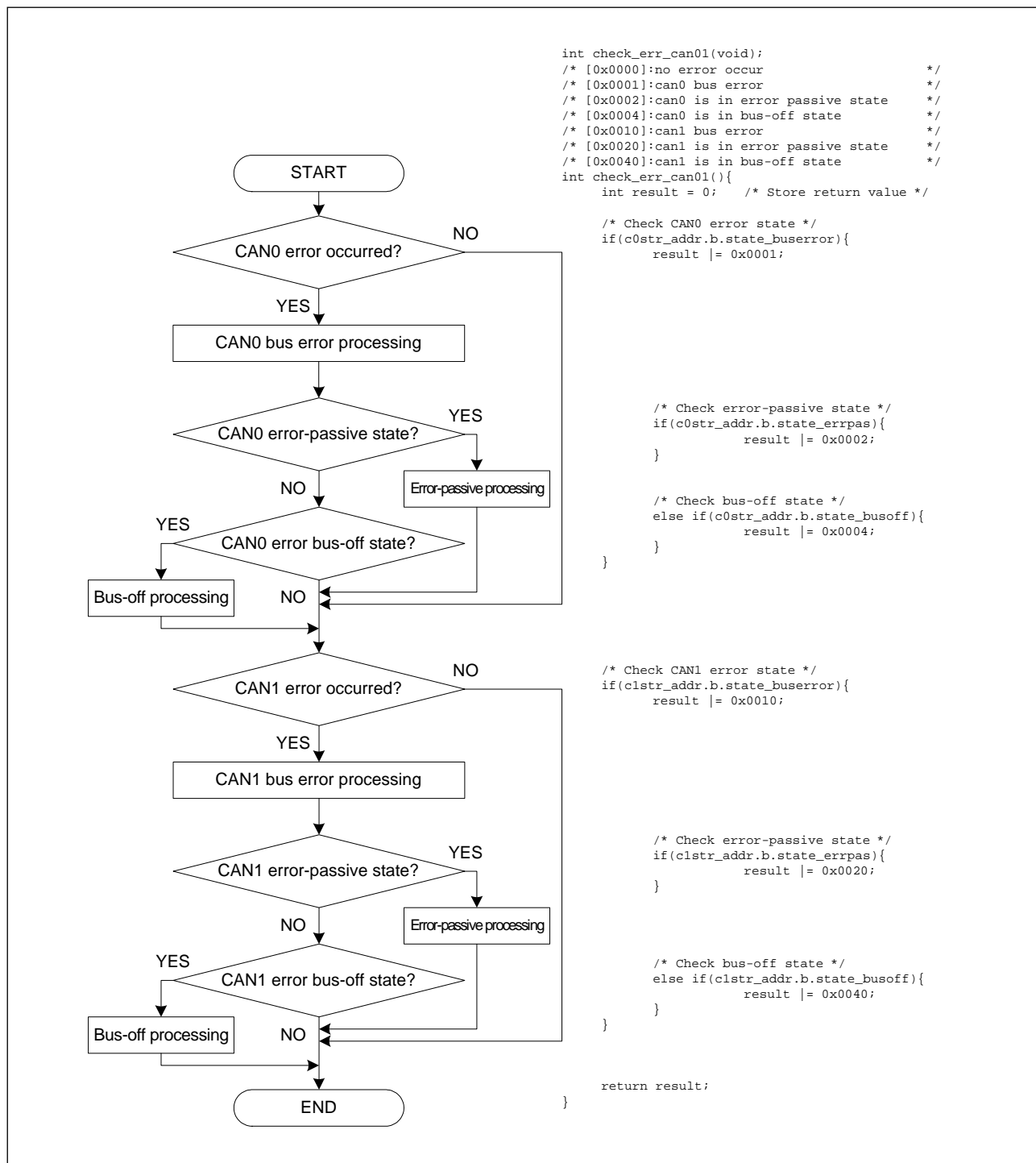

Figure 28 Procedure for checking the CAN error state (by polling)

- Confirmation by means of a CAN error interrupt

The CAN error interrupt becomes usable by setting up the CAN error interrupt control register to enable the interrupt. In this CAN error interrupt routine it is possible to check the CAN error state. This CAN error interrupt is shared by CAN0 and CAN1.

Figure 29 shows the procedure for confirming the CAN error state by means of a CAN error interrupt.

Here, the error state is checked in the CAN error interrupt routine and if the error state is confirmed to be a bus-off state, return from bus-off is executed.

For details about return from bus-off, refer to Section 5.2.

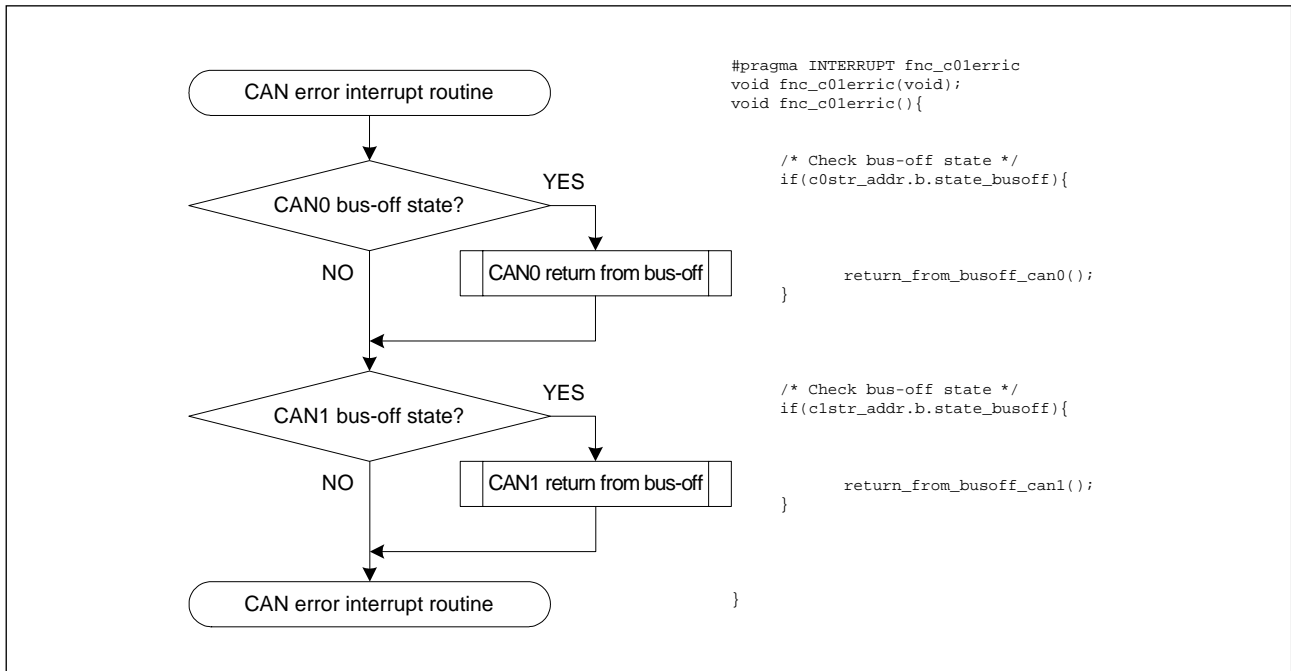

Figure 29 Procedure for confirming the CAN error state (by means of a CAN error interrupt)

5.2 Return from Bus-off Function

If the CAN status goes to a bus-off state, the CAN module becomes unable to transmit or receive. Before the CAN module can enter an error-active state where it can transmit and receive, it must wait until 11 consecutive recessive bits are detected on the bus as many as 128 times. However, if there is an urgent message to be sent, for example, the CAN module may need to be placed in an error-active state immediately. Therefore a function known as "Return from Bus-off" is provided that allows the CAN module to enter an error-active state without waiting for the above period.

The return from bus-off function is executed by setting the return from bus-off command bit in the CAN control register to 1 (= forcible return from bus-off). The return from bus-off command bit is automatically cleared after return from bus-off is executed. When return from bus-off is executed, note that CAN configuration does not need to be performed after an error-active state is entered.

The return from bus-off function is effective only when the CAN module is in a bus-off state. If an attempt is made to execute return from bus-off while the CAN module is in an error-active or an error-passive state, the attempt is ignored and the forcible return from bus-off Instruction bit is cleared immediately.

Figure 30 shows an example execution of the return from bus-off function.

Here, the CAN0 and CAN1 error states are checked in the CAN error interrupt routine and if the error state is confirmed to be a bus-off state, return from bus-off is executed.

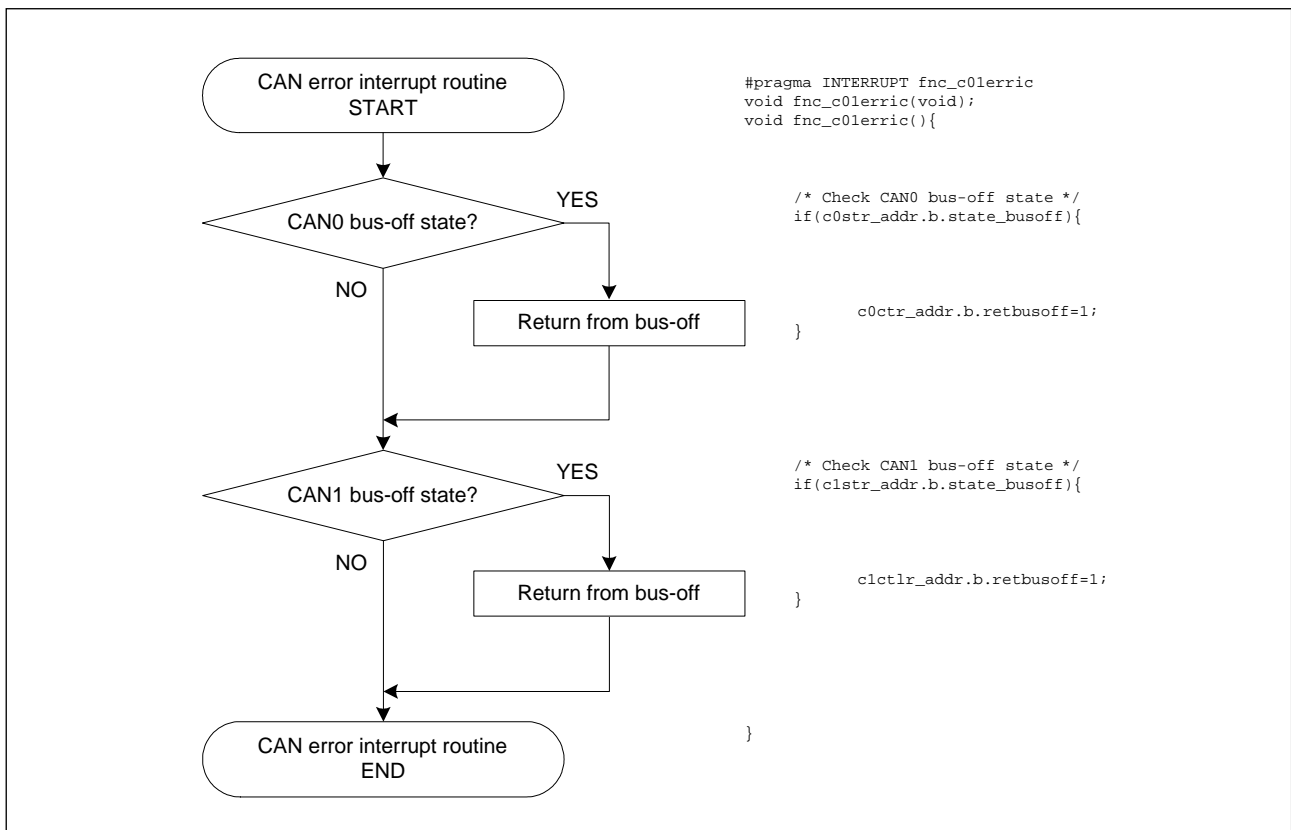

Figure 30 Example execution of the return from bus-off function

6. Using the Acceptance Filter

A function known as the acceptance filter is available that allows messages to be received or discarded in hardware.

6.1 Acceptance Filter (ACP)

The acceptance filter uses the global mask register (for slots 0 to 13), local mask register A (for slot 14), and local mask register B (for slot 15) for filtering of messages.

(1) Register structure of the acceptance filter

Figure 31 shows the structure of ID and the mask register. Figure 32 and Figure 33 show memory maps and bit assignments.

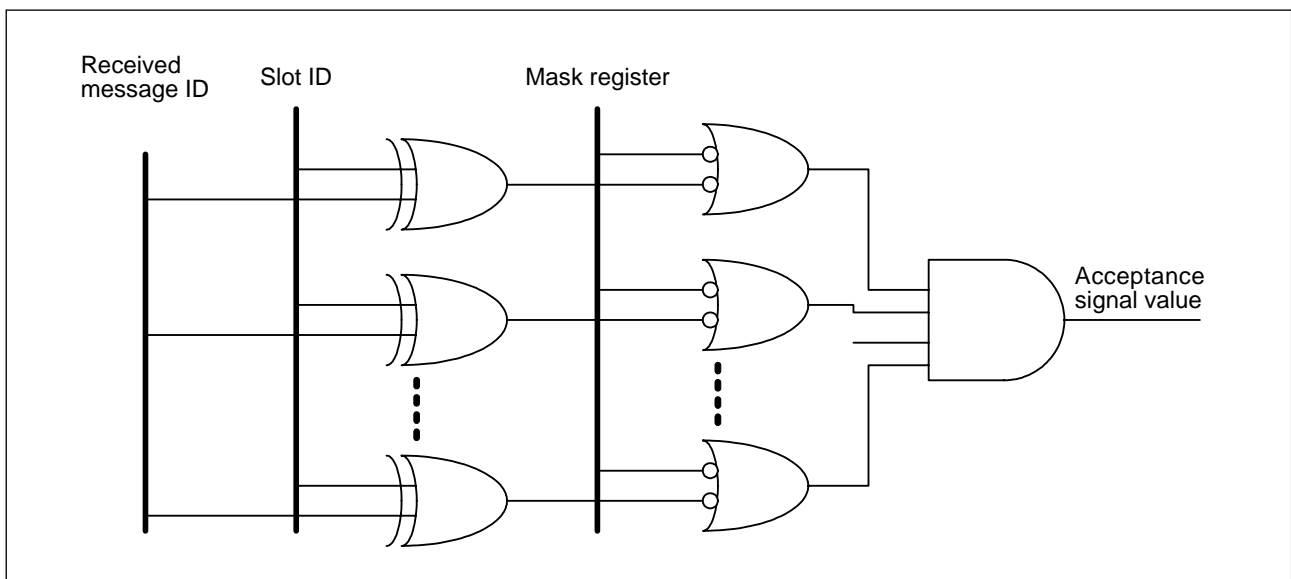

Slot ID	Set the value of the message ID to receive.
Mask register	0: Ignores the corresponding bit of the received message ID. 1: Compares the corresponding bit of the received message ID and the corresponding bit of the slot ID.
Acceptance value	0: Discards the message. 1: Receives the message.

Figure 31 Structure of ID and the mask register

b7	b6	b5	b4	b3	b2	b1	b0	CAN0	CAN1	
			SID10	SID9	SID8	SID7	SID6	0160 ₁₆	0360 ₁₆	C0GMR C1GMR
		SID5	SID4	SID3	SID2	SID1	SID0	0161 ₁₆	0361 ₁₆	
				EID17	EID16	EID15	EID14	0162 ₁₆	0362 ₁₆	
EID13	EID12	EID11	EID10	EID9	EID8	EID7	EID6	0163 ₁₆	0363 ₁₆	
		EID5	EID4	EID3	EID2	EID1	EID0	0164 ₁₆	0364 ₁₆	
			SID10	SID9	SID8	SID7	SID6	0166 ₁₆	0366 ₁₆	COLMAR C1LMAR
		SID5	SID4	SID3	SID2	SID1	SID0	0167 ₁₆	0367 ₁₆	
				EID17	EID16	EID15	EID14	0168 ₁₆	0368 ₁₆	
EID13	EID12	EID11	EID10	EID9	EID8	EID7	EID6	0169 ₁₆	0369 ₁₆	
		EID5	EID4	EID3	EID2	EID1	EID0	016A ₁₆	036A ₁₆	
			SID10	SID9	SID8	SID7	SID6	016C ₁₆	036C ₁₆	COLMBR C1LMBR
		SID5	SID4	SID3	SID2	SID1	SID0	016D ₁₆	036D ₁₆	
				EID17	EID16	EID15	EID14	016E ₁₆	036E ₁₆	
EID13	EID12	EID11	EID10	EID9	EID8	EID7	EID6	016F ₁₆	036F ₁₆	
		EID5	EID4	EID3	EID2	EID1	EID0	0170 ₁₆	0370 ₁₆	

Figure 32 Memory map and bit assignment at byte access^{*2}

b15	b14	b13	b12	b11	b10	b9	b8	b7	b6	b5	b4	b3	b2	b1	b0	CAN0	CAN1	
			SID10	SID9	SID8	SID7	SID6			SID5	SID4	SID3	SID2	SID1	SID0	0160 ₁₆	0360 ₁₆	C0GMR C1GMR
				EID17	EID16	EID15	EID14	EID13	EID12	EID11	EID10	EID9	EID8	EID7	EID6	0162 ₁₆	0362 ₁₆	
		EID5	EID4	EID3	EID2	EID1	EID0									0164 ₁₆	0364 ₁₆	
			SID10	SID9	SID8	SID7	SID6			SID5	SID4	SID3	SID2	SID1	SID0	0166 ₁₆	0366 ₁₆	COLMAR C1LMAR
				EID17	EID16	EID15	EID14	EID13	EID12	EID11	EID10	EID9	EID8	EID7	EID6	0168 ₁₆	0368 ₁₆	
		EID5	EID4	EID3	EID2	EID1	EID0									016A ₁₆	036A ₁₆	
			SID10	SID9	SID8	SID7	SID6			SID5	SID4	SID3	SID2	SID1	SID0	016C ₁₆	036C ₁₆	COLMBR C1LMBR
				EID17	EID16	EID15	EID14	EID13	EID12	EID11	EID10	EID9	EID8	EID7	EID6	016E ₁₆	036E ₁₆	
		EID5	EID4	EID3	EID2	EID1	EID0									0170 ₁₆	0370 ₁₆	

Figure 33 Memory map and bit assignment at word access^{*3}

*1: The global mask register, local mask register A, and local mask register B in the 1N group microcomputers are located at the CAN1 addresses.

*2: The registers are accessed byte wise when the message order select bit in the CAN control register = 1.

*3: The registers are accessed word wise when the message order select bit in the CAN control register = 0.

(2) Examples for using the acceptance filter

- Usage example 1

Table 4 shows how each register should be set when slot 0 is to receive a standard data frame or standard remote frame with ID123₁₆.

Table 4 Acceptance filter usage example 1

		SID ₁₀₋₆	SID ₅₋₀	EID ₁₇₋₁₄	EID ₁₃₋₆	EID ₅₋₀
Slot 0		00100	100011	XXXX	XXXXXXXX	XXXXXX
Mask register	COGMR	11111	111111	XXXX	XXXXXXXX	XXXXXX
Receive message	ID123 ₁₆	00100	100011			

- Usage example 2

Table 5 shows how each register should be set when slot 0 is to receive two standard data frames or standard remote frames with ID122₁₆ and ID123₁₆.

Table 5 Acceptance filter usage example 2

		SID ₁₀₋₆	SID ₅₋₀	EID ₁₇₋₁₄	EID ₁₃₋₆	EID ₅₋₀
Slot 0		00100	10001X	XXXX	XXXXXXXX	XXXXXX
Mask register	COGMR	11111	111110	XXXX	XXXXXXXX	XXXXXX
Receive message	ID122 ₁₆	00100	100010			
	ID123 ₁₆	00100	100011			

- Usage example 3

Table 6 shows how each register should be set when slot 0 is to receive an extended data frame or extended remote frame with ID12345678₁₆.

Table 6 Acceptance filter usage example 3

		SID ₁₀₋₆	SID ₅₋₀	EID ₁₇₋₁₄	EID ₁₃₋₆	EID ₅₋₀
Slot 0		10010	001101	0001	01011001	111000
Mask register	COGMR	11111	111111	1111	11111111	111111
Receive message	ID12345678 ₁₆	10010	001101	0001	01011001	111000

6.2 Acceptance Filter Support Unit (ASU)

The acceptance filter support unit is a function to determine whether the received ID is valid or not by means of a table search. To use this function, first register the ID to receive in the data table. Next, store the received ID in the CAN acceptance filter support register, read out the decoded received ID from the CAN acceptance filter support register, and check it by searching the table. The acceptance filter support unit can only be used for the IDs of standard frames.

The acceptance filter support unit will prove effective in the following cases:

- When the IDs to receive cannot be masked by the acceptance filter (Example: IDs to receive = 078_{16} , 087_{16} , 111_{16})
- When there are too many IDs to receive and filtering in software requires an excessive amount of time

6.2.1 Using the Acceptance Filter Support Unit

The following shows how to use the acceptance filter support unit when the IDs to receive are 000_{16} , $00D_{16}$, $6F3_{16}$, $6F4_{16}$, and $6FF_{16}$.

(1) Setting up the data table

In ROM or RAM, prepare a data table in which the IDs to receive are registered. The data table can be located at any desired address.

The data table should be comprised of the bits representing each ID to receive by arranging the value representing the 8 high-order bits (SID_{10-3}) in the vertical axis and the value representing the 3 low-order bits (SID_{2-0}) that has been decoded into 8-bit quantity in the horizontal axis, with the corresponding bits set to 1 and all other bits set to 0.

(2) Writing to the CAN acceptance filter support register

If a message is received by CAN0, write the received ID to the CAN0 acceptance filter support register; if received by CAN1, write the received ID to the CAN1 acceptance filter support register.

(3) Reading out of the CAN acceptance filter support register

Read the value representing the 8 high-order bits (SID_{10-3}) of the received ID and the value representing the 3 low-order bits that has been decoded into 8-bit quantity out of the CAN acceptance filter support register.

(4) Determining the validity of the received ID

Search the data table set in (1) for the value that compares equal to the value read out of the CAN acceptance filter support register in (3) to determine whether the received ID is valid.

Figure 34 shows the structure of the CAN acceptance filter support register. Figure 35 shows the structure of the data table. Figure 36 shows the content of the CAN acceptance filter support register when written to and read out.

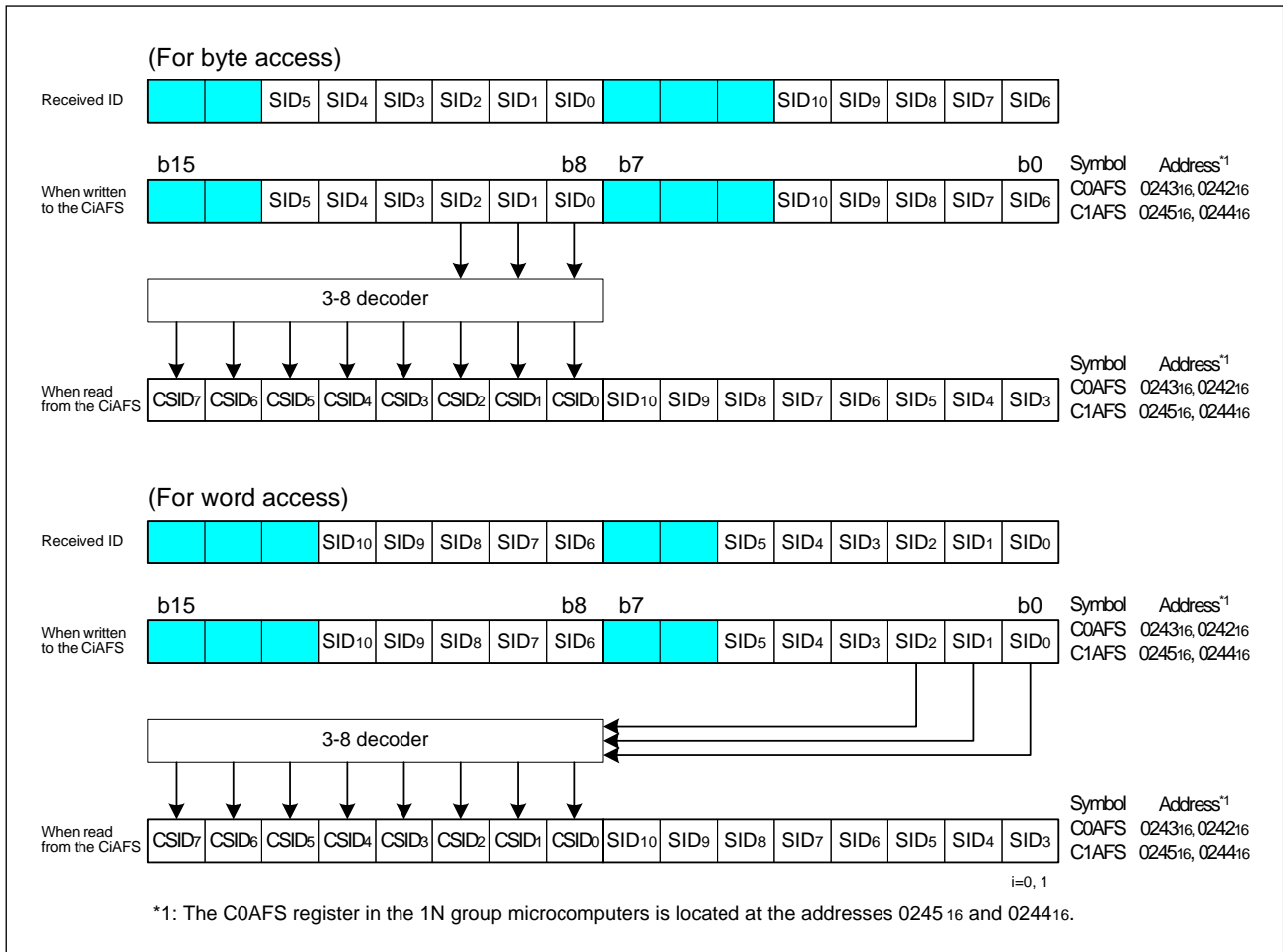

Figure 36 Content of the CAN acceptance filter support register when written to and read out

Figure 37 shows the procedure for using the acceptance filter support unit. Here, the received ID is checked in a CAN successful reception interrupt routine to see if it is valid or not.

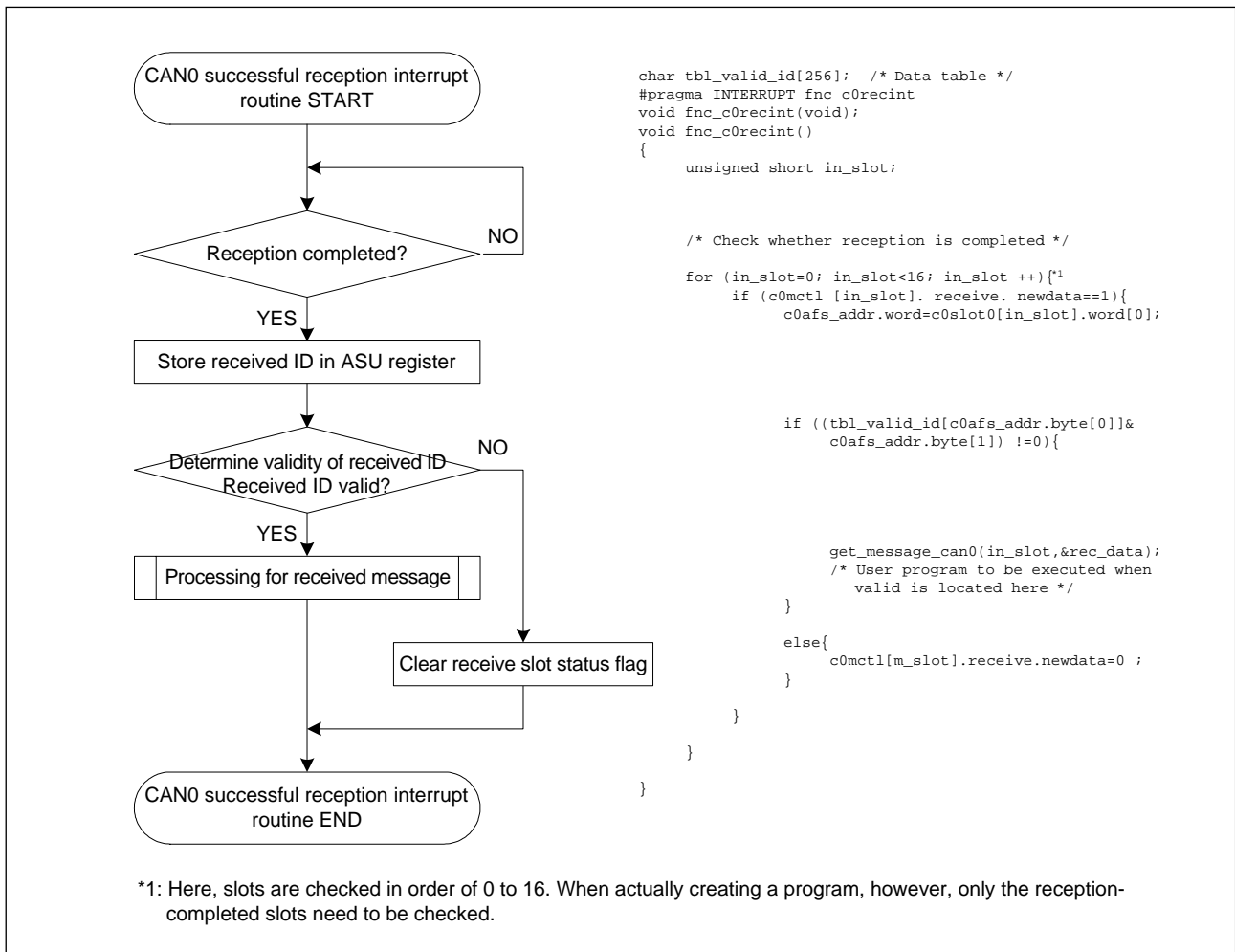

Figure 37 Procedure for using the acceptance filter support unit

7. CAN Sleep and CAN Wakeup Operations

7.1 CAN Sleep Operation

When the CAN module is in sleep mode, the clock supplied to it is turned off. Therefore, the CAN module does not operate at all. When not using the CAN module, it is recommended that the CAN module be placed into sleep mode to reduce the amount of current consumed in the chip.

Before placing the CAN module into sleep mode, always be sure to reset it.

Figure 38 shows the procedure for placing the CAN module into sleep mode.

If while in this state the microcomputer is placed into wait or stop mode, the amount of current consumed in the chip can further be reduced.

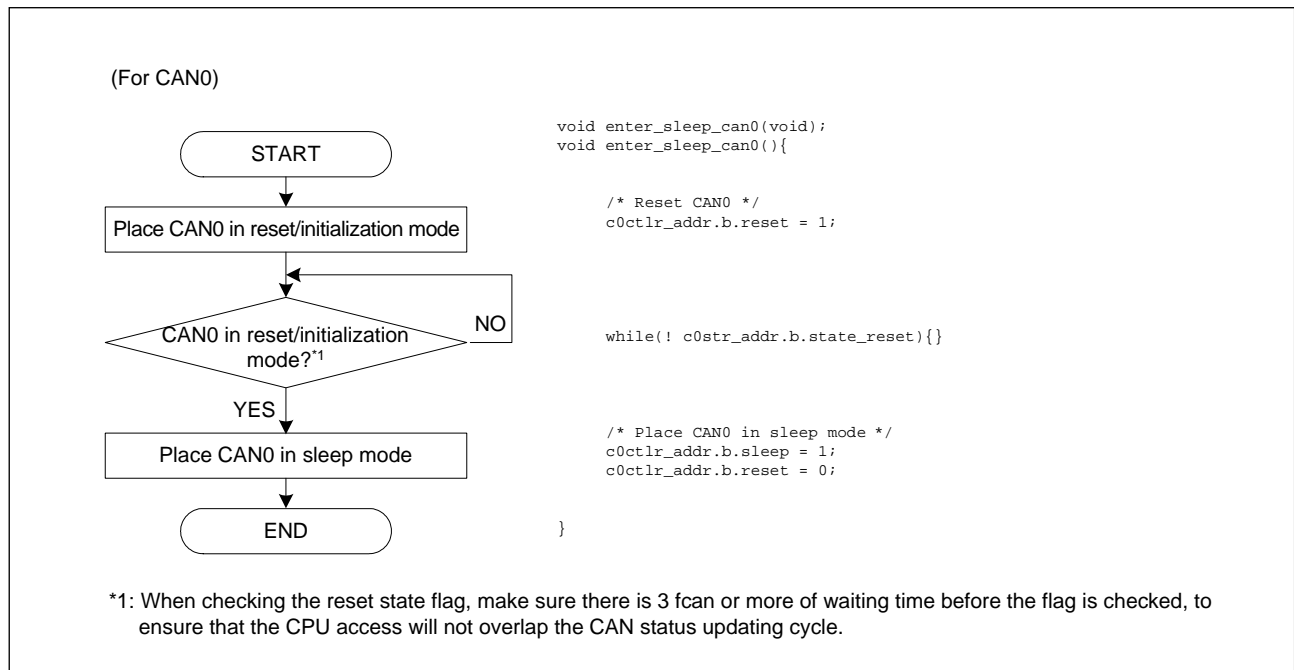

Figure 38 Procedure for placing the CAN module into sleep mode

7.2 CAN Wakeup Operation

While the CAN module is in sleep mode, it can be awoken from sleep mode by a CAN wakeup interrupt that is generated at the falling edge of the CAN receive line. CAN wakeup becomes usable by setting up the CAN wakeup interrupt control register to enable the interrupt.

The CAN wakeup interrupt is used for CAN0 and CAN1 in common. In the 6N4, 6NK, and 6NM groups, the CAN wakeup interrupt can be used for CAN0 and CAN1 individually by setting the IFSR02 bit in the interrupt request cause select register0 to 1. To use the CAN wakeup interrupt to reawaken the CAN module, perform CAN configuration in this interrupt routine.

Figure 39 shows the CAN wakeup procedure.

Here, the CAN modules of both CAN0 and CAN1 are reawakened from sleep mode in a CAN wakeup interrupt routine.

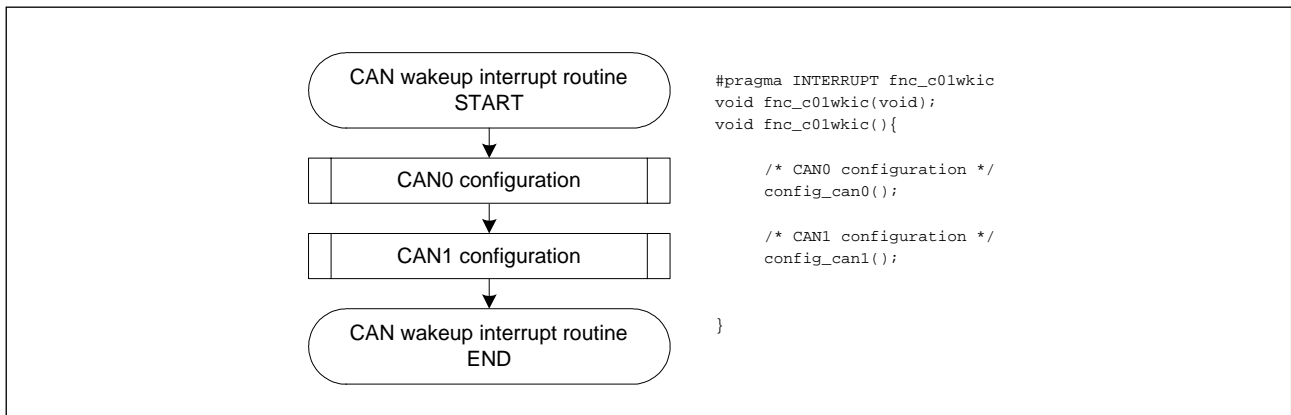

Figure 39 CAN wakeup procedure

8. Precautions Regarding the Sample Program

8.1 Symbol Notation of Each Register

The symbols representing each register in the sample program of this application note are based on the notation of Renesas standard C language SFR header files.

8.2 while Infinite Loop

To simplify the notation, some parts in the sample program are looped by a while statement. When actually creating a program, put a limit time on each while loop in order to enable the program to exit the loop when the time is over.

Figure 40 shows an example processing where a limit time is placed on a while loop.

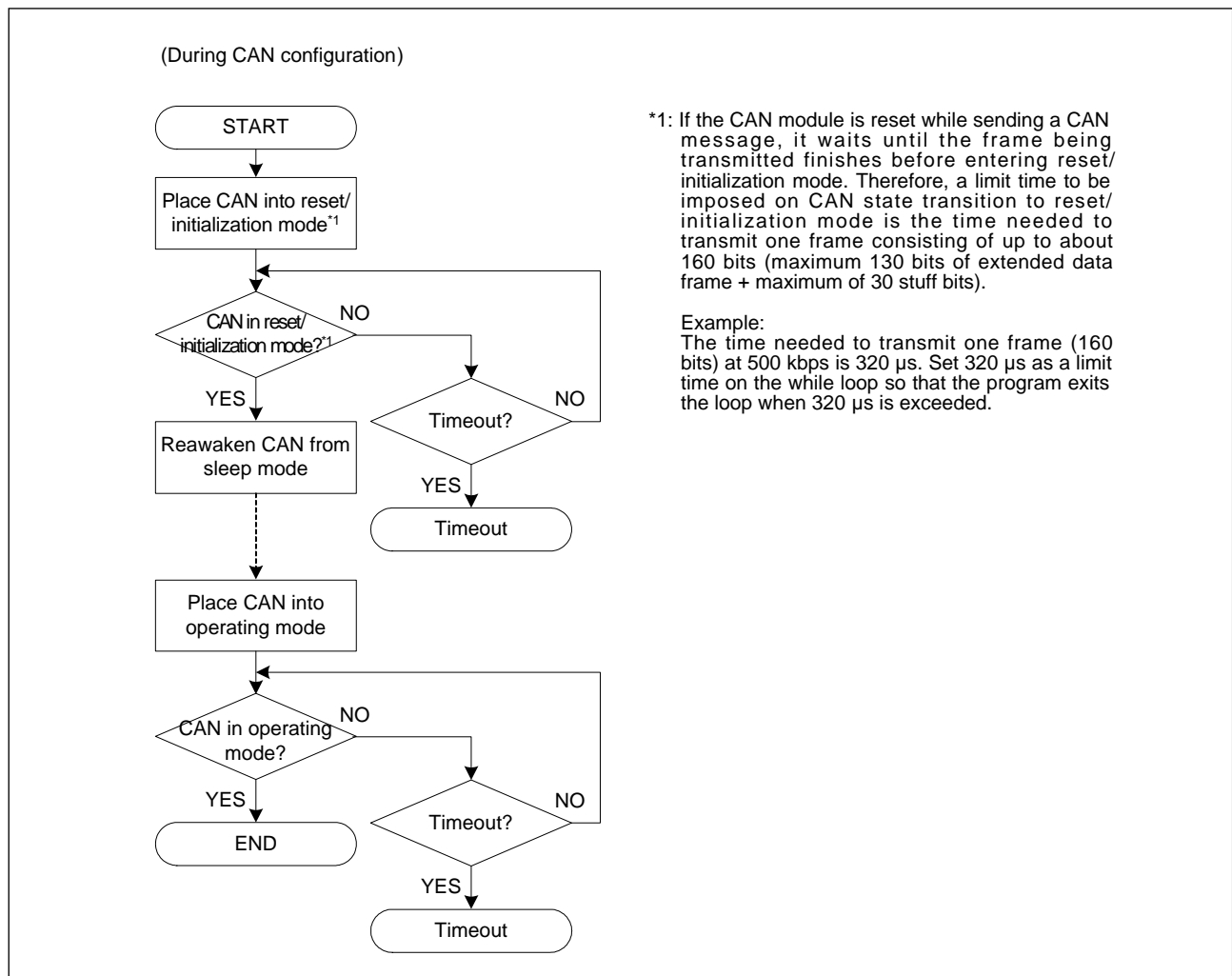

Figure 40 Example processing where a limit time is placed on a while loop

9. Web Site and Support Center

Renesas Technology Web Site

<http://www.renesas.com>

Where to contact for technical inquiries about CAN microcomputers

Customer Support Center: csc@renesas.com

DEVISION HISTORY	M16C/6N, M16C/1N, M16C/29, and R8C/22,23 Groups CAN Application Note
------------------	---

Rev.	Date	Description	
		Page	Summary
1.00	Nov 05, 2003	–	Unused version
2.00	Jul 05, 2004	–	First edition issued
2.01	Jul 28, 2004	1	The M16C/6NK, 6NL, 6NM, and 6NN groups were added to the application
		7	Tabled 1 was revised
		28	Figure 20 was revised
		44	Figure 34 *1 and 35 were revised
		45	Figure 36 was revised
		47	7.2 CAN Wakeup Operation was revised
2.02	Jun 08.2005	18	Figure 13 was revised
		19	Figure 14 was revised
		26	Figure 19 was revised
3.00	Oct.26.2005	1	The R8C/22,23 groups were added to the application

Keep safety first in your circuit designs!

1. Renesas Technology Corporation puts the maximum effort into making semiconductor products better and more reliable, but there is always the possibility that trouble may occur with them. Trouble with semiconductors may lead to personal injury, fire or property damage. Remember to give due consideration to safety when making your circuit designs, with appropriate measures such as (i) placement of substitutive, auxiliary circuits, (ii) use of nonflammable material or (iii) prevention against any malfunction or mishap.

Notes regarding these materials

1. These materials are intended as a reference to assist our customers in the selection of the Renesas Technology Corporation product best suited to the customer's application; they do not convey any license under any intellectual property rights, or any other rights, belonging to Renesas Technology Corporation or a third party.
2. Renesas Technology Corporation assumes no responsibility for any damage, or infringement of any third-party's rights, originating in the use of any product data, diagrams, charts, programs, algorithms, or circuit application examples contained in these materials.
3. All information contained in these materials, including product data, diagrams, charts, programs and algorithms represents information on products at the time of publication of these materials, and are subject to change by Renesas Technology Corporation without notice due to product improvements or other reasons. It is therefore recommended that customers contact Renesas Technology Corporation or an authorized Renesas Technology Corporation product distributor for the latest product information before purchasing a product listed herein.
The information described here may contain technical inaccuracies or typographical errors. Renesas Technology Corporation assumes no responsibility for any damage, liability, or other loss arising from these inaccuracies or errors.
Please also pay attention to information published by Renesas Technology Corporation by various means, including the Renesas Technology Corporation Semiconductor home page (<http://www.renesas.com>).
4. When using any or all of the information contained in these materials, including product data, diagrams, charts, programs, and algorithms, please be sure to evaluate all information as a total system before making a final decision on the applicability of the information and products. Renesas Technology Corporation assumes no responsibility for any damage, liability or other loss resulting from the information contained herein.
5. Renesas Technology Corporation semiconductors are not designed or manufactured for use in a device or system that is used under circumstances in which human life is potentially at stake. Please contact Renesas Technology Corporation or an authorized Renesas Technology Corporation product distributor when considering the use of a product contained herein for any specific purposes, such as apparatus or systems for transportation, vehicular, medical, aerospace, nuclear, or undersea repeater use.
6. The prior written approval of Renesas Technology Corporation is necessary to reprint or reproduce in whole or in part these materials.
7. If these products or technologies are subject to the Japanese export control restrictions, they must be exported under a license from the Japanese government and cannot be imported into a country other than the approved destination.
Any diversion or reexport contrary to the export control laws and regulations of Japan and/or the country of destination is prohibited.
8. Please contact Renesas Technology Corporation for further details on these materials or the products contained therein.