

To our customers,

---

## Old Company Name in Catalogs and Other Documents

---

On April 1<sup>st</sup>, 2010, NEC Electronics Corporation merged with Renesas Technology Corporation, and Renesas Electronics Corporation took over all the business of both companies. Therefore, although the old company name remains in this document, it is a valid Renesas Electronics document. We appreciate your understanding.

Renesas Electronics website: <http://www.renesas.com>

April 1<sup>st</sup>, 2010  
Renesas Electronics Corporation

Issued by: Renesas Electronics Corporation (<http://www.renesas.com>)

Send any inquiries to <http://www.renesas.com/inquiry>.

## Notice

1. All information included in this document is current as of the date this document is issued. Such information, however, is subject to change without any prior notice. Before purchasing or using any Renesas Electronics products listed herein, please confirm the latest product information with a Renesas Electronics sales office. Also, please pay regular and careful attention to additional and different information to be disclosed by Renesas Electronics such as that disclosed through our website.
2. Renesas Electronics does not assume any liability for infringement of patents, copyrights, or other intellectual property rights of third parties by or arising from the use of Renesas Electronics products or technical information described in this document. No license, express, implied or otherwise, is granted hereby under any patents, copyrights or other intellectual property rights of Renesas Electronics or others.
3. You should not alter, modify, copy, or otherwise misappropriate any Renesas Electronics product, whether in whole or in part.
4. Descriptions of circuits, software and other related information in this document are provided only to illustrate the operation of semiconductor products and application examples. You are fully responsible for the incorporation of these circuits, software, and information in the design of your equipment. Renesas Electronics assumes no responsibility for any losses incurred by you or third parties arising from the use of these circuits, software, or information.
5. When exporting the products or technology described in this document, you should comply with the applicable export control laws and regulations and follow the procedures required by such laws and regulations. You should not use Renesas Electronics products or the technology described in this document for any purpose relating to military applications or use by the military, including but not limited to the development of weapons of mass destruction. Renesas Electronics products and technology may not be used for or incorporated into any products or systems whose manufacture, use, or sale is prohibited under any applicable domestic or foreign laws or regulations.
6. Renesas Electronics has used reasonable care in preparing the information included in this document, but Renesas Electronics does not warrant that such information is error free. Renesas Electronics assumes no liability whatsoever for any damages incurred by you resulting from errors in or omissions from the information included herein.
7. Renesas Electronics products are classified according to the following three quality grades: “Standard”, “High Quality”, and “Specific”. The recommended applications for each Renesas Electronics product depends on the product’s quality grade, as indicated below. You must check the quality grade of each Renesas Electronics product before using it in a particular application. You may not use any Renesas Electronics product for any application categorized as “Specific” without the prior written consent of Renesas Electronics. Further, you may not use any Renesas Electronics product for any application for which it is not intended without the prior written consent of Renesas Electronics. Renesas Electronics shall not be in any way liable for any damages or losses incurred by you or third parties arising from the use of any Renesas Electronics product for an application categorized as “Specific” or for which the product is not intended where you have failed to obtain the prior written consent of Renesas Electronics. The quality grade of each Renesas Electronics product is “Standard” unless otherwise expressly specified in a Renesas Electronics data sheets or data books, etc.
  - “Standard”: Computers; office equipment; communications equipment; test and measurement equipment; audio and visual equipment; home electronic appliances; machine tools; personal electronic equipment; and industrial robots.
  - “High Quality”: Transportation equipment (automobiles, trains, ships, etc.); traffic control systems; anti-disaster systems; anti-crime systems; safety equipment; and medical equipment not specifically designed for life support.
  - “Specific”: Aircraft; aerospace equipment; submersible repeaters; nuclear reactor control systems; medical equipment or systems for life support (e.g. artificial life support devices or systems), surgical implantations, or healthcare intervention (e.g. excision, etc.), and any other applications or purposes that pose a direct threat to human life.
8. You should use the Renesas Electronics products described in this document within the range specified by Renesas Electronics, especially with respect to the maximum rating, operating supply voltage range, movement power voltage range, heat radiation characteristics, installation and other product characteristics. Renesas Electronics shall have no liability for malfunctions or damages arising out of the use of Renesas Electronics products beyond such specified ranges.
9. Although Renesas Electronics endeavors to improve the quality and reliability of its products, semiconductor products have specific characteristics such as the occurrence of failure at a certain rate and malfunctions under certain use conditions. Further, Renesas Electronics products are not subject to radiation resistance design. Please be sure to implement safety measures to guard them against the possibility of physical injury, and injury or damage caused by fire in the event of the failure of a Renesas Electronics product, such as safety design for hardware and software including but not limited to redundancy, fire control and malfunction prevention, appropriate treatment for aging degradation or any other appropriate measures. Because the evaluation of microcomputer software alone is very difficult, please evaluate the safety of the final products or system manufactured by you.
10. Please contact a Renesas Electronics sales office for details as to environmental matters such as the environmental compatibility of each Renesas Electronics product. Please use Renesas Electronics products in compliance with all applicable laws and regulations that regulate the inclusion or use of controlled substances, including without limitation, the EU RoHS Directive. Renesas Electronics assumes no liability for damages or losses occurring as a result of your noncompliance with applicable laws and regulations.
11. This document may not be reproduced or duplicated, in any form, in whole or in part, without prior written consent of Renesas Electronics.
12. Please contact a Renesas Electronics sales office if you have any questions regarding the information contained in this document or Renesas Electronics products, or if you have any other inquiries.

(Note 1) “Renesas Electronics” as used in this document means Renesas Electronics Corporation and also includes its majority-owned subsidiaries.

(Note 2) “Renesas Electronics product(s)” means any product developed or manufactured by or for Renesas Electronics.

---

# M16C/62A Group

## External Buses

---

### 1. Abstract

The following article introduces external bus.

### 2. Introduction

The explanation of this issue is M16C/62A Group.

### 3. External Buses

#### 3.1 Overview of External Buses

Memory and I/O external expansion can be connected to microcomputer easily by using external buses. When memory expansion mode or microprocessor mode is selected for processor mode, some of the pins function as the address bus, the data bus, and as control signals and this makes the external buses be able to operate.

When accessing an external area, 8-bit data bus width or 16-bit data bus width can be selected, based on the BYTE pin level. 16-bit width is used to access an internal area, regardless of the level of the BYTE pin. Fix the BYTE pin either to "H" or "L" level. 8-bit and 16-bit data bus widths cannot be used together in an external area.

### 3.2 Data Access

#### 3.2.1 Data Bus Width

If the voltage level input to the BYTE pin is "H", the external data bus width becomes 8 bits, and P10 (/D8) through P17 (/D15) can be used as I/O ports (Figure 3.2.1).

If the voltage level input to the BYTE pin is "L", the external data bus width becomes 16 bits, and P10 (/D8) through P17 (/D15) operate as a data bus (D8 through D15) (Figure 3.2.1).

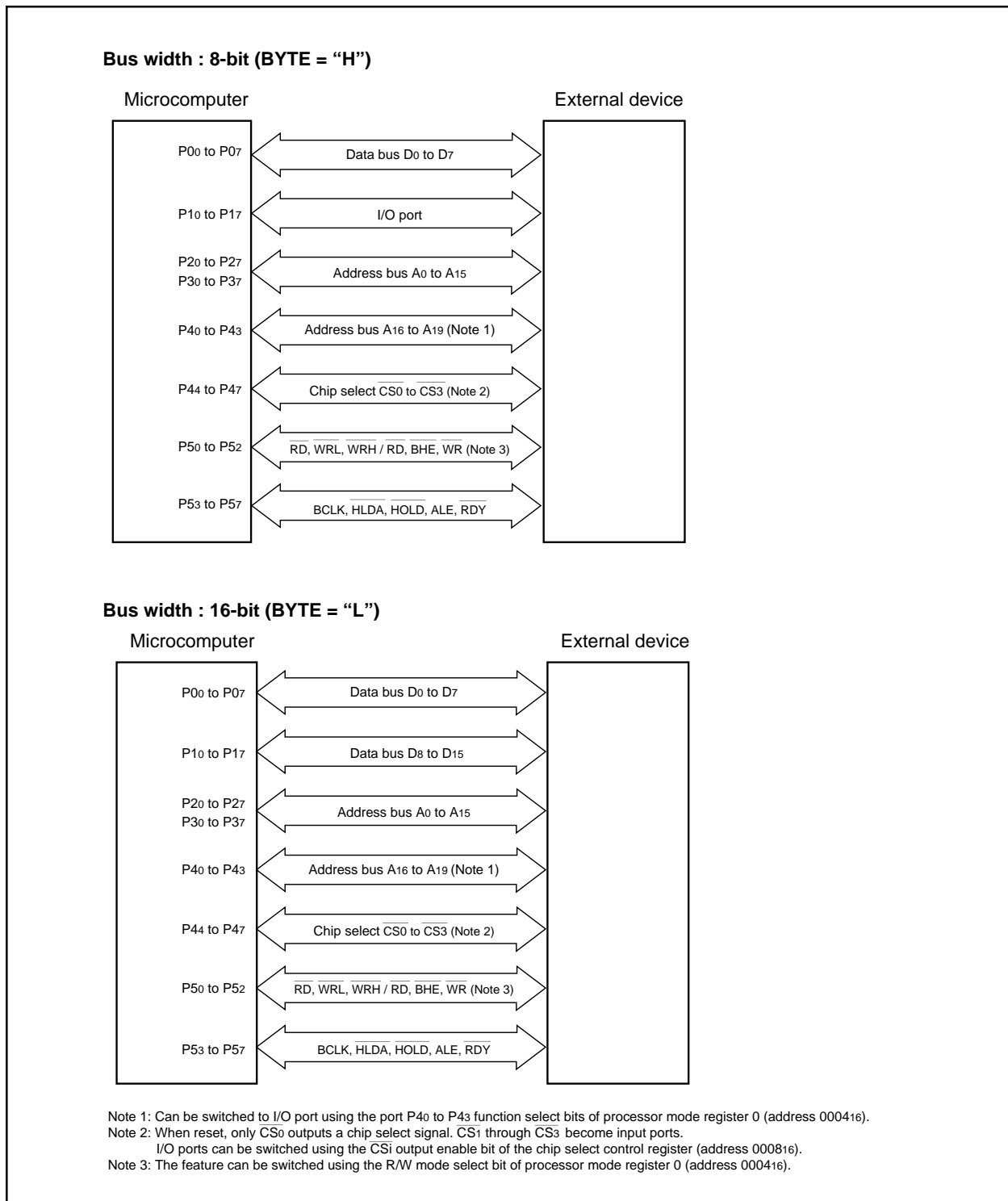

Figure 3.2.1. Level of BYTE pin and external data bus width

### 3.2.2 Chip Selects and Address Bus

Chip selects ( $P44/\overline{CS0}$  through  $P47/\overline{CS3}$ ) are output in areas resulting from dividing a 1-M byte memory space into four. To use the chip select, the chip select output must be enabled by setting the chip select control register. Figure 3.2.2 shows addresses in which chip selects become active (“L”). Since the extent of the internal area and the external area in memory expansion mode is different from those in microprocessor mode, there is a difference between areas for which  $\overline{CS0}$  is output. When an internal ROM/RAM area is being accessed, no chip select is output, and the address bus does not change (the address of the external area that was accessed previously is held).

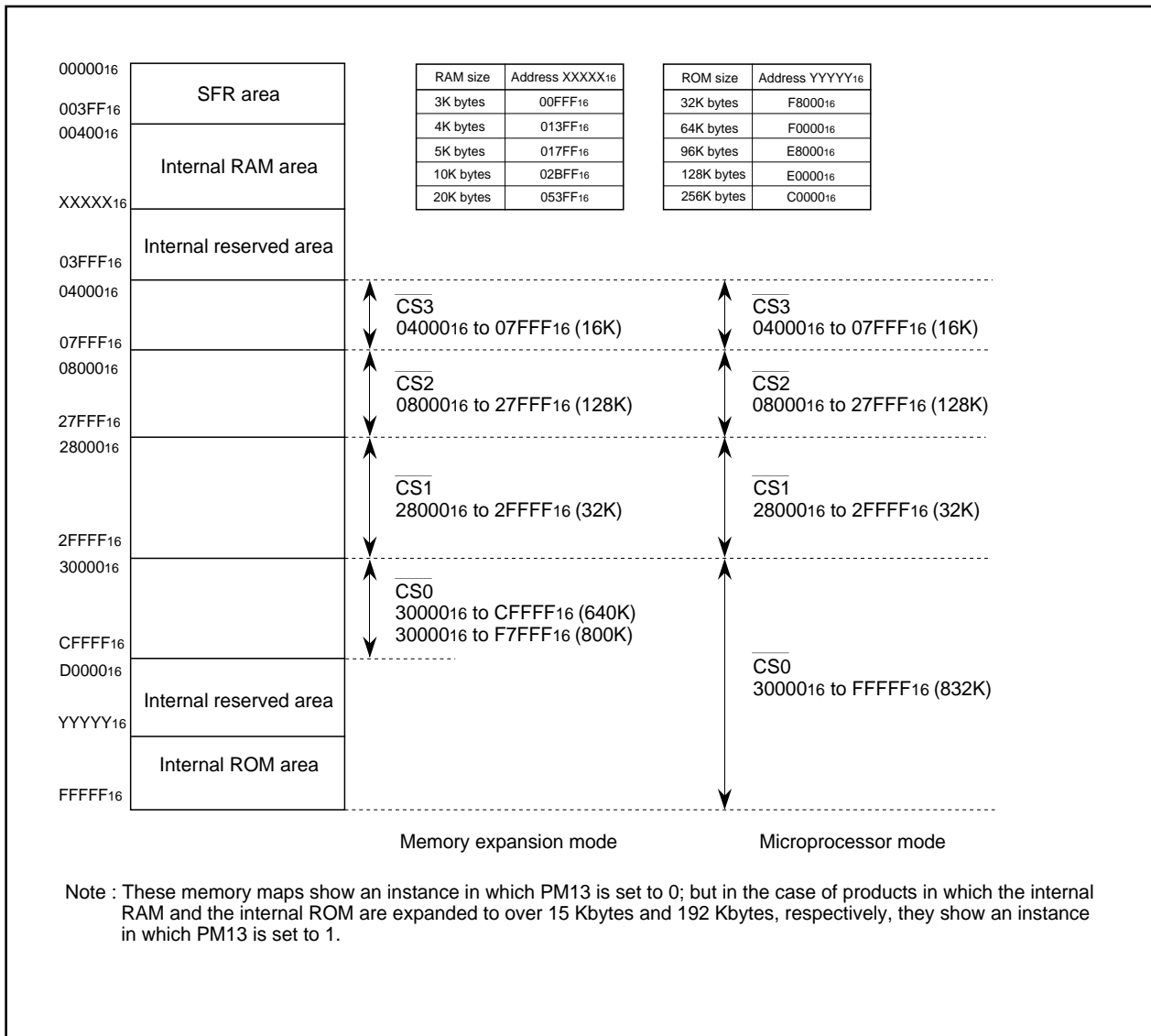

Figure 3.2.2. Addresses in which chip selects turn active (“L”)

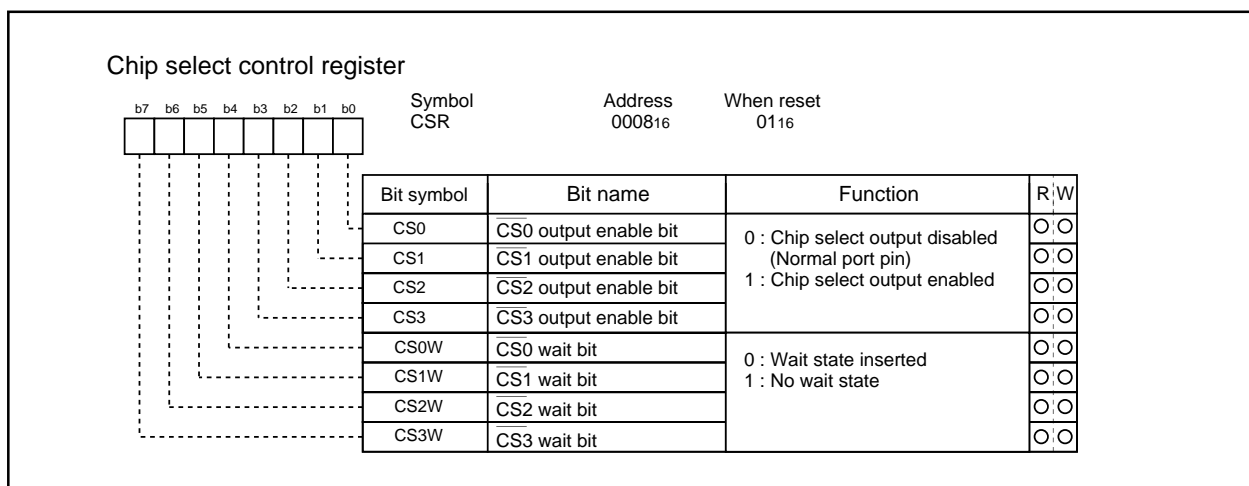

Figure 3.2.3. Chip select control register

### 3.2.3 Bus Types

The M16C/62A Group has two types of buses: a separate bus where separate pins are used for address output and data input/output and a multiplexed bus where pins are time- multiplexed and switched between address output and data input/output to save the number of pins used.

A separate bus is used to access devices such as ROM and RAM which have separate buses. The areas accessed via separate buses can be allocated for programs and data.

A multiplexed bus is used to access devices such as ASSPs which have multiplexed buses. The areas accessed via a multiplexed bus can only be allocated for data. Programs cannot be located in these areas.

The area accessed via a multiplex bus can be selected from three types of area  $\overline{CS2}$  area,  $\overline{CS1}$  area, and entire space by setting the multiplexed bus select bits (bits 4 and 5) of the processor mode register 0 (address 000416). However, the entire space cannot be selected when operating in the microprocessor mode.

Areas not accessed via multiplexed bus are accessed through separate buses.

When accessing an area set for access via a multiplexed bus the BYTE pin is "H" level, the data bus D0 to D7 is multiplexed with address bus A0 to A7.

If the BYTE pin is "L" level, the data bus D0 to D7 is multiplexed with address bus A1 to A8. In either case, the bus is switched between data and address separated only in time.

In the latter case, however, the addresses of connected devices are mapped into even addresses (every other addresses) of the M16C/62A. Therefore, be sure to access the M16C/62A's even addresses in length of bytes when accessing a connected device.

### 3.2.4 R/W Modes

The read/write signal that is output when accessing an external area can be selected between the  $\overline{RD}/\overline{BHE}/\overline{WR}$  and the  $\overline{RD}/\overline{WRH}/\overline{WRL}$  modes by setting the R/W mode select bit (bit 2) of the processor mode register 0 (address 000416). Use the  $\overline{RD}/\overline{BHE}/\overline{WR}$  mode to access a 16-bit wide RAM and the  $\overline{RD}/\overline{WRH}/\overline{WRL}$  mode to access an 8-bit wide RAM.

When the M16C/62A is reset, the  $\overline{RD}/\overline{BHE}/\overline{WR}$  mode is selected by default. To switch over the R/W mode, change the  $\overline{RD}/\overline{BHE}/\overline{WR}$  to the  $\overline{RD}/\overline{WRH}/\overline{WRL}$  mode before accessing an external RAM.

Refer to the connection examples of  $\overline{RD}/\overline{BHE}/\overline{WR}$  and  $\overline{RD}/\overline{WRH}/\overline{WRL}$  shown in Section 3.3, "Connection Examples."

### 3.3 Connection Examples

#### 3.3.1 16-bit Memory to 16-bit Width Data Bus Connection Example

Figure 3.3.1 shows an example of connecting M5M51016BTP (SRAM). In this diagram, when reset the microcomputer starts operating in single-chip mode. Change this mode to memory expansion mode in a program.

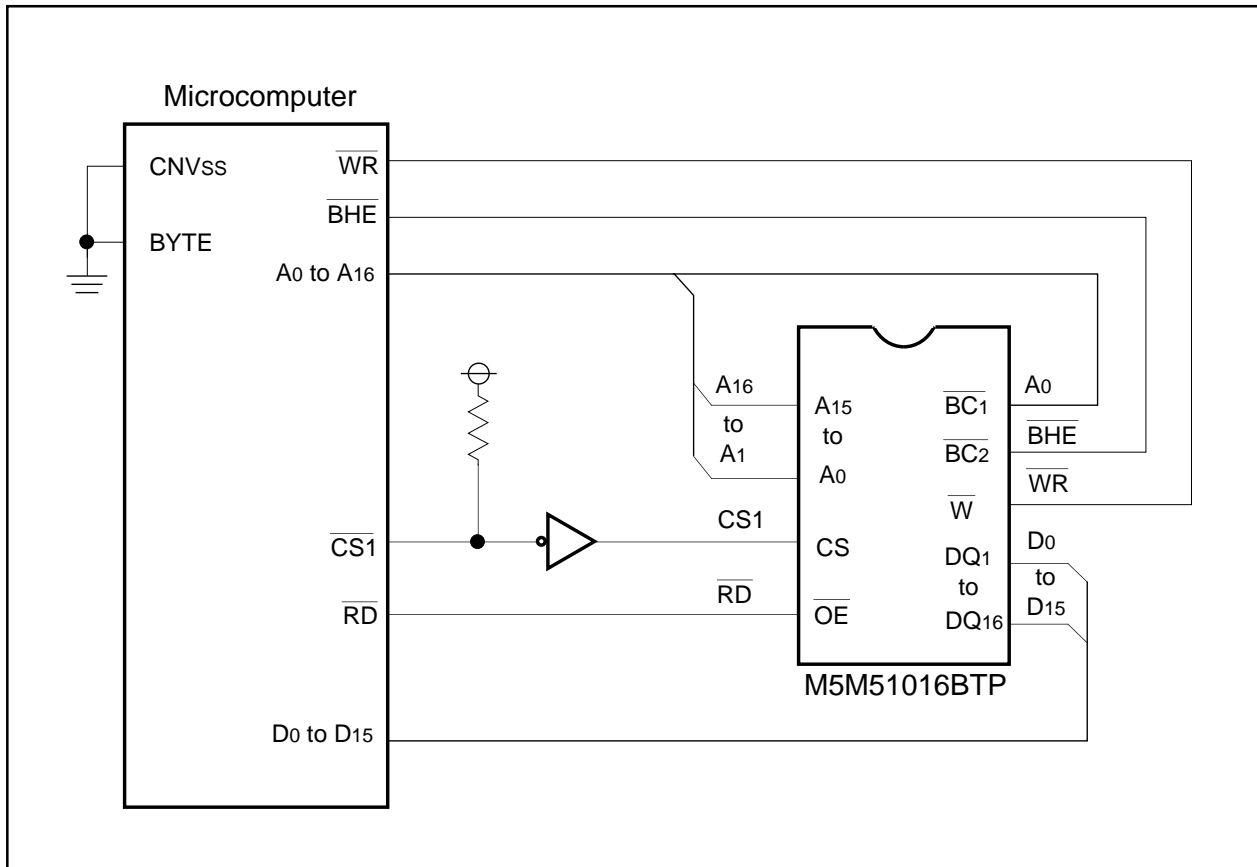

Figure 3.3.1. Example of connecting M5M51016BTP

### 3.3.2 8-bit Memory to 16-bit Width Data Bus Connection Example

Figure 3.3.2 shows an example of connecting two M5M5278's (SRAM) to a 16-bit data bus. In this diagram, when reset the microcomputer starts operating in single-chip mode. Change this mode to memory expansion mode in a program.

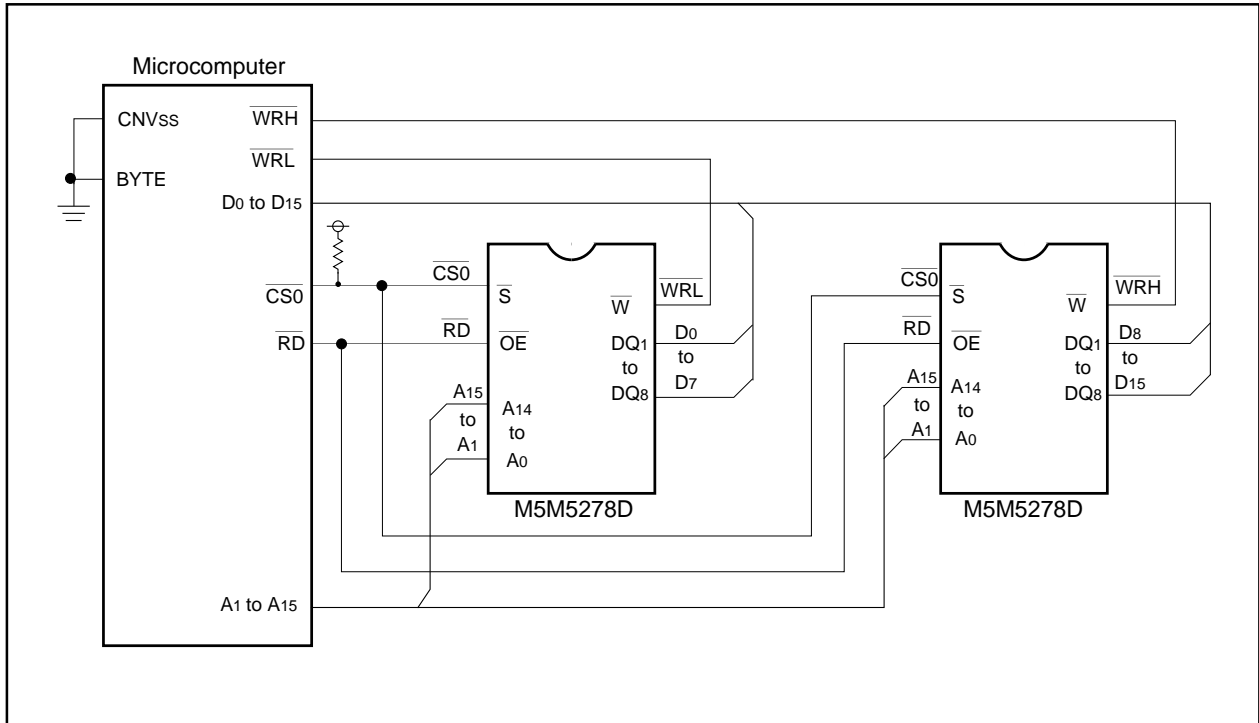

Figure 3.3.2. Example of connecting two M5M5278's to a 16-bit data bus

Figure 3.3.3 shows how to connect two Am29LV008B (flash memory). In 16-bit bus mode, the  $\overline{\text{BHE}}/\overline{\text{WRH}}$  pin functions as  $\overline{\text{BHE}}$ . When connecting 8-bit flash memory chips to the 16-bit bus, make sure the microcomputer's  $\overline{\text{WRL}}$  pin is connected to the  $\overline{\text{WR}}$  pins on both flash memory chips, and that data is written to the flash memory in units of 16 bits beginning with an even address.

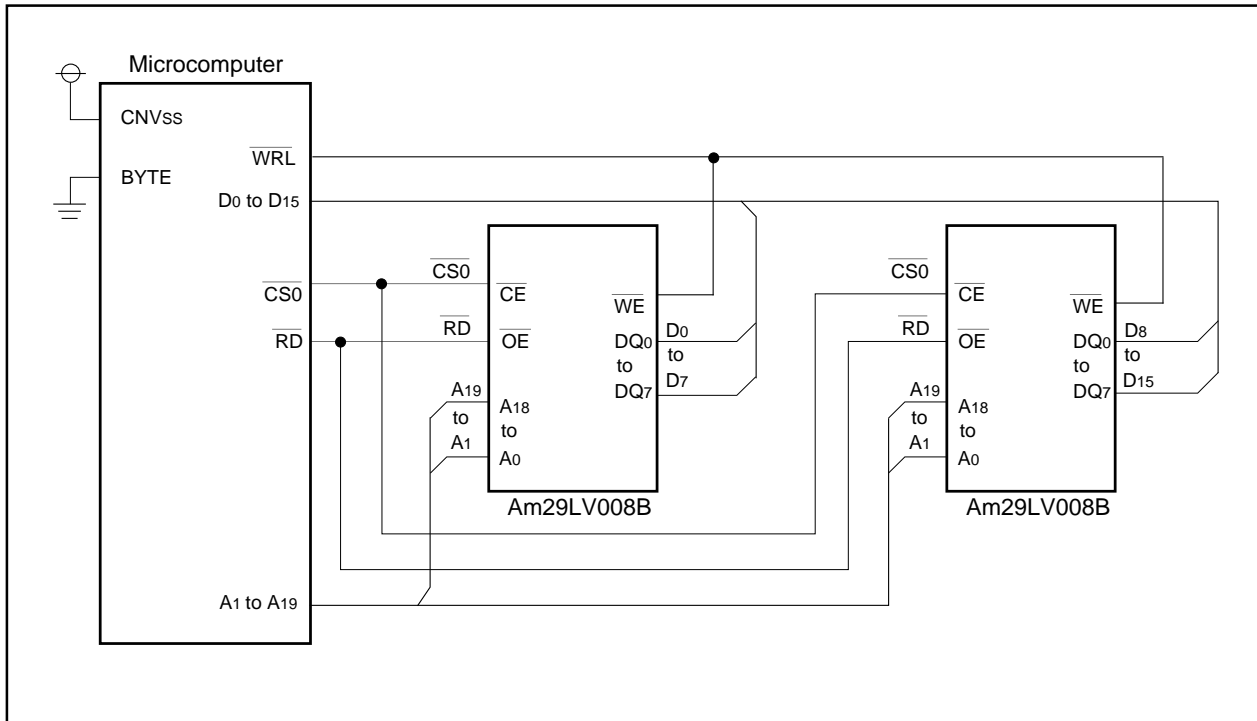

Figure 3.3.3. Example of connecting two Am29LV008B's to a 16-bit data bus

### 3.3.3 8-bit Memory to 8-bit Width Data Bus Connection Example

Figure 3.3.4 shows an example of connecting two M5M5278's (SRAM) to an 8-bit data bus. In this diagram, when reset the microcomputer starts operating in single-chip mode. Change this mode to memory expansion mode in a program.

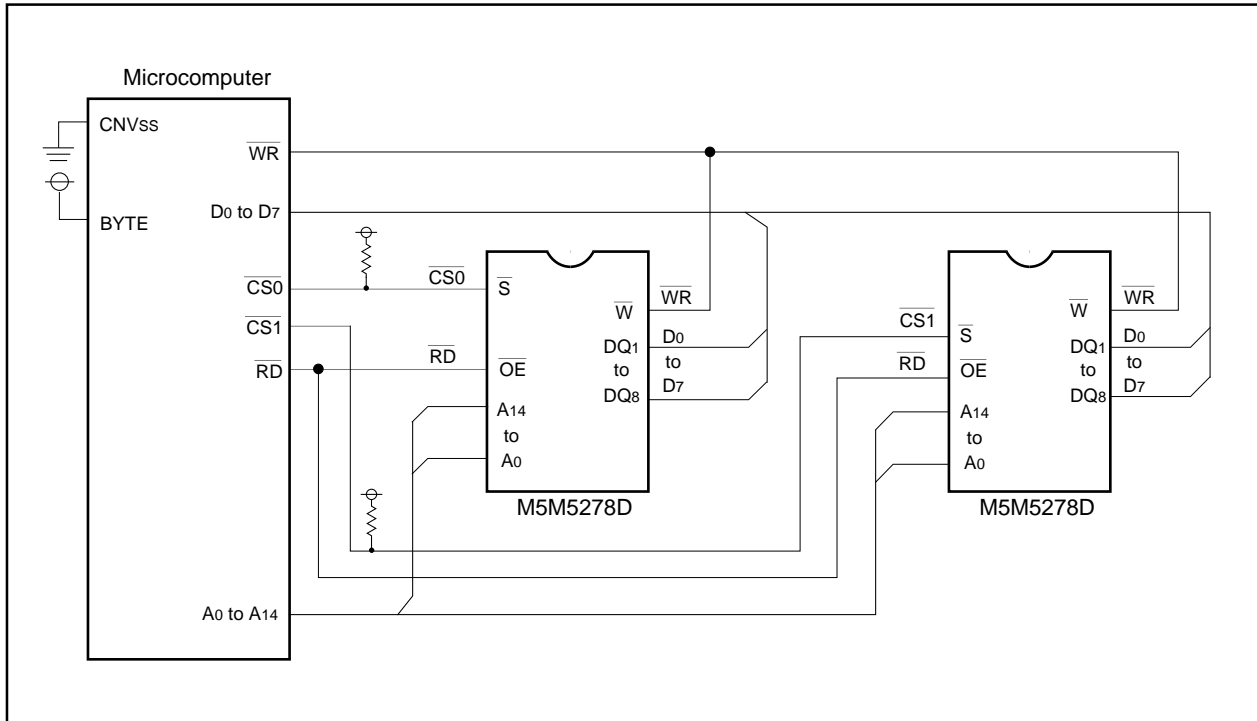

Figure 3.3.4. Example of connecting two M5M5278's to an 8-bit data bus

**3.3.4 Two 8-bit and 16-Bit Memory to 16-Bit Width Data Bus Connection Example**

Figure 3.3.5 shows an example of connecting M5M28F102 (16-bit flash memory) and two M5M5278's (8-bit SRAM) to a 16-bit data bus.

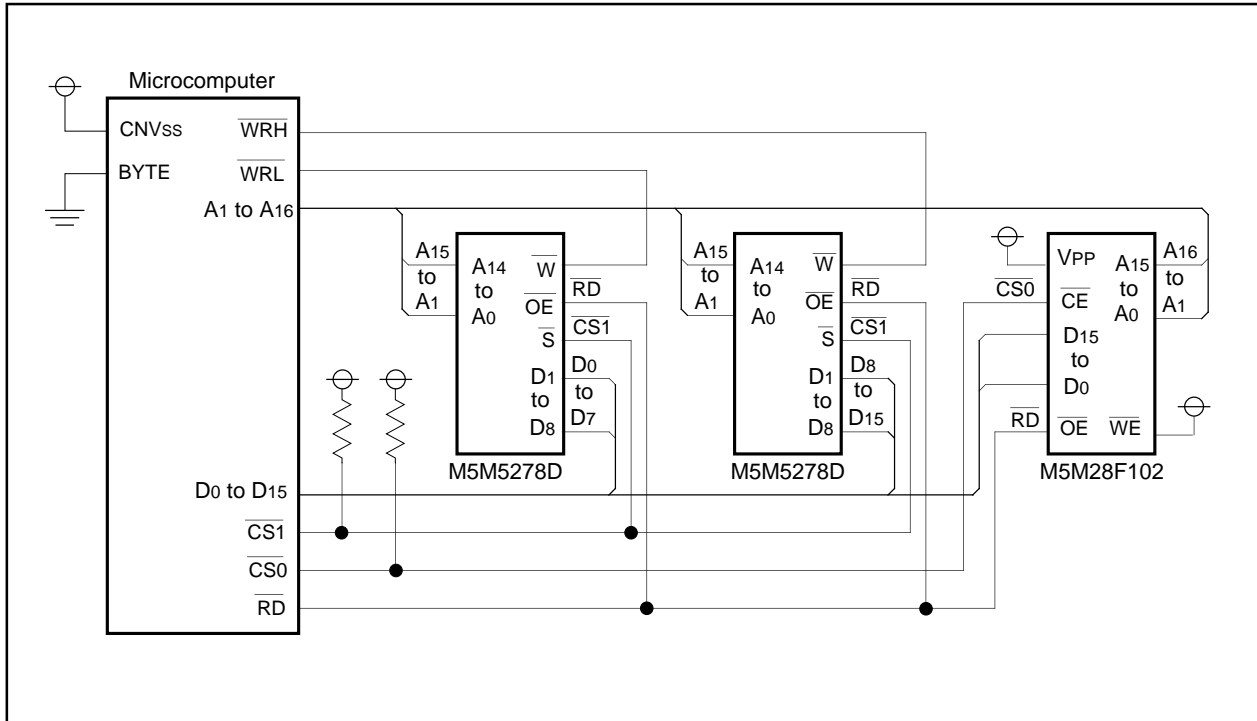

Figure 3.3.5. Example of connection of two 8-bit memories and one 16-bit memory to 16-bit width data bus

### 3.3.5 Chip Selects and Address Bus

When there are insufficient chip select signals, it is necessary to generate chip selects externally. Figure 3.3.6 shows an example of a connection in which the  $\overline{CS2}$  (128K bytes) area is divided into four 32K byte areas.

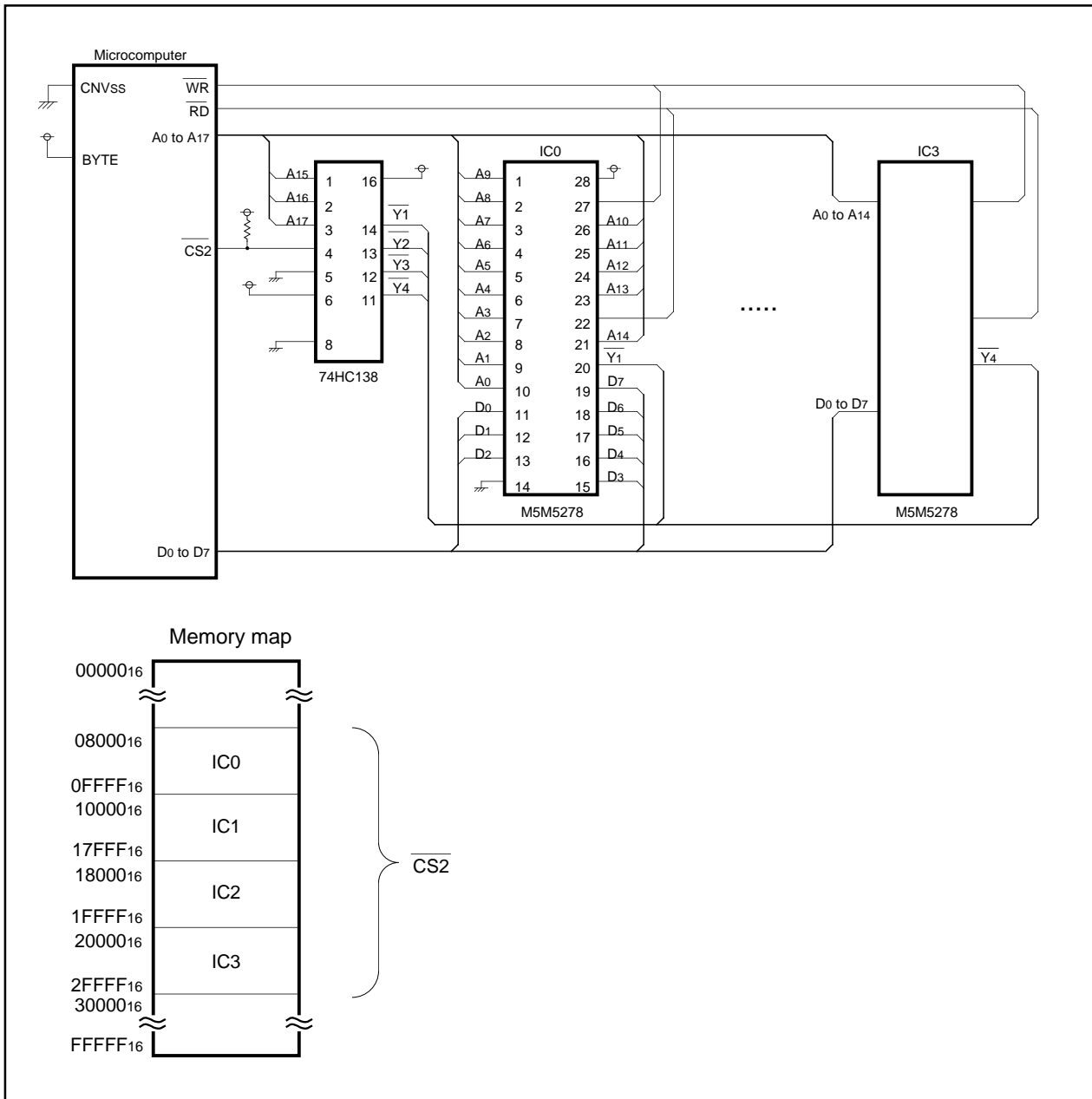

Figure 3.3.6. Chip selects and address bus

### 3.4 Connectable Memories

#### 3.4.1 Operation Frequency and Access Time

Connectable memories depend upon the BCLK frequency  $f(\text{BCLK})$ . The frequency of  $f(\text{BCLK})$  is equal to that of the BCLK, and is contingent on the oscillator's frequency and on the settings in the system clock select bits (bit 6 of address 000616, and bits 6 and 7 of address 000716).

The following are the conditional equations for the connections. Meet these conditions minimally. Figures 3.4.1 and 3.4.2 show the relation between the frequency of BCLK and memory.

##### (1) Read cycle time (tCR)/write cycle time (tCW)

Read cycle time (tCR) and write cycle time (tCW) must satisfy the following conditional expressions:

- **With the Wait option cleared**

$$t_{\text{CR}} < 10^9/f(\text{BCLK}) \text{ and } t_{\text{CW}} < 10^9/f(\text{BCLK})$$

- **With the Wait option selected**

$$t_{\text{CR}} < 2 \times 10^9/f(\text{BCLK}) \text{ and } t_{\text{CW}} < 2 \times 10^9/f(\text{BCLK})$$

##### (2) Address access time [ta(A)]

Address access time [ta(A)] must satisfy the following conditional expressions:

###### (a) Vcc = 5V

- **With the Wait option cleared**

$$t_{\text{a}}(\text{A}) < 10^9/f(\text{BCLK}) - 65(\text{ns})^*$$

- **With the Wait option selected**

$$t_{\text{a}}(\text{A}) < 2 \times 10^9/f(\text{BCLK}) - 65(\text{ns})^*$$

$$\begin{aligned} * 65(\text{ns}) &= t_{\text{d}}(\text{BCLK} - \text{AD}) + t_{\text{su}}(\text{DB} - \text{RD}) - t_{\text{h}}(\text{BCLK} - \text{RD}) \\ &= (\text{address output delay time}) + (\text{data input setup time}) - (\text{RD signal output hold time}) \end{aligned}$$

###### (b) Vcc = 3V

- **With the Wait option cleared**

$$t_{\text{a}}(\text{A}) < 10^9/f(\text{BCLK}) - 140(\text{ns})^*$$

- **With the Wait option selected**

$$t_{\text{a}}(\text{A}) < 2 \times 10^9/f(\text{BCLK}) - 140(\text{ns})^*$$

$$\begin{aligned} * 140(\text{ns}) &= t_{\text{d}}(\text{BCLK} - \text{AD}) + t_{\text{su}}(\text{DB} - \text{RD}) - t_{\text{h}}(\text{BCLK} - \text{RD}) \\ &= (\text{address output delay time}) + (\text{data input setup time}) - (\text{RD signal output hold time}) \end{aligned}$$

##### (3) Chip select access time [ta(S)]

Chip select access time [ta(S)] must satisfy the following conditional expressions:

###### (a) Vcc = 5V

- **With the Wait option cleared**

$$t_{\text{a}}(\text{S}) < 10^9/f(\text{BCLK}) - 65(\text{ns})^*$$

- **With the Wait option selected**

$$t_{\text{a}}(\text{S}) < 2 \times 10^9/f(\text{BCLK}) - 65(\text{ns})^*$$

$$\begin{aligned} * 65(\text{ns}) &= t_{\text{d}}(\text{BCLK} - \text{CS}) + t_{\text{su}}(\text{DB} - \text{RD}) - t_{\text{h}}(\text{BCLK} - \text{RD}) \\ &= (\text{chip select output delay time}) + (\text{data input setup time}) - (\text{RD signal output hold time}) \end{aligned}$$

**(b) Vcc = 3V**

- **With the Wait option cleared**

$$t_a(S) < 10^9/f(\text{BCLK}) - 140(\text{ns})^*$$

- **With the Wait option selected**

$$t_a(S) < 2 \times 10^9/f(\text{BCLK}) - 140(\text{ns})^*$$

$$\begin{aligned} * 140(\text{ns}) &= t_d(\text{BCLK} - \text{CS}) + t_{su}(\text{DB} - \text{RD}) - t_h(\text{BCLK} - \text{RD}) \\ &= (\text{chip select output delay time}) + (\text{data input setup time}) - (\text{RD signal output hold time}) \end{aligned}$$

**(4) Output enable time [ta(OE)]**

Output enable time [ta(OE)] must satisfy the following conditional expressions:

**(a) Vcc = 5V**

- **With the Wait option cleared**

$$t_a(\text{OE}) < 10^9/(f(\text{BCLK}) \times 2) - 45(\text{ns}) = t_{ac1}(\text{RD-DB})$$

- **With the Wait option selected**

$$t_a(\text{OE}) < 3 \times 10^9/(f(\text{BCLK}) \times 2) - 45(\text{ns}) = t_{ac2}(\text{RD-DB})$$

**(b) Vcc = 3V**

- **With the Wait option cleared**

$$t_a(\text{OE}) < 10^9/(f(\text{BCLK}) \times 2) - 90(\text{ns}) = t_{ac1}(\text{RD-DB})$$

- **With the Wait option selected**

$$t_a(\text{OE}) < 3 \times 10^9/(f(\text{BCLK}) \times 2) - 90(\text{ns}) = t_{ac2}(\text{RD-DB})$$

**(5) Data setup time [tsu(D)]**

Data setup time [tsu(D)] must satisfy the following conditional expressions:

**(a) Vcc = 5V**

- **With the Wait option cleared**

$$t_{su}(\text{D}) < 10^9/(f(\text{BCLK}) \times 2) - 40(\text{ns})^*$$

- **With the Wait option selected**

$$t_{su}(\text{D}) < 10^9/f(\text{BCLK}) - 40(\text{ns})^*$$

$$\begin{aligned} * 40(\text{ns}) &= t_d(\text{BCLK} - \text{DB}) - t_h(\text{BCLK} - \text{WR}) \\ &= (\text{data output delay time}) - (\text{WR signal output hold time}) \end{aligned}$$

**(b) Vcc = 3V**

- **With the Wait option cleared**

$$t_{su}(\text{D}) < 10^9/(f(\text{BCLK}) \times 2) - 80(\text{ns})^*$$

- **With the Wait option selected**

$$t_{su}(\text{D}) < 10^9/f(\text{BCLK}) - 80(\text{ns})^*$$

$$\begin{aligned} * 80(\text{ns}) &= t_d(\text{BCLK} - \text{DB}) - t_h(\text{BCLK} - \text{WR}) \\ &= (\text{data output delay time}) - (\text{WR signal output hold time}) \end{aligned}$$

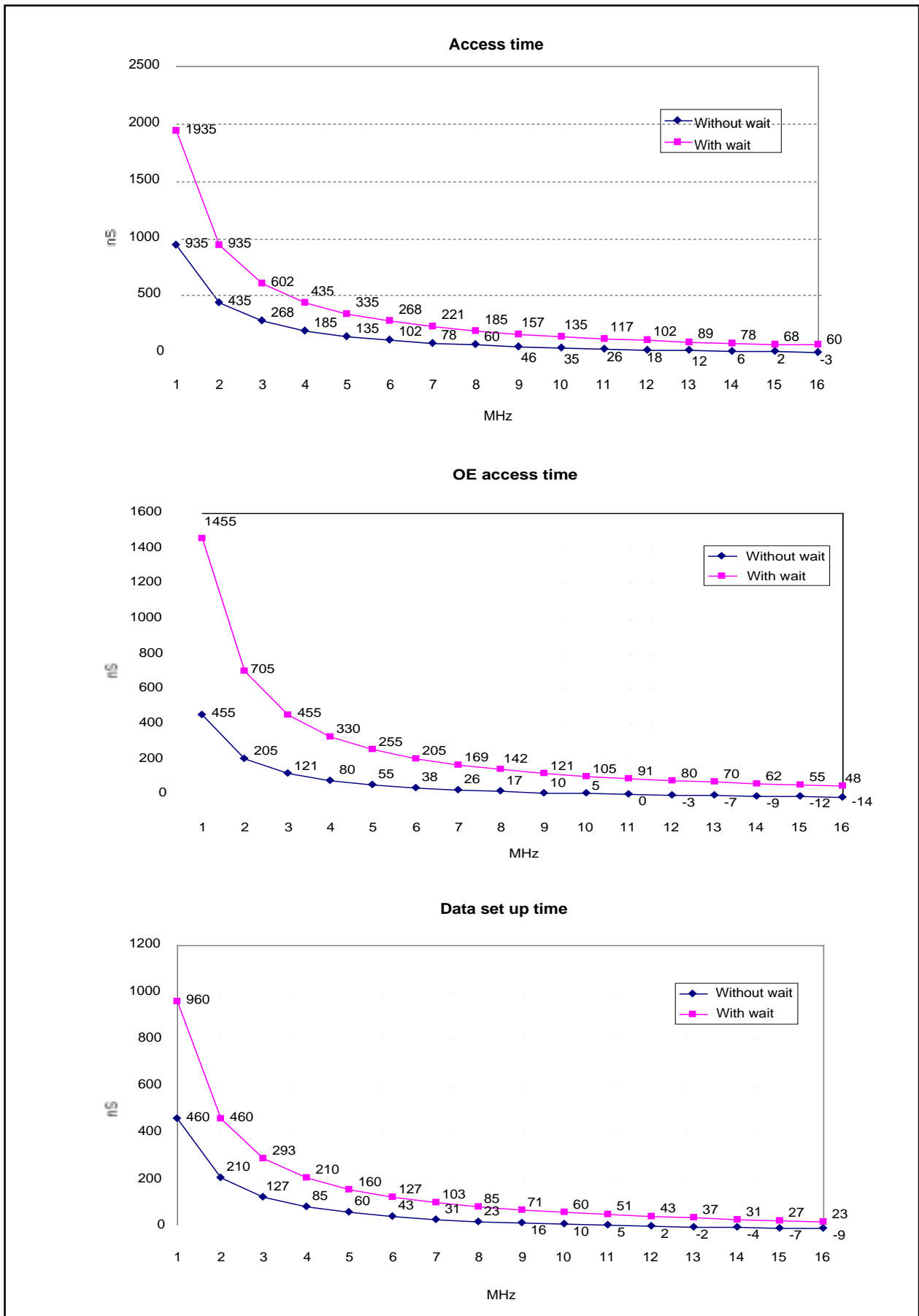

Figure 3.4.1. Relation between the frequency of BCLK and memory (Vcc = 5V)

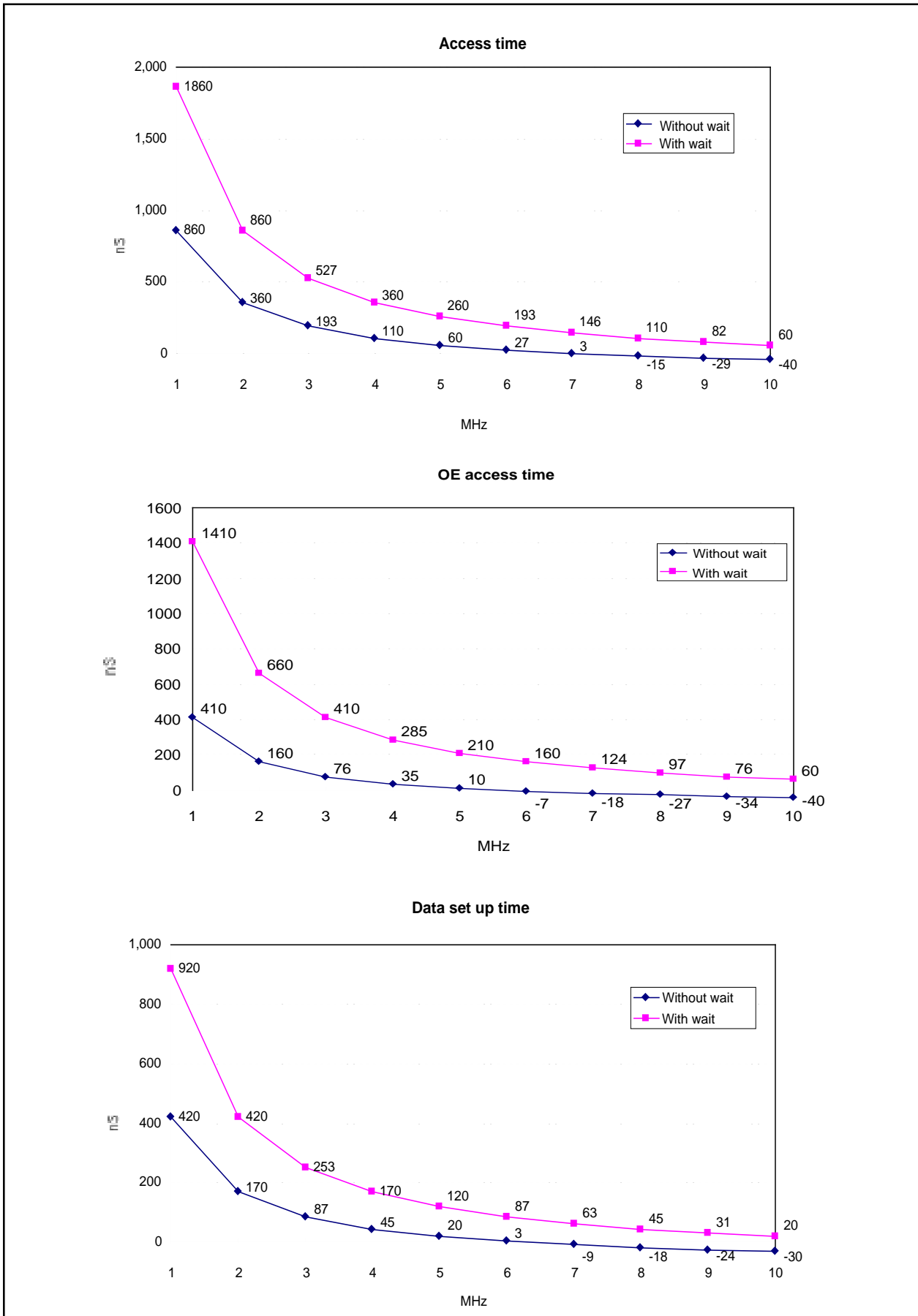

Figure 3.4.2. Relation between the frequency of BCLK and memory (Vcc = 3V)

### 3.4.2 Connecting Low-Speed Memory

To connect memory with long access time [ta(A)], either decrease the frequency of BCLK or set a software wait. Using the RDY feature allows you to connect memory having the timing that precludes connection though you set software wait.

#### (1) Using software wait

Set software wait by using either of bit 7 (PM17) of processor mode register 1 or bits 4 through 7 (CS0W through CS3W) of the chip select control register. With software wait set, if an address space is accessed in which a separate bus is selected, the bus cycle results in two cycles of BCLK; if an address space is accessed in which a multiplex bus is selected, the bus cycle results in three cycles of BCLK.

If bit 7 (PM17) of processor mode register 1 is set to "Wait selected", the microcomputer accesses every area with this option in effect. If bit 7 (PM17) of processor mode register 1 is set to "Wait cleared", the Wait option can be either selected or cleared, chip select by chip select, by setting bits 4 through 7 (CS0W through CS3W) of the chip select control register. Figures 3.4.3 through 3.4.5 show relation of processor mode and the wait bit (PM17, CSiW).

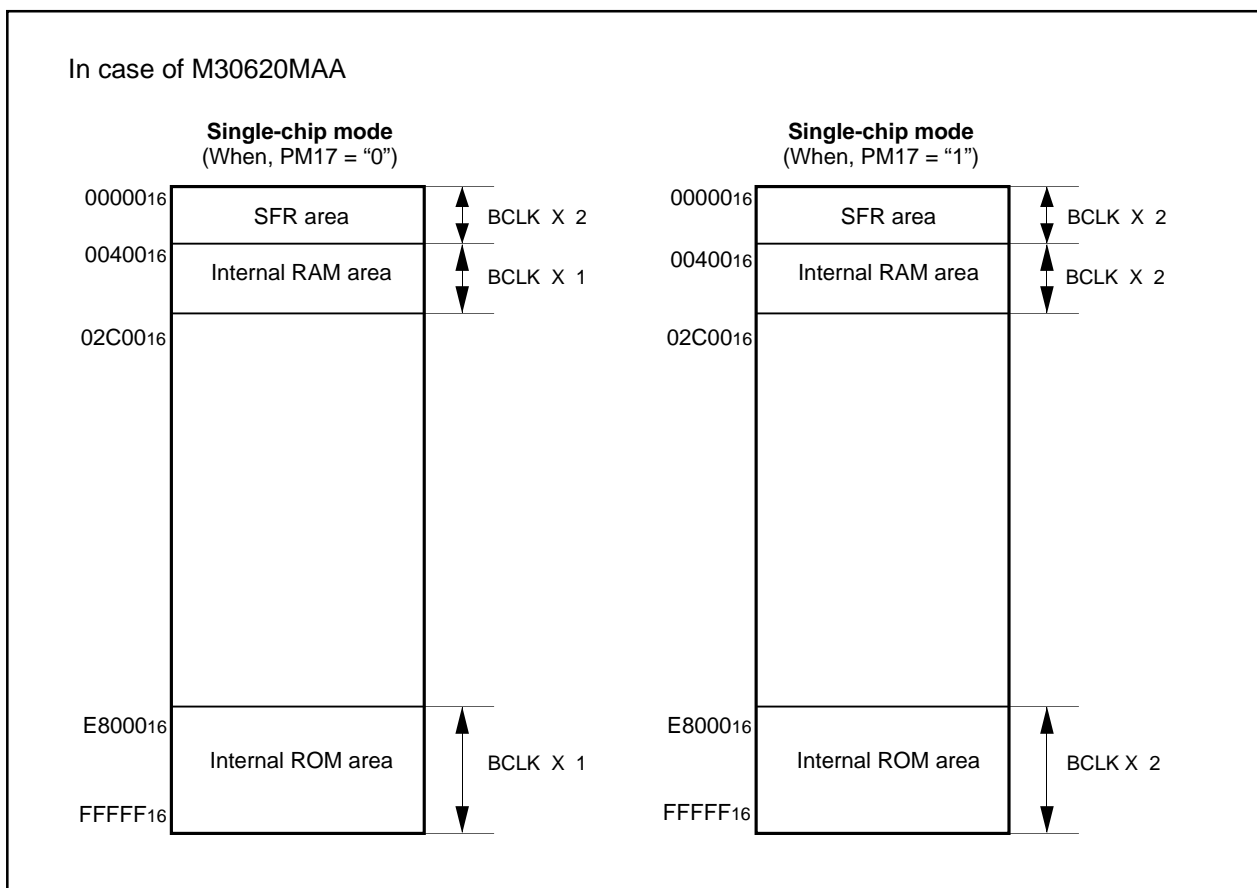

Figure 3.4.3. Relation of processor mode and the wait bit (PM17, CSiW) (1)

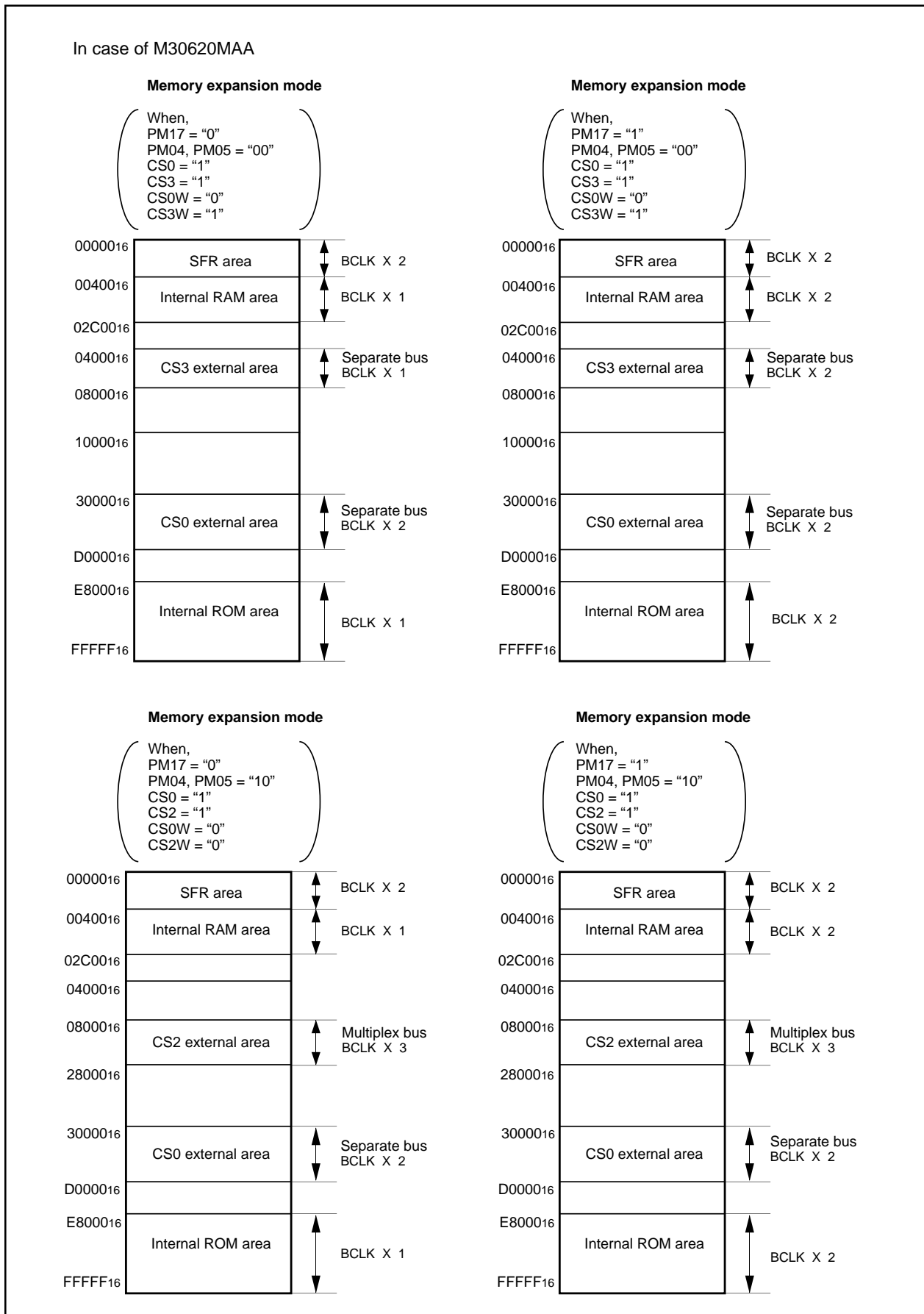

Figure 3.4.4. Relation of processor mode and the wait bit (PM17, CSiW) (2)

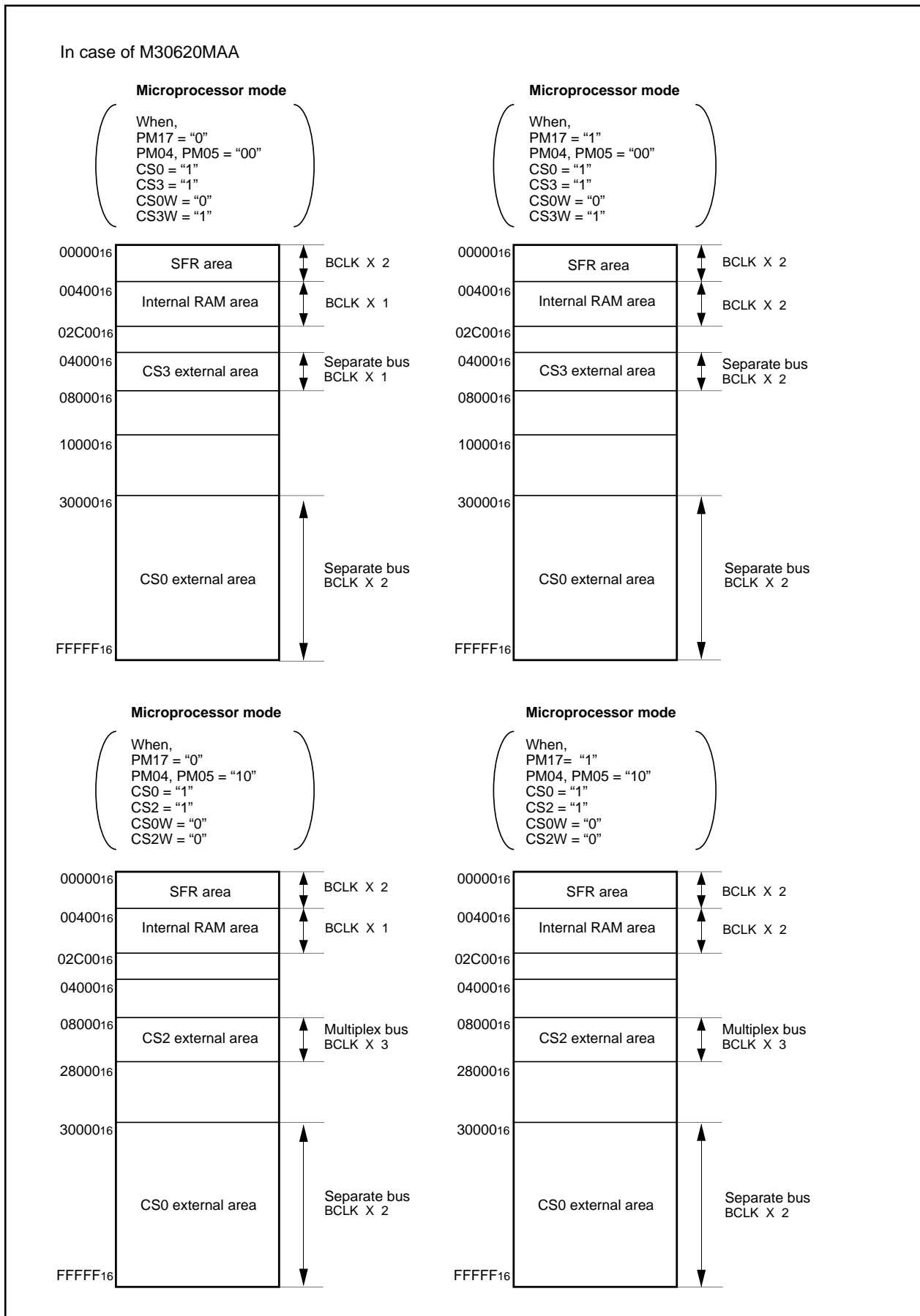

Figure 3.4.5. Relation of processor mode and the wait bit (PM17, CSiW) (3)

**(2) RDY function usage**

To use the RDY function, set a software wait.

The RDY function operates when the BCLK signal falls with the RDY pin at "L"; the bus does not vary for 1 BCLK, and the state at that moment is held.

The RDY function holds the state of bus for the period in which the RDY pin is at "L", and releases it when the BCLK signal falls with the RDY pin at "H". Figure 3.4.6 shows an example of RDY circuit (f(XIN)=10MHz) that holds the state of bus for 1 BCLK.

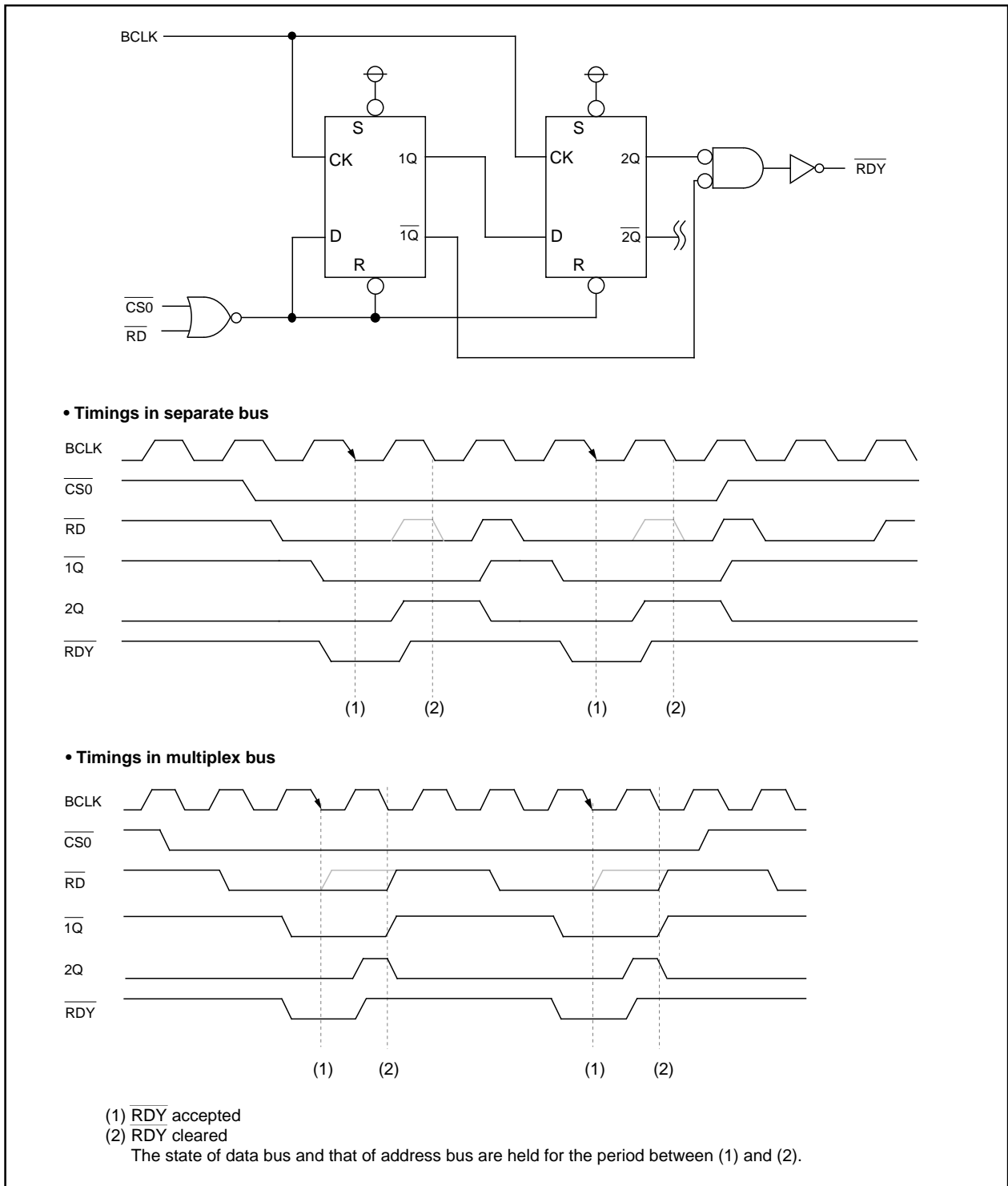

**Figure 3.4.6. Example of RDY circuit holding state of bus for 1 BCLK (f(XIN)=10MHz)**

### 3.4.3 Connectable Memories

Connectable memories and their maximum frequencies are given here;

M16C/62A group maximum frequency is

16MHz (without the wait) for  $V_{cc}=5V$ ,

10MHz (with the one wait) for  $V_{cc}=3V$

#### (1) Flash memories (Read only mode)

(a) 3V without wait

| Maximum frequency (MHz) | Model No.          |
|-------------------------|--------------------|
| 3.57                    | M5M29GB/T160BVP-80 |

(b) 3V with wait

| Maximum frequency (MHz) | Model No.          |
|-------------------------|--------------------|
| 8.33                    | M5M29GB/T160BVP-80 |

#### (2) SRAM

(a) 3V without wait

| Maximum frequency (MHz) | Model No.                          |
|-------------------------|------------------------------------|
| 5.12                    | M5M54R08AJ-12<br>M5M54R16AJ,ATP-12 |

(b) 3V with wait

| Maximum frequency (MHz) | Model No.                          |
|-------------------------|------------------------------------|
| 10.0                    | M5M54R08AJ-12<br>M5M54R16AJ,ATP-12 |

### 3.5 Releasing an External Bus ( $\overline{\text{HOLD}}$ input and $\overline{\text{HLDA}}$ output)

The Hold feature is to relinquish the address bus, the data bus, and the control bus on M16C/62A side in line with the Hold request from the bus master other than M16C/62A when the two or more bus masters share the address bus, the data bus, and the control bus. The Hold feature is effective only in memory expansion mode and microprocessor mode.

The sequence of using the Hold feature may be:

1. The external bus master turns the input level of the  $\overline{\text{HOLD}}$  terminal to "L".
2. When M16C/62A becomes ready to relinquish buses, each bus becomes high-impedance state at the falling edge of BCLK.
3. The  $\overline{\text{HLDA}}$  terminal becomes "L" at the rising edge of the next BCLK.
4. The external bus master uses a bus.
5. When the external bus master finishes using a bus, the external bus master returns the input level of the  $\overline{\text{HOLD}}$  terminal to "H".
6. The output from  $\overline{\text{HLDA}}$  terminal becomes "H" at the rising edge of the next BCLK.
7. Each bus returns from the high-impedance state to the former state at the falling edge of the next BCLK.

As given above, each bus invariably gets in the high-impedance state while the  $\overline{\text{HLDA}}$  output is "L". Also, M16C/62A does not relinquish buses during a bus cycle. That is, if a Hold request comes in during a bus cycle, the  $\overline{\text{HLDA}}$  output become "L" after that bus cycle finishes.

In the Hold state, the state of each terminal becomes as follows.

- **Address bus A0 to A19**

High-impedance state. The case in which A16 to A19 are used as ports P40 to P43 (64K byte address space) and the case in which A9 to A19 are used as ports P31 to P37 and P40 to P43 (multiplex for the whole area) in microprocessor mode and in memory expansion mode too fall under this category.

- **Data bus D0 to D15**

High-impedance state. The case in which D8 to D15 are used as ports P10 to P17 (8-bit external bus width) and the case in which D0 to D15 are used as ports P00 to P07 and P10 to P17 (multiplex for the whole area) in microprocessor mode and in memory expansion mode too fall under this category.

- **$\overline{\text{RD}}$ ,  $\overline{\text{WR}}$ ,  $\overline{\text{WRL}}$ ,  $\overline{\text{WRH}}$ ,  $\overline{\text{BHE}}$**

High-impedance state.

- **ALE**

An internal clock signal having the same phase as BCLK is output.

- **$\overline{\text{CS0}}$  to  $\overline{\text{CS3}}$**

High-impedance state. The case in which ports are selected by the chip selection control register too falls under this category.

Figure. 3.5.1 shows an example of relinquishing external buses.

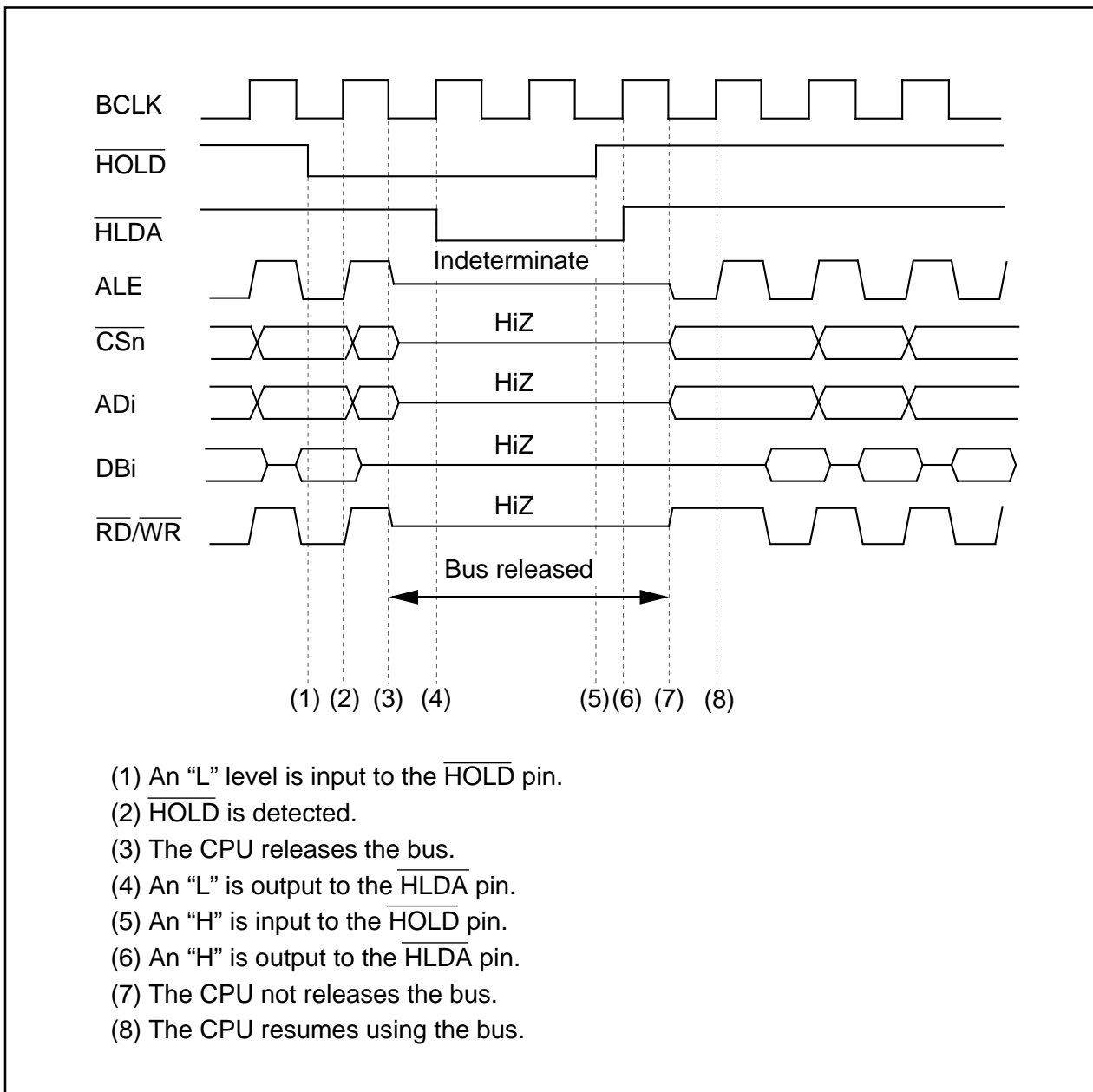

- (1) An "L" level is input to the  $\overline{\text{HOLD}}$  pin.
- (2)  $\overline{\text{HOLD}}$  is detected.
- (3) The CPU releases the bus.
- (4) An "L" is output to the  $\overline{\text{HLDA}}$  pin.
- (5) An "H" is input to the  $\overline{\text{HOLD}}$  pin.
- (6) An "H" is output to the  $\overline{\text{HLDA}}$  pin.
- (7) The CPU not releases the bus.
- (8) The CPU resumes using the bus.

Figure 3.5.1. Example of releasing the external bus

### 3.6 Precautions for External Bus

The external ROM version can operate only in the microprocessor mode, so be sure to perform the following:

- Connect the CNVss pin to Vcc.

#### 4. Reference

##### Data Sheet

M16C/62A group data sheet Rev.B1

(Use the latest version on the Home page: <http://www.renesas.com/>)

##### User's Manual

M16C/62A group user's manual Rev.1.0

(Use the latest version on the Home page: <http://www.renesas.com/>)

#### 5. Web-site and contact for support

Renesas Technology Corporation Semiconductor Home page

<http://www.renesas.com/>

E-mail Support

E-mail: [support\\_apl@renesas.com](mailto:support_apl@renesas.com)



————— Keep safety first in your circuit designs! —————

- Renesas Technology Corporation puts the maximum effort into making semiconductor products better and more reliable, but there is always the possibility that trouble may occur with them. Trouble with semiconductors may lead to personal injury, fire or property damage. Remember to give due consideration to safety when making your circuit designs, with appropriate measures such as (i) placement of substitutive, auxiliary circuits, (ii) use of non-flammable material or (iii) prevention against any malfunction or mishap.

————— Notes regarding these materials —————

- These materials are intended as a reference to assist our customers in the selection of the Renesas Technology Corporation product best suited to the customer's application; they do not convey any license under any intellectual property rights, or any other rights, belonging to Renesas Technology Corporation or a third party.
- Renesas Technology Corporation assumes no responsibility for any damage, or infringement of any third-party's rights, originating in the use of any product data, diagrams, charts, programs, algorithms, or circuit application examples contained in these materials.
- All information contained in these materials, including product data, diagrams, charts, programs and algorithms represents information on products at the time of publication of these materials, and are subject to change by Renesas Technology Corporation without notice due to product improvements or other reasons. It is therefore recommended that customers contact Renesas Technology Corporation or an authorized Renesas Technology Corporation product distributor for the latest product information before purchasing a product listed herein.

The information described here may contain technical inaccuracies or typographical errors. Renesas Technology Corporation assumes no responsibility for any damage, liability, or other loss rising from these inaccuracies or errors.

Please also pay attention to information published by Renesas Technology Corporation by various means, including the Renesas Technology Corporation Semiconductor home page (<http://www.renesas.com>).

- When using any or all of the information contained in these materials, including product data, diagrams, charts, programs, and algorithms, please be sure to evaluate all information as a total system before making a final decision on the applicability of the information and products. Renesas Technology Corporation assumes no responsibility for any damage, liability or other loss resulting from the information contained herein.
- Renesas Technology Corporation semiconductors are not designed or manufactured for use in a device or system that is used under circumstances in which human life is potentially at stake. Please contact Renesas Technology Corporation or an authorized Renesas Technology Corporation product distributor when considering the use of a product contained herein for any specific purposes, such as apparatus or systems for transportation, vehicular, medical, aerospace, nuclear, or undersea repeater use.
- The prior written approval of Renesas Technology Corporation is necessary to reprint or reproduce in whole or in part these materials.
- If these products or technologies are subject to the Japanese export control restrictions, they must be exported under a license from the Japanese government and cannot be imported into a country other than the approved destination.  
Any diversion or reexport contrary to the export control laws and regulations of Japan and/or the country of destination is prohibited.
- Please contact Renesas Technology Corporation for further details on these materials or the products contained therein.