

# RX62N Group

R01AN0629EJ0101

## Ethernet Transmit and Receive Settings

Rev.1.01

Mar 31, 2011

### Introduction

This application note presents a sample program that makes settings for transmitting and receiving Ethernet/IEEE802.3 frames using the Ethernet controller (ETHERC) and Ethernet DMA controller (EDMAC).

### Target Devices

- RX62N Group MCU (product number: R5F562N8BDBG)
- LAN8700i, manufactured by Standard Microsystems Corporation

### Target Board

- Renesas Starter Kit +(product number: R0K5562N0C000BE)

### Notes

- RX62N group's capacity of built-in ROM and built-in RAM is different in each product. Please correct the section arrangement in Table 7.1 according to the product used.
- The sample program uses the auto-negotiation function to select the communication mode. If the amount of time required for auto-negotiation by the RX62N and the connection partner of the RX62 differs considerably, communication may fail even though auto-negotiation is successful. Please adjust it according to 4.6.1.
- Please note that the Renesas Starter Kit +(product number: R0K5562N0C000BE) supports the MII (Media Independent Interface) only, and doesn't support RMII (Reduced Media Independent Interface).

### Contents

1. Introduction.....	2
2. Description of Initial Settings.....	4
3. Description of Physical Layer Transceiver (PHY) Auto-Negotiation Settings.....	6
4. Description of Transmit/Receive Settings.....	18
5. Endian Mode Selection in Sample Program.....	49
6. Interface (MII/RMII) Selection in Sample Program.....	49
7. Allocation of Sections in Sample Program.....	50
8. Note on Use of Renesas Starter Kit +.....	50
9. Reference Documents.....	51

## 1. Introduction

### 1.1 Specifications

- The sample program supports the big endian and little endian operating modes of the RX62N.
- The sample program supports the Media Independent Interface (MII) and Reduced Media Independent Interface (RMII).
- The sample program does not include any interrupt handling functionality. In order to use interrupts, it is necessary for the customer to create the necessary program code separately.
- The sample program does not include routines for handling transmit or receive errors. If error handling functionality is required, it is necessary for the customer to create the necessary program code separately.
- After a reset is canceled, the sample program makes settings for the clock generation circuit, module stop function, and I/O registers.
- The LAN8700i from Standard Microsystems Corporation is used as the Ethernet physical layer transceiver (PHY).
- The auto-negotiation function is used for the link to the Ethernet physical layer transceiver (PHY).
- The sample program obtains the auto-negotiation result from the Ethernet physical layer transceiver (PHY) connected to the RX62N and makes ETHERC settings to match the connection mode information (full-duplex mode or half-duplex mode, transfer speed\* of 10 Mbps or 100 Mbps) obtained.
- The sample program allows selection between the following two types of processing.
  - Transmission of 10 Ethernet frames
  - Reception of 10 Ethernet frames

Note: \* This setting is needed only when using the RMII. When the MII is used, the transfer speed is detected automatically by the ETHERC from the clock frequency of the physical layer transceiver (PHY), so there is no need to specify the transfer speed.

### 1.2 Functions Used

- Clock generation circuit
- Module stop function
- I/O ports
- Ethernet controller (ETHERC)
- Ethernet controller direct memory access controller (EDMAC)

### 1.3 Applicable Conditions

- MCU: RX62N Group
- Evaluation board: Renesas Starter Kit +(product number: R0K5562N0C000BE)
- Operating frequencies:
  - Input clock: 12 MHz
  - System clock (ICLK): 96 MHz
  - Peripheral module clock (PCLK): 48 MHz
  - External bus clock (BCLK) and SDRAM clock (SDCLK): 24 MHz
- Operating mode: Single-chip mode
- Integrated development environment: Renesas Electronics High-performance Embedded Workshop, Ver. 4.07.00.007
- C compiler: Renesas Electronics RX Family C/C++ Compiler, Ver. 1.00.00.001
- Compile options:
  - Big endian operation
    - cpu=rx600 -endian=big -patch=rx610 -include="\$(WORKSPDIR)\src\bsp", "\$(WORKSPDIR)\src\driver"
    - output=obj="\$(CONFIGDIR)\\$(FILELEAF).obj" -debug -nologo
  - Little endian operation
    - cpu=rx600 -patch=rx610 -include="\$(WORKSPDIR)\src\bsp", "\$(WORKSPDIR)\src\driver"
    - output=obj="\$(CONFIGDIR)\\$(FILELEAF).obj" -debug -nologo
- Optimizing linkage editor: Renesas Electronics Optimizing Linkage Editor, Ver. 10.00.00.001
- Linker options:
  - noprelink -rom=D=R,D\_1=R\_1,D\_2=R\_2 -nomessage -list="\$(CONFIGDIR)\\$(PROJECTNAME).map"
  - show=all -nooptimize
  - start=B\_RX\_DESC,B\_TX\_DESC,B\_RX\_BUFF\_1,B\_TX\_BUFF\_1,B\_1,R\_1,B\_2,R\_2, B,R,SU,SI, BETH\_BUFF/01000,PRresetPRG/0FFFF8000,C\_1,C\_2,C,C\$,D\*,P,PIntPRG,W\*/0FFFF8100, FIXEDVECT/0FFFFFFD0 -nologo
  - output="\$(CONFIGDIR)\\$(PROJECTNAME).abs" -end -input="\$(CONFIGDIR)\\$(PROJECTNAME).abs"
  - form=stype -output="\$(CONFIGDIR)\\$(PROJECTNAME).mot" -exit

## 2. Description of Initial Settings

An initial settings program, which performs minimal hardware initialization processing such as memory initialization after a power-on reset, is required in order to use the Ethernet driver of the sample program. Sample settings for the initial settings program are described below.

### 2.1 Description of Initial Settings Program

The initial settings program comprises multiple source files, including `resetprg.c`, which contains the main `PowerON_Reset_PC` function, and `hwsetup.c`, which is called as a function. The main source files described below.

- resetprg.c**  
 The file **resetprg.c** is generated automatically by High-performance Embedded Workshop and contains declarations for the `PowerON_Reset_PC` function. `PowerON_Reset_PC` is the first function run after a reset is canceled. The start address of this function is set in the reset vector defined in `vecttbl.c`. Figure 2.1 shows the processing sequence of the `PowerON_Reset_PC` function.
- hwsetup.c**  
 The file **hwsetup.c** contains declarations for the `HardwareSetup` function called by the `PowerON_Reset_PC` function. The `HardwareSetup` function in turn calls the functions that make settings for the clock generation circuit, module stop function, and I/O ports. These are the minimum hardware settings for the system. Figure 2.2 shows the processing sequence of the `HardwareSetup` function.

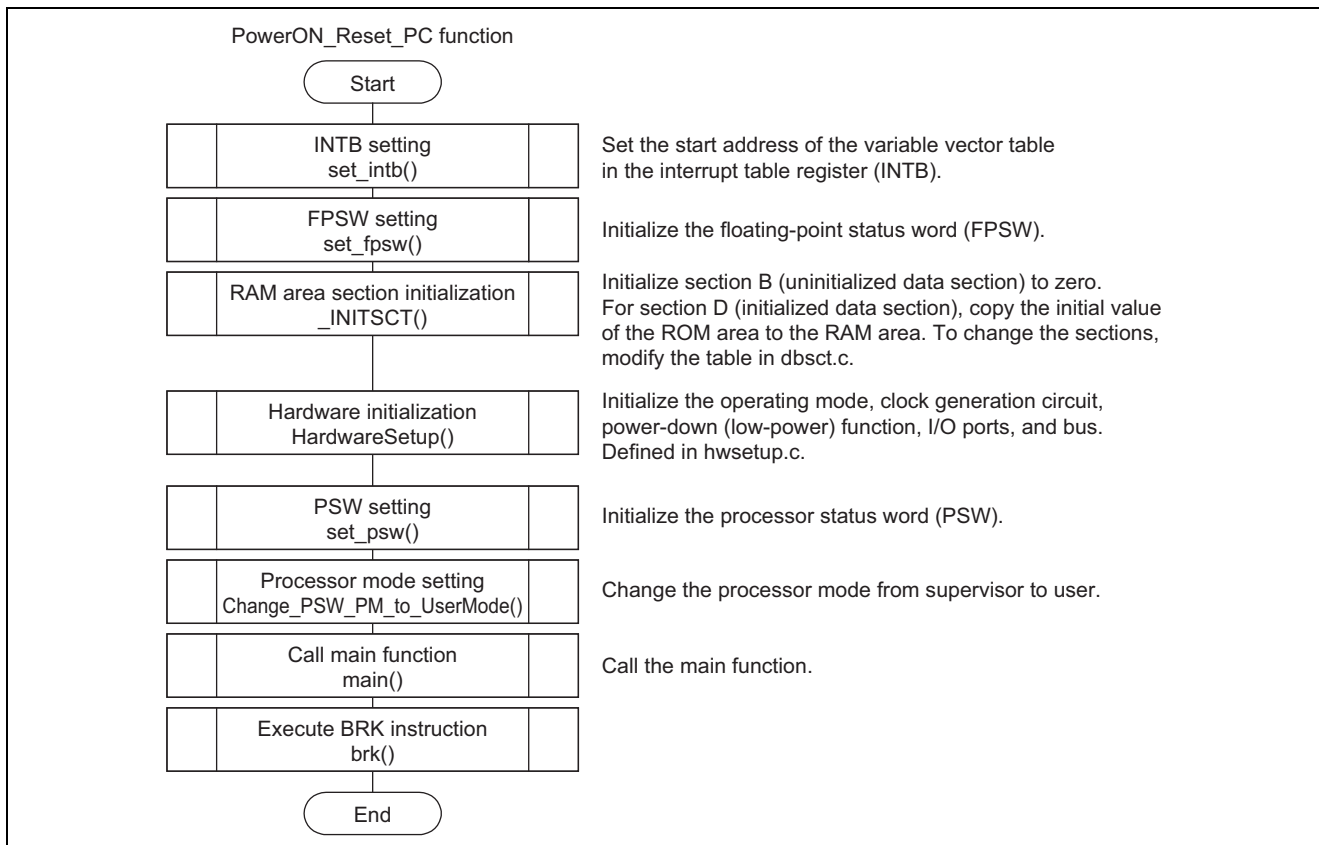

Figure 2.1 Processing Sequence of Reset Program

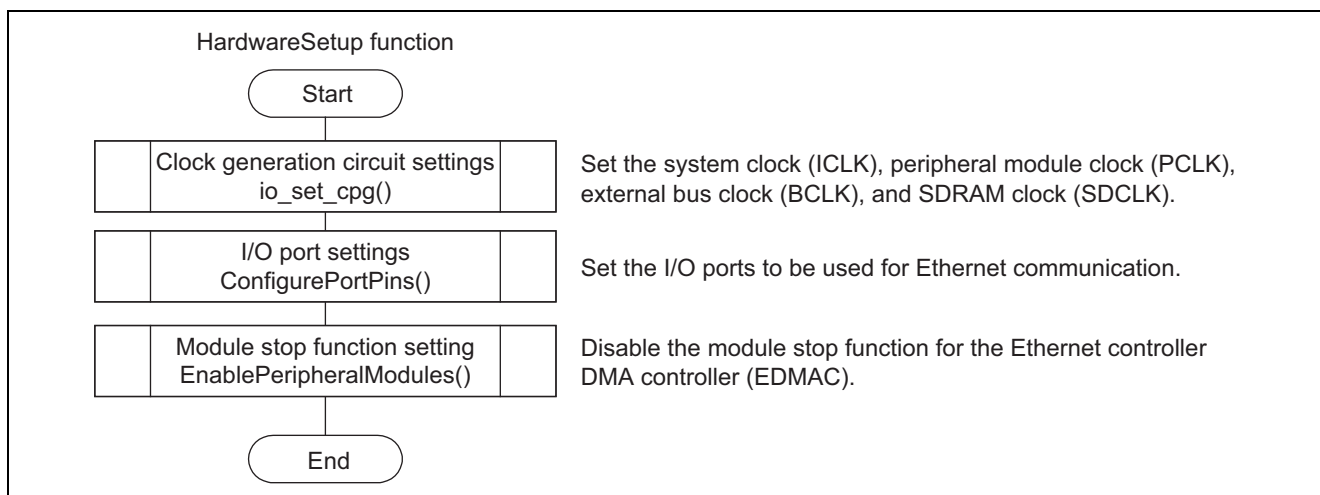

Figure 2.2 Processing Sequence of Hardware Initialization Function

## 2.2 Details of Initial Settings

Table 2.1 lists the settings used in the sample program.

Table 2.1 Sample Program Settings

Module	Settings
Operating mode	Single-chip mode
Clock generation circuit	System clock: 96 MHz Peripheral module clock: 48 MHz External bus clock and SDRAM clock: 24 MHz
Module stop function	Disabled for Ethernet controller DMA controller (EDMAC)
I/O ports	Pin settings used for Ethernet communication

## 2.3 Notes on Initial Settings

Do not access the static variable area before the `_INIT_SCT` function is executed.

The C language static variable area is initialized by executing the `_INIT_SCT` function. Note that accessing the area before the function has been run will return undefined values.

### 3. Description of Physical Layer Transceiver (PHY) Auto-Negotiation Settings

The sample program uses the Ethernet physical layer transceiver (PHY) to perform auto-negotiation. The auto-negotiation result is read via the PHY interface register (PIR) of the ETHERC.

#### 3.1 Operation of Functions Used

The actual physical layer link processing is performed using the functionality of the Ethernet physical layer transceiver (PHY). This enables the RX62N to obtain the link result simply by reading it from the Ethernet physical layer transceiver (PHY). The sample program enables the auto-negotiation function of the physical layer transceiver (PHY). For details of the functions of the Ethernet physical layer transceiver (PHY), see the Ethernet physical layer transceiver (PHY) datasheet.

The interface between the ETHERC and the Ethernet physical layer transceiver (PHY) is standardized according to the IEEE802.3 Media Independent Interface (MII) or Reduced Media Independent Interface (RMII). Figures 3.1 and 3.2 show connection examples for the RX62N and LAN8700i.

The auto-negotiation result is stored in the internal registers of the Ethernet physical layer transceiver (PHY) and can be read by using a serial interface (Serial Management Interface) employing the MDC and MDIO pins. The RX62N can read from and write to these pins by using the PIR register. The procedure for accessing the internal registers of the Ethernet physical layer transceiver (PHY) is described in 3.2, Procedure for Accessing MII/RMII Registers.

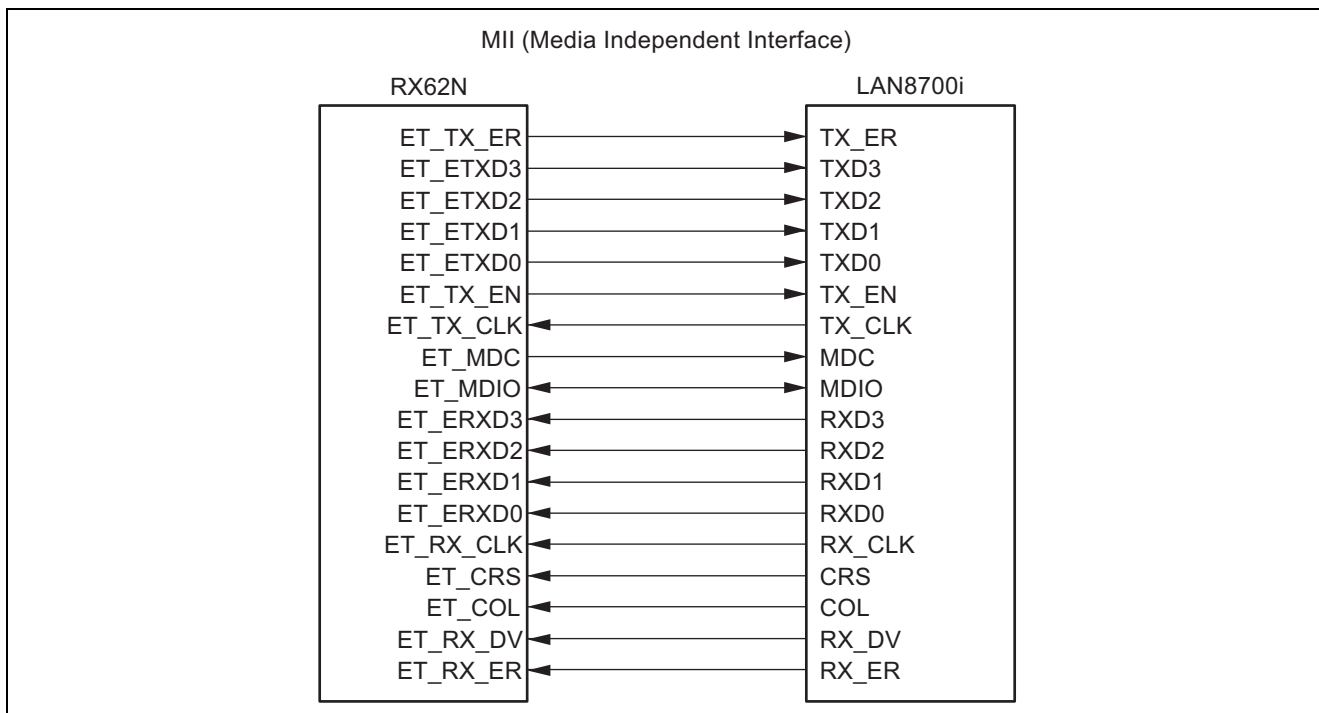

Figure 3.1 LAN8700i Connection Example (MII)

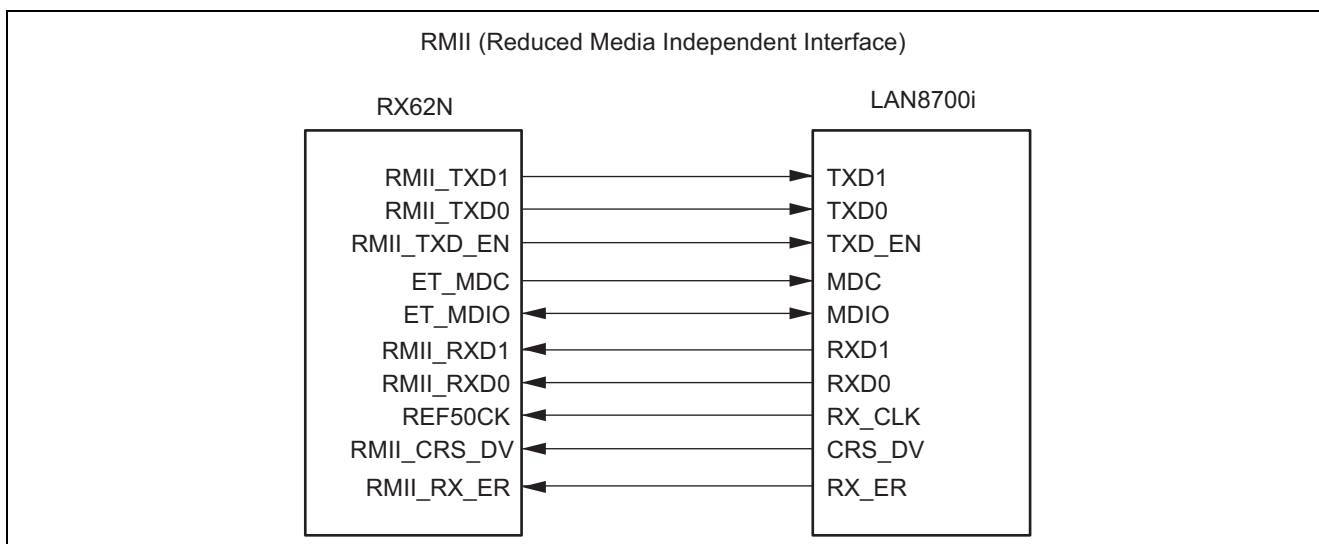

Figure 3.2 LAN8700i Connection Example (RMII)

### 3.2 Procedure for Accessing MII/RMII Registers

The procedure for accessing the internal MII/RMII registers of the Ethernet physical layer transceiver (PHY) is described below.

The serial interface (Serial Management Interface) used to access the MII/RMII registers consists of MDC and MDIO (both pin names used on the ETHERC side). MDC is the clock pin used for synchronization, and MDIO is the data I/O pin. The states of the pins can be referenced or changed by means of the PHY interface register (PIR) of the ETHERC. There are no control pins, so data must always be output in the format stipulated by the MII/RMII specification (MII/RMII management frames). Figure 3.3 shows an MII/RMII management frame. The sample program executes Z0 output for one bit period in the IDLE state. The IEEE802.3 specification does not mention clock input, but it is provided for safety because without it some physical layer transceiver (PHY) devices cannot connect properly.

The MII/RMII management frame I/O is performed in order in 1-bit units, starting from PRE. Figures 3.4 to 3.7 illustrate the I/O sequence for 1-bit units. Make sure that the MDC and MDIO I/O timing conform to the IEEE802.3 specification. Table 3.1 and figure 3.8 show the I/O timing as stipulated in the IEEE802.3 specification.

Access Type	MII/RMII Management Frame							
	PRE	ST	OP	PHYAD	REGAD	TA	DATA	IDLE
Number of bits	32	2	2	5	5	2	16	—
Read	1..1	01	10	00001	RRRRR	Z0	D..D	—
Write	1..1	01	01	00001	RRRRR	10	D..D	X

[Legend]

- PRE : 32 consecutive 1s
- ST : Write 01 to indicate the start of the frame.
- OP : Write the code indicating the access type.
- PHYAD : Write 0001 if the PHY address is 1 (sequential write starting with the MSB).  
This value varies according to the PHY address.
- REGAD : Write 0001 if the register address is 1 (sequential write starting with the MSB).  
This value varies according to the PHY register address.
- TA : Time for switching data transmission source on MII/RMII interface  
(a) For write: Write 10.  
(b) For read: Perform bus release (notation: Z0).
- DATA : 16 bits of data. Sequentially write or read from MSB.  
(a) For write: Write 16 bits of data.  
(b) For read: Read 16 bits of data.
- IDLE : Wait time until next MII management format input  
(a) For write: Perform independent bus release (notation: X).  
(b) For read: Bus already released during TA; control unnecessary.

Figure 3.3 MII/RMII Management Frame Format

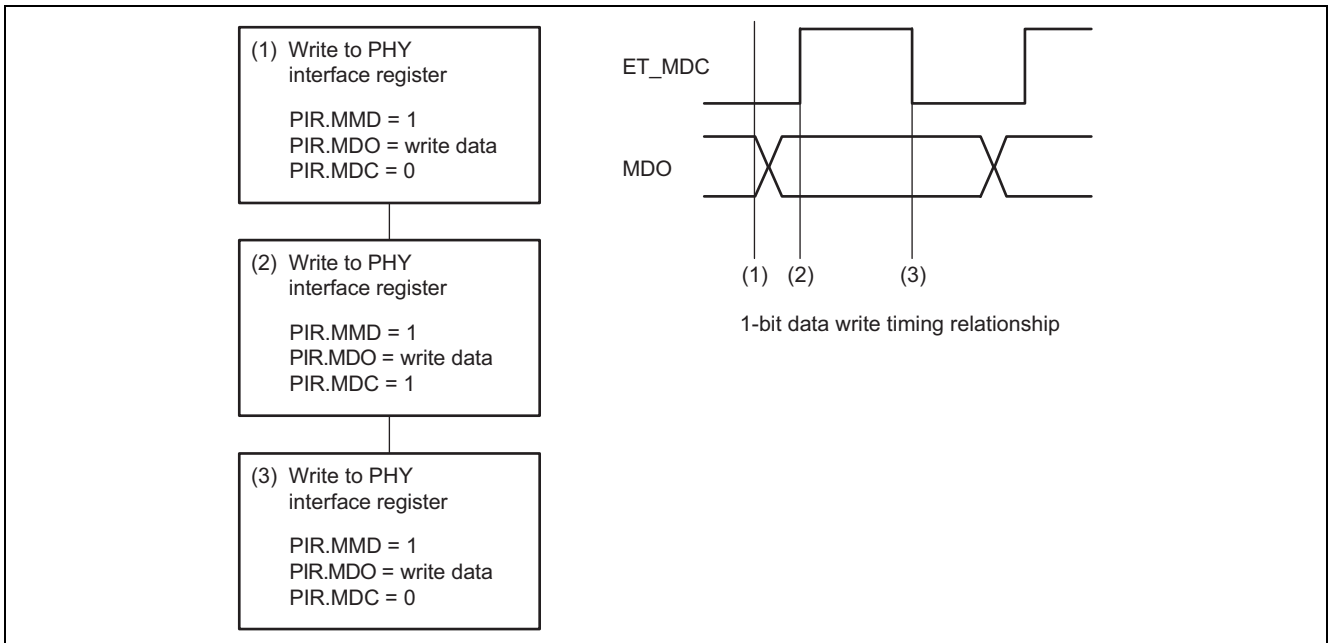

Figure 3.4 1-Bit Data Write Sequence

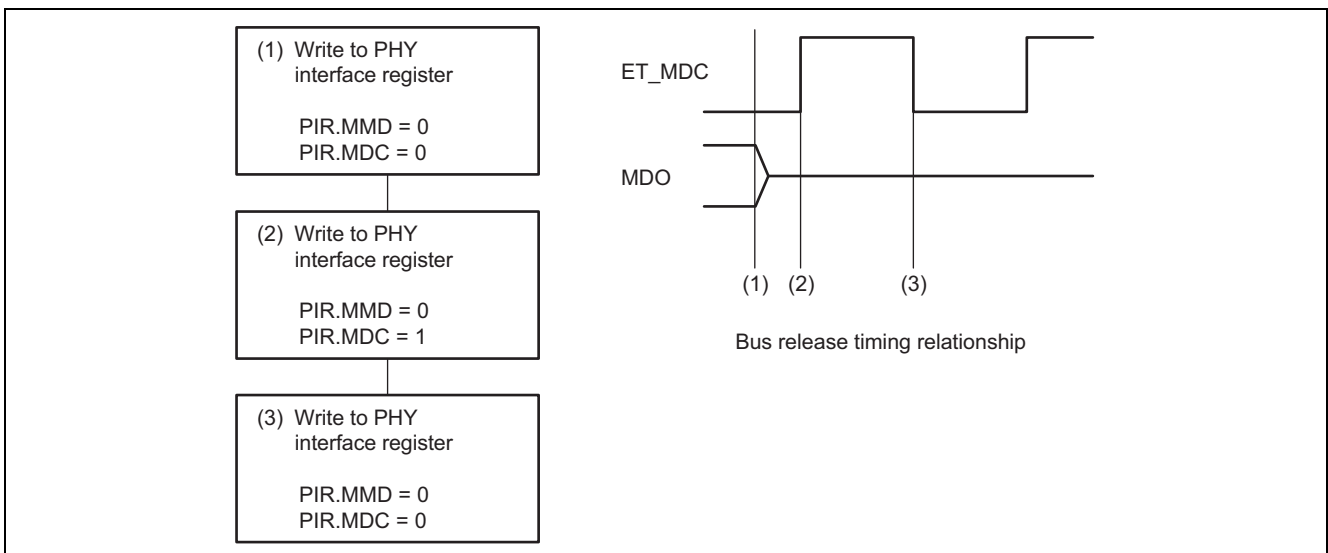

Figure 3.5 Bus Release Sequence (TA During Read)

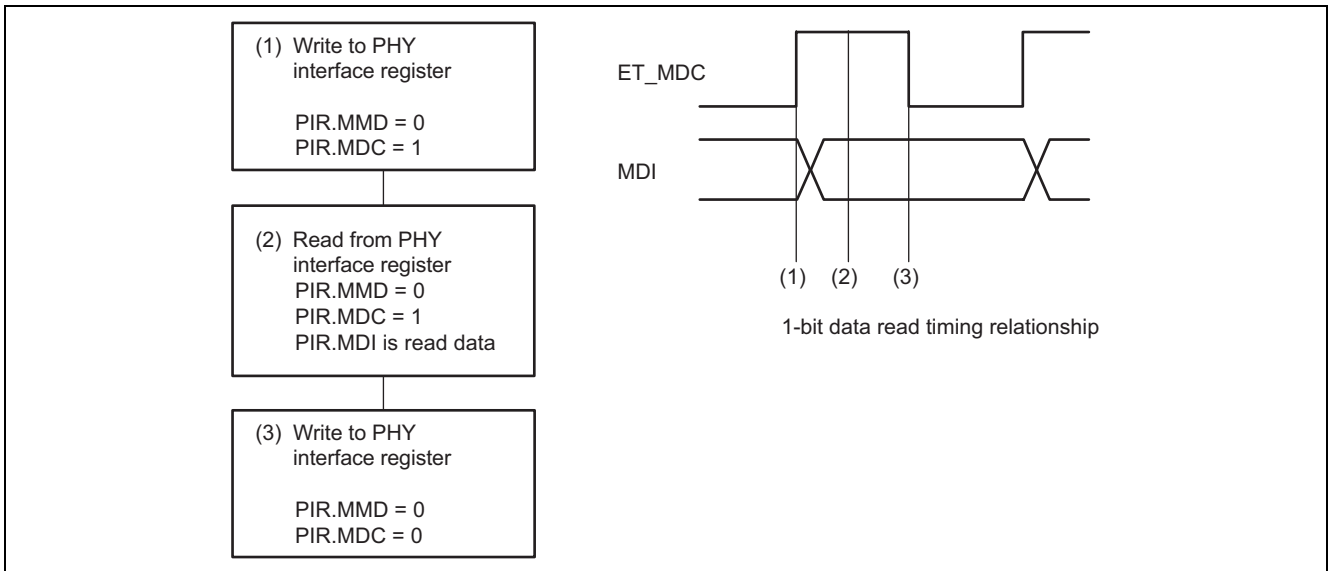

Figure 3.6 1-Bit Data Read Sequence

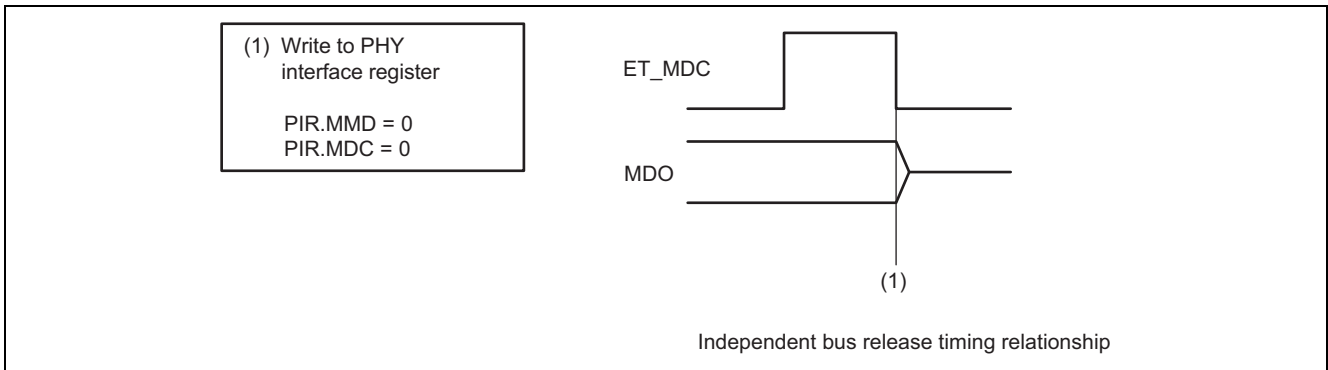

Figure 3.7 Independent Bus Release Sequence (IDLE During Write)

Table 3.1 MDC/MDIO I/O Timing

Item	Symbol	Min.	Max.	Unit
MDC high-level pulse width	$t_1$	160		ns
MDC low-level pulse width	$t_2$	160		ns
MDC cycle time	$t_3$	400		ns
MDIO setup time	$t_4$	10		ns
MDIO hold time	$t_5$	10		ns
MDIO output delay time	$t_6$	0	300	ns

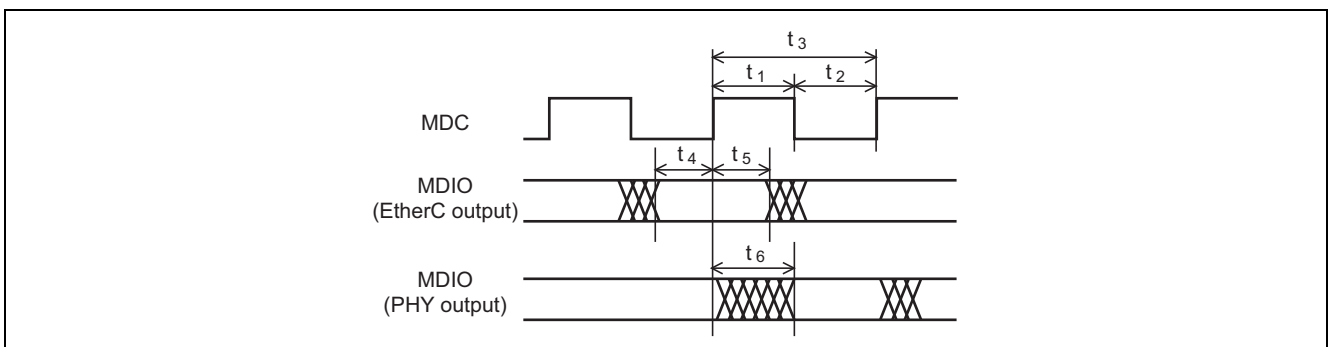

Figure 3.8 MDC/MDIO I/O Timing

### 3.3 Description of Physical Layer Transceiver (PHY) Auto-Negotiation Settings

- phy.c

This file contains declarations for the function that initializes the physical layer transceiver (PHY) (`phy_init` function) and the function that obtains the auto-negotiation result (`phy_set_autonegotiate` function). Figure 3.9 shows the processing sequence of the `phy_init` function and figure 3.10 of the `phy_set_autonegotiate` function. Figures 3.11 to 3.16 show the processing sequences of the MII/RMII register read function (`_phy_read` function) and MII/RMII register write function (`_phy_write` function), which are executed within the `phy_init` function and `phy_set_autonegotiate` function, and their lower level functions.

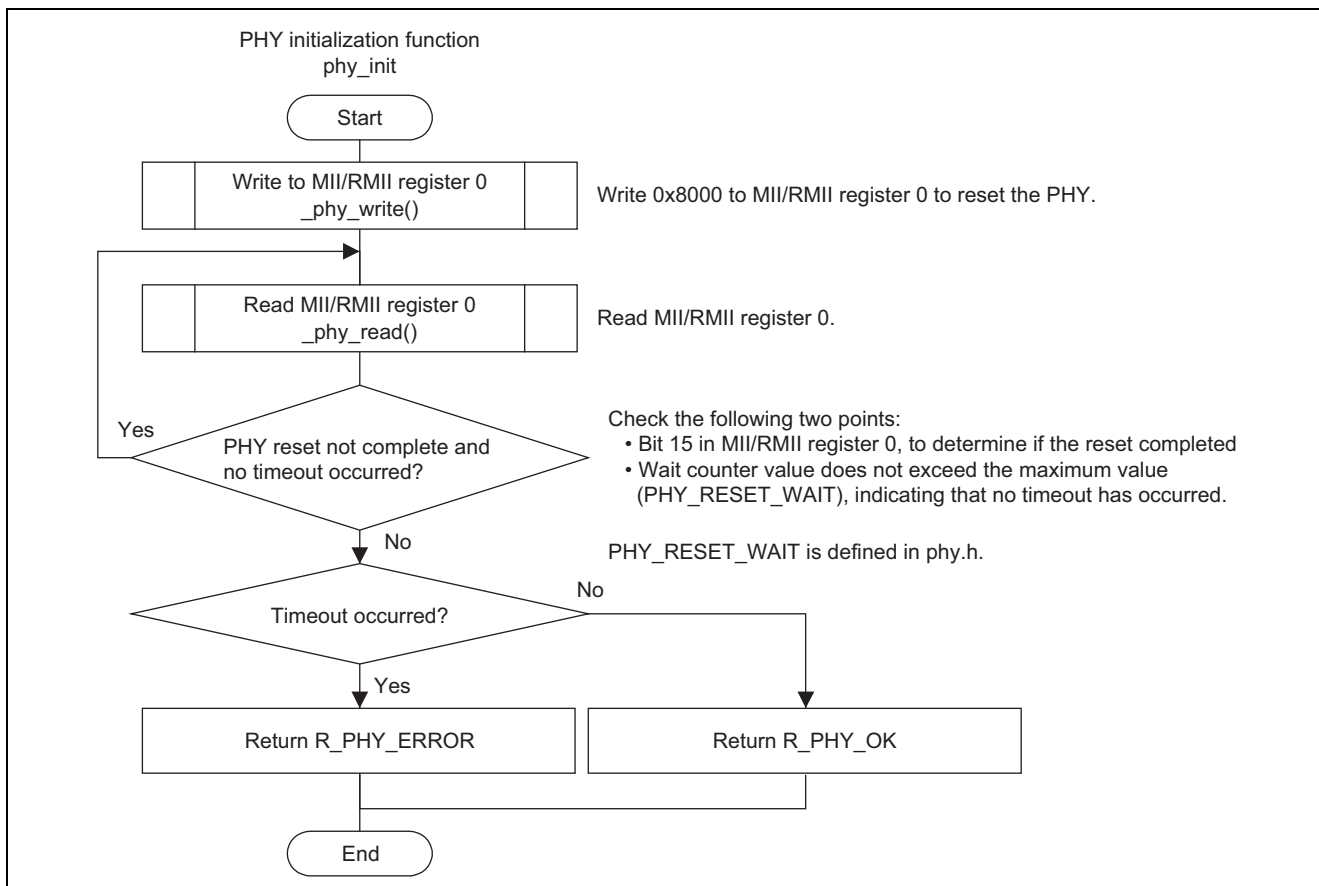

Figure 3.9 Processing Sequence of Physical Layer Transceiver (PHY) Initialization Function

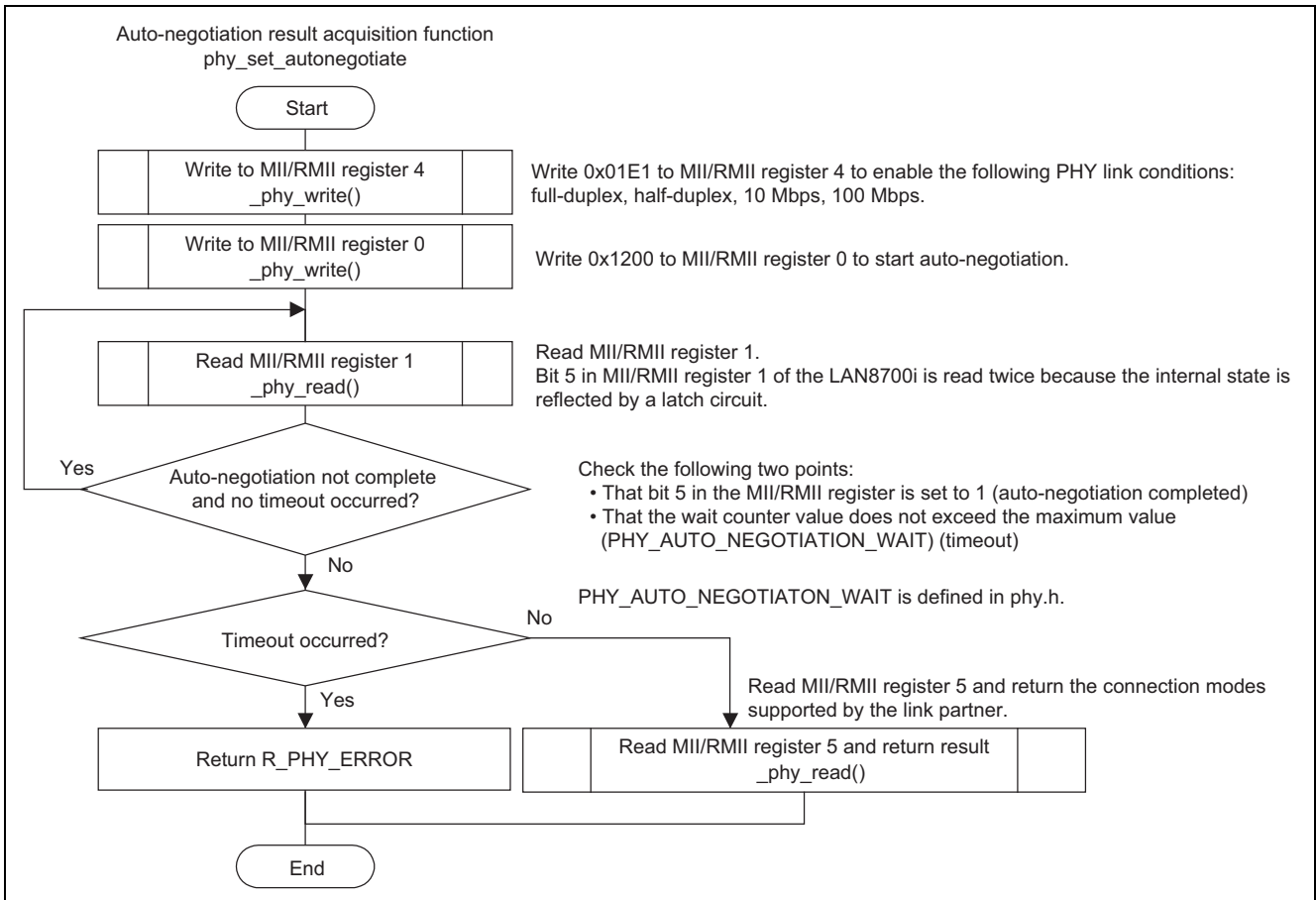

Figure 3.10 Auto-Negotiation Result Acquisition Function

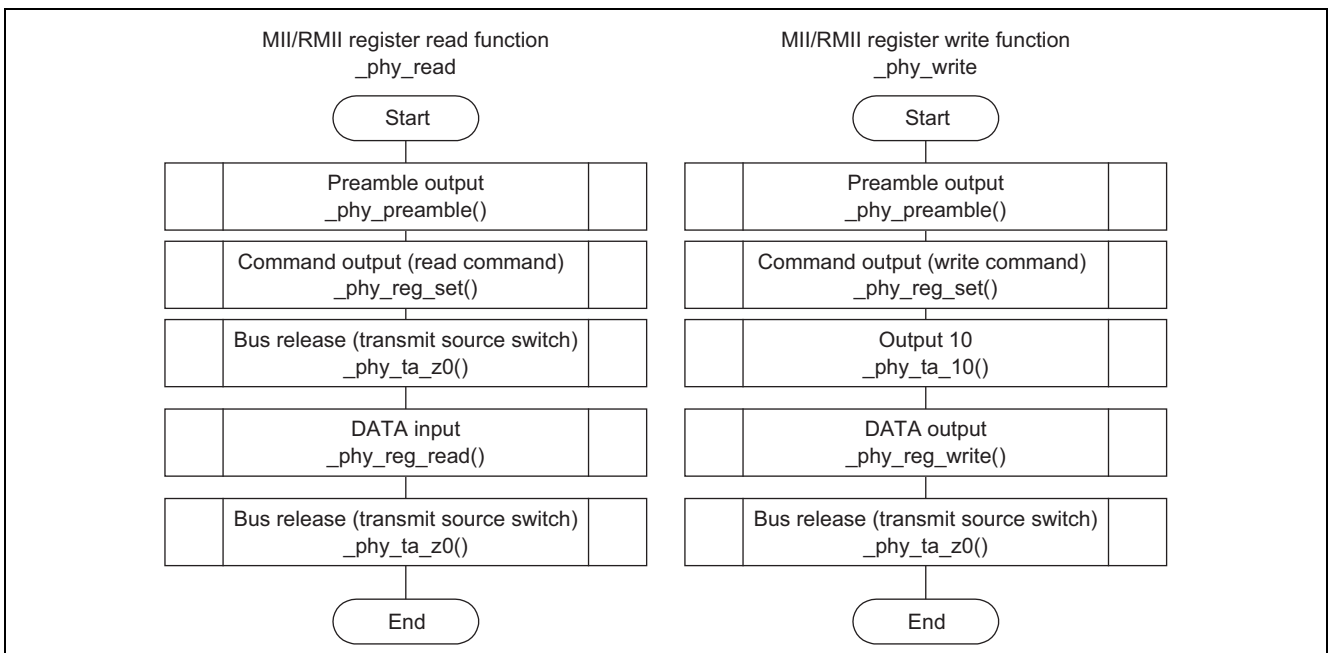

Figure 3.11 Processing Sequence of MII/RMII Register Access (1)

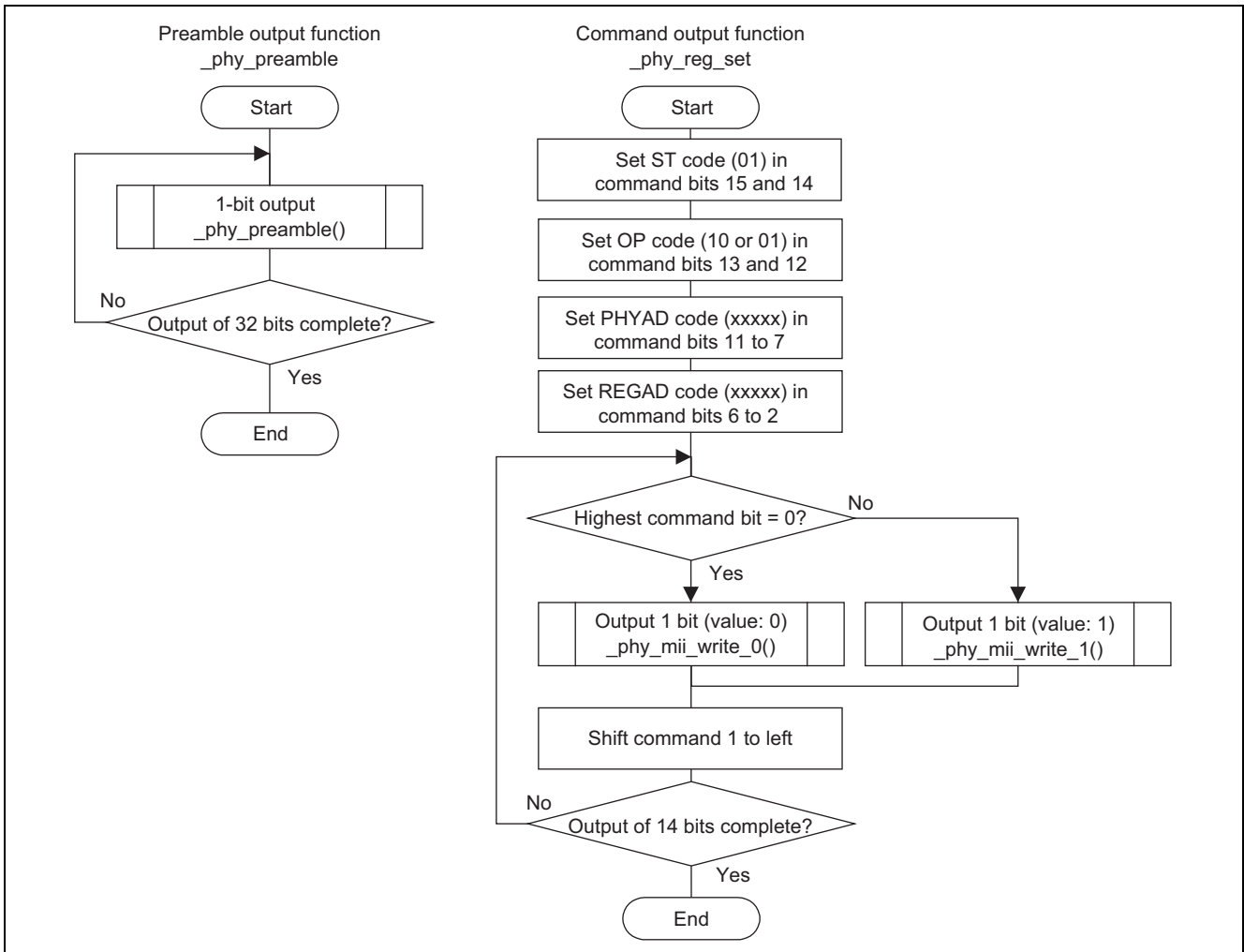

Figure 3.12 Processing Sequence of MII/RMII Register Access (2)

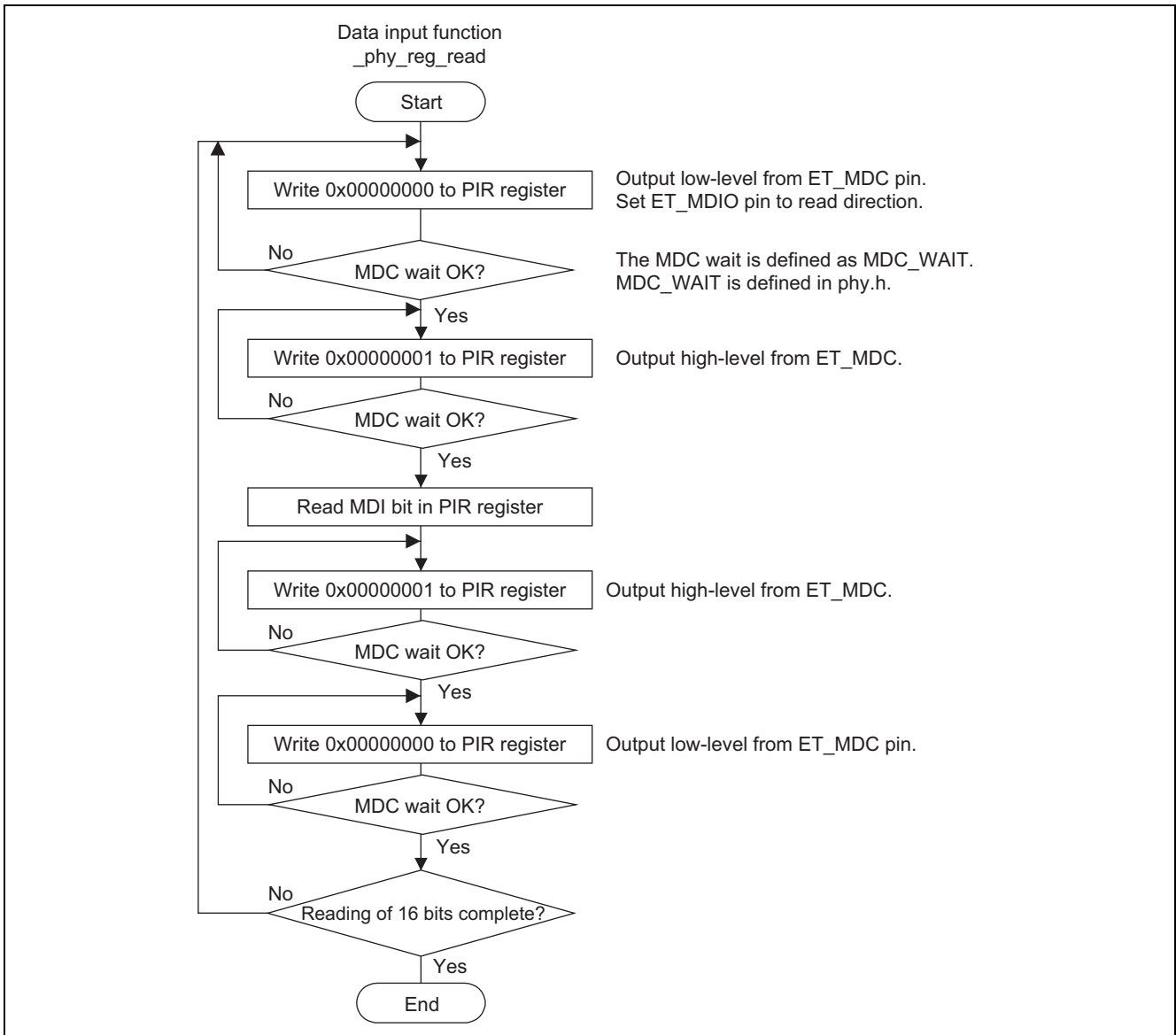

Figure 3.13 Processing Sequence of MII/RMII Register Access (3)

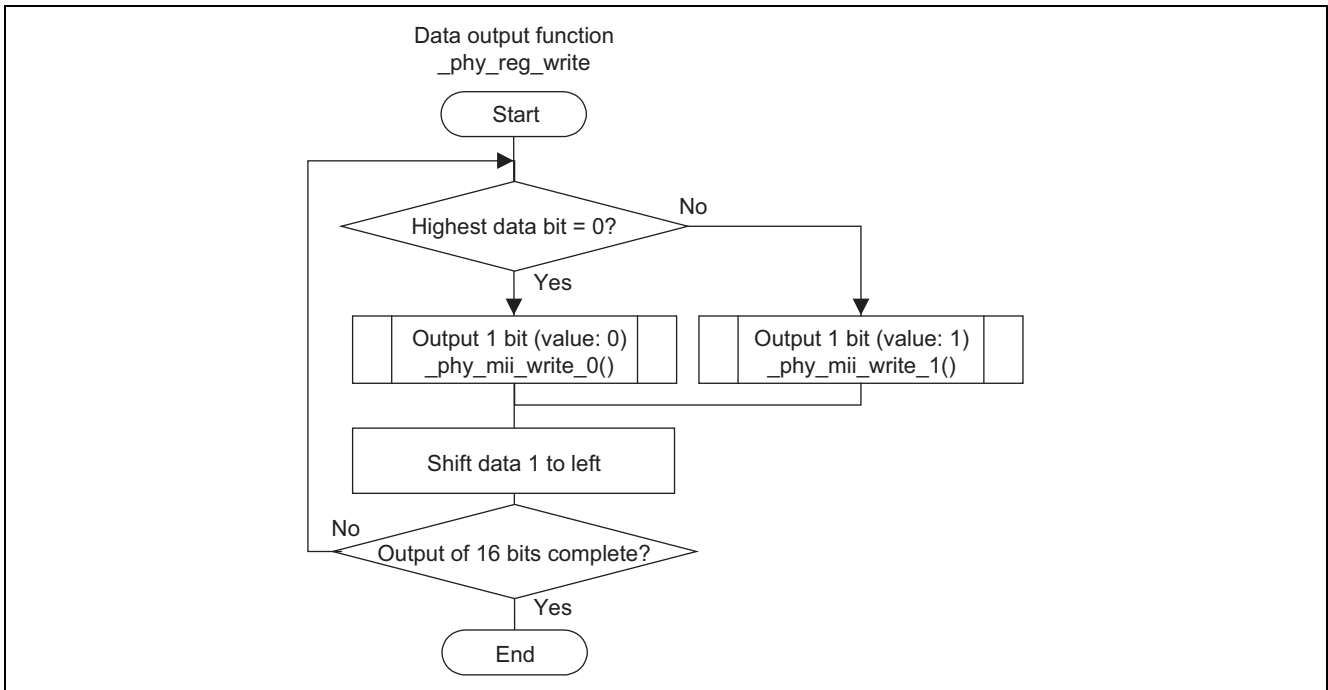

Figure 3.14 Processing Sequence of MII/RMII Register Access (4)

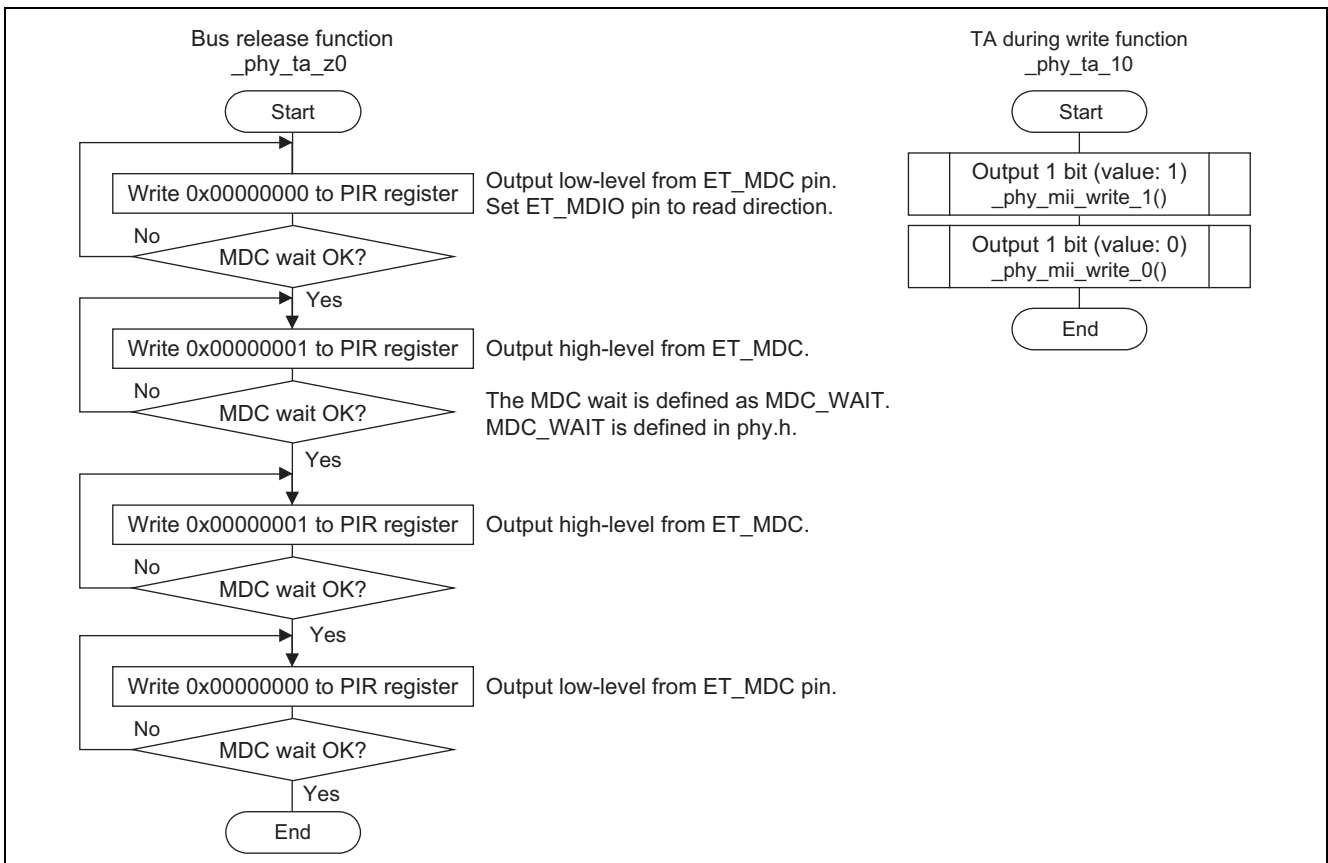

Figure 3.15 Processing Sequence of MII/RMII Register Access (5)

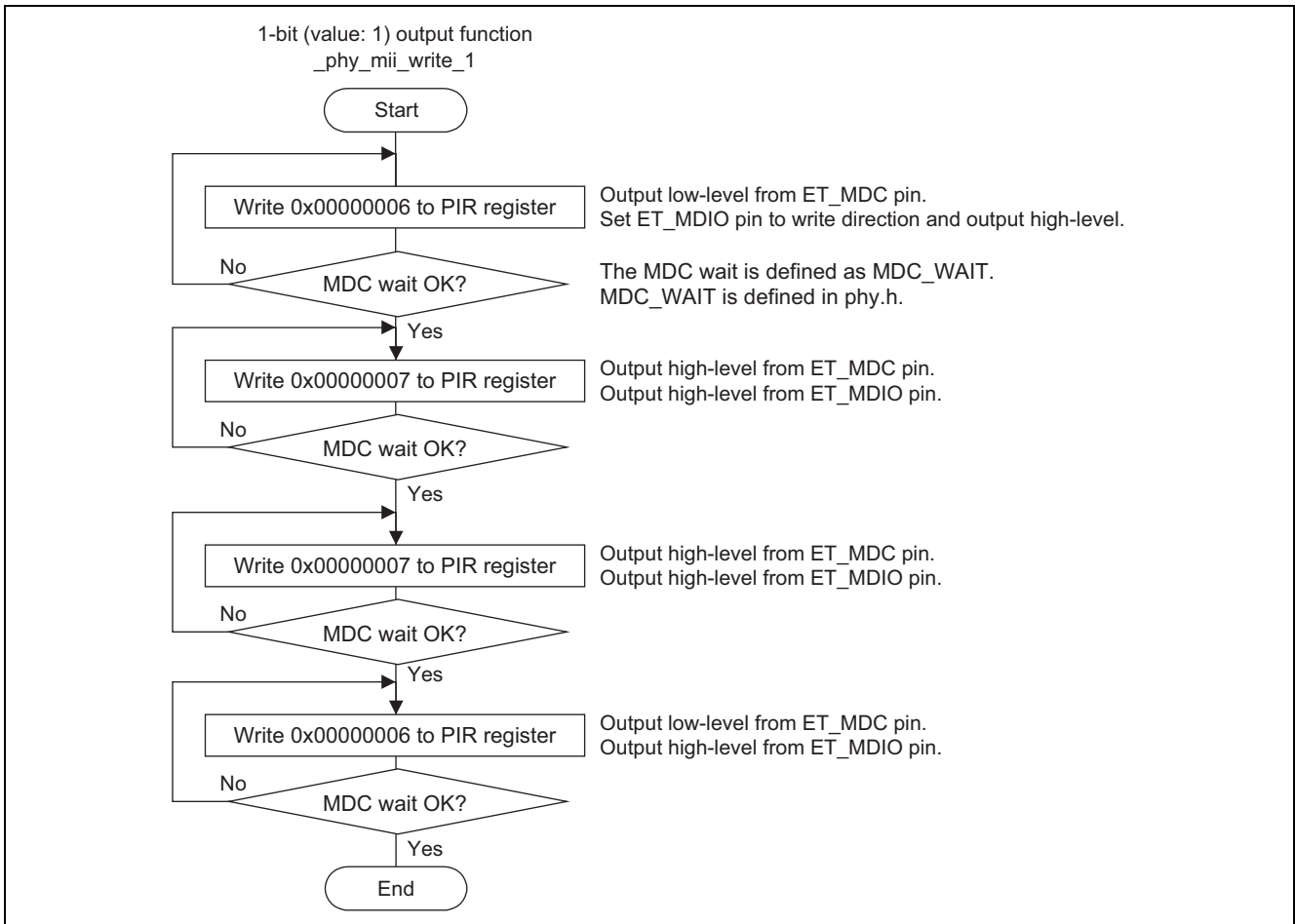

Figure 3.16 Processing Sequence of MII/RMII Register Access (6)

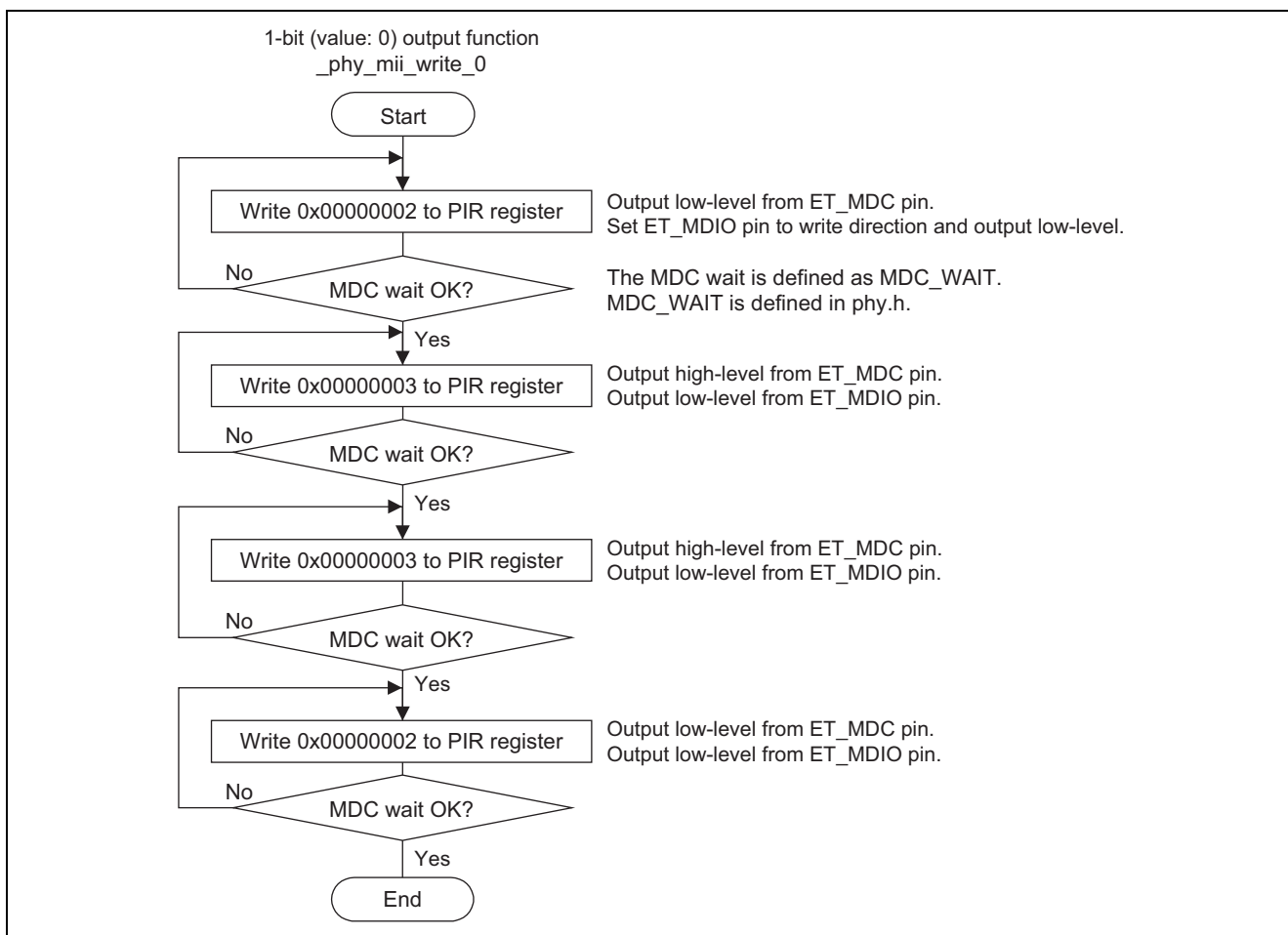

Figure 3.17 Processing Sequence of MII/RMII Register Access (7)

### 3.4 Details of Physical Layer Transceiver (PHY) Auto-Negotiation Settings

Table 3.2 lists the settings used in the sample program.

Table 3.2 Sample Program Settings

Item	Description
PHY model	LAN8700i from Standard Microsystems Corporation
Link modes	100 Mbps (full-duplex, half-duplex) and 10 Mbps (full-duplex, half-duplex)
Link determination method	Auto-negotiation
PHY address	0x1F* <sup>1</sup>
Setting target MII/RMII registers	Register 0 — Basic Control (address: 0x00) Register 1 — Basic Status (address: 0x01) Register 4 — Auto Negotiation Advertisement (address: 0x04) Register 5 — Auto Negotiation Link Partner Ability (address: 0x05)

Note: 1. The setting of the Renesas Starter Kit +(product number: R0K5562N0C000BE) is 0x1F. This must be changed to match the actual PHY address.

### 3.5 Notes on Physical Layer Transceiver (PHY) Auto-Negotiation Settings

- The sample program assumes that auto-negotiation mode is used as the PHY link determination method.
- When the partner device is operating in auto-negotiation mode, the link mode is determined according to the priority levels shown in table 3.3.

Table 3.3 Link Mode Priority Levels

Priority Level		Link Mode
High	1	100 Mbps, full-duplex
	2	100 Mbps, half-duplex
	3	10 Mbps, full-duplex
Low	4	10 Mbps, half-duplex

- The MII/RMII register access timing can be changed by using the following macro definition in the **phy.h** file. Use a setting value of 1 or greater.

```
#define MDC_WAIT 2
```

- The physical layer transceiver (PHY) reset completion wait duration used by the sample program can be changed by using the following macro definition in the **phy.h** file.

```
#define PHY_RESET_WAIT 0x00020000L
```

- Auto-negotiation normally takes a few seconds to complete, but the physical layer transceiver (PHY) auto-negotiation completion wait duration used by the sample program can be changed by using the following macro definition in the **phy.h** file.

```
#define PHY_AUTO_NEGOTIATION_WAIT 0x00800000L
```

- On the Renesas Starter Kit +(product number: R0K5562N0C000BE) the PHY address is set to 0x1F. The PHY address used by the sample program can be changed by using the following macro definition in the **phy.h** file.

```
#define PHY_ADDR 0x1F
```

## 4. Description of Transmit/Receive Settings

The sample program makes use of the Ethernet controller (ETHERC) and Ethernet controller direct memory access controller (EDMAC).

### 4.1 Operation of Functions Used

The RX62N Group always uses the ETHERC and EDMAC to perform Ethernet communication functions. The ETHERC handles transmit and receive control. The EDMAC uses DMA transfer exclusively to move data between the transmit and receive FIFOs and the user-specified data storage destinations (buffers).

#### 4.1.1 Overview of ETHERC

The RX62N Group has an on-chip Ethernet controller (ETHERC) conforming to the Ethernet or IEEE802.3 Media Access Control (MAC) layer standard. Connecting a physical layer transceiver (PHY) complying with this standard enables the ETHERC to perform transmission and reception of Ethernet/IEEE802.3 frames. The ETHERC has one MAC layer interface port. The ETHERC is connected internally to the Ethernet direct memory access controller (EDMAC), enabling high-speed memory access.

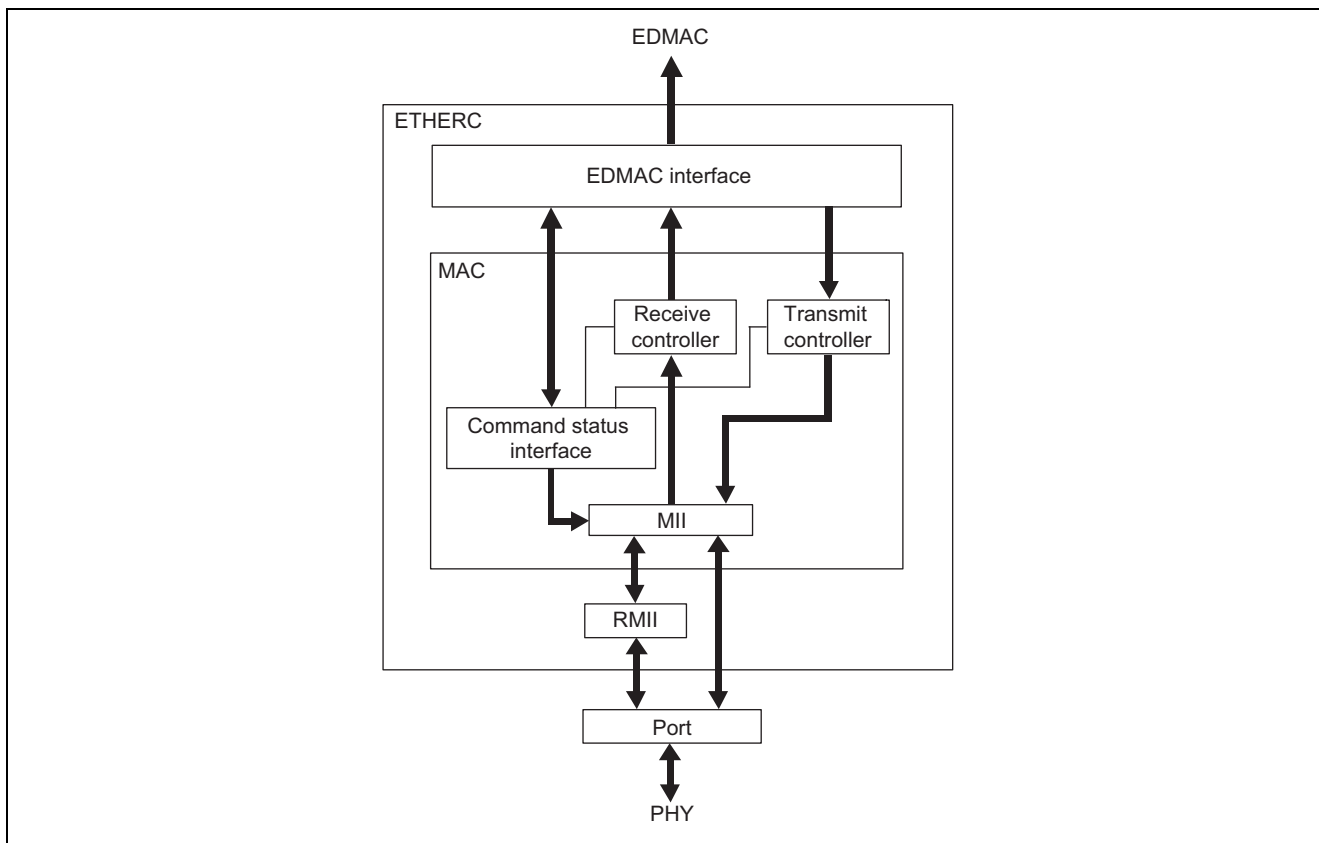

Figure 4.1 Configuration of ETHERC

4.1.2 Overview of ETHERC Transmitter

The ETHERC transmitter assembles transmit data into a frame and outputs it to the MII/RMII when there is a transmit request from the transmit EDMAC. The transmit data is sent to the lines via the MII/RMII by the physical layer transceiver (PHY). Figure 4.2 shows the state transitions of the ETHERC transmitter.

- 1. When the transmit enable (ECMR.TE) bit is set to 1, the transmitter enters the transmit idle state.
- 2. When a transmit request is issued by the transmit EDMAC, the ETHERC sends the preamble to the MII/RMII after carrier detection and a transmission delay equivalent to the frame interval time. If full-duplex transfer, which does not require carrier detection, is selected, the preamble is sent as soon as a transmit request is issued by the transmit EDMAC.
- 3. The transmitter sends the SFD, data, and CRC sequentially. At the end of transmission, the transmit EDMAC generates a transmission complete interrupt (TC). If a collision or the carrier-not-detected state occurs during data transmission, it is reported as an interrupt source.
- 4. After the frame interval time elapses, the transmitter enters the idle state, and if there is more transmit data, continues transmission.

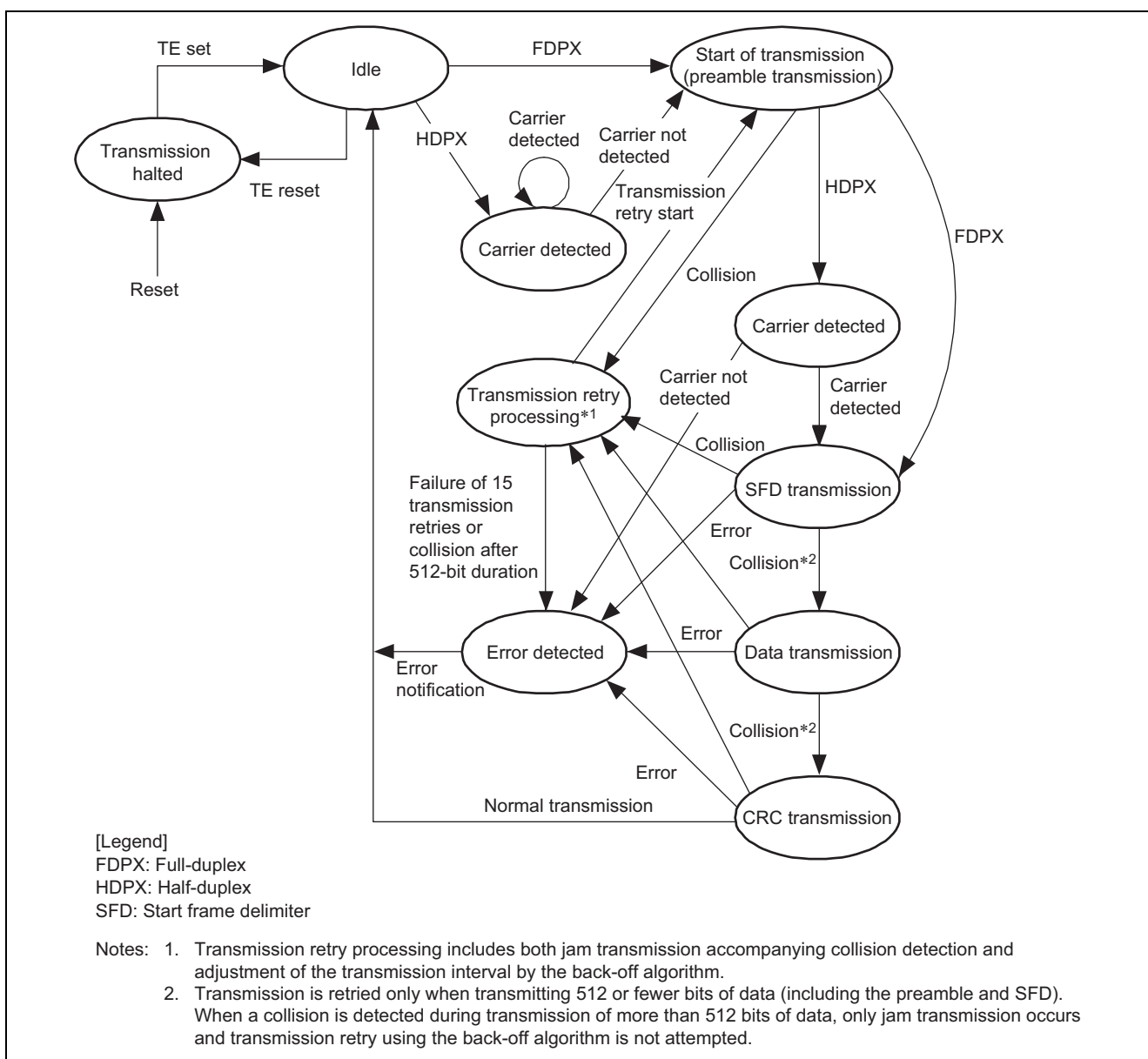

Figure 4.2 ETHERC Transmitter State Transitions

4.1.3 Overview of ETHERC Receiver

The ETHERC receiver divides the frame from the MII/RMII into the preamble, SFD, data, and CRC, and the fields from DA (destination address) to the CRC data are output to the receive EDMAC. Figure 4.3 shows the state transitions of the ETHERC receiver.

- 1. When the receive enable (ECMR.RE) bit is set to 1, the receiver enters the receive idle state.
- 2. Upon detecting an SFD (start frame delimiter) after a receive packet preamble, the receiver starts receive processing. It discards frames with an invalid pattern.
- 3. In normal mode, if the destination address of the frame matches the RX62N address, or if the broadcast or multicast frame type is specified, the receiver starts data reception. In promiscuous mode, the receiver starts reception for any type of frame.
- 4. After receiving data from the MII/RMII, the receiver performs a CRC check on the frame data field. The result is indicated as a status bit in the descriptor after the frame data has been written to memory. The receiver reports an error status in the case of an abnormality.
- 5. After one frame is received, the receiver prepares to receive the next frame if the receive enable bit in the ETHERC mode register is set to 1 (ECMR.RE = 1).

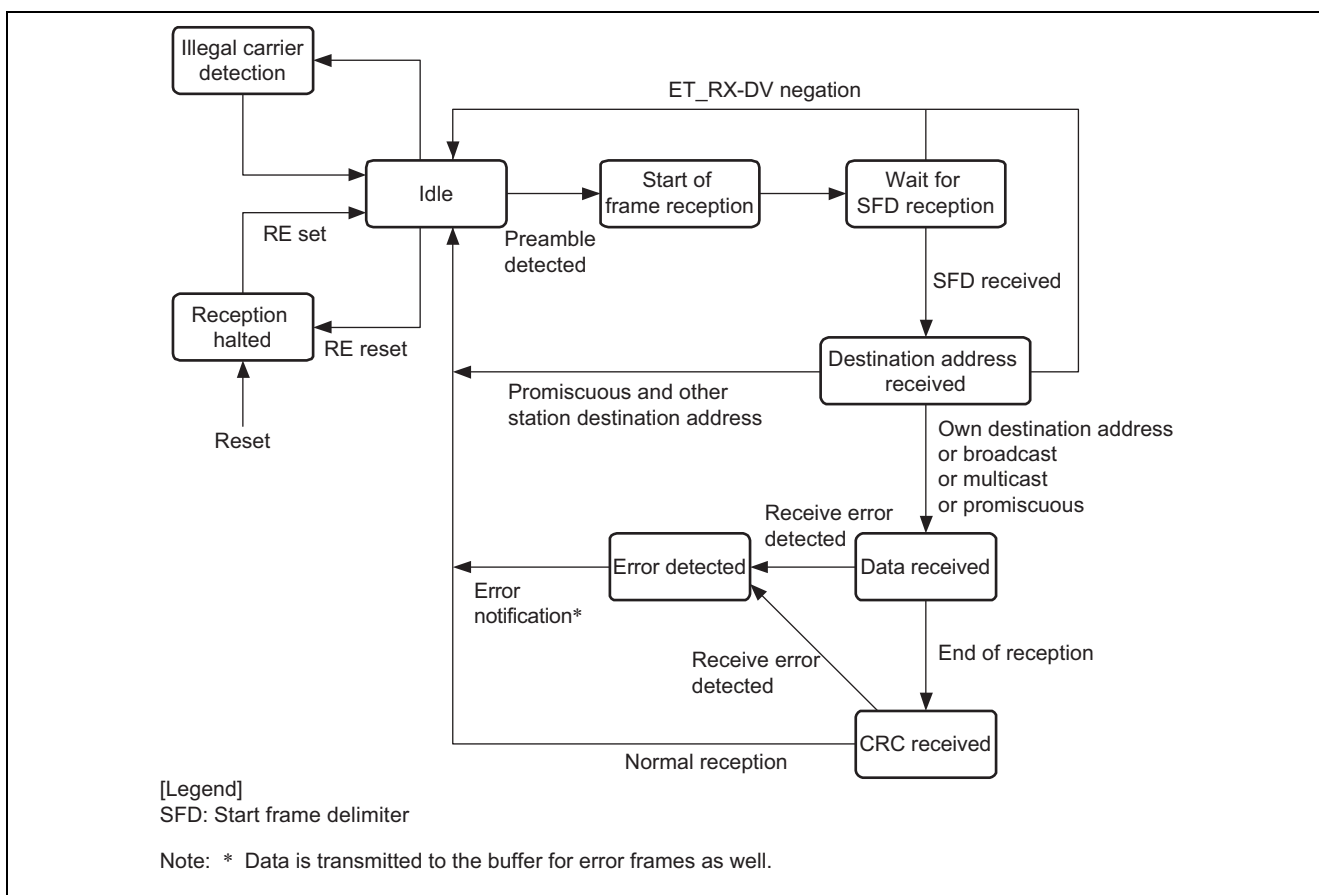

Figure 4.3 Receiver State Transitions

4.1.4 Overview of EDMAC

The RX62N Group has an on-chip direct memory access controller (EDMAC) that is directly connected to the Ethernet controller (ETHERC). Most buffer management is controlled by the EDMAC by using descriptors. This reduces the load on the CPU, enabling efficient data transmission and reception.

The EDMAC is connected to the ETHERC, allowing efficient transfer of transmit and receive data to and from the memory (buffers), bypassing the CPU. The EDMAC itself reads stored control information, such as buffer pointers (called descriptors) that correspond to the individual buffers. Transmit data is read from the transmit buffers, and receive data written to the receive buffers, according to the control information. By arranging multiple descriptors consecutively (in a descriptor list), transmission and reception can be performed continuously.

Table 4.1 lists the EDMAC specifications, and figure 4.4 shows the configuration of the EDMAC and of the descriptors and transmit/receive buffers in memory.

Table 4.1 Specifications of EDMAC

Item	Description
Data transmission and reception	<ul style="list-style-type: none"> <li>• Descriptor management system</li> <li>• Support for single-frame/multi-buffer operation</li> </ul>
Functions	<ul style="list-style-type: none"> <li>• Efficient system bus utilization through use of DMA block transfer (32-byte units)</li> <li>• Indication in descriptors of transmit/receive frame status information</li> <li>• Ability to insert padding in receive data</li> </ul>

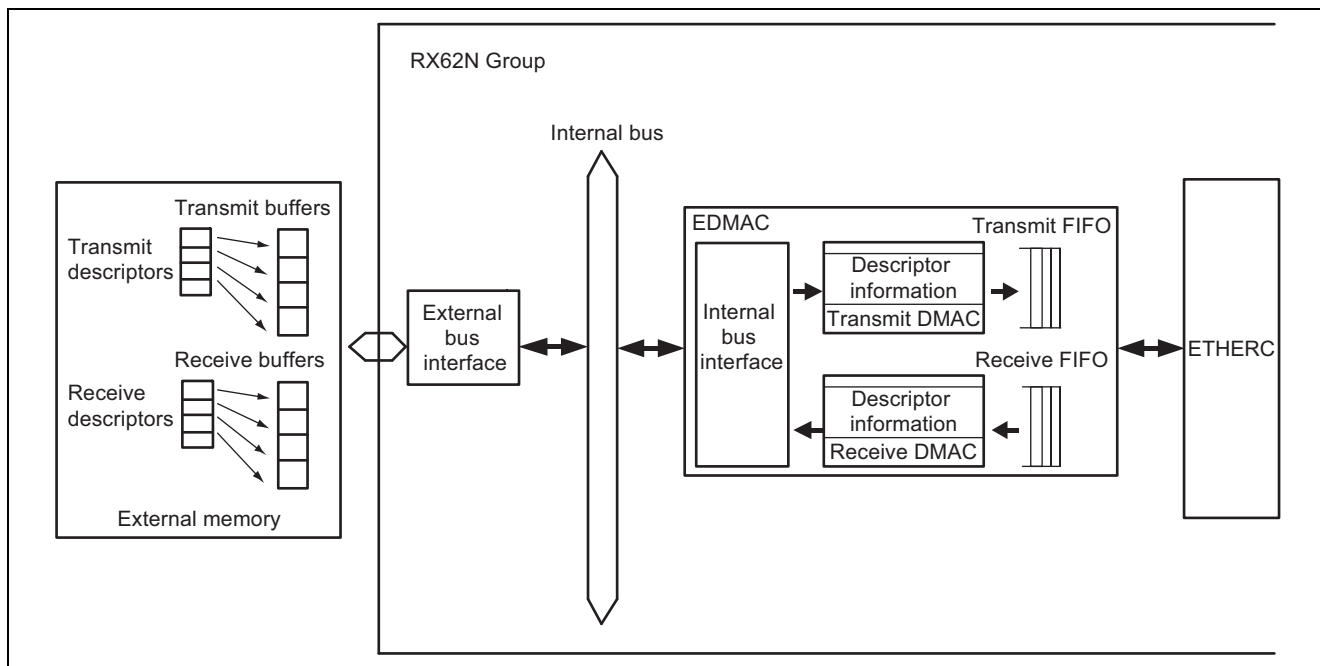

Figure 4.4 Configuration of EDMAC, Descriptors, and Buffers

### 4.1.5 Overview of Descriptors

To perform a DMA transfer, the EDMAC requires a unit of data called a descriptor that contains information such as the storage address of the transmit or receive data. There are two types of descriptors: transmit descriptors and receive descriptors. The EDMAC automatically starts reading a transmit descriptor when the TR bit in the EDMAC transmit request register (EDTRR) is set to 1, and when the RR bit in the EDMAC receive request register (EDRRR) is set to 1 it automatically starts reading a receive descriptor. It is necessary for the user to declare beforehand in the transmit or receive descriptor the appropriate information regarding the DMA transfer of the transmit or receive data. When transmission or reception of an Ethernet frame completes, the EDMAC clears to 0 the descriptor's active bit (TACT for transmission and RACT for reception) and updates the status bits (TFS25 to TFS0 for transmission and RFS26 to RFS0 for reception) to reflect the transmit or receive result.

The descriptors are allocated to a readable memory space, and the address of the start descriptor (the first descriptor read by the EDMAC) is specified in the transmit descriptor list start address register (TDLAR) or receive descriptor list start address register (RDLAR). When preparing multiple descriptors in a descriptor list, allocate the descriptors to consecutive addresses according to the descriptor length specified by the DL bits in the EDMAC mode register (EDMR).

### 4.1.6 Overview of Transmit Descriptor

Figure 4.5 shows the correspondence between a transmit descriptor and a transmit buffer.

A transmit descriptor comprises, beginning from the start of the data, 32-bit units designated TD0, TD1, and TD2, followed by padding. TD0 contains a bit indicating whether the transmit descriptor is active or inactive as well as descriptor configuration information and status information. TD1 indicates the data length (TBL) of the transmit buffer containing the data to be transferred according to the designation of the descriptor. TD2 indicates the start address of the transmit buffer containing the data to be transferred. The length of the padding is determined according to the descriptor length specified by the DL bits in the EDMR register.

Depending on the transmit descriptor settings, one descriptor can specify a single frame of transmit data (single-frame/single-descriptor) or multiple descriptors can specify a single frame of transmit data (single-frame/multi-descriptor). Single-frame/multi-descriptor operation can be used, for example, to set multiple descriptors to specify a fixed portion of data that is transmitted in every Ethernet frame. Specifically, the data in each Ethernet frame specifying the destination address and transmit source address could be shared in common by multiple descriptors and the remaining data stored in its own buffer.

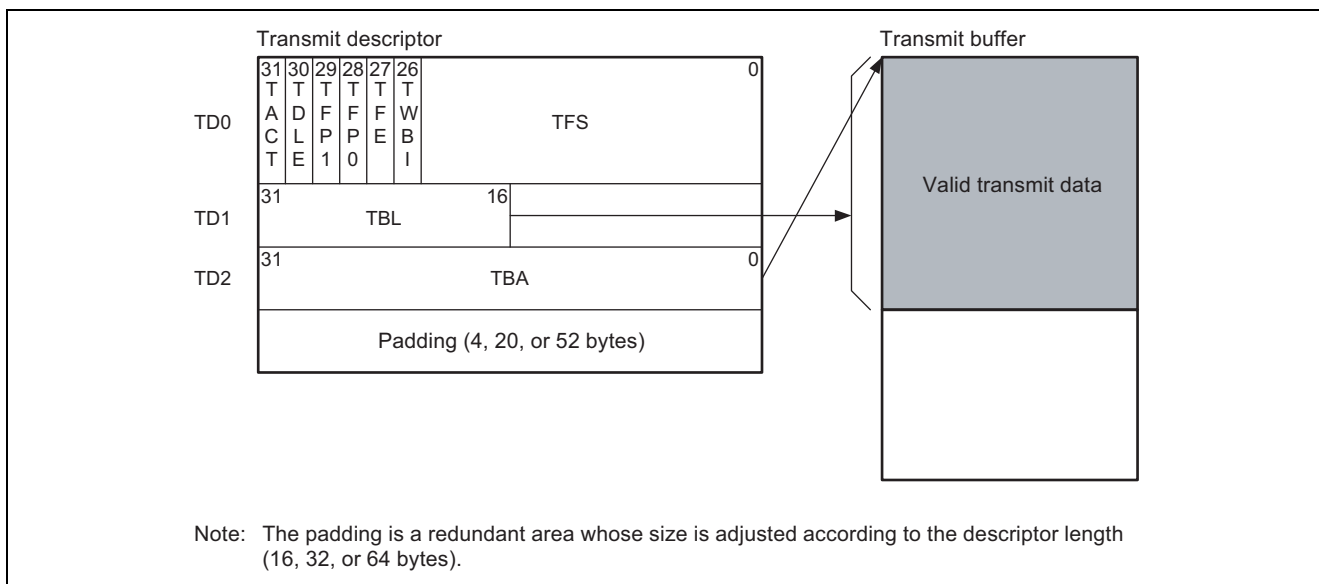

Figure 4.5 Correspondence of Transmit Descriptor and Transmit Buffer

4.1.7 Overview of Receive Descriptor

Figure 4.6 shows the correspondence between a receive descriptor and a receive buffer.

A receive descriptor comprises, beginning from the start of the data, 32-bit units designated RD0, RD1, and RD2, followed by padding. RD0 contains a bit indicating whether the receive descriptor is active or inactive as well as descriptor configuration information and status information. RD1 indicates the size (RBL) of the receive buffer referenced by the descriptor and the data length (RFL) of the received frame. RD2 indicates the start address of the receive buffer. The length of the padding at the end is determined according to the descriptor length specified by the DL bits in the EDMR register.

Depending on the receive descriptor settings, one descriptor can be used to store all the receive data in a single frame in a receive buffer (single-frame/single-descriptor) or multiple descriptors can be used to store the receive data in a single frame to multiple buffers (single-frame/multi-descriptor). To use single-frame/multi-descriptor operation, multiple descriptors (a descriptor list) must be prepared beforehand. When the length of a received frame exceeds the descriptor RBL, the EDMAC transfers the data it contains to consecutive receive buffers, continuing on to the next descriptor as necessary. This would apply, for example, when the descriptor RBL is set to 500 bytes and a 1,514-byte Ethernet frame is received. Beginning from the first descriptor, the data in the received Ethernet frame is saved 500 bytes at a time to successive buffers, with only the final 14 bytes transferred to the fourth buffer.

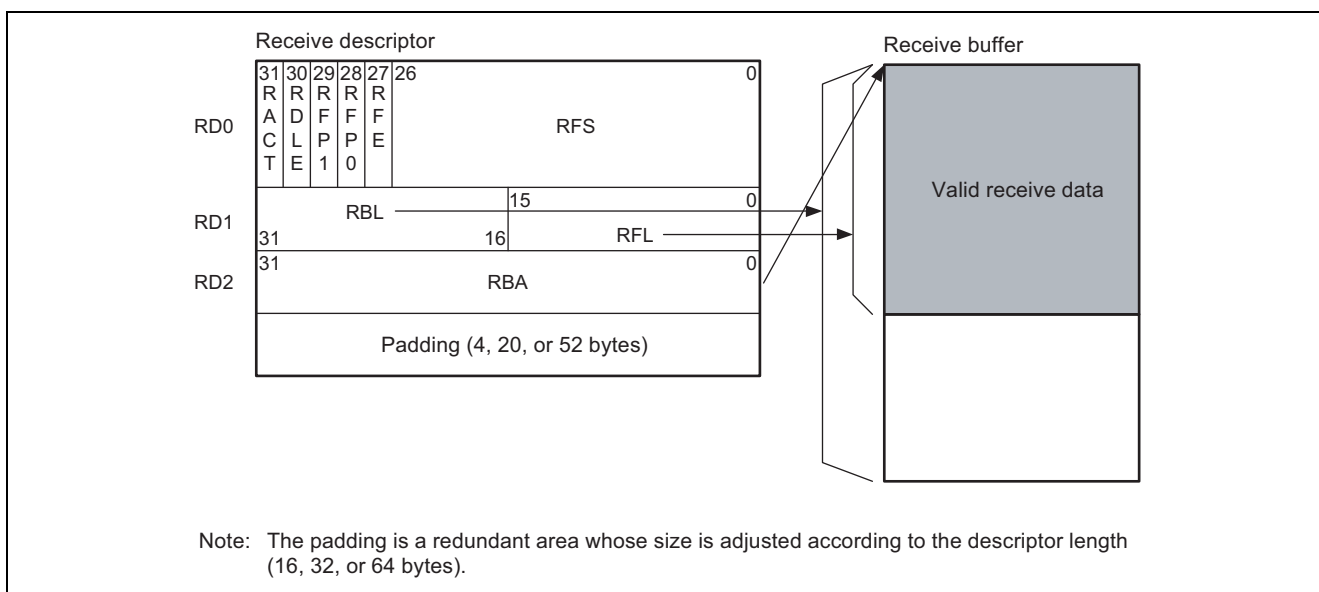

Figure 4.6 Correspondence of Receive Descriptor and Receive Buffer

4.1.8 Transmit Descriptor Setting Example

Figure 4.7 shows an example in which three transmit descriptor planes and three transmit buffer planes are used (single-frame/single-descriptor). In this case, one frame only is transmitted by a single transmit request. The figure is abbreviated to show only the TD0 portion of each transmit descriptor. The numbers (1), (2), etc., in the figure indicate the execution sequence.

Settings are performed as follows.

- 1. Since single-frame/single-descriptor operation is used, the TFP1 and TFP0 bits in all the descriptor planes are set to B'11.
- 2. Bits TACT, TFE, TWBL, and TFS25 to TFS0 in all the descriptor planes are cleared to 0 as the initial value.
- 3. The TDLE bit in the first and second descriptor planes is cleared to 0. The TDLE bit in the third descriptor plane is set to 1, which causes the first descriptor plane to be read after processing of the third descriptor plane completes. These settings enable the descriptors to function in a ring configuration.
- 4. Though omitted from figure 4.7, the data length of the transmit buffer referenced by each descriptor is specified by the TBL bits and the transmit buffer start address by the TBA bits.
- 5. One frame only is transmitted by a single transmit request in this example, so the TACT bit of the first descriptor plane only is set to 1 for the initial transmission. For the next transmission, the TACT bit of the second descriptor plane only is set to 1. The transmission procedure is described in more detail in 4.1.10, Function Operating Procedure (Transmission).

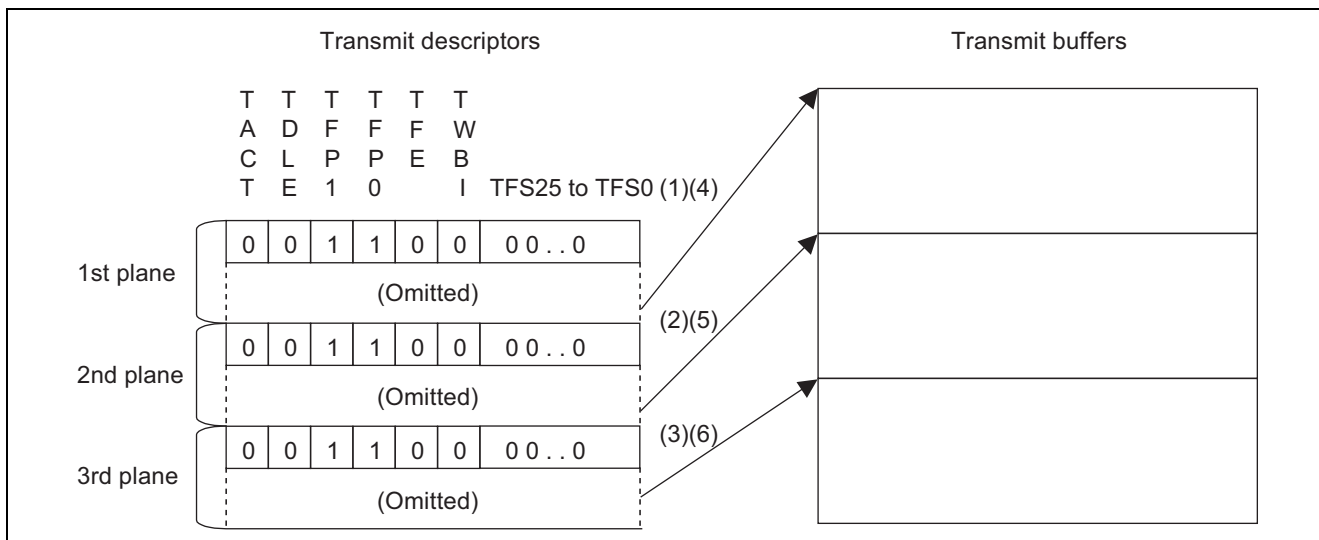

Figure 4.7 Correspondence of Transmit Descriptors and Transmit Buffers

4.1.9 Receive Descriptor Setting Example

Figure 4.8 shows an example in which three receive descriptor planes and three receive buffer planes are used. Each receive buffer can accommodate 1,536 bytes, and single-frame/single-descriptor operation is used. The figure is abbreviated to show only the RD0 portion of each receive descriptor. The numbers (1), (2), etc., in the figure indicate the execution sequence.

Settings are performed as follows.

- 1. Bits RFP1, RFP0, RFE, and RFS26 to RFS0 in all the descriptor planes are cleared to 0.
- 2. The RDLE bit in the first and second descriptor planes is cleared to 0. The RDLE bit in the third descriptor plane is set to 1, which causes the first descriptor plane to be read after processing of the third descriptor plane completes. These settings enable the descriptors to function in a ring configuration.
- 3. Though omitted from figure 4.8, before reception starts the receive buffer size is set to 1,536 bytes by the RBL bits in RD1 of all the descriptor planes, and the receive buffer start address is specified by the RBA bits in RD2.
- 4. The RACT bit of all the descriptor planes is set to 1 for continuous reception. The reception procedure is described in more detail in 4.1.11, Function Operating Procedure (Reception).

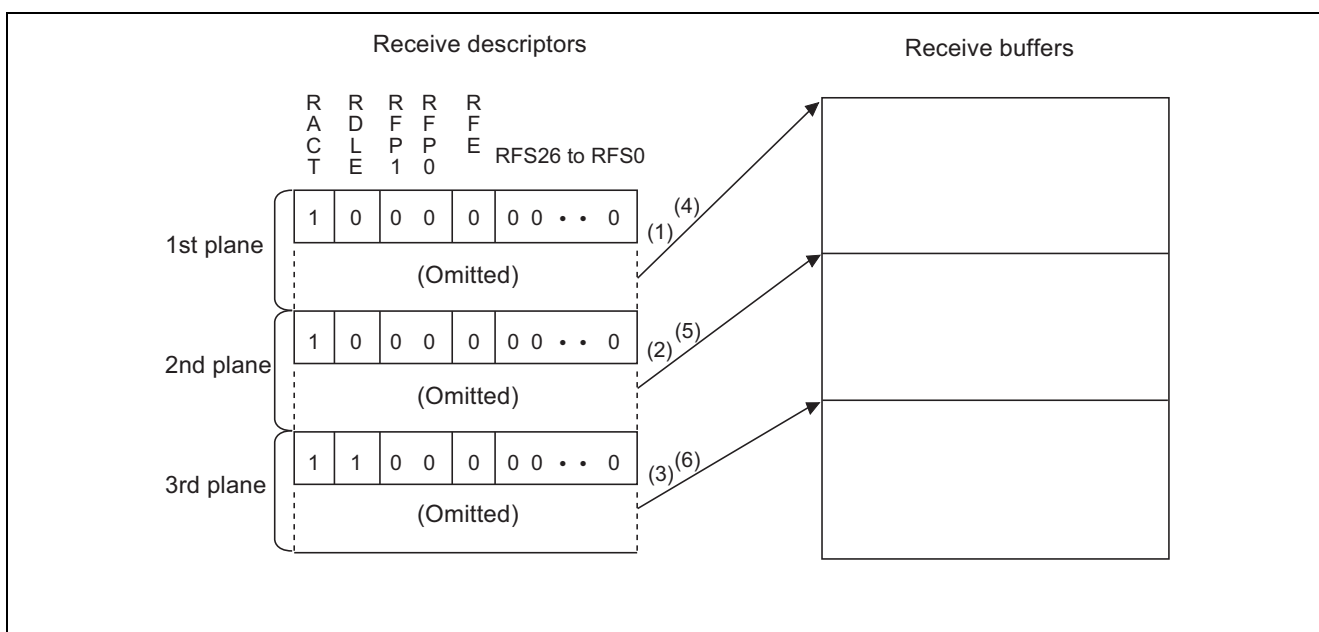

Figure 4.8 Correspondence of Receive Descriptors and Receive Buffers

4.1.10 Function Operating Procedure (Transmission)

The EDMAC transmitter is activated when the transmit request (TR) bit in the EDMAC transmit request register (EDTRR) is set to 1 while the value of the TE bit in the ETHERC mode register (ECMR) is 1. After a software reset of the ETHERC and EDMAC, the EDMAC reads the descriptor indicated by the transmit descriptor list start address register (TDLAR). If the TACT bit of the descriptor that was read is set to 1 (active), the EDMAC sequentially reads transmit frame data from the transmit buffer start address specified by TD2 for transfer to the ETHERC. The ETHERC creates a transmit frame and starts transmission to the MII/RMII. After DMA transfer of data equivalent to the buffer length specified in the descriptor, the processing described below is carried out according to the value of TFP.

- TFP = B'00 or B'10 (frame continuation)  
 Descriptor write-back (writing 0 to the TACT bit) is performed after DMA transfer. Then the TACT bit of the next descriptor is read.
- TFP = B'01 or B'11 (frame end)  
 Descriptor write-back (writing 0 to the TACT bit and status bits) is performed after completion of frame transmission. Then the TACT bit of the next descriptor is read.

When the TACT bit of the descriptor that was read is set to 1 (active), frame transmission continues and the next descriptor is read. When a descriptor with the TACT bit cleared to 0 (inactive) is read, the EDMAC clears the TR bit in EDTRR to 0 and transmit processing completes. Setting the TR bit to 1 after it has been cleared to 0 reactivates the EDMAC transmitter, and in this case the next descriptor after the descriptor from the last transmission is read. Figure 4.9 shows a sample transmission sequence.

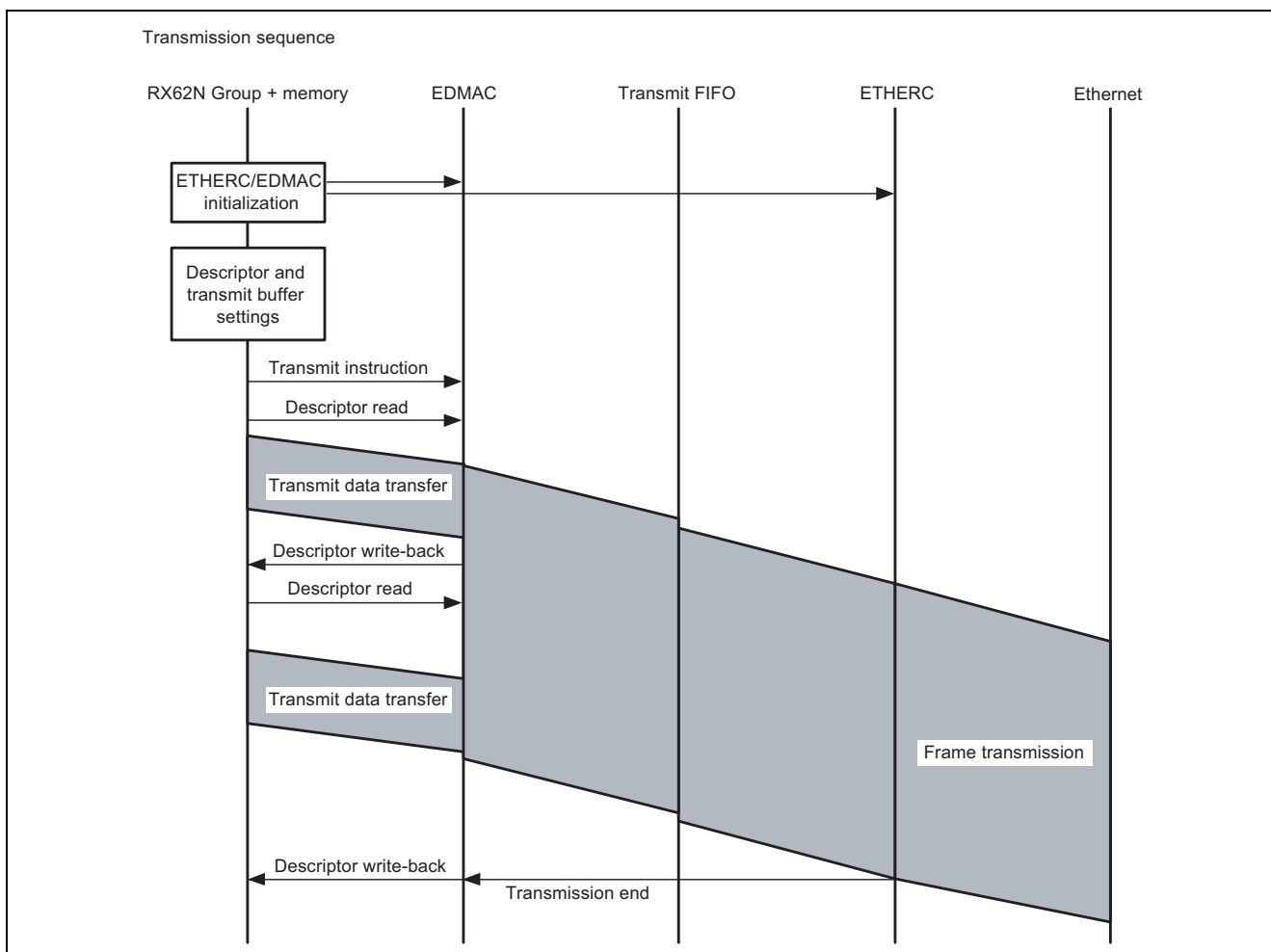

Figure 4.9 Sample Transmission Sequence

4.1.11 Function Operating Procedure (Reception)

The EDMAC receiver is activated when the receive request (RR) bit in the EDMAC receive request register (EDRRR) is set to 1 while the value of the RE bit in ECMR is 1. After a software reset of the ETHERC and EDMAC, the EDMAC reads the descriptor indicated by the receive descriptor list start address register (RDLAR) and, if the RACT bit is set to 1 (active), enters the receive standby state. When the ETHERC receives a frame for a local destination (an address for which local reception is enabled), it stores it in the receive FIFO. If the value of the RACT bit in the receive descriptor is 1, the EDMAC transfers the frame to the receive buffer specified by RD2. (If the value of the RACT bit is 0 (inactive), the RR bit is cleared to 0 and EDMAC receive operation stops.) If the data length of a received frame is longer than the buffer length specified by RD1, the EDMAC performs a write-back operation to the descriptor (RFP = B'10 or B'00) when the buffer becomes full, then reads the next descriptor. When frame reception is completed, or if frame reception is aborted because of an error, the EDMAC performs write-back to the relevant descriptor (RFP = B'11 or B'01).

When continuous reception is selected (receive request bit reset (RNR) bit in receiving method control register (RMCR) set to 1), the EDMAC reads the next descriptor and, if the RACT bit is set to 1, enters the receive standby state. When continuous reception is selected, setting the receive request bit non-reset mode (RNC) bit in the RMCR register to 1 causes EDMAC receive operation to continue, with no clearing of the RR bit even if the RACT bit is cleared to 0 (inactive). (Receive descriptors are fetched consecutively, and receive frame DMA continues.) When continuous reception is not selected (value of RNR bit in RMCR register is 0), the RR bit in the EDRRR register is cleared to 0 and EDMAC receive operation ends. Setting the RR bit to 1 once again causes the EDMAC to read the next descriptor after the descriptor from the last receive operation and then enter the receive standby state.

Figure 4.10 shows a sample reception sequence.

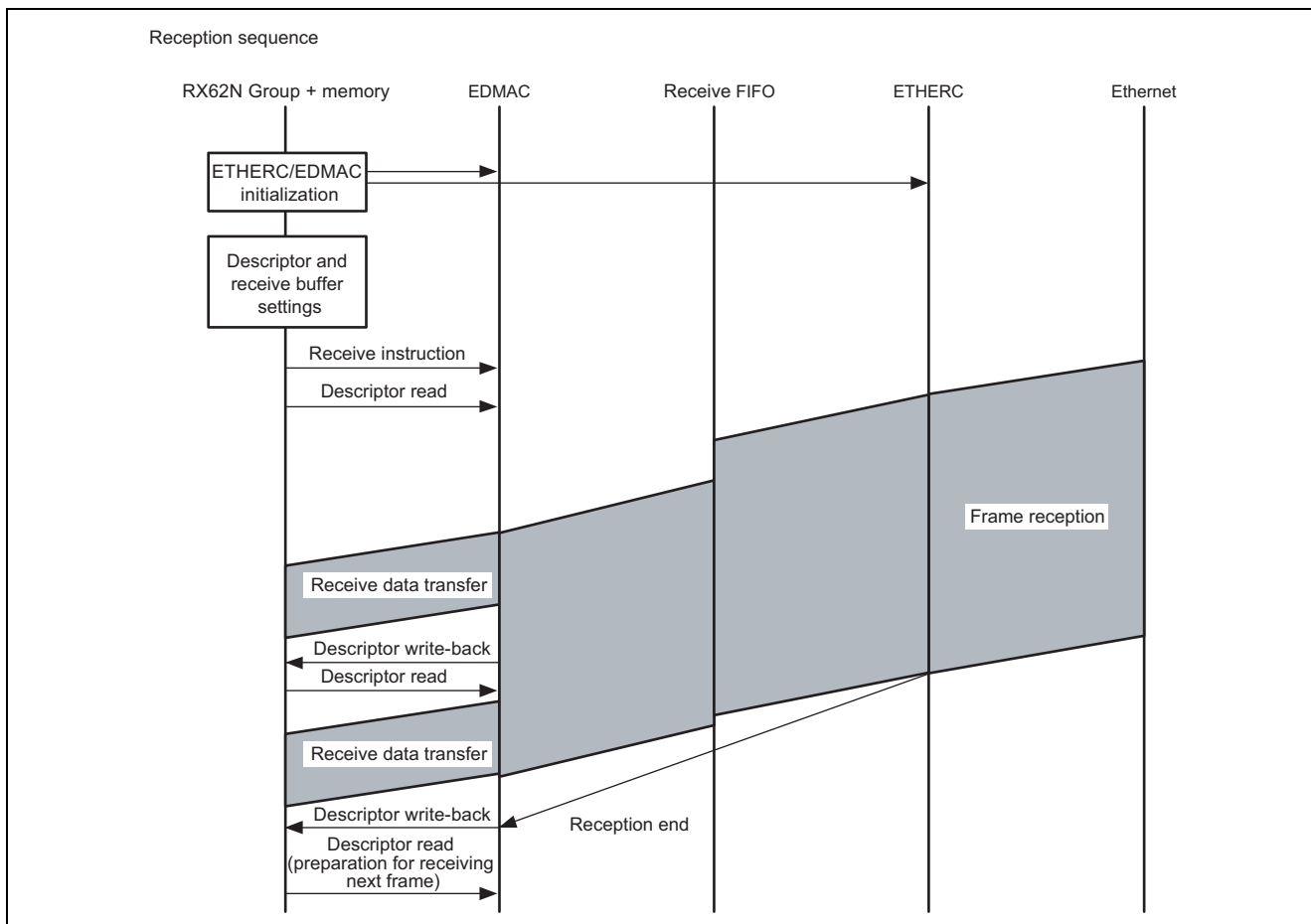

Figure 4.10 Sample Reception Sequence (Single-Frame/Single-Descriptor)

4.1.12 Function Operating Procedure (Transmission/Reception)

The basic settings needed for Ethernet transmission and reception are described below. Figures 4.11 to 4.13 show sample Ethernet transmit/receive setting sequences.

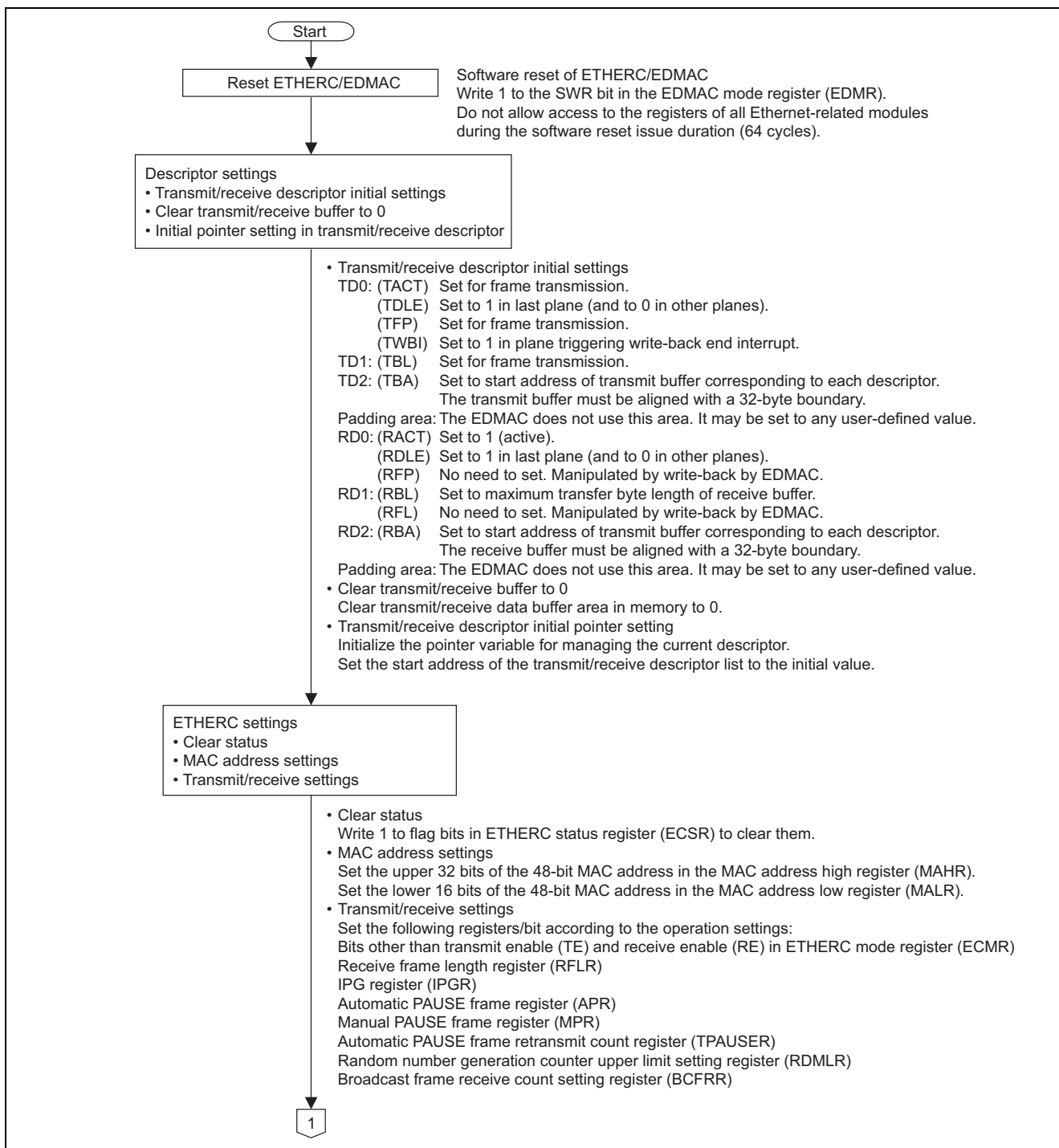

Figure 4.11 Sample Ethernet Transmit/Receive Setting Sequence (1)

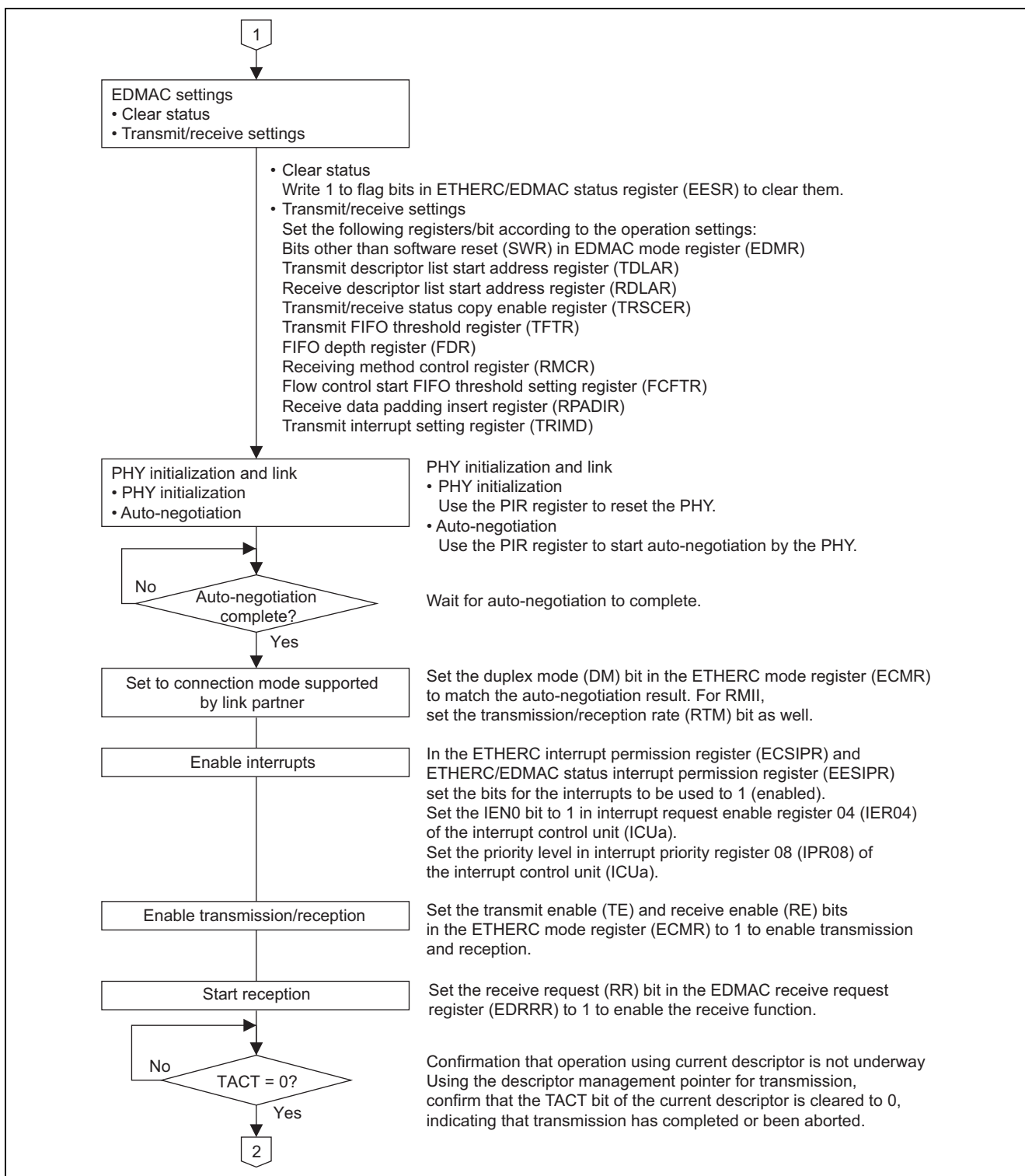

Figure 4.12 Sample Ethernet Transmit/Receive Setting Sequence (2)

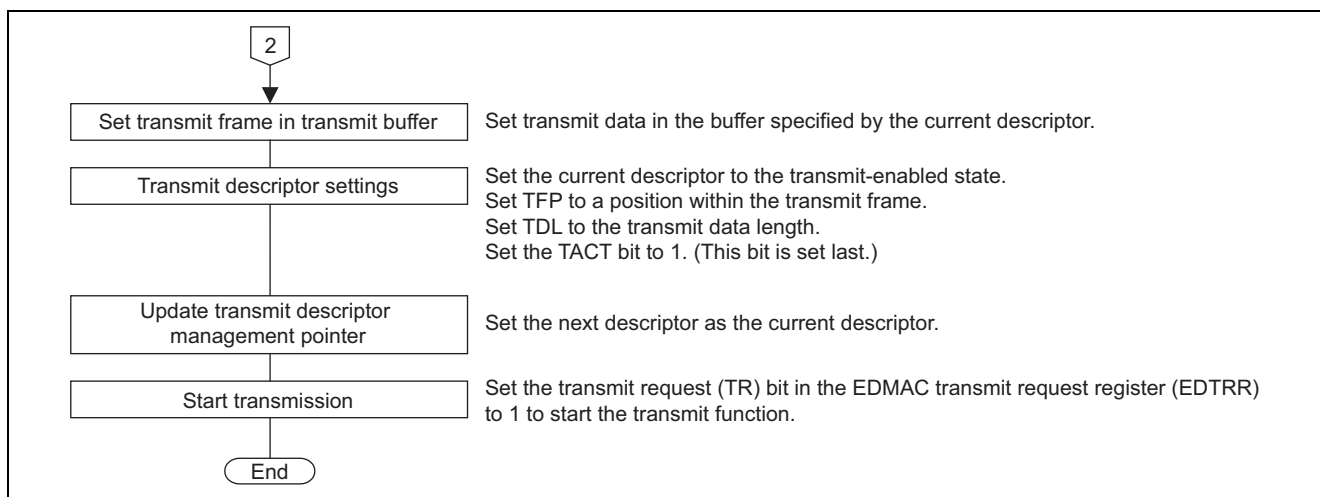

Figure 4.13 Sample Ethernet Transmit/Receive Setting Sequence (3)

## 4.2 Operation of Sample Program

The sample program performs one of the two tasks listed below according to the test type selected in the main routine. In both cases, the same settings are used for the Ethernet initial state.

- Transmission of 10 Ethernet frames
- Reception of 10 Ethernet frames

### 4.2.1 Operation of Sample Program (Transmission)

When the transmission test is selected, the sample program uses the ETHERC and EDMAC to transmit 10 frames to the partner host.

Eight transmit descriptor planes and eight 1,536-byte transmit buffer planes are prepared. The transmit descriptors are put into a linked state for use.

After writing 10 frames worth of transmit data to the transmit buffer, the sample program uses the transmit request (TR) bit in the EDMAC transmit request register (EDTRR) to determine when transmission of the 10 frames is complete, then ends the transmission test.

### 4.2.2 Operation of Sample Program (Reception)

When the reception test is selected, the sample program uses the ETHERC and EDMAC to receive 10 frames from the partner host.

Eight receive descriptor planes and eight 1,536-byte receive buffer planes are prepared. The receive request bit reset (RNR) bit in the receiving method control register (RMCR) is set to 1 to enable continuous reception.

The sample program checks the RFE bit in the receive descriptor (bit 27 in RD0) and, if there is no error (RFE = 0), copies 1 frame of data from the receive buffer to the user buffer. Then it initializes the relevant descriptor to prepare for the next transmission. If an error has occurred (RFE = 1), the sample program just initializes the relevant descriptor but does not copy a frame to the user buffer. Note that the data transferred to the receive buffer consists of the portion of the Ethernet frame other than the preamble, SFD, and CRC.

4.2.3 Operating Environment of Sample Program

Figure 4.14 shows the operating environment of the sample program. For points to be borne in mind with regard to the operating environment, see 4.6.1, Notes on Operating Environment.

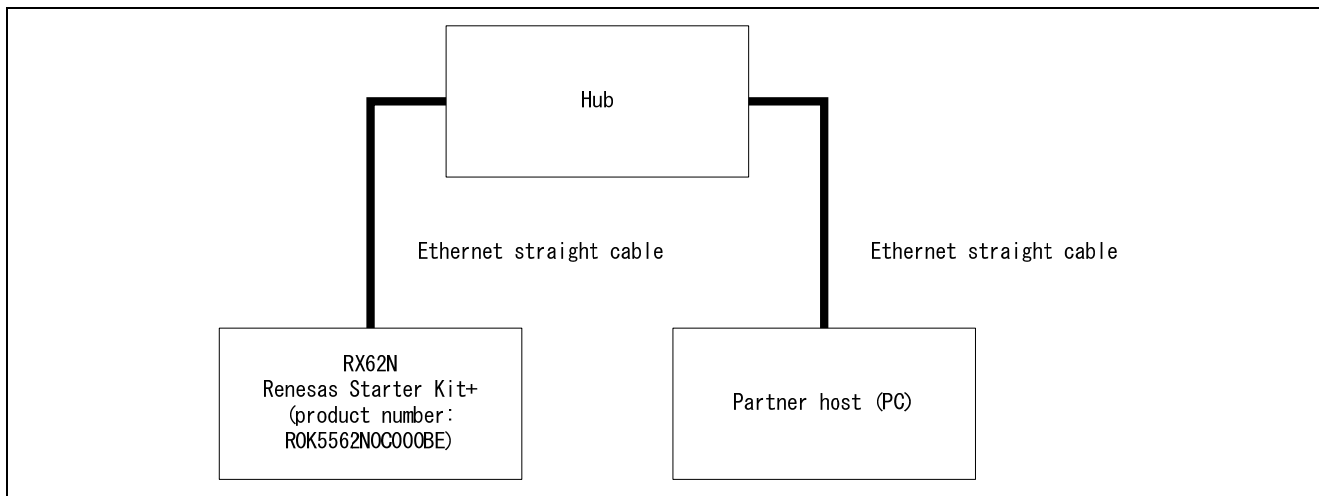

Figure 4.14 Operating Environment of Sample Program

4.2.4 Ethernet Frame Format

The transmit data that must be prepared consists of the portion of the Ethernet frame other than the preamble, start frame delimiter (SFD), and CRC. The destination MAC address and transmit source MAC address in the header must be changed to match the MAC addresses of the devices used. Note that the ETHERC does not check the transmit source MAC address.

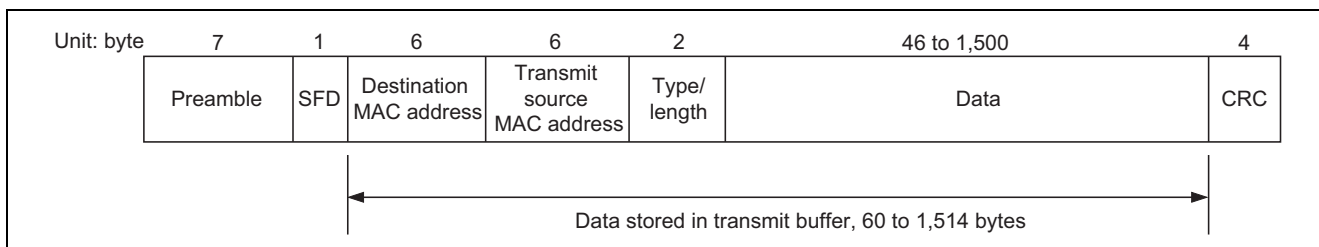

Figure 4.15 Ethernet Frame Format (Transmission)

The data transferred to the receive buffer consists of the portion of the Ethernet frame other than the preamble, SFD, and CRC.

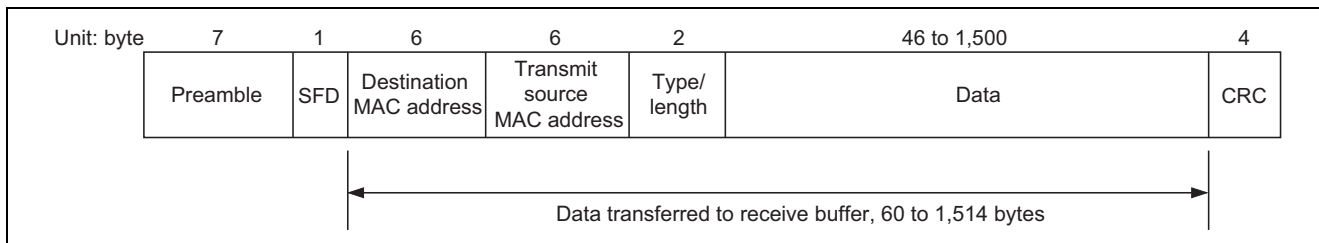

Figure 4.16 Ethernet Frame Format (Reception)

### 4.3 Descriptor Definition in Sample Program

The EDMAC does not use the padding area of the descriptor. It can be used freely by the user. The sample program uses this area to specify the start address of the next descriptor, creating a linked structure in software.

Figure 4.17 shows the transmit and receive descriptors, and the buffers, used by the sample program.

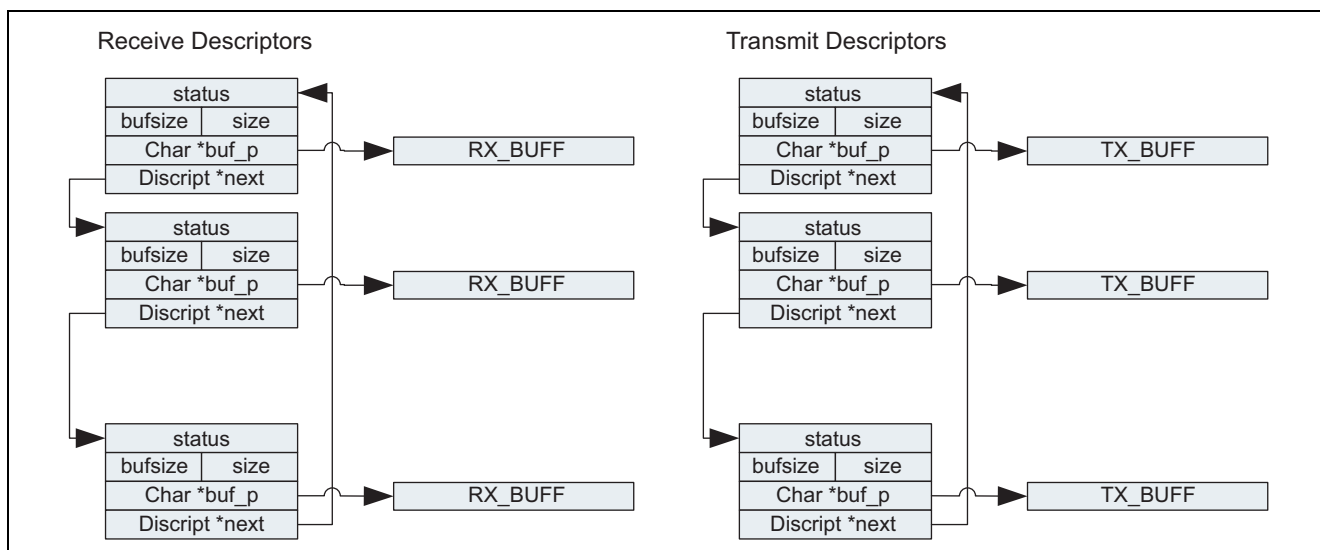

Figure 4.17 Transmit and Receive Descriptors, and Buffers

The descriptors comprise the transmit descriptors TD0, TD1, and TD2, which are 32-bit units, and the receive descriptors RD0, RD1, and RD2, which are also 32-bit units. The sample program defines RBL, the upper 16 bits of the 32-bit unit RD1 (TBL, the upper 16 bits of the 32-bit unit TD1), as the structure member **bufsize**, and the lower 16 bits of RD1 as the structure member **size**. The other 32-bit units are defined as members of 32-bit size.

When allocated in the RAM, the descriptors operate according to the endian setting of the bus. (The on-chip RAM uses the endian mode of the CPU.) The EDMAC accesses the descriptors in 32-bit units. Therefore, **bufsize** and **size** must be allocated in the RAM according to the conditions below to ensure that their contents match when accessed in 32-bit or 16-bit units. No such conditions apply to the other members because they are defined as 32-bit size.

- When the RAM to which a descriptor is allocated is set to big-endian mode  
Set the address allocation of the 32-bit unit RD1 (TD1) such that the member **bufsize** defined for the upper 16 bits is assigned the low-order address and the member **size** defined for the lower 16 bits is assigned the high-order address.
- When the RAM to which a descriptor is allocated is set to little-endian mode  
Set the address allocation of the 32-bit unit RD1 (TD1) such that the member **bufsize** defined for the upper 16 bits is assigned the high-order address and the member **size** defined for the lower 16 bits is assigned the low-order address.

The descriptors of the sample program are defined as structures using macros defined by the compiler, as described below.

```
struct Descriptor
{
    __evenaccess uint32_t    status;
#if __LIT
    __evenaccess uint16_t    size;
    __evenaccess uint16_t    bufsize;
#else
    __evenaccess uint16_t    bufsize;
    __evenaccess uint16_t    size;
#endif
    int8_t                    *buf_p;
    struct Descriptor        *next;
};
```

It is possible to change the number of descriptors and the buffer size by changing the macros below, which are defined in **r\_ether.h**. BUFSIZE specifies the size of the receive buffers (RX\_BUFF) and transmit buffers (TX\_BUFF), and ENTRY specifies the number of descriptors.

The buffers must align with a 32-byte boundary, so the value defined by BUFSIZE in the **r\_ether.h** file assures a 32-byte aligned value in RAM.

```
#define BUFSIZE    1536
#define ENTRY      8
```

## 4.4 Ethernet Driver API

The functions below are provided as TCP/IP stack driver interfaces. They compose the standard Renesas API (RAPI) for Renesas Ethernet devices.

- R\_Ether\_Open
- R\_Ether\_Close
- R\_Ether\_Read
- R\_Ether\_Write
- R\_Ether\_Write\_Sync

### 4.4.1 R\_Ether\_Open

The R\_Ether\_Open function initializes the ETHERC, EDMAC, physical layer transceiver (PHY), and transmit/receive data buffers. The initialization of the ETHERC and EDMAC is separate from the power-on reset.

- Prototype  
`int32_t R_Ether_Open(uint32_t ch, uint8_t mac_addr[]);`
- Arguments
  - ch  
ETHERC channel number specification
  - mac\_addr  
ETHERC MAC address specification
- Return values  
R\_ETHER\_OK(0): Normal completion  
R\_ETHER\_ERROR(-1): Error
- Properties  
Declared in `r_ether.h` file  
Defined in `r_ether.c` file
- Description  
The R\_Ether\_Open function initializes the ETHERC and EDMAC. It sets the EDMAC descriptors and buffers to their initial state. The MAC address is used to initialize the MAC address register of the ETHERC. The initial settings specify auto-negotiation mode for the physical layer transceiver (PHY).  
The RX62N has only one Ethernet channel, so Ethernet driver processing does not branch according to the channel number. The function will operate normally regardless of the channel number value, but setting the channel number to 0 is recommended.  
The Ethernet driver of the RX62N does not include code for processing when the MAC address is set to 0. Therefore, make sure to input a value other than 0 as the MAC address, or add appropriate program code for processing when the MAC address is set to 0.

#### 4.4.2 R\_Ether\_Close

The `R_Ether_Close` function disables the transmit and receive functions of the ETHERC. This function does not power-down the ETHERC and EDMAC.

- Prototype  
`int32_t R_Ether_Close(uint32_t ch);`
- Arguments  
— `ch`  
ETHERC channel number specification
- Return values  
`R_ETHER_OK(0)`: Normal completion  
`R_ETHER_ERROR(-1)`: Error
- Properties  
Declared in `r_ether.h` file  
Defined in `r_ether.c` file
- Description  
The `R_Ether_Close` function disables the transmit and receive functions of the ETHERC.  
The RX62N has only one Ethernet channel, so Ethernet driver processing does not branch according to the channel number. The function will operate normally regardless of the channel number value, but setting the channel number to 0 is recommended.

#### 4.4.3 R\_Ether\_Read

The `R_Ether_Read` function receives data to the application's receive buffer.

- Prototype  
`int32_t R_Ether_Read(uint32_t ch, void *buf);`
- Arguments  
— `ch`  
ETHERC channel number specification  
— `*buf`  
Receive data buffer pointer
- Return values  
Value of 0 or greater: Number of bytes received. 0 indicates no receive data.  
`R_ETHER_ERROR(-1)`: Error (Covers both hardware and software errors.)  
`R_ETHER_HARD_ERROR(-3)`: Hardware error (Software reset required to recover.)  
`R_ETHER_RECOVERABLE(-4)`: Recoverable error (Software reset not required to recover.)  
`R_ETHER_NODATA(-5)`: No receive data

Note: The sample program does not use the `R_ETHER_HARD_ERROR(-3)`, `R_ETHER_RECOVERABLE(-4)`, and `R_ETHER_NODATA(-5)` return values.

- Properties  
Declared in `r_ether.h` file  
Defined in `r_ether.c` file
- Description  
The `R_Ether_Read` function reads data from the buffer designated by the receive descriptor. The receive descriptor status is updated each time new data is processed. After reading the data, the function copies it to the receive data buffer.  
The RX62N has only one Ethernet channel, so Ethernet driver processing does not branch according to the channel number. The function will operate normally regardless of the channel number value, but setting the channel number to 0 is recommended.  
The data associated with a descriptor that generates a receive frame error is discarded, the status is cleared, and read operation continues.

#### 4.4.4 R\_Ether\_Write

The R\_Ether\_Write function transmits data from the application's transmit buffer.

- Prototype  
int32\_t R\_Ether\_Write(uint32\_t ch, void \*buf, uint32\_t len);
- Arguments
  - ch  
ETHERC channel number specification
  - \*buf  
Pointer to Ethernet data to be transmitted
  - len  
Ethernet frame length
- Return values  
R\_ETHER\_OK(0): Normal completion  
R\_ETHER\_ERROR(-1): Error
- Properties  
Declared in **r\_ether.h** file  
Defined in **r\_ether.c** file
- Description  
The R\_Ether\_Write function writes transmit data to the buffer designated by the transmit descriptor. The transmit descriptor status is updated each time new data is processed. After the data is written, it is transmitted by the ETHERC.  
The R\_Ether\_Write function does not check transmit completion.  
The RX62N has only one Ethernet channel, so Ethernet driver processing does not branch according to the channel number. The function will operate normally regardless of the channel number value, but setting the channel number to 0 is recommended.  
The function does not check for transmit frame errors.

#### 4.4.5 R\_Ether\_Write\_Sync

The R\_Ether\_Write\_Sync function writes transmit data to the transmit buffer and waits for data transmission to complete.

- Prototype  
int32\_t R\_Ether\_Write\_Sync(uint32\_t ch, void \*buf, uint32\_t len);
- Arguments
  - ch  
ETHERC channel number specification
  - \*buf  
Pointer to Ethernet data to be transmitted
  - len  
Ethernet frame length
- Return values  
R\_ETHER\_OK(0): Normal completion  
R\_ETHER\_ERROR(-1): Error  
R\_ETHER\_TIMEOUT(-2): Timeout  
R\_ETHER\_HARD\_ERROR(-3): Hardware error (Software reset required to recover.)  
R\_ETHER\_RECOVERABLE(-4): Recoverable error (Software reset not required to recover.)
- Properties  
Declared in **r\_ether.h** file  
Defined in **r\_ether.c** file
- Description  
The R\_Ether\_Write function writes transmit data to the buffer designated by the transmit descriptor. In addition to processing new data and waiting for transmission to complete, it updates the transmit descriptor status.

Note: Do not use this function because it is not supported by the RX62N Ethernet driver. Use the R\_Ether\_Write function to transmit data from the transmit buffer.

### 4.5 Processing Procedure of Sample Program

Figures 4.18 and 4.19 show the processing sequence of the sample program, which uses the Ethernet driver API, and figures 4.20 to 4.28 show the processing sequence of the Ethernet driver API and its subordinate functions.

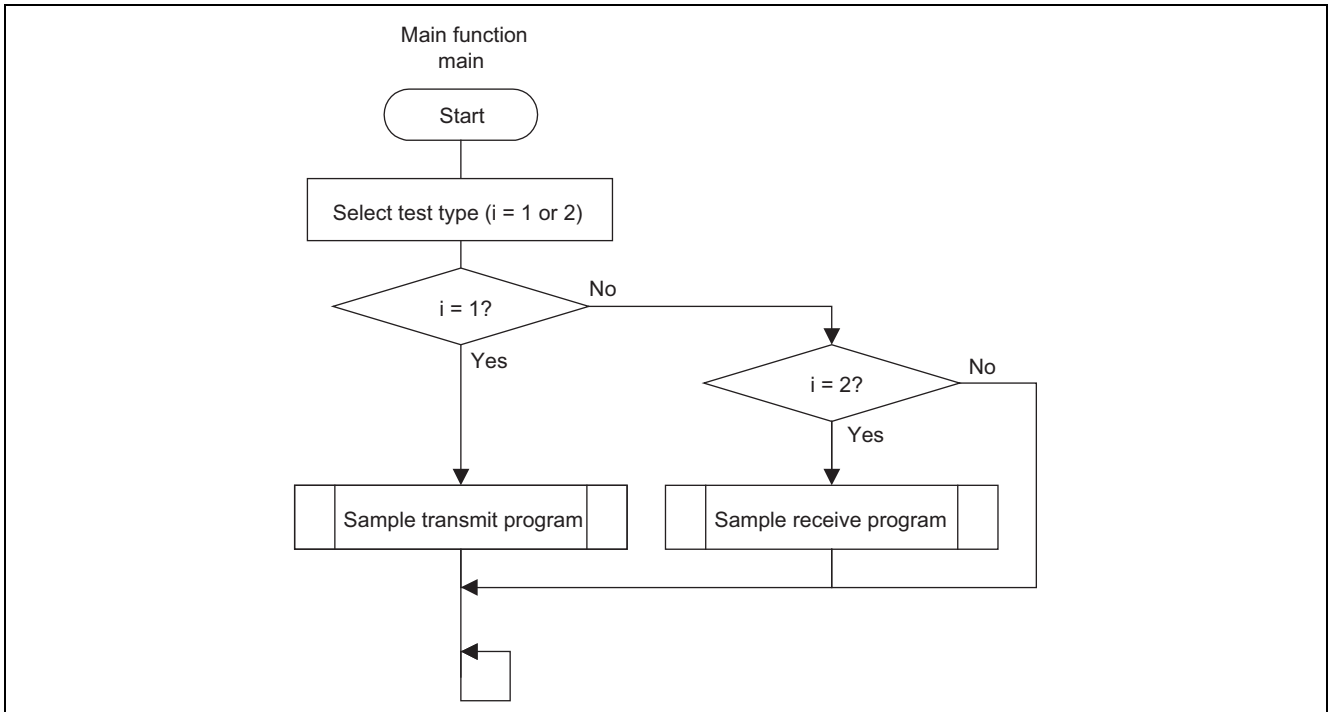

Figure 4.18 Main Processing Sequence of Sample Program (1)

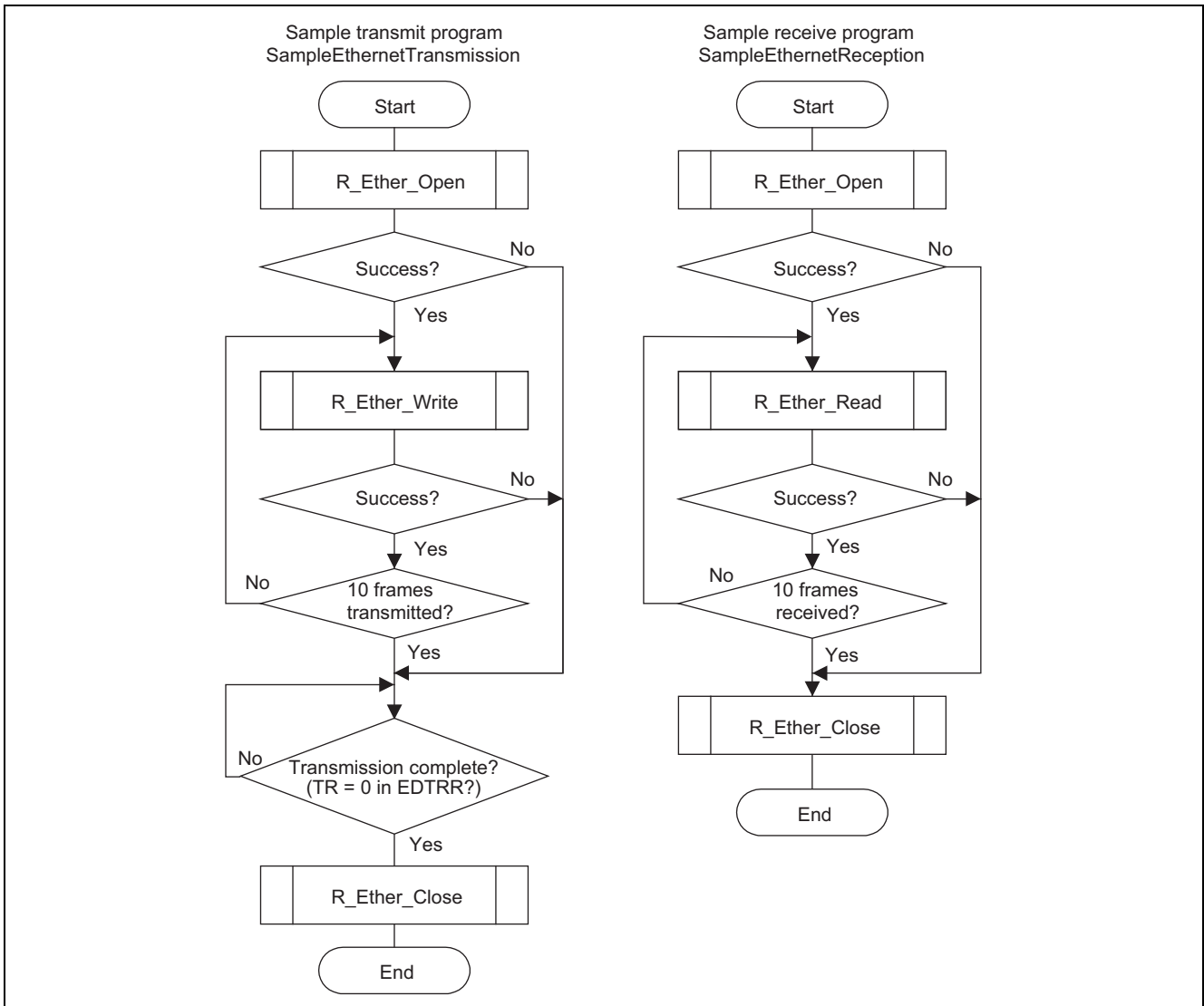

Figure 4.19 Main Processing Sequence of Sample Program (2)

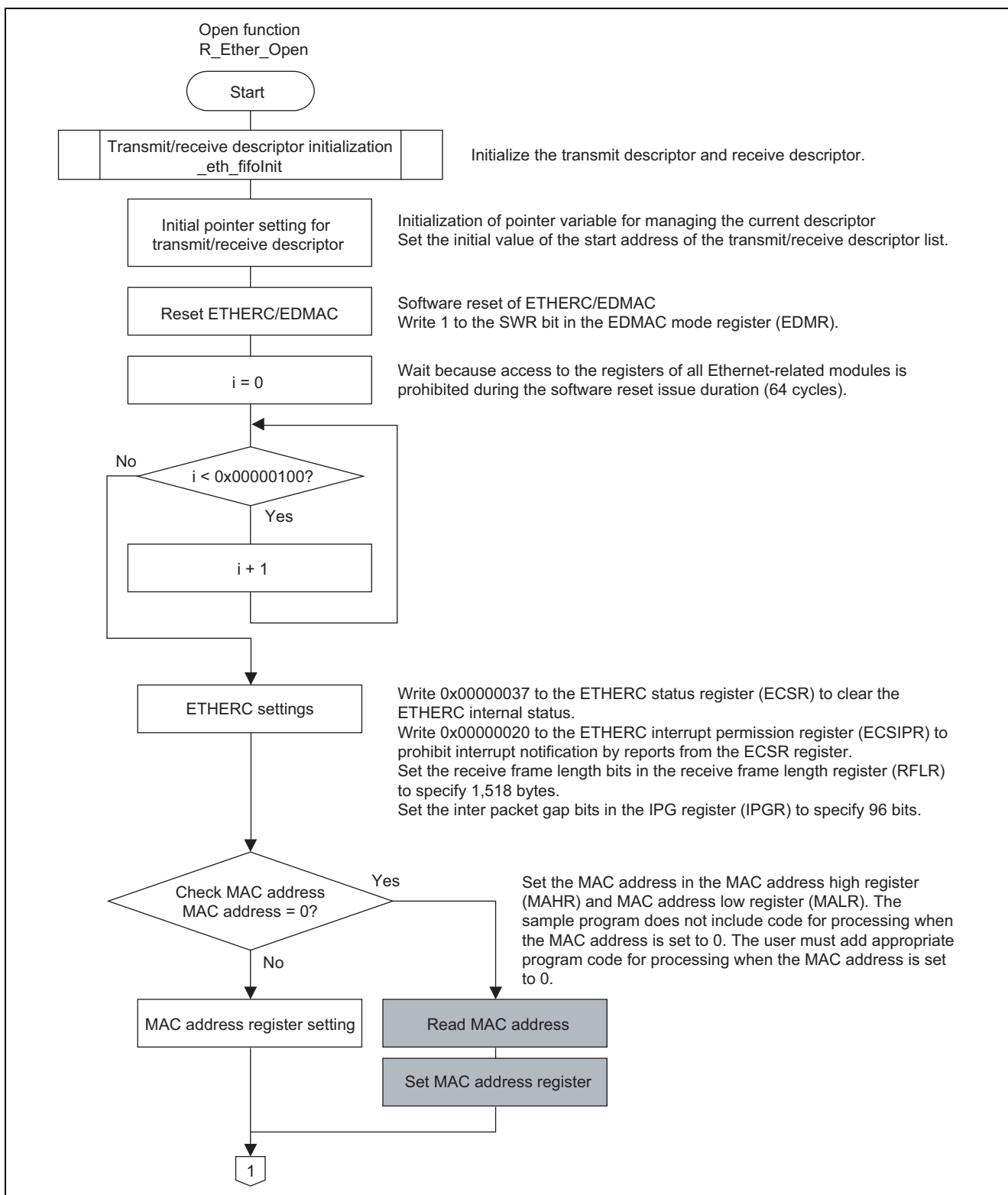

Figure 4.20 Ethernet API Processing Sequence of Sample Program (1)

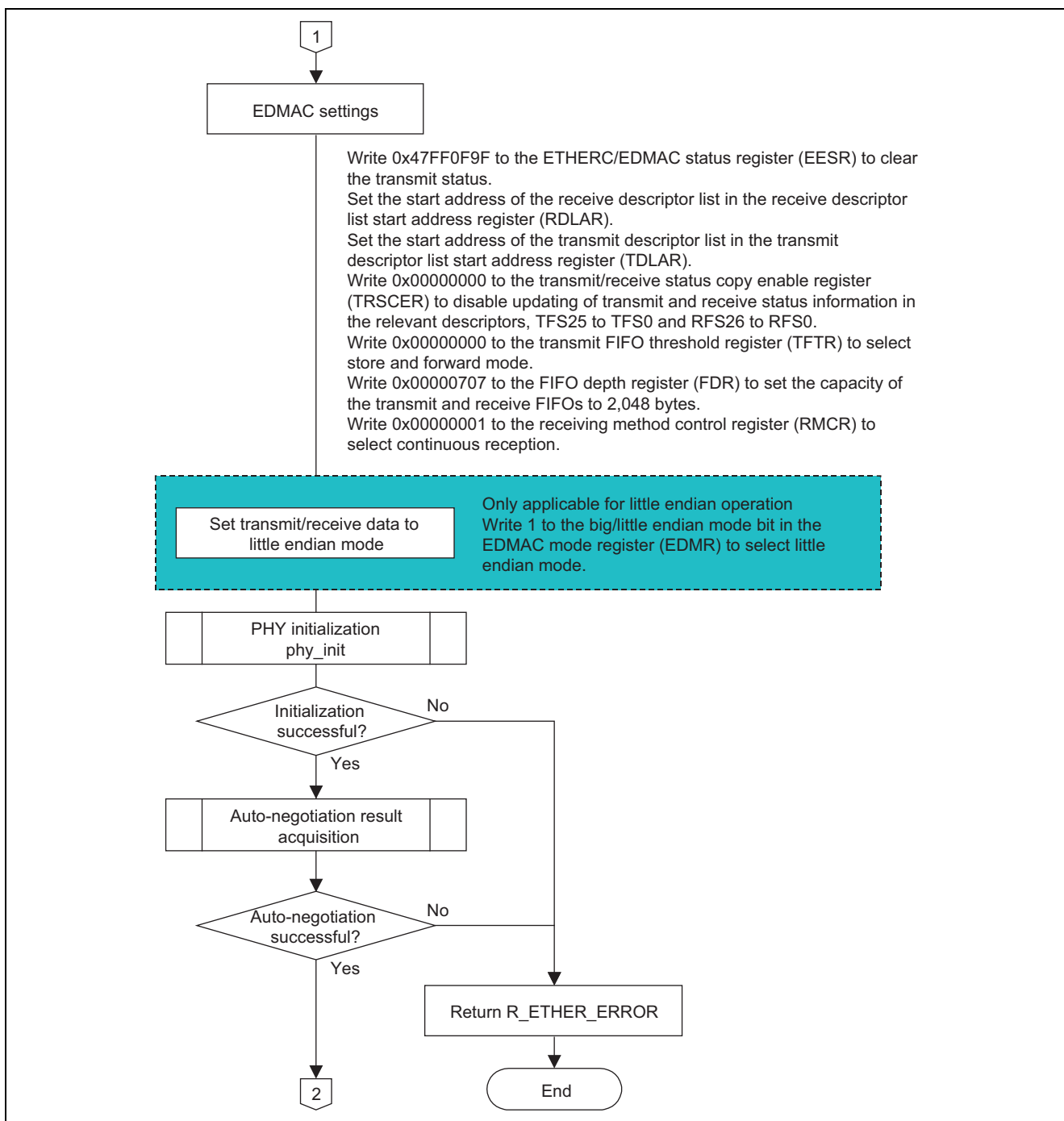

Figure 4.21 Ethernet API Processing Sequence of Sample Program (2)

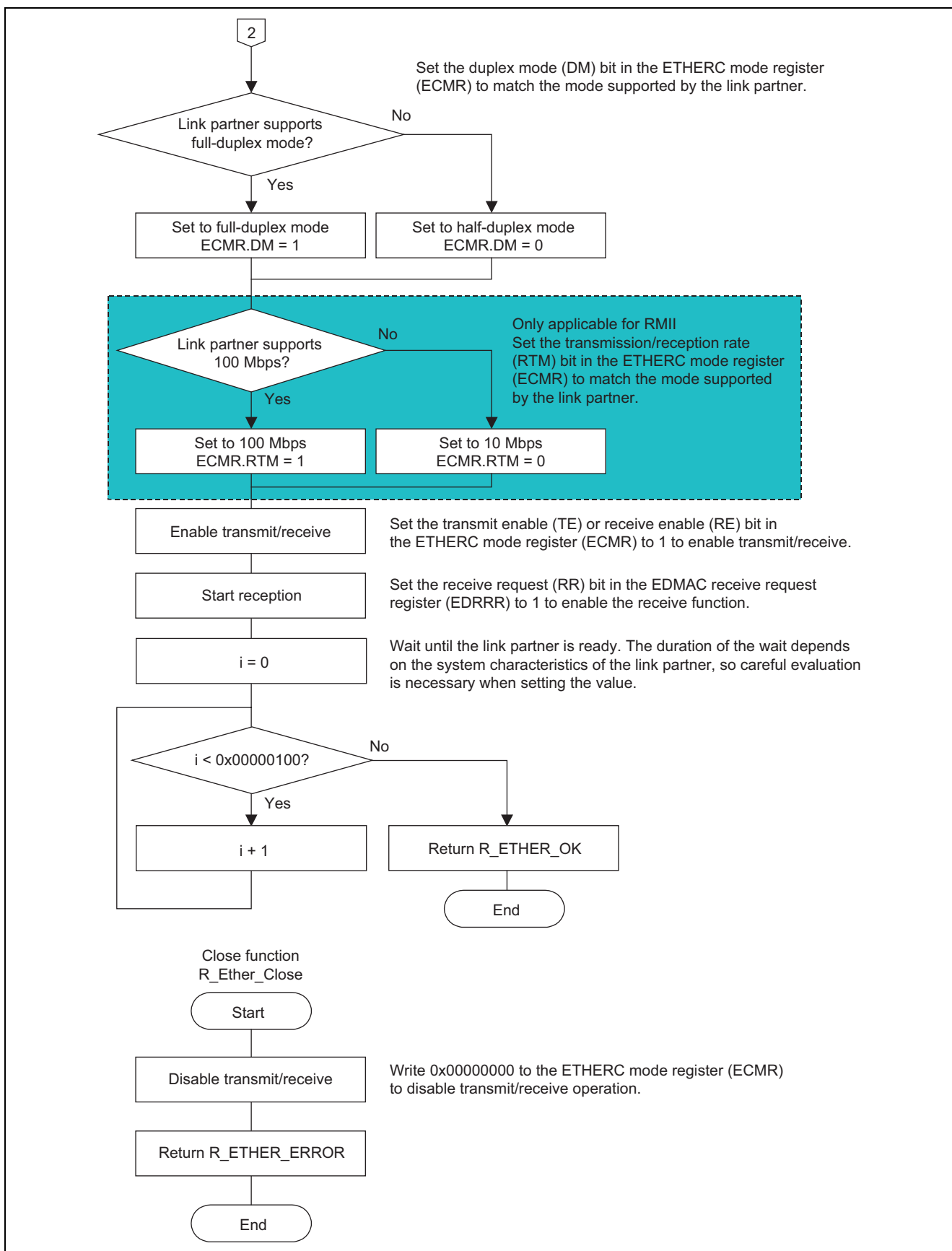

Figure 4.22 Ethernet API Processing Sequence of Sample Program (3)

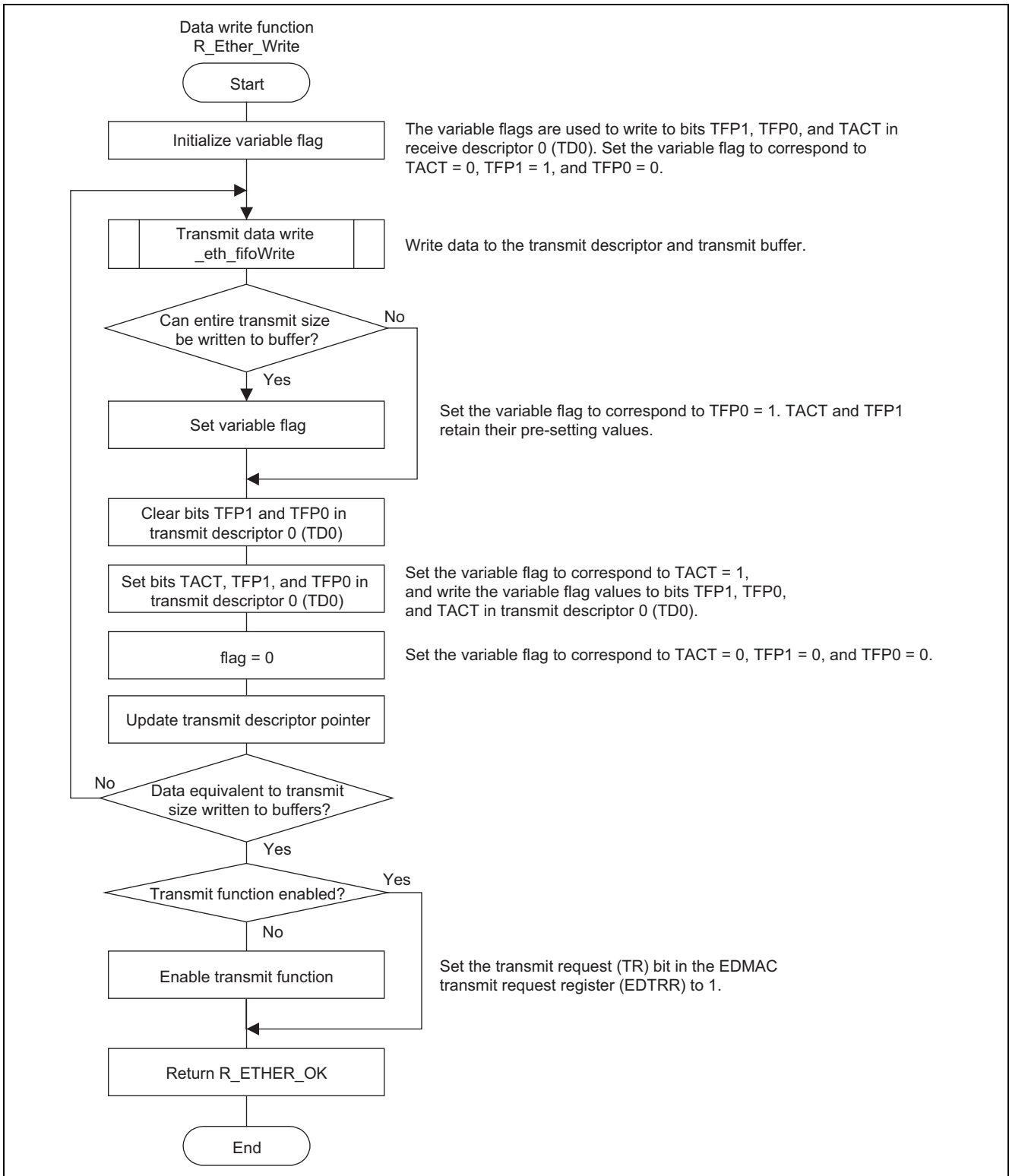

Figure 4.23 Ethernet API Processing Sequence of Sample Program (4)

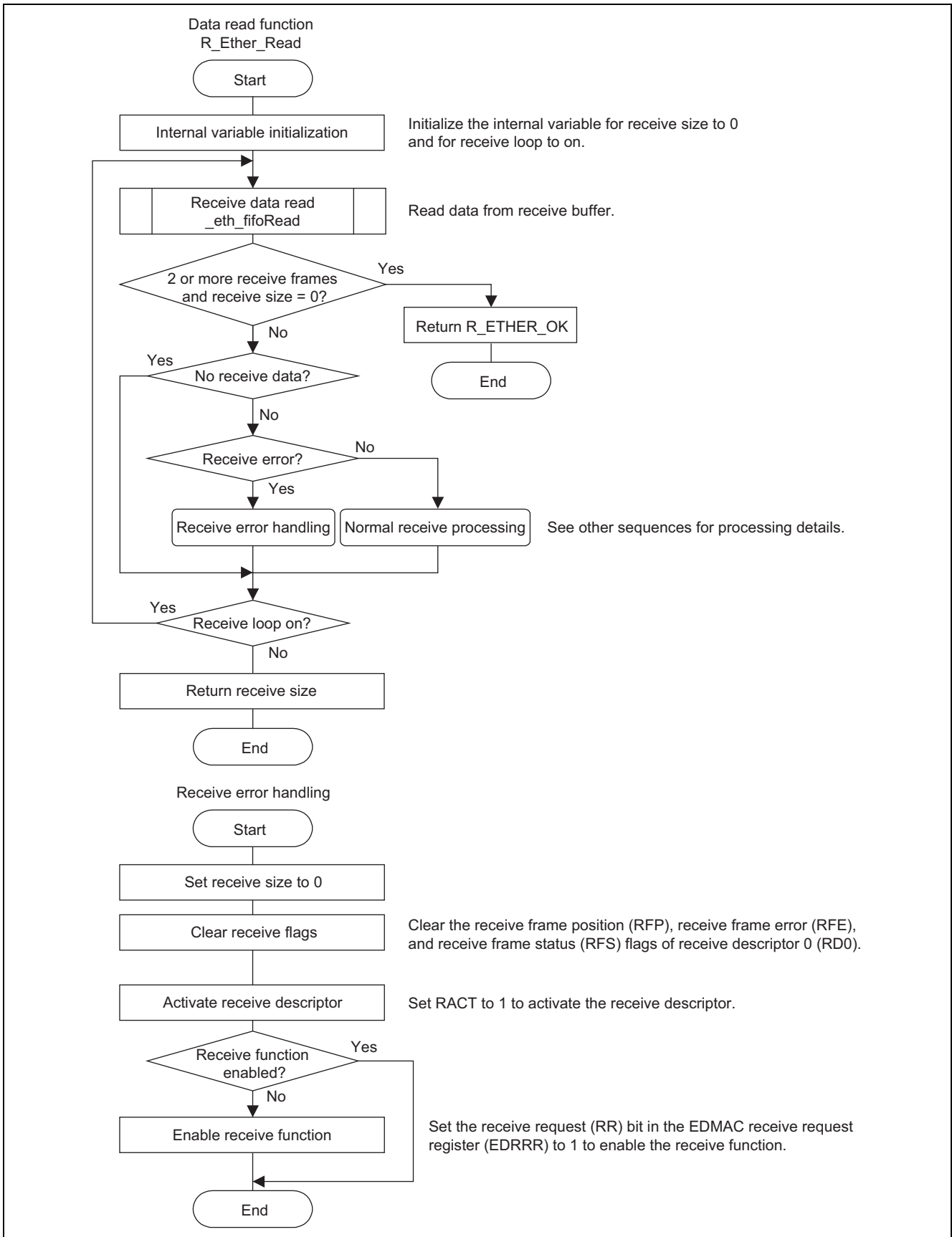

Figure 4.24 Ethernet API Processing Sequence of Sample Program (5)

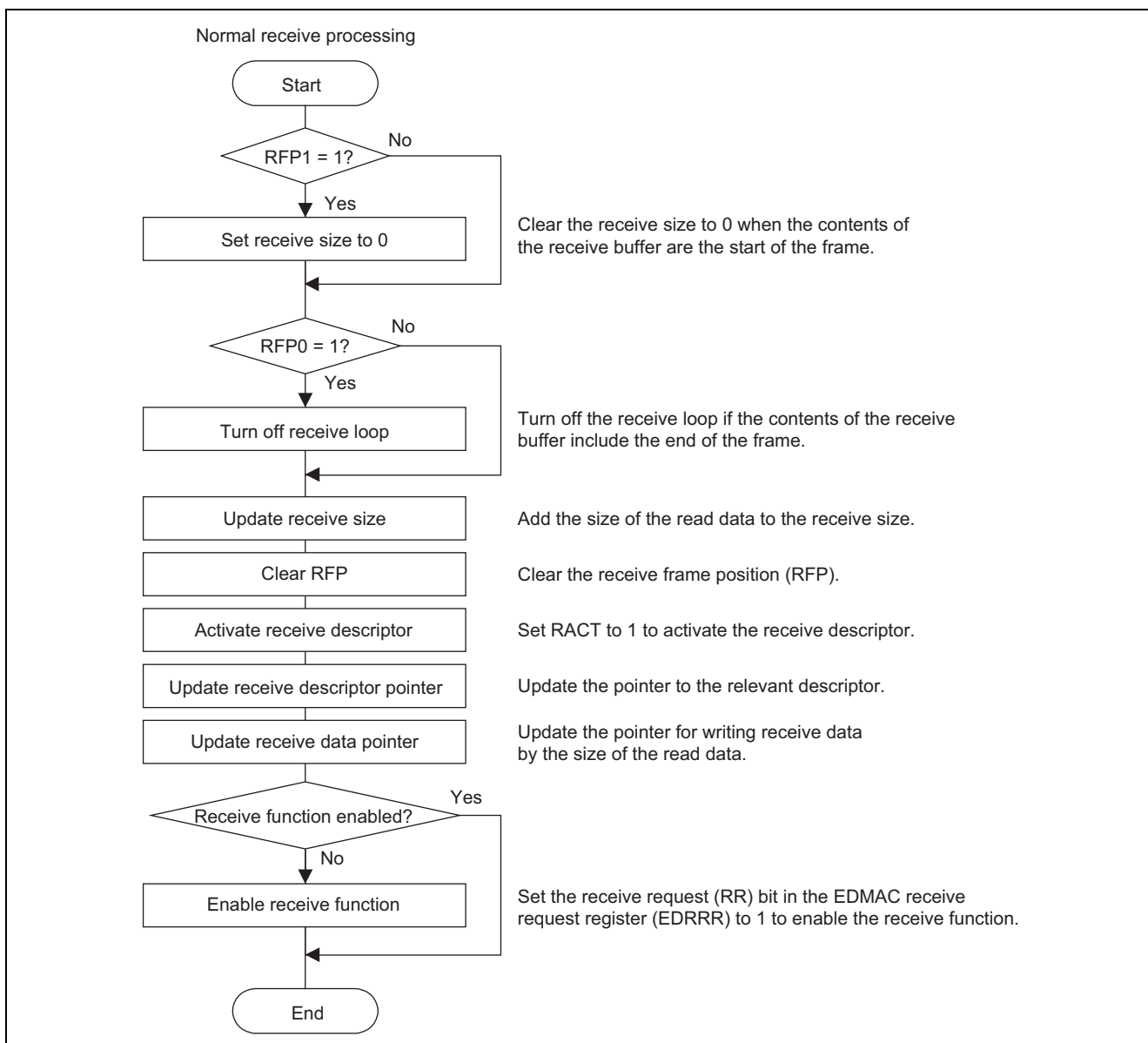

Figure 4.25 Ethernet API Processing Sequence of Sample Program (6)

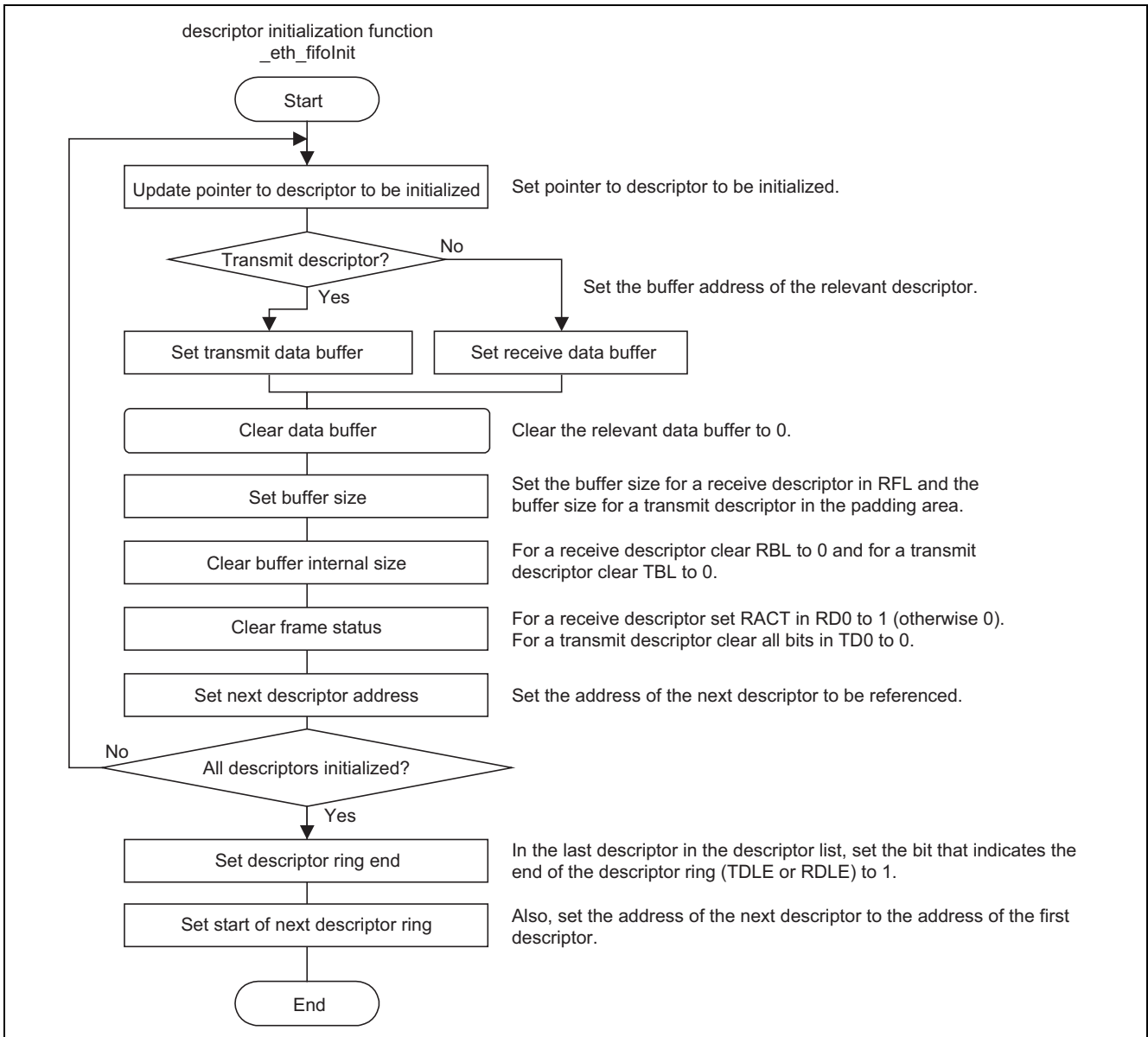

Figure 4.26 Sample Program Descriptor Processing Sequence (1)

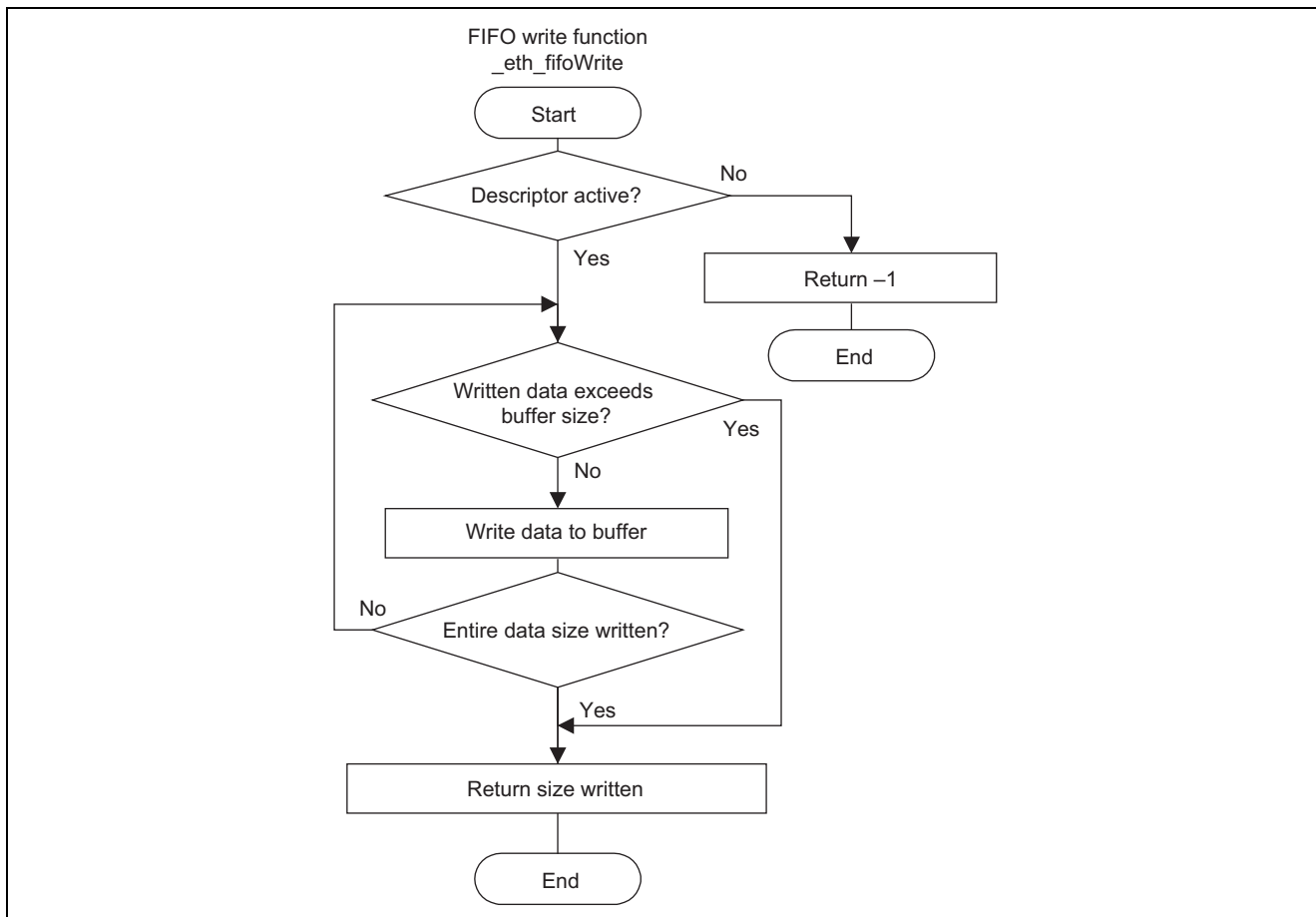

Figure 4.27 Sample Program Descriptor Processing Sequence (2)

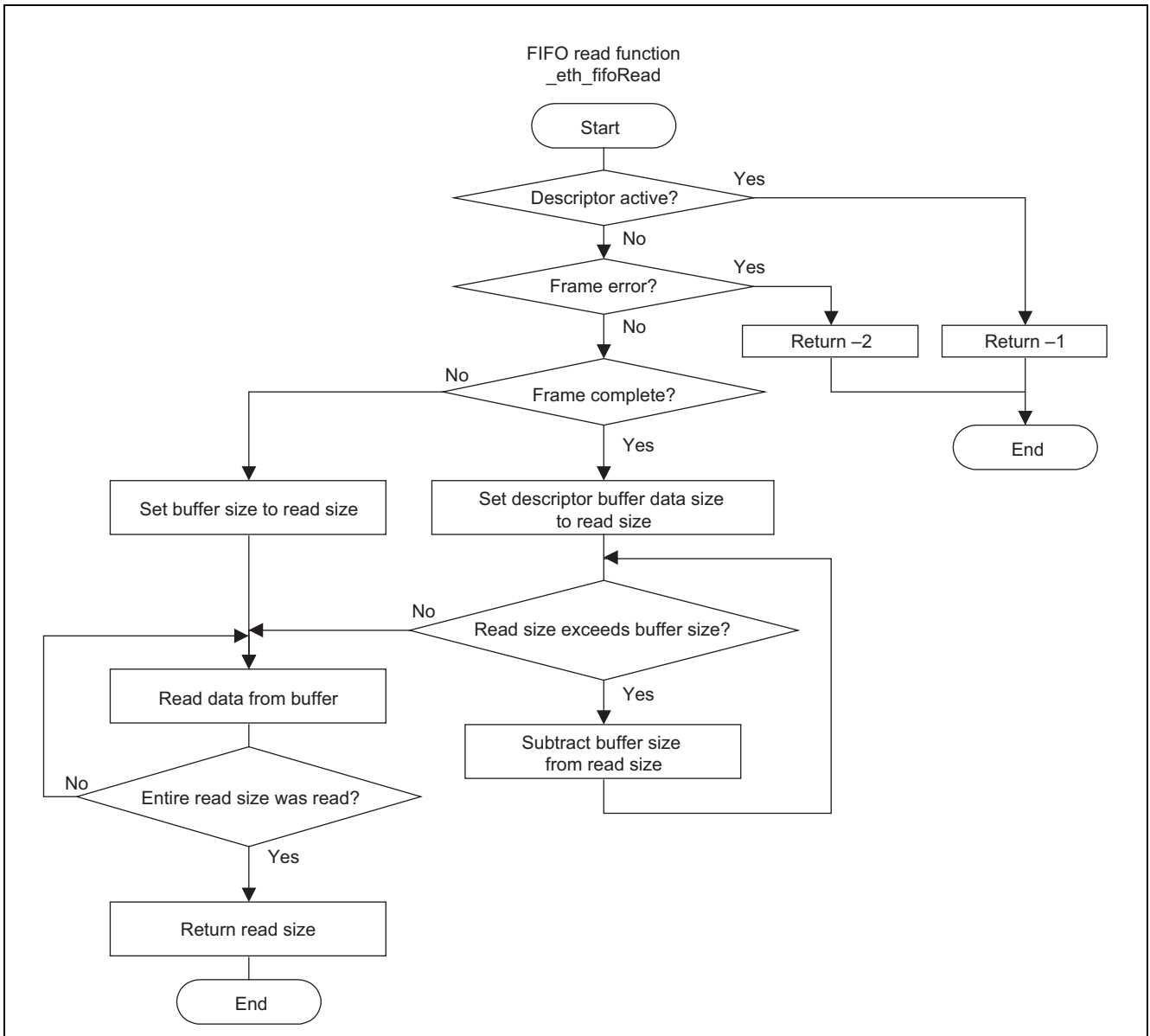

Figure 4.28 Sample Program Descriptor Processing Sequence (3)

## 4.6 Notes on Transmit/Receive Settings

### 4.6.1 Note on Operating Environment

The sample program uses the auto-negotiation function to select the communication mode. If the amount of time required for auto-negotiation by the RX62N and the connection partner of the RX62N (the hub in figure 4.14) differs considerably, communication may fail even though auto-negotiation is successful.

If the connection partner of the RX62N cannot receive even after auto-negotiation completes successfully, insert a wait period on the RX62N side to enable the connection partner to enter the ready-to-receive state. The amount of time needed for the connection partner to enter the ready-to-receive state will differ depending on the system, so the user should perform sufficient evaluation when determining the wait period.

To adjust the duration of the wait period, modify the following lines of code in the R\_EtherOpen function (lines 278 to 280) in the **r\_ether.c** file.

```
/* Delay to stabilize */  
/* Set the count according to the system */  
for( i = 0 ; i < 0x0000100 ; i++ );
```

### 4.6.2 Note on Interrupt Handling

The sample program does not use interrupt functions. In order to use interrupts, the user must add appropriate program code.

### 4.6.3 Note on Error Handling

The sample program does not include routines for handling transmit or receive errors. If error handling is required, the user must add appropriate program code.

### 4.6.4 Note on Transmit/Receive Buffer Size

The buffers must align with a 32-byte boundary, so the value defined by BUFSIZE in the **r\_ether.h** file assures a 32-byte aligned value in RAM.

### 4.6.5 Note on Reception Mode

When continuous reception is selected (receive request bit reset (RNR) bit in receiving method control register (RMCR) set to 1), the EDMAC reads the next descriptor and enters the receive standby state if the value of the RACT bit is 1.

In continuous reception mode, setting the receive request bit non-reset mode (RNC) bit in the RMCR register to 1 causes EDMAC receive operation to continue, with no clearing of the RR bit even if the RACT bit is cleared to 0 (inactive). (Receive descriptors are fetched consecutively, and receive frame DMA continues.)

This means that data may be overwritten before the receive data is passed to a higher layer. The setting that causes DMA to continue even when the RACT bit is cleared to 0 (inactive) should not be used under conditions requiring handshaking, such as TCP communication. This setting is recommended for use in conditions such as UDP communication where real-time performance is essential and retransmission is not required.

## 5. Endian Mode Selection in Sample Program

In the compile options of the RX compiler, big endian is defined as the predefined macro `__BIG` and little endian as `__LIT`. The sample program uses these macros to absorb the difference due to the endian mode selection.

### 5.1 Big Endian Mode

For big-endian operation, make the following settings, and set the Pin3 of SW4 on the Renesas Starter Kit +(product number: R0K5562N0C000BE) to OFF (MDE=Hi).

- 1. Launch RX Standard Toolchain by selecting **Build** → **RX Standard Toolchain** from the HEW toolbar.
- 2. On the **CPU** tab select **Big** under **Endian**, then click **OK**.
- 3. Build the file once again.

### 5.2 Little Endian Mode

For little-endian operation, make the following settings, and set the Pin3 of SW4 on the Renesas Starter Kit +(product number: R0K5562N0C000BE) to ON (MDE=Low).

- 1. Launch RX Standard Toolchain by selecting **Build** → **RX Standard Toolchain** from the HEW toolbar.
- 2. On the **CPU** tab select **Little** under **Endian**, then click **OK**.
- 3. Build the file once again.

## 6. Interface (MII/RMII) Selection in Sample Program

MII/RMII selection can be accomplished by switching macros. Make the appropriate change to `ETH_MODE_SEL`, which is defined in `r_ether.h`.

### 6.1 MII

As shown below, set `ETH_MODE_SEL` to `ETH_MII_MODE` in the `r_ether.h` file.

```
#define ETH_MODE_SEL ETH_MII_MODE
```

### 6.2 RMII

As shown below, set `ETH_MODE_SEL` to `ETH_RMII_MODE` in the `r_ether.h` file. Please note that the Renesas Starter Kit +(product number: R0K5562N0C000BE) supports the MII (Media Independent Interface) only, and doesn't support RMII (Reduced Media Independent Interface).

```
#define ETH_MODE_SEL ETH_RMII_MODE
```

## 7. Allocation of Sections in Sample Program

Table 7.1 shows the allocation of sections by the sample program.

For details on the compiler, see section 5, Optimizing Linkage Editor Options, and 8.1, Program Structure, in *RX Family C/C++ Compiler, Assembler, Optimizing Linkage Editor: Compiler Package User's Manual*.

Table 7.1 Allocation of Sections in Sample Program

Address	Device	Section	Description	
0x00001000	On-chip RAM	B_RX_DESC	Receive descriptor area	
		B_TX_DESC	Transmit descriptor area	
		B_RX_BUFF_1	Receive buffer area	
		B_TX_BUFF_1	Transmit buffer area	
		B_1	Uninitialized data area with 1-byte alignment	
		R_1	Initialized data area (variable) with 1-byte alignment	
		B_2	Uninitialized data area with 2-byte alignment	
		R_2	Initialized data area (variable) with 2-byte alignment	
		B	Uninitialized data area with 4-byte alignment	
		R	Initialized data area (variable) with 4-byte alignment	
		SU	User stack area	
		SI	Interrupt stack area	
				BETH_BUFF
0xFFFF80000	On-chip ROM	PRResetPRG	Program area of ResetPRG section (initial settings program)	
0xFFFF80100		C_1	Constant area with 1-byte alignment	
		C_2	Constant area with 2-byte alignment	
		C	Constant area with 4-byte alignment	
		C\$*	Constant area of C\$* sections (C\$DSEC, C\$BSEC, C\$VECT)	
		D*	Initialized data area (initial value)	
		P	Program area with no section definition	
		PIntPRG	Program area of IntPRG section (interrupt)	
		W*	Switch statement branch table area	
		0xFFFFFFF00	FIXEDVECT	FIXEDVECT section area

### 7.1 Notes on Allocation of Sections

- The sample program set the transmit/receive descriptor length (DL) bits in the EDMAC mode register (EDMR) to specify 16 bytes, so the B\_RX\_DESC and B\_TX\_DESC sections should be allocated so that they are aligned with 16-byte boundaries.
- Allocate the B\_RX\_BUFF\_1 and B\_TX\_BUFF\_1 sections so that they are aligned with 32-byte boundaries.

## 8. Note on Use of Renesas Starter Kit +

Please note that the Renesas Starter Kit +(product number: R0K5562N0C000BE) supports the MII (Media Independent Interface) only, and doesn't support RMII (Reduced Media Independent Interface). Must select MII from the interface of the reference program (MII/RMII) according to 6.1.

## 9. Reference Documents

- RX62N Group Hardware Manual  
(The latest version can be downloaded from the Renesas Electronics Web site.)
- RX Family Software Manual  
(The latest version can be downloaded from the Renesas Electronics Web site.)
- RX Family Compiler Package User's Manual  
(The latest version can be downloaded from the Renesas Electronics Web site.)
- Standard Microsystems Corporation LAN8700/LAN8700i Datasheet  
(The latest version can be downloaded from the Standard Microsystems Corporation Web site.)

### Website and Support

- Renesas Electronics Website  
<http://www.renesas.com/>
- Inquiries  
<http://www.renesas.com/inquiry>

All trademarks and registered trademarks are the property of their respective owners.

## Revision Record

Rev.	Date	Description	
		Page	Summary
1.00	Dec.27.10	—	First edition issued
1.01	Mar.31.11	1,3,16,17, 31,49,50	Change target board to the Renesas Starter Kit +(product number: R0K5562N0C000BE).

## General Precautions in the Handling of MPU/MCU Products

The following usage notes are applicable to all MPU/MCU products from Renesas. For detailed usage notes on the products covered by this manual, refer to the relevant sections of the manual. If the descriptions under General Precautions in the Handling of MPU/MCU Products and in the body of the manual differ from each other, the description in the body of the manual takes precedence.

### 1. Handling of Unused Pins

Handle unused pins in accord with the directions given under Handling of Unused Pins in the manual.

- The input pins of CMOS products are generally in the high-impedance state. In operation with an unused pin in the open-circuit state, extra electromagnetic noise is induced in the vicinity of LSI, an associated shoot-through current flows internally, and malfunctions occur due to the false recognition of the pin state as an input signal become possible. Unused pins should be handled as described under Handling of Unused Pins in the manual.

### 2. Processing at Power-on

The state of the product is undefined at the moment when power is supplied.

- The states of internal circuits in the LSI are indeterminate and the states of register settings and pins are undefined at the moment when power is supplied.

In a finished product where the reset signal is applied to the external reset pin, the states of pins are not guaranteed from the moment when power is supplied until the reset process is completed.

In a similar way, the states of pins in a product that is reset by an on-chip power-on reset function are not guaranteed from the moment when power is supplied until the power reaches the level at which resetting has been specified.

### 3. Prohibition of Access to Reserved Addresses

Access to reserved addresses is prohibited.

- The reserved addresses are provided for the possible future expansion of functions. Do not access these addresses; the correct operation of LSI is not guaranteed if they are accessed.

### 4. Clock Signals

After applying a reset, only release the reset line after the operating clock signal has become stable. When switching the clock signal during program execution, wait until the target clock signal has stabilized.

- When the clock signal is generated with an external resonator (or from an external oscillator) during a reset, ensure that the reset line is only released after full stabilization of the clock signal. Moreover, when switching to a clock signal produced with an external resonator (or by an external oscillator) while program execution is in progress, wait until the target clock signal is stable.

### 5. Differences between Products

Before changing from one product to another, i.e. to one with a different part number, confirm that the change will not lead to problems.

- The characteristics of MPU/MCU in the same group but having different part numbers may differ because of the differences in internal memory capacity and layout pattern. When changing to products of different part numbers, implement a system-evaluation test for each of the products.

## Notice

- All information included in this document is current as of the date this document is issued. Such information, however, is subject to change without any prior notice. Before purchasing or using any Renesas Electronics products listed herein, please confirm the latest product information with a Renesas Electronics sales office. Also, please pay regular and careful attention to additional and different information to be disclosed by Renesas Electronics such as that disclosed through our website.
- Renesas Electronics does not assume any liability for infringement of patents, copyrights, or other intellectual property rights of third parties by or arising from the use of Renesas Electronics products or technical information described in this document. No license, express, implied or otherwise, is granted hereby under any patents, copyrights or other intellectual property rights of Renesas Electronics or others.
- You should not alter, modify, copy, or otherwise misappropriate any Renesas Electronics product, whether in whole or in part.
- Descriptions of circuits, software and other related information in this document are provided only to illustrate the operation of semiconductor products and application examples. You are fully responsible for the incorporation of these circuits, software, and information in the design of your equipment. Renesas Electronics assumes no responsibility for any losses incurred by you or third parties arising from the use of these circuits, software, or information.
- When exporting the products or technology described in this document, you should comply with the applicable export control laws and regulations and follow the procedures required by such laws and regulations. You should not use Renesas Electronics products or the technology described in this document for any purpose relating to military applications or use by the military, including but not limited to the development of weapons of mass destruction. Renesas Electronics products and technology may not be used for or incorporated into any products or systems whose manufacture, use, or sale is prohibited under any applicable domestic or foreign laws or regulations.
- Renesas Electronics has used reasonable care in preparing the information included in this document, but Renesas Electronics does not warrant that such information is error free. Renesas Electronics assumes no liability whatsoever for any damages incurred by you resulting from errors in or omissions from the information included herein.
- Renesas Electronics products are classified according to the following three quality grades: "Standard", "High Quality", and "Specific". The recommended applications for each Renesas Electronics product depends on the product's quality grade, as indicated below. You must check the quality grade of each Renesas Electronics product before using it in a particular application. You may not use any Renesas Electronics product for any application categorized as "Specific" without the prior written consent of Renesas Electronics. Further, you may not use any Renesas Electronics product for any application for which it is not intended without the prior written consent of Renesas Electronics. Renesas Electronics shall not be in any way liable for any damages or losses incurred by you or third parties arising from the use of any Renesas Electronics product for an application categorized as "Specific" or for which the product is not intended where you have failed to obtain the prior written consent of Renesas Electronics. The quality grade of each Renesas Electronics product is "Standard" unless otherwise expressly specified in a Renesas Electronics data sheets or data books, etc.  
"Standard": Computers; office equipment; communications equipment; test and measurement equipment; audio and visual equipment; home electronic appliances; machine tools; personal electronic equipment; and industrial robots.  
"High Quality": Transportation equipment (automobiles, trains, ships, etc.); traffic control systems; anti-disaster systems; anti-crime systems; safety equipment; and medical equipment not specifically designed for life support.  
"Specific": Aircraft; aerospace equipment; submersible repeaters; nuclear reactor control systems; medical equipment or systems for life support (e.g. artificial life support devices or systems), surgical implantations, or healthcare intervention (e.g. excision, etc.), and any other applications or purposes that pose a direct threat to human life.
- You should use the Renesas Electronics products described in this document within the range specified by Renesas Electronics, especially with respect to the maximum rating, operating supply voltage range, movement power voltage range, heat radiation characteristics, installation and other product characteristics. Renesas Electronics shall have no liability for malfunctions or damages arising out of the use of Renesas Electronics products beyond such specified ranges.
- Although Renesas Electronics endeavors to improve the quality and reliability of its products, semiconductor products have specific characteristics such as the occurrence of failure at a certain rate and malfunctions under certain use conditions. Further, Renesas Electronics products are not subject to radiation resistance design. Please be sure to implement safety measures to guard them against the possibility of physical injury, and injury or damage caused by fire in the event of the failure of a Renesas Electronics product, such as safety design for hardware and software including but not limited to redundancy, fire control and malfunction prevention, appropriate treatment for aging degradation or any other appropriate measures. Because the evaluation of microcomputer software alone is very difficult, please evaluate the safety of the final products or system manufactured by you.
- Please contact a Renesas Electronics sales office for details as to environmental matters such as the environmental compatibility of each Renesas Electronics product. Please use Renesas Electronics products in compliance with all applicable laws and regulations that regulate the inclusion or use of controlled substances, including without limitation, the EU RoHS Directive. Renesas Electronics assumes no liability for damages or losses occurring as a result of your noncompliance with applicable laws and regulations.
- This document may not be reproduced or duplicated, in any form, in whole or in part, without prior written consent of Renesas Electronics.
- Please contact a Renesas Electronics sales office if you have any questions regarding the information contained in this document or Renesas Electronics products, or if you have any other inquiries.  
(Note 1) "Renesas Electronics" as used in this document means Renesas Electronics Corporation and also includes its majority-owned subsidiaries.  
(Note 2) "Renesas Electronics product(s)" means any product developed or manufactured by or for Renesas Electronics.



### SALES OFFICES

Renesas Electronics Corporation

<http://www.renesas.com>

Refer to "<http://www.renesas.com/>" for the latest and detailed information.

**Renesas Electronics America Inc.**  
2880 Scott Boulevard Santa Clara, CA 95050-2554, U.S.A.  
Tel: +1-408-586-6000, Fax: +1-408-586-6130

**Renesas Electronics Canada Limited**  
1101 Nicholson Road, Newmarket, Ontario L3Y 9C3, Canada  
Tel: +1-905-898-5441, Fax: +1-905-898-3220

**Renesas Electronics Europe Limited**  
Dukes Meadow, Millboard Road, Bourne End, Buckinghamshire, SL8 5FH, U.K.  
Tel: +44-1628-585-100, Fax: +44-1628-585-900

**Renesas Electronics Europe GmbH**  
Arcadiastrasse 10, 40472 Düsseldorf, Germany  
Tel: +49-211-65030, Fax: +49-211-6503-1327

**Renesas Electronics (China) Co., Ltd.**  
7th Floor, Quantum Plaza, No.27 ZhiChunLu Haidian District, Beijing 100083, P.R.China  
Tel: +86-10-8235-1155, Fax: +86-10-8235-7679

**Renesas Electronics (Shanghai) Co., Ltd.**  
Unit 204, 205, AZIA Center, No.1233 Lujiazui Ring Rd., Pudong District, Shanghai 200120, China  
Tel: +86-21-5877-1818, Fax: +86-21-6887-7858 / -7898

**Renesas Electronics Hong Kong Limited**  
Unit 1601-1613, 16/F., Tower 2, Grand Century Place, 193 Prince Edward Road West, Mongkok, Kowloon, Hong Kong  
Tel: +852-2886-9318, Fax: +852 2886-9022/9044

**Renesas Electronics Taiwan Co., Ltd.**  
13F, No. 363, Fu Shing North Road, Taipei, Taiwan  
Tel: +886-2-8175-9600, Fax: +886 2-8175-9670

**Renesas Electronics Singapore Pte. Ltd.**  
1 HarbourFront Avenue, #06-10, Keppel Bay Tower, Singapore 098632  
Tel: +65-6213-0200, Fax: +65-6276-8001

**Renesas Electronics Malaysia Sdn.Bhd.**  
Unit 906, Block B, Menara Amcorp, Amcorp Trade Centre, No. 18, Jln Persiaran Barat, 46050 Petaling Jaya, Selangor Darul Ehsan, Malaysia  
Tel: +60-3-7955-9390, Fax: +60-3-7955-9510

**Renesas Electronics Korea Co., Ltd.**  
11F., Samik Lavied' or Bldg., 720-2 Yeoksam-Dong, Kangnam-Ku, Seoul 135-080, Korea  
Tel: +82-2-558-3737, Fax: +82-2-558-5141