

REV	REF	DATE	DRAWN BY
0.08	Draft	16.02.2011	TES
1.00	Release	15.04.2011	YOI
1.01	Release	30.06.2011	YOI

Renesas Starter Kit for RL78/G13 CPU Board Schematics

PAGE	DESCRIPTION
1	INDEX
2	RL78/G13 Microcontroller
3	Switches, LEDs, RESET, PSU
4	E1, Serial Port
5	Application Headers, Pin Function Select, Debug LCD
6	Microcontroller Pin Headers
7	LIN

Note:

R : Fixed Resistor
RV : Potentiometer
U : Integrated Circuit
X : Crystal
RES : Reset Switch
SW : Switch
LED : Light Emitting Diode
PWR : Power Jack
J : Connetor, Jumper

* "DNF" marking means that component does not fit by default.

Board Code:

R0K50100LC000BE : Release version Board

REEL Drwaing No. D010232_04

Renesas Solutions Corp.		
Title RSKRL78G13 [INDEX]		
Size A4	Document Number R20UT0458EG0101	Rev 1.01
Date:	Thursday, June 30, 2011	Sheet 1 of 7

RL78/G13 Microcontroller

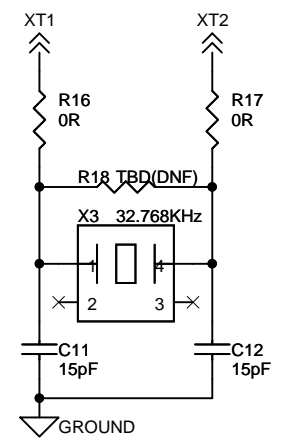
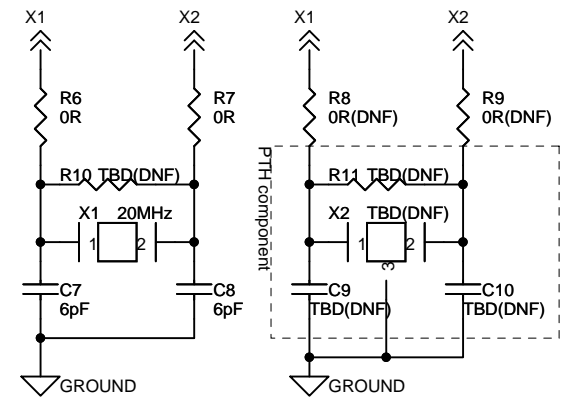
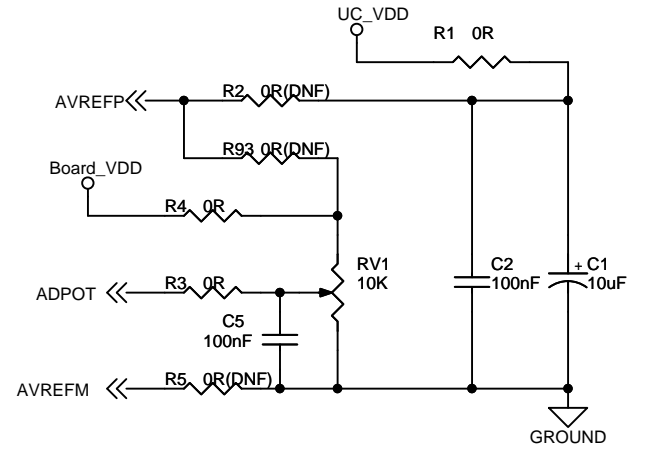
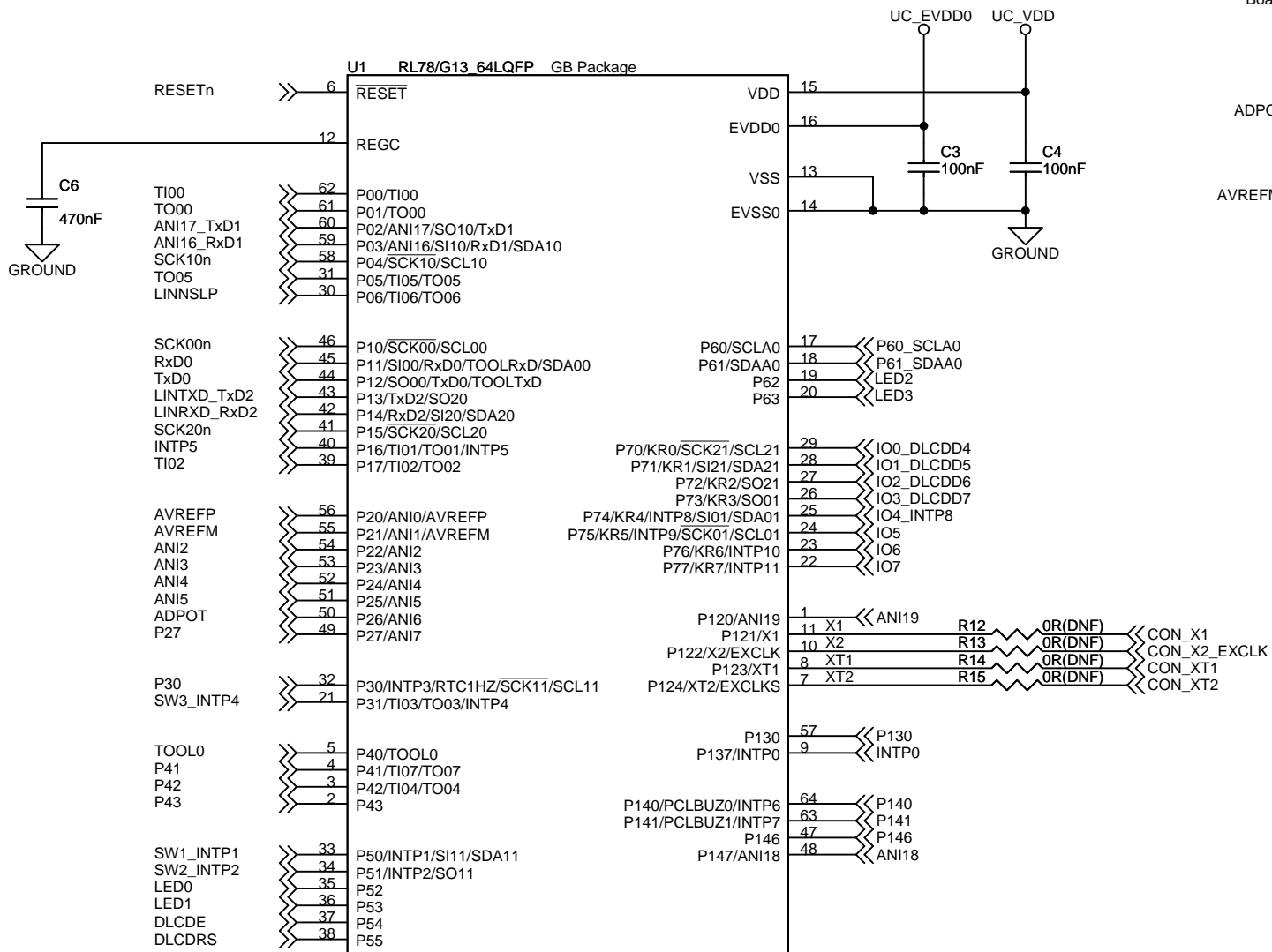

Renesas Solutions Corp.			
Title RSKRL78G13 [Micon]			
Size A4	Document Number R20UT0458EG0101	Rev 1.01	
Date: Thursday, June 30, 2011	Sheet 2	of 7	

PSU

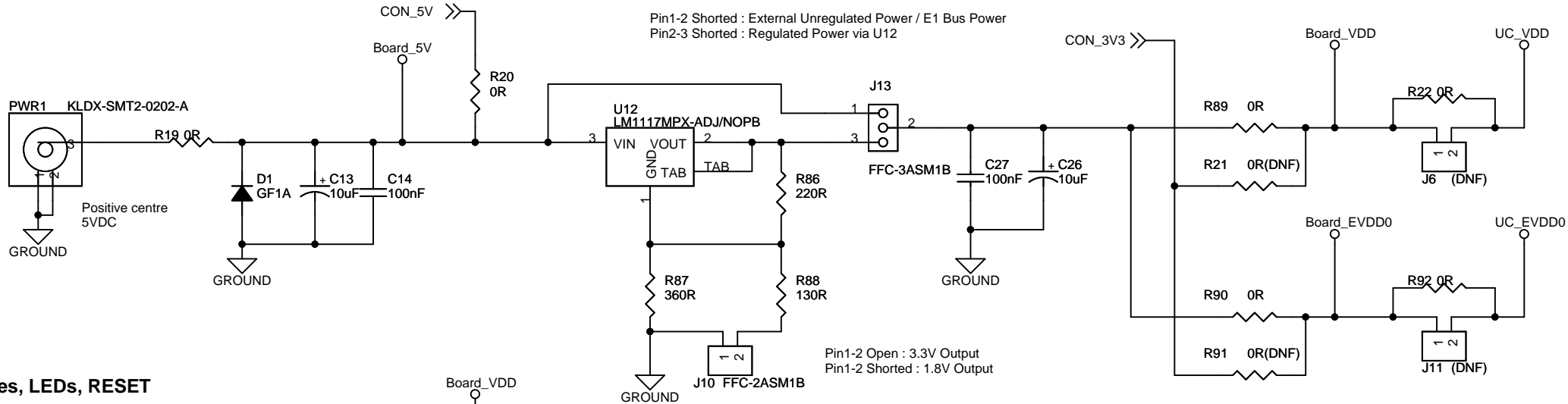

Switches, LEDs, RESET

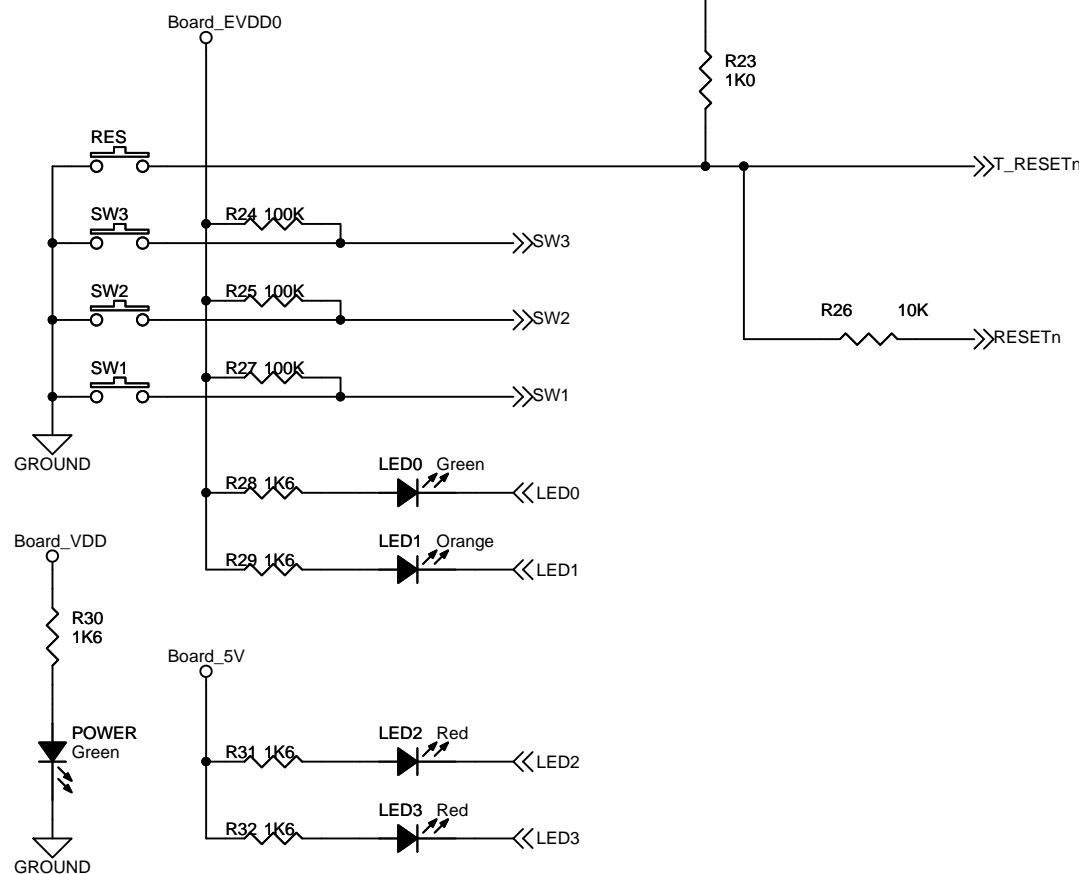

Ground Test Points

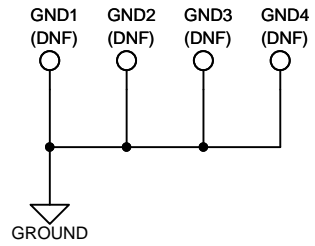

Renesas Solutions Corp.		
Title RSKRL78G13 [Switches, LEDs, RESET, PSU]		
Size A4	Document Number R20UT0458EG0101	Rev 1.01
Date Thursday, June 30, 2011	Sheet 3	of 7

Serial Port

The board is designed to accept a straight-through RS232 male-to-female cable.

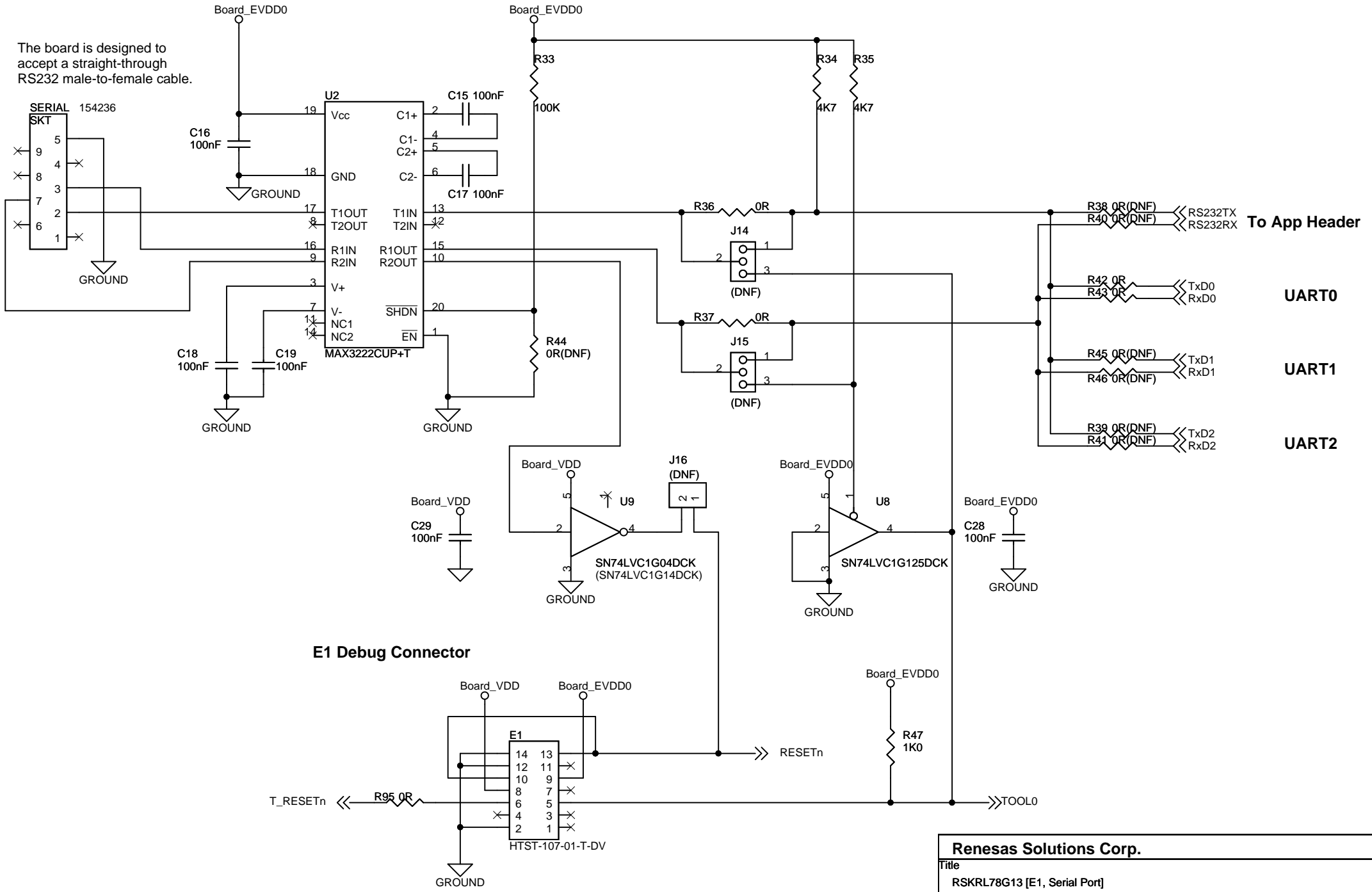

E1 Debug Connector

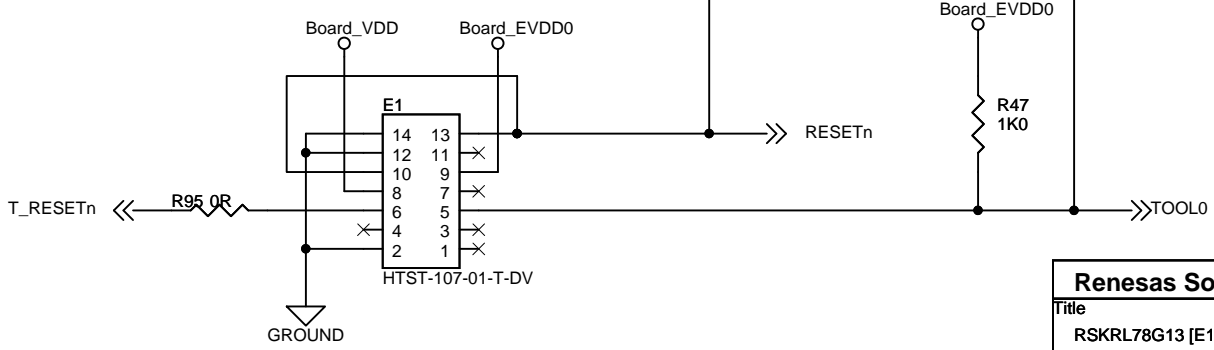

Renesas Solutions Corp.		
Title RSKRL78G13 [E1, Serial Port]		
Size A4	Document Number R20UT0458EG0101	Rev 1.01
Date: Thursday, June 30, 2011	Sheet 4	of 7

Application Board Interface

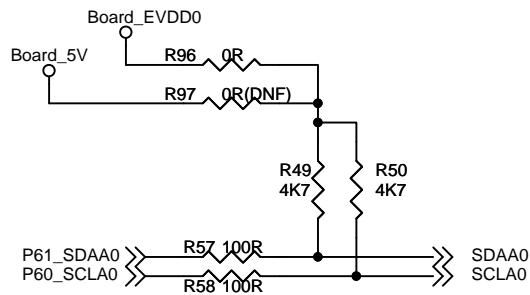
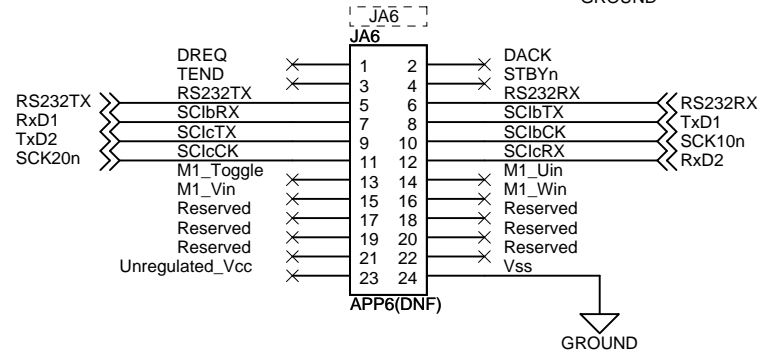
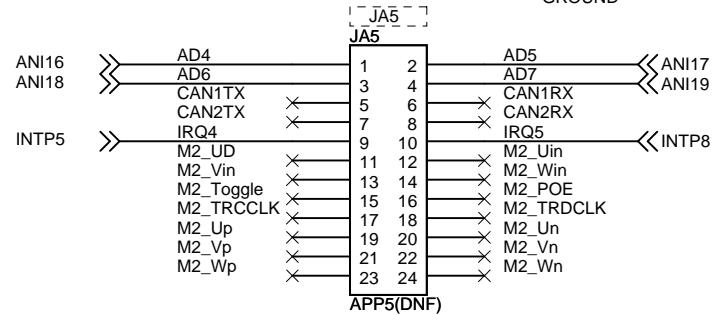
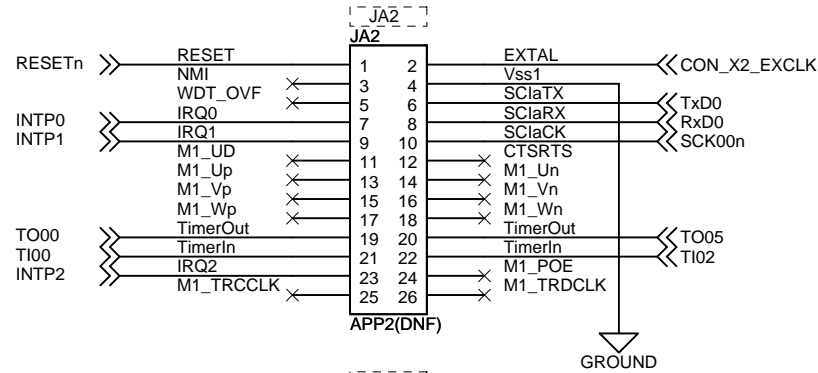
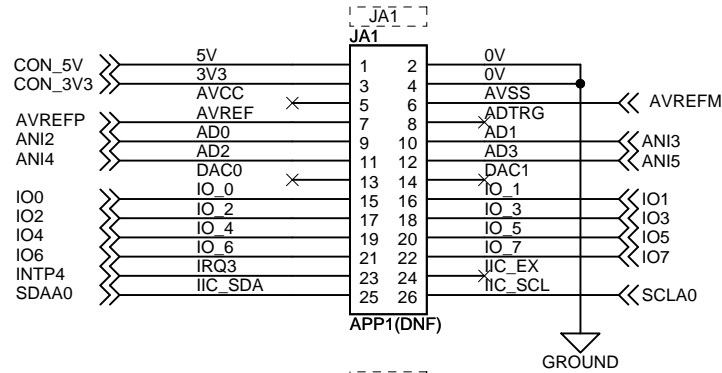

Microcontroller Pin Function Select

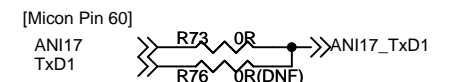
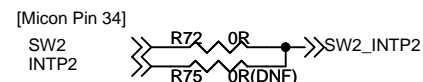
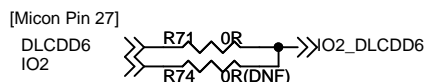
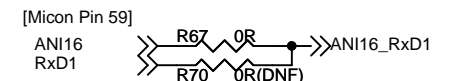
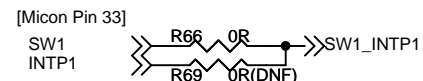
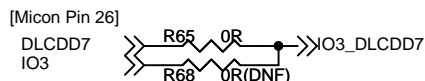
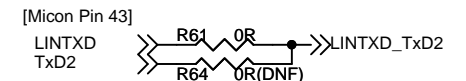
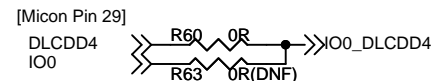
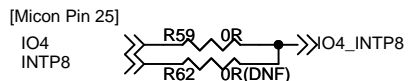
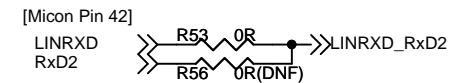
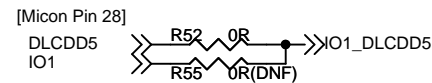
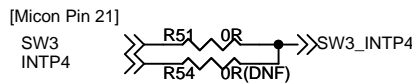

Debug LCD

Do not use if VCC is not equal to 5V.

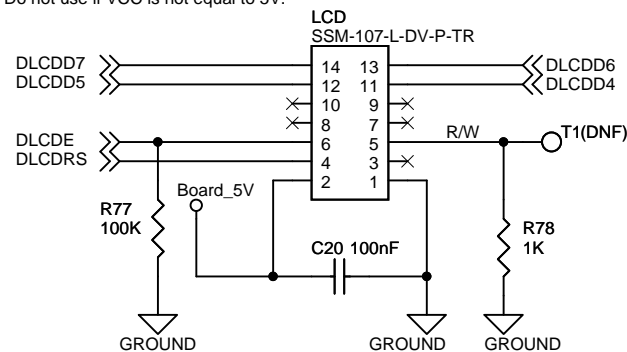

Renesas Solutions Corp.

Title		
RSKRL78G13 [Application Headers, Micon Pin Function Select, Debug LCD]		
Size	Document Number	Rev
A4	R20UT0458EG0101	1.01
Date:	Thursday, June 30, 2011	Sheet 5 of 7

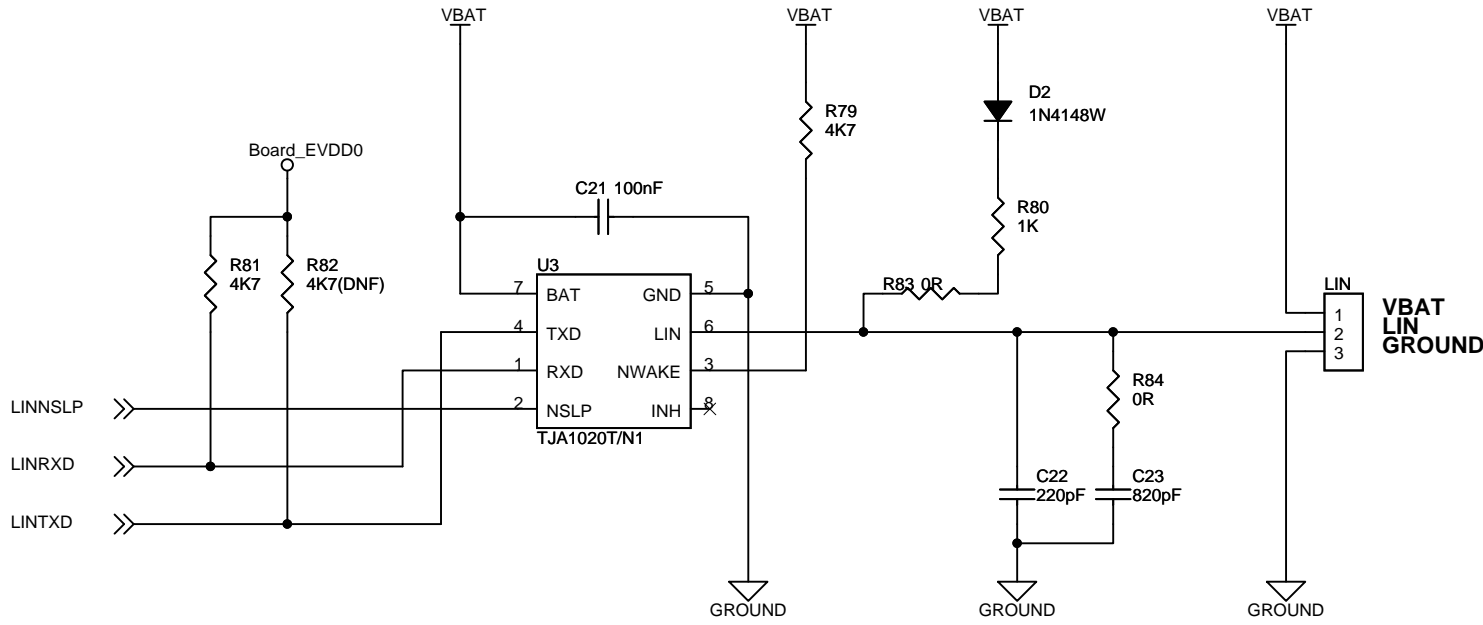

LIN Mode Select	Fitted	Removed
R83,R84	Master	Slave

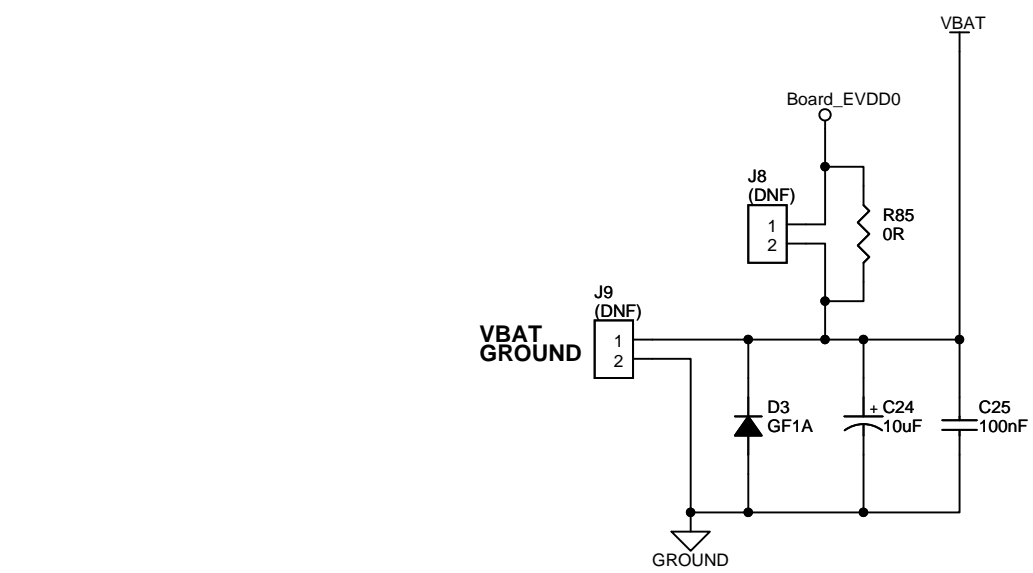

Warning:
 As for default setting, Board_EVDD0 is supplied to VBAT via R85.
 When external power is supplied to VBAT, please be sure to remove R85.

Renesas Solutions Corp.		
Title RSKRL78G13 [LIN]		
Size A4	Document Number R2OUT0458EG0101	Rev 1.01
Date: Thursday, June 30, 2011	Sheet 7	of 7