

To our customers,

Old Company Name in Catalogs and Other Documents

On April 1st, 2010, NEC Electronics Corporation merged with Renesas Technology Corporation, and Renesas Electronics Corporation took over all the business of both companies. Therefore, although the old company name remains in this document, it is a valid Renesas Electronics document. We appreciate your understanding.

Renesas Electronics website: <http://www.renesas.com>

April 1st, 2010
Renesas Electronics Corporation

Issued by: Renesas Electronics Corporation (<http://www.renesas.com>)

Send any inquiries to <http://www.renesas.com/inquiry>.

Notice

1. All information included in this document is current as of the date this document is issued. Such information, however, is subject to change without any prior notice. Before purchasing or using any Renesas Electronics products listed herein, please confirm the latest product information with a Renesas Electronics sales office. Also, please pay regular and careful attention to additional and different information to be disclosed by Renesas Electronics such as that disclosed through our website.
2. Renesas Electronics does not assume any liability for infringement of patents, copyrights, or other intellectual property rights of third parties by or arising from the use of Renesas Electronics products or technical information described in this document. No license, express, implied or otherwise, is granted hereby under any patents, copyrights or other intellectual property rights of Renesas Electronics or others.
3. You should not alter, modify, copy, or otherwise misappropriate any Renesas Electronics product, whether in whole or in part.
4. Descriptions of circuits, software and other related information in this document are provided only to illustrate the operation of semiconductor products and application examples. You are fully responsible for the incorporation of these circuits, software, and information in the design of your equipment. Renesas Electronics assumes no responsibility for any losses incurred by you or third parties arising from the use of these circuits, software, or information.
5. When exporting the products or technology described in this document, you should comply with the applicable export control laws and regulations and follow the procedures required by such laws and regulations. You should not use Renesas Electronics products or the technology described in this document for any purpose relating to military applications or use by the military, including but not limited to the development of weapons of mass destruction. Renesas Electronics products and technology may not be used for or incorporated into any products or systems whose manufacture, use, or sale is prohibited under any applicable domestic or foreign laws or regulations.
6. Renesas Electronics has used reasonable care in preparing the information included in this document, but Renesas Electronics does not warrant that such information is error free. Renesas Electronics assumes no liability whatsoever for any damages incurred by you resulting from errors in or omissions from the information included herein.
7. Renesas Electronics products are classified according to the following three quality grades: “Standard”, “High Quality”, and “Specific”. The recommended applications for each Renesas Electronics product depends on the product’s quality grade, as indicated below. You must check the quality grade of each Renesas Electronics product before using it in a particular application. You may not use any Renesas Electronics product for any application categorized as “Specific” without the prior written consent of Renesas Electronics. Further, you may not use any Renesas Electronics product for any application for which it is not intended without the prior written consent of Renesas Electronics. Renesas Electronics shall not be in any way liable for any damages or losses incurred by you or third parties arising from the use of any Renesas Electronics product for an application categorized as “Specific” or for which the product is not intended where you have failed to obtain the prior written consent of Renesas Electronics. The quality grade of each Renesas Electronics product is “Standard” unless otherwise expressly specified in a Renesas Electronics data sheets or data books, etc.
 - “Standard”: Computers; office equipment; communications equipment; test and measurement equipment; audio and visual equipment; home electronic appliances; machine tools; personal electronic equipment; and industrial robots.
 - “High Quality”: Transportation equipment (automobiles, trains, ships, etc.); traffic control systems; anti-disaster systems; anti-crime systems; safety equipment; and medical equipment not specifically designed for life support.
 - “Specific”: Aircraft; aerospace equipment; submersible repeaters; nuclear reactor control systems; medical equipment or systems for life support (e.g. artificial life support devices or systems), surgical implantations, or healthcare intervention (e.g. excision, etc.), and any other applications or purposes that pose a direct threat to human life.
8. You should use the Renesas Electronics products described in this document within the range specified by Renesas Electronics, especially with respect to the maximum rating, operating supply voltage range, movement power voltage range, heat radiation characteristics, installation and other product characteristics. Renesas Electronics shall have no liability for malfunctions or damages arising out of the use of Renesas Electronics products beyond such specified ranges.
9. Although Renesas Electronics endeavors to improve the quality and reliability of its products, semiconductor products have specific characteristics such as the occurrence of failure at a certain rate and malfunctions under certain use conditions. Further, Renesas Electronics products are not subject to radiation resistance design. Please be sure to implement safety measures to guard them against the possibility of physical injury, and injury or damage caused by fire in the event of the failure of a Renesas Electronics product, such as safety design for hardware and software including but not limited to redundancy, fire control and malfunction prevention, appropriate treatment for aging degradation or any other appropriate measures. Because the evaluation of microcomputer software alone is very difficult, please evaluate the safety of the final products or system manufactured by you.
10. Please contact a Renesas Electronics sales office for details as to environmental matters such as the environmental compatibility of each Renesas Electronics product. Please use Renesas Electronics products in compliance with all applicable laws and regulations that regulate the inclusion or use of controlled substances, including without limitation, the EU RoHS Directive. Renesas Electronics assumes no liability for damages or losses occurring as a result of your noncompliance with applicable laws and regulations.
11. This document may not be reproduced or duplicated, in any form, in whole or in part, without prior written consent of Renesas Electronics.
12. Please contact a Renesas Electronics sales office if you have any questions regarding the information contained in this document or Renesas Electronics products, or if you have any other inquiries.

(Note 1) “Renesas Electronics” as used in this document means Renesas Electronics Corporation and also includes its majority-owned subsidiaries.

(Note 2) “Renesas Electronics product(s)” means any product developed or manufactured by or for Renesas Electronics.

Renesas Starter Kit2+ for SH7216

Software Manual

RENESAS SINGLE-CHIP MICROCOMPUTER
SuperH FAMILY

Disclaimer

This software is supplied by Renesas Technology Corp. and is only intended for use with Renesas products. No other uses are authorized.

This software is owned by Renesas Technology Corp. and is protected under all applicable laws, including copyright laws.

THIS SOFTWARE IS PROVIDED "AS IS" AND RENESAS MAKES NO WARRANTIES REGARDING THIS SOFTWARE, WHETHER EXPRESS, IMPLIED OR STATUTORY, INCLUDING BUT NOT LIMITED TO WARRANTIES OF MERCHANTABILITY, FITNESS FOR A PARTICULAR PURPOSE AND NON-INFRINGEMENT. ALL SUCH WARRANTIES ARE EXPRESSLY DISCLAIMED.

TO THE MAXIMUM EXTENT PERMITTED NOT PROHIBITED BY LAW, NEITHER RENESAS TECHNOLOGY CORP. NOR ANY OF ITS AFFILIATED COMPANIES SHALL BE LIABLE FOR ANY DIRECT, INDIRECT, SPECIAL, INCIDENTAL OR CONSEQUENTIAL DAMAGES FOR ANY REASON RELATED TO THE THIS SOFTWARE, EVEN IF RENESAS OR ITS AFFILIATES HAVE BEEN ADVISED OF THE POSSIBILITY OF SUCH DAMAGES.

Renesas reserves the right, without notice, to make changes to this software and to discontinue the availability of this software. By using this software, you agree to the additional terms and conditions found by accessing the following link:

<http://www.renesas.com/disclaimer>

Table of Contents

Chapter 1. Preface	6
Chapter 2. Introduction.....	2
Chapter 3. RSK Sample Code Concept.....	3
3.1. List of Sample code	4
3.1.1. Tutorial	5
3.1.1.1. Sequence Diagram	6
3.1.1.2. Description	7
3.1.2. ADC_OneShot	8
3.1.2.1. Sequence Diagram	8
3.1.2.2. Description	8
3.1.3. ADC_Repeat	9
3.1.3.1. Sequence Diagram	9
3.1.3.2. Description	9
3.1.4. Async_Serial	10
3.1.4.1. Sequence Diagram	10
3.1.4.2. Description	11
3.1.5. Watchdog_Timer	12
3.1.5.1. Sequence Diagram	12
3.1.5.2. Description	13
3.1.6. DMAC	14
3.1.6.1. Sequence Diagram	14
3.1.6.2. Description	15
3.1.7. Timer_Mode	16
3.1.7.1. Sequence Diagram	16
3.1.7.2. Description	17
3.1.8. Timer_Event.....	18
3.1.8.1. Sequence Diagram	18
3.1.8.2. Description	19
3.1.9. Timer_Capture	20
3.1.9.1. Sequence Diagram	20
3.1.9.2. Description	21
3.1.10. Timer_Compare	22
3.1.10.1. Sequence Diagram	22
3.1.10.2. Description	23
3.1.11. BSC	24
3.1.11.1. Sequence Diagram.....	24
3.1.11.2. Description.....	25
3.1.12. DTC.....	26

3.1.12.1. Sequence Diagram	26
3.1.12.2. Description	27
3.1.13. Flash API.....	28
3.1.13.1. Sequence Diagram	28
3.1.13.2. Description	29
3.1.14. Flash Suspend.....	30
3.1.14.1. Sequence Diagram	30
3.1.14.2. Description	31
3.1.15. Sync_Serial.....	32
3.1.15.1. Sequence Diagram	32
3.1.15.2. Description	32
Chapter 4. Additional Information.....	33

Table of Figures

Figure 1 RSK Sample Code.....3
Figure 2 Functions used in Tutorial code.....5
Figure 3 Tutorial Sequence Diagram.....6
Figure 4 ADC_OneShot Sequence Diagram.....8
Figure 5 ADC_Repeat Sequence Diagram.....9
Figure 6 Serial_Uart Sequence Diagram.....10
Figure 7 Watchdog_Timer Sequence Diagram.....12
Figure 8 DMAC Sequence Diagram.....14
Figure 9 Timer_Mode Sequence Diagram.....16
Figure 10: Timer_Event Sequence Diagram.....18
Figure 11: Timer_Capture Sequence Diagram.....20
Figure 12: Timer_Compare Sequence Diagram.....22
Figure 13: BSC Sequence Diagram.....24
Figure 14: DTC Sequence Diagram.....26
Figure 15: Flash API Sequence Diagram.....28
Figure 16: Flash Suspend Sequence Diagram.....30
Figure 17: Sync_Serial Sequence Diagram.....32

Chapter 1. Preface

Cautions

This document may be, wholly or partially, subject to change without notice.

All rights reserved. Duplication of this document, either in whole or part is prohibited without the written permission of Renesas Technology Europe Limited.

Trademarks

All brand or product names used in this manual are trademarks or registered trademarks of their respective companies or organisations.

Copyright

© 2010 Renesas Technology Europe Ltd. All rights reserved.

© 2010 Renesas Technology Corporation. All rights reserved.

© 2010 Renesas Solutions Corporation. All rights reserved.

Website: www.renesas.com

Glossary

ADC	Analogue / Digital Converter	HEW	High performance Embedded Workshop
API	Application Programming Interface	I/O	Input / Output
CMT	Compare Match Timer	RSK	Renesas Starter Kit
CPG	Clock Pulse Generator	WDT	Watchdog Timer
DMAC	Direct Memory Access Controller		

Chapter 2. Introduction

This document explains the sample code for the RSK Renesas Starter Kit.

It explains by text and diagrams the outline functionality of the sample code.

Chapter 3. RSK Sample Code Concept

The diagram below shows the basic structure of all the RSK sample code:

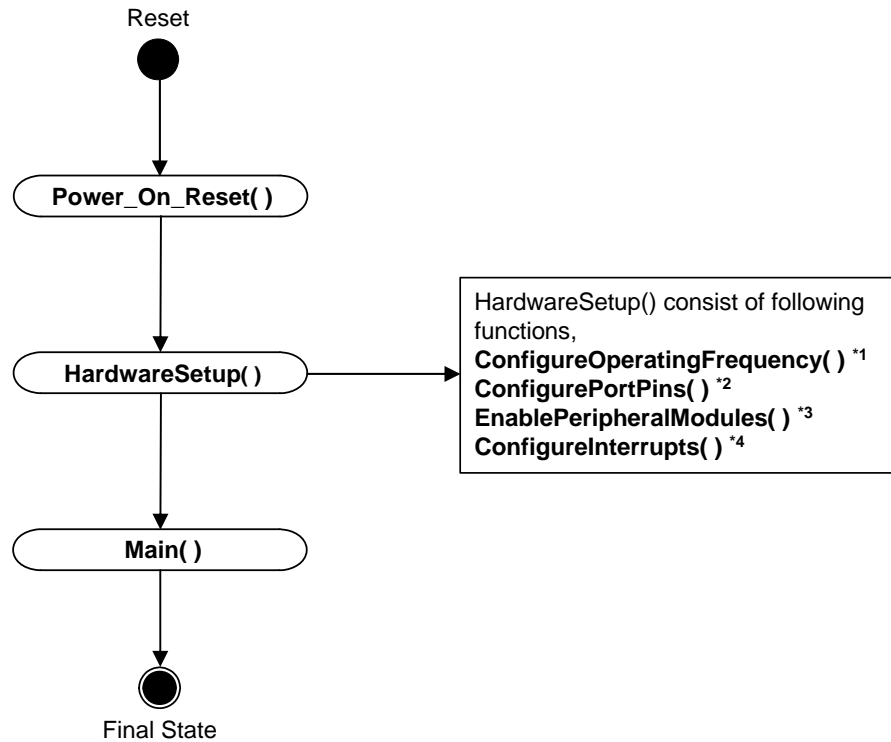

Figure 1 RSK Sample Code

Note:

- 1- This function initialises the CPU main clock, the real time clock and the PLL.
- 2- This function configures the CPU port pins as input and output. It also determines the initial state of the output port pin.
- 3- This function enables or disables the peripheral modules of the CPU.
- 4- This function configures the CPU interrupts.

3.1. List of Sample code

You can click on the sample code title for more description.

	Sample Code	Description
1	Tutorial	Demonstrates the use of debugger and hardware
2	ADC_OneShot	Demonstration of the on-chip ADC module for one shot conversion.
3	ADC_Repeat	Demonstration of the on-chip ADC module for repeat conversion.
4	Async_Serial	Demonstration of the on-chip Serial Interface module for asynchronous serial communication.
5	Watchdog_Timer	Demonstration of the on-chip watchdog timer.
6	DMAC	Demonstration of the on-chip Direct Memory Access Controller.
7	Timer_Mode	Demonstration of the on-chip Timer module to generate square waveform.
8	Timer_Event	Demonstrates of on-chip MTU2 module in event counter mode
9	Timer_Capture	Demonstrates on-chip MTU2 module in input capture mode.
10	Timer_Compare	Demonstrates on-chip CMT module in output compare mode.
11	BSC	Demonstrates the configuration of external SDRAM using Bus state control.
12	DTC	Demonstrates the use of on-chip DTC module.
13	Flash API	Demonstrates write and erase operations in flash memory.
14	Flash Suspend	Demonstrates the flash suspend operation.
15	Sync_Serial	Demonstration of the on-chip Serial Interface module for synchronous serial communication

Table 3-1 List of sample code

3.1.1. Tutorial

The tutorial demonstrates the use of the debugger and the hardware. The tutorial code is common for all RSK's.

This code will call three main functions to demonstrate port pin control, interrupt usage and C variable initialization. These functions are shown below,

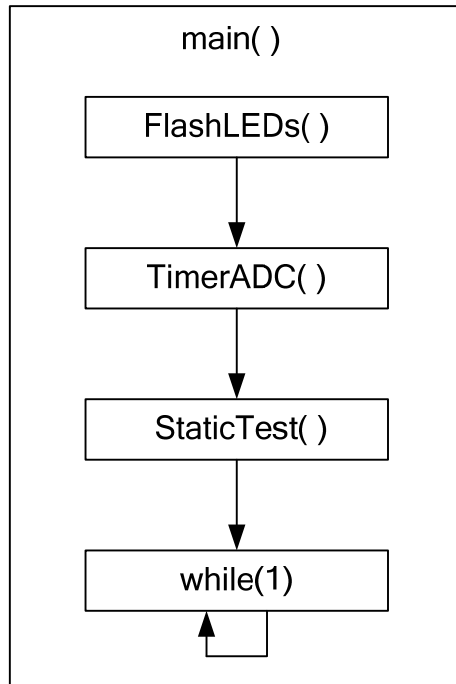

Figure 2 Functions used in Tutorial code

3.1.1.1. Sequence Diagram

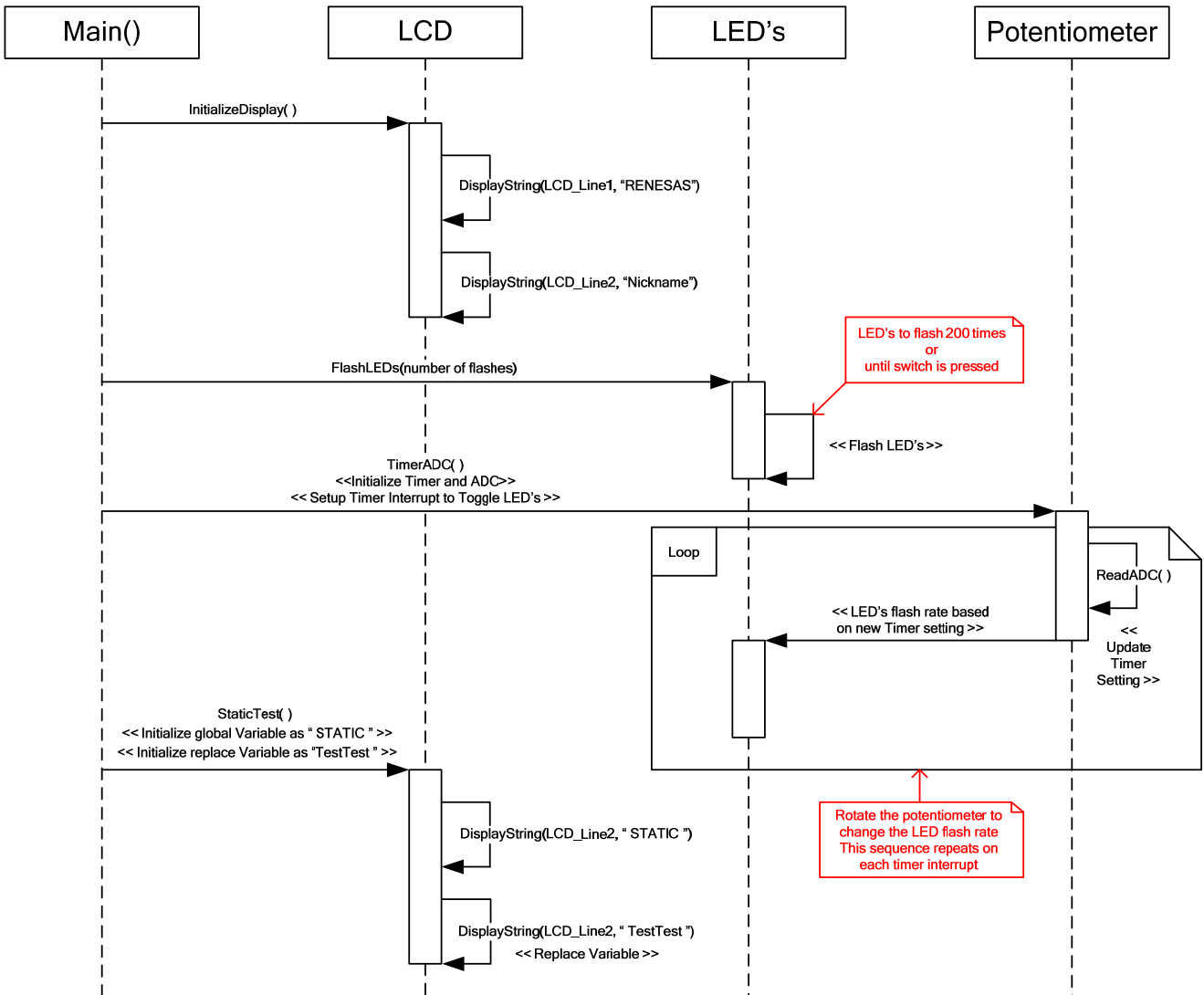

Figure 3 Tutorial Sequence Diagram

3.1.1.2. Description

- 1- The tutorial code initializes the LCD module and displays "Renesas" on Line-1 and the RSK nickname on Line-2.
- 2- All the LED's start flashing. The LED's flash 200 times or until switch is pressed.
- 3- After initial 200 flashes LED's flashing, the flash rate is now controlled by the potentiometer (RV1).
- 4- At the same time the LCD will display a variable "STATIC" which is then replaced by "TESTTEST" to demonstrate the static variable test.
- 5- The RSK nickname is displayed on the LCD after the completion of static test (step 4).

3.1.2. ADC_OneShot

This sample code demonstrates the use of on-chip ADC module for one shot conversion.

3.1.2.1. Sequence Diagram

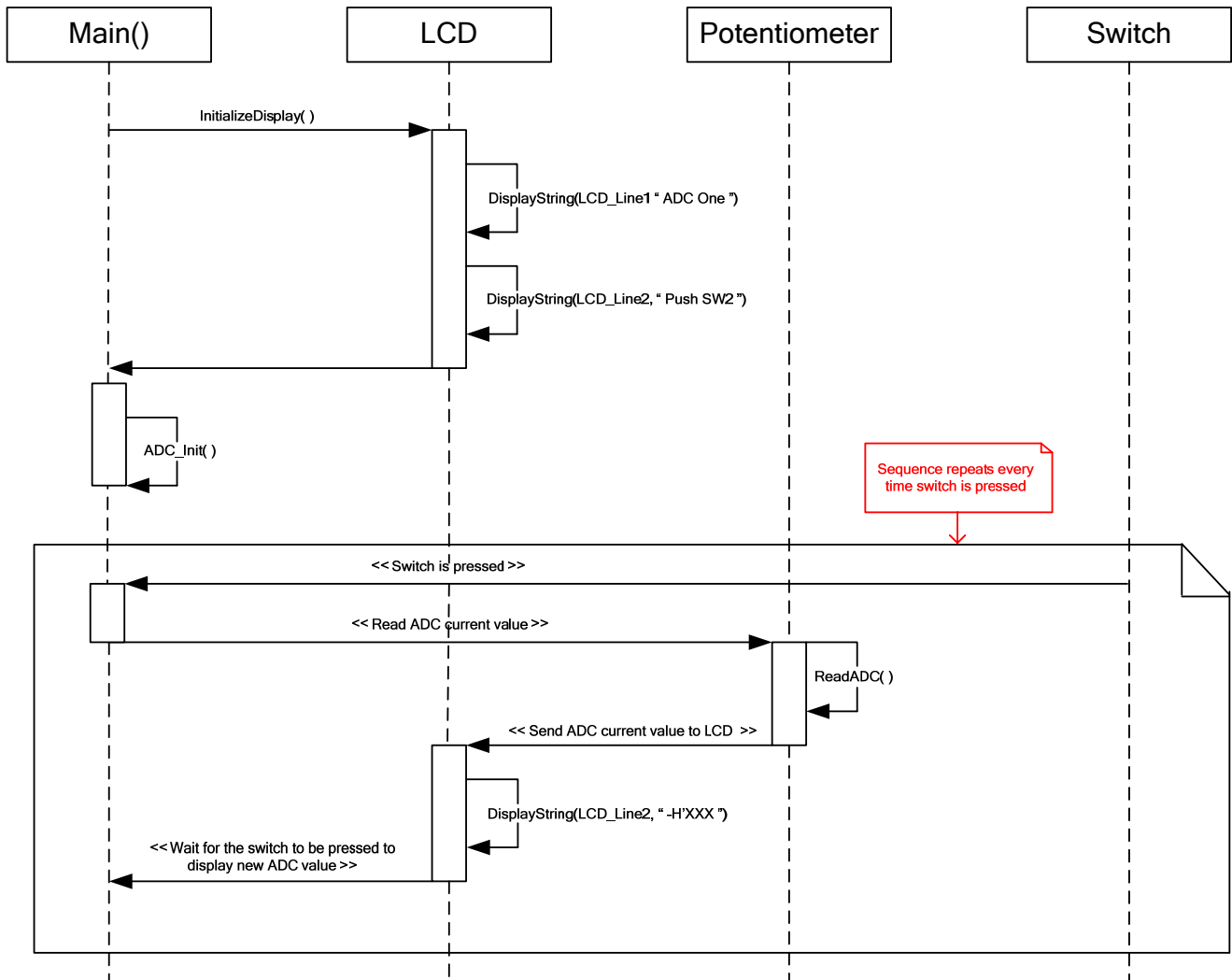

Figure 4 ADC_OneShot Sequence Diagram

3.1.2.2. Description

- 1- ADC_OneShot sample code initializes the LCD module and display "ADCOne" on Line-1 and "PushSW2" on Line-2.
- 2- The ADC channel is configured for one shot conversion.
- 3- The result is stored in the "usADC_Result" variable and user may examine the AD conversion result in "usADC_Result" using HEW C watch window.
- 4- The debug LCD also displays the result of AD conversion in hex format.
- 5- The AD conversion result is shown on LCD when switch is pressed.

3.1.3. ADC_Repeat

This sample code demonstrates the use of on-chip ADC module for repeat conversion.

3.1.3.1. Sequence Diagram

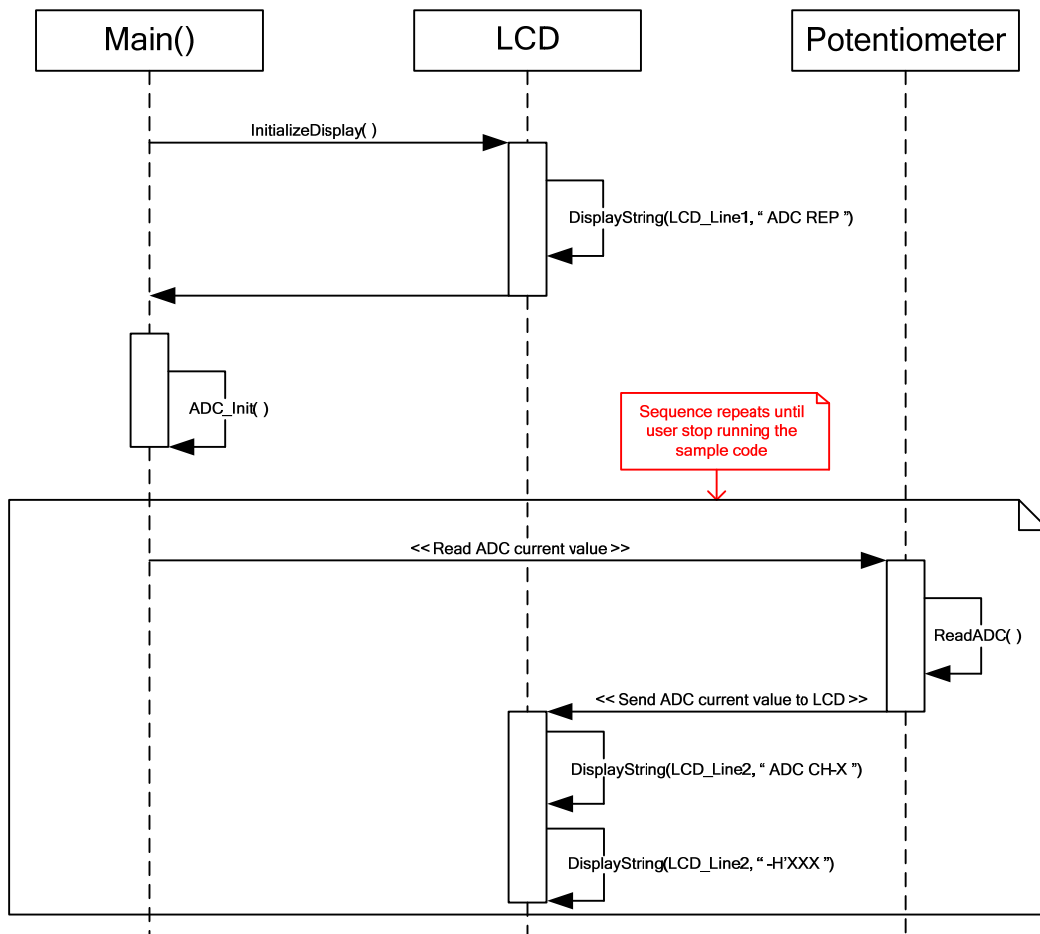

Figure 5 ADC_Repeat Sequence Diagram

3.1.3.2. Description

- 1- The ADC_Repeat sample code initializes the LCD module and displays "ADC REP" on Line-1 and AD conversion result on Line-2.
- 2- The ADC channel is configured for AD repeat conversion.
- 3- The result is stored in the "usADC_Result" variable and user may examine the AD conversion result in "usADC_Result" using HEW C watch window.
- 4- The debug LCD also displays the result of last AD conversion in hex format.

3.1.4. Async_Serial

This sample code demonstrates an asynchronous serial communication using the on-chip serial interface module.

3.1.4.1. Sequence Diagram

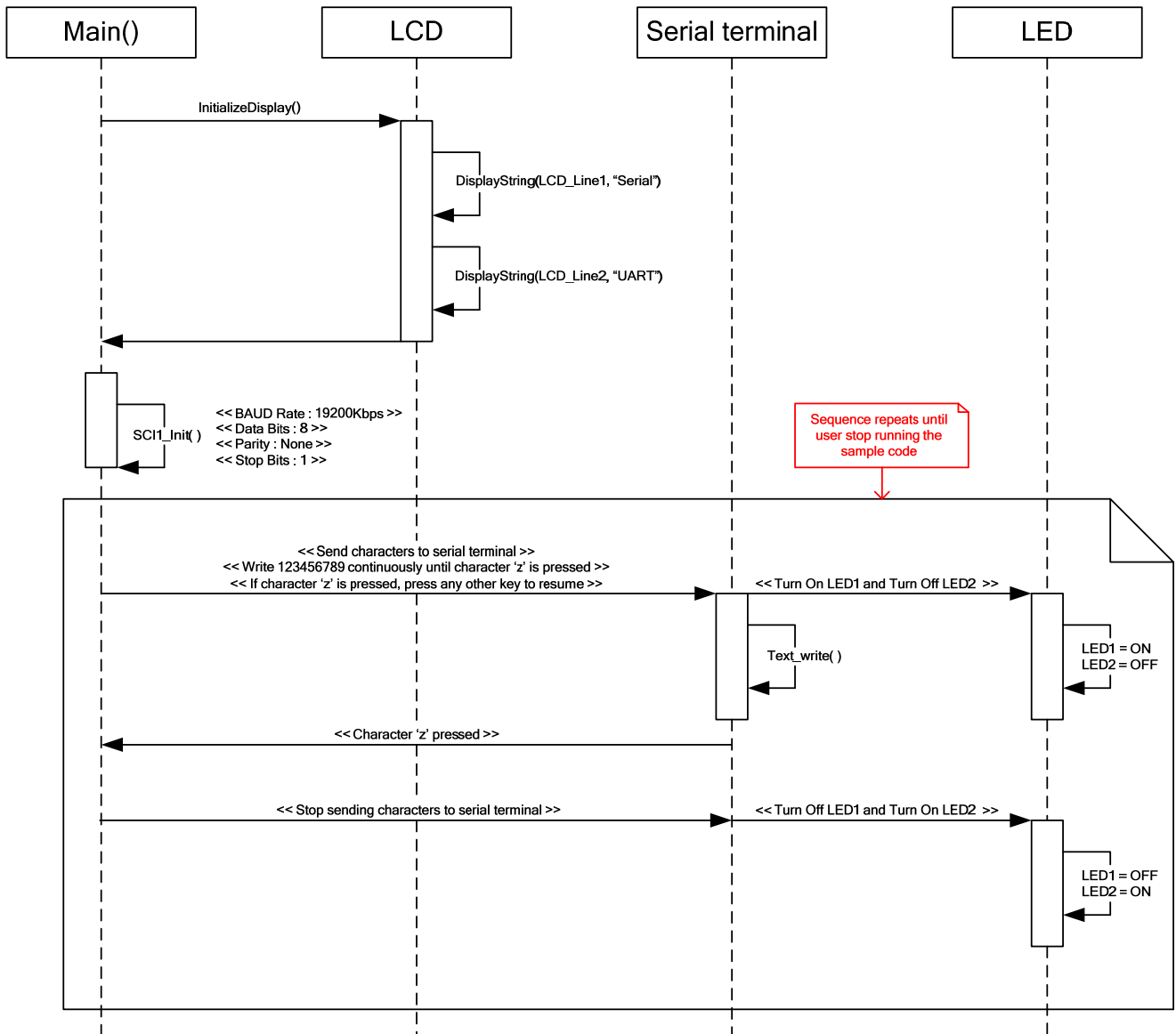

Figure 6 Serial_Uart Sequence Diagram

3.1.4.2. Description

- 1- The Serial_Uart sample code initializes the LCD module and displays "Serial" on Line-1 and "UART" on Line-2.
- 2- The serial channel is configured as: 19200bps baud rate, 8 data bits, 1 stop bit and no parity.
- 3- This code communicates with the terminal software on the PC (e.g. Hyper Terminal on Windows).
- 4- Incrementing data (0 to 9) is sent to the terminal window repeatedly.
- 5- Sending data can be stopped by pressing 'z' on the PC keyboard.
- 6- To resume, press any key other than 'z'.

3.1.5. Watchdog_Timer

This sample code demonstrates the usage of watchdog timer. The watchdog timeout period can be adjusted using the on-board analog POT (RV1).

3.1.5.1. Sequence Diagram

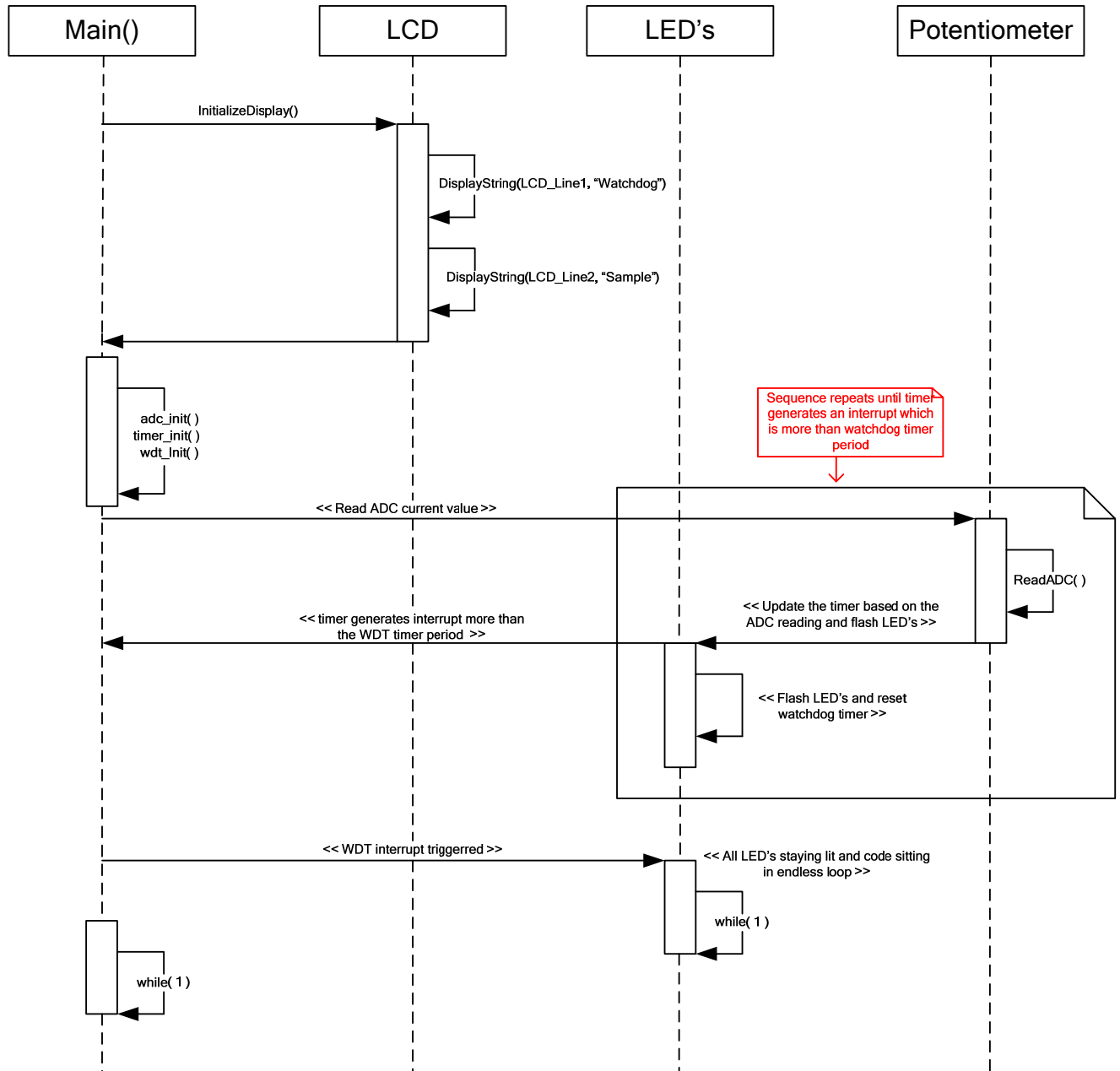

Figure 7 Watchdog_Timer Sequence Diagram

3.1.5.2. Description

- 1- The Watchdog_Timer sample code initializes the LCD module and displays "Watchdog" on Line-1 and "Sample" on Line-2.
- 2- Timer is initialised in output compare mode, and AD channel is initialised in scan mode.
- 3- The LED's will start flashing sequentially. Flash rate can be controlled by the analogue potentiometer (RV1).
- 4- Turning the analogue potentiometer clockwise or anti-clockwise will vary the speed of LED flashing and how often the watchdog timer is accessed (to prevent it from timing out).
- 5- At almost full clockwise position of analogue POT, the watchdog timer interrupt will be generated to make all LED's staying ON and code sitting in an endless loop.

3.1.6. DMAC

This sample demonstrates the direct memory access using on-chip DMA Controller.

3.1.6.1. Sequence Diagram

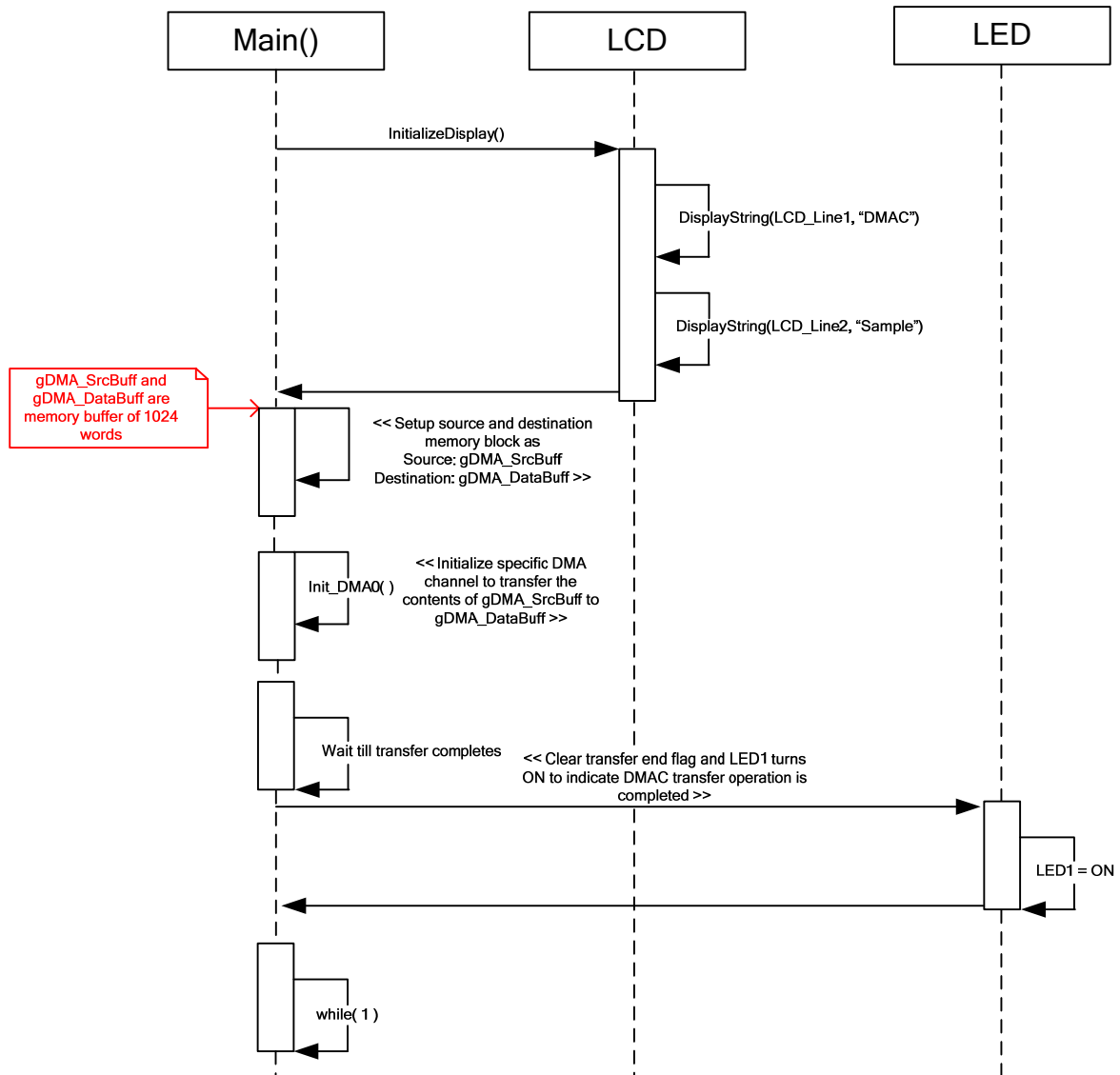

Figure 8 DMAC Sequence Diagram

3.1.6.2. Description

- 1- The DMAC sample code initializes the LCD module and displays "DMAC" on Line-1 and "Sample" on Line-2.
- 2- The source & destination buffers to default values..
- 3- This application configures DMAC with source 'gDMA_SrcBuff' and destination 'gDMA_DataBuff' as two different memory blocks of 1024 words and initializes the DMA controller for the transfer operation.
- 4- LED1 turns ON when the DMAC transfer completes.
- 5- The DMAC transfer operation result can be seen in a variable 'gDMA_DataBuff' using HEW C watch window, once LED1 turns ON.

3.1.7. Timer_Mode

This sample code configures the timer to generate 1 KHz waveform. The waveform can be seen on the oscilloscope.

3.1.7.1. Sequence Diagram

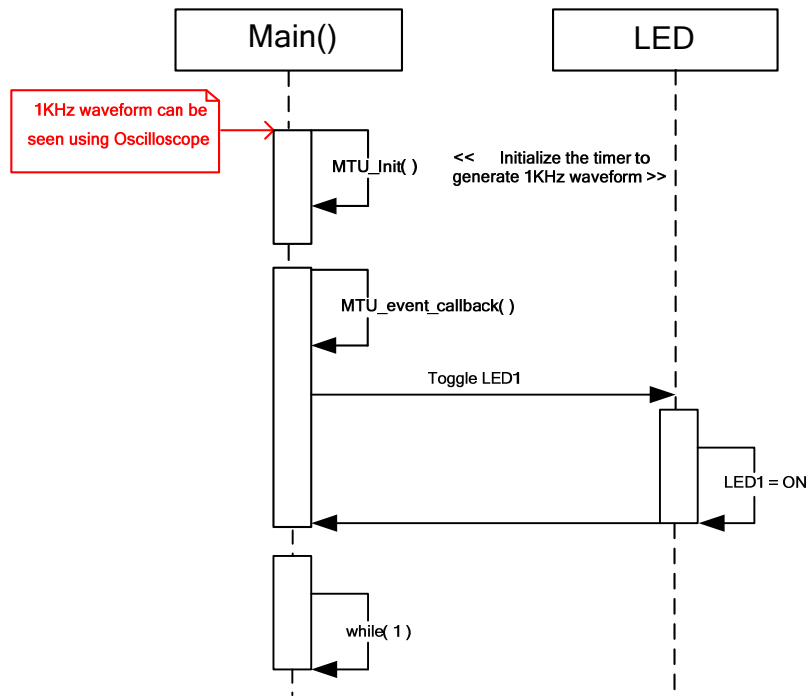

Figure 9 Timer_Mode Sequence Diagram

3.1.7.2. Description

- 1- The Timer_Mode sample code application initializes the timer to generate 1 KHz waveform on the respective timer port pin.
- 2- On every timeout, LED1-5 toggled.
- 3- The waveform can be seen using an oscilloscope.

3.1.8. Timer_Event

This sample code configures the timer to count the number of input signal events.

3.1.8.1. Sequence Diagram

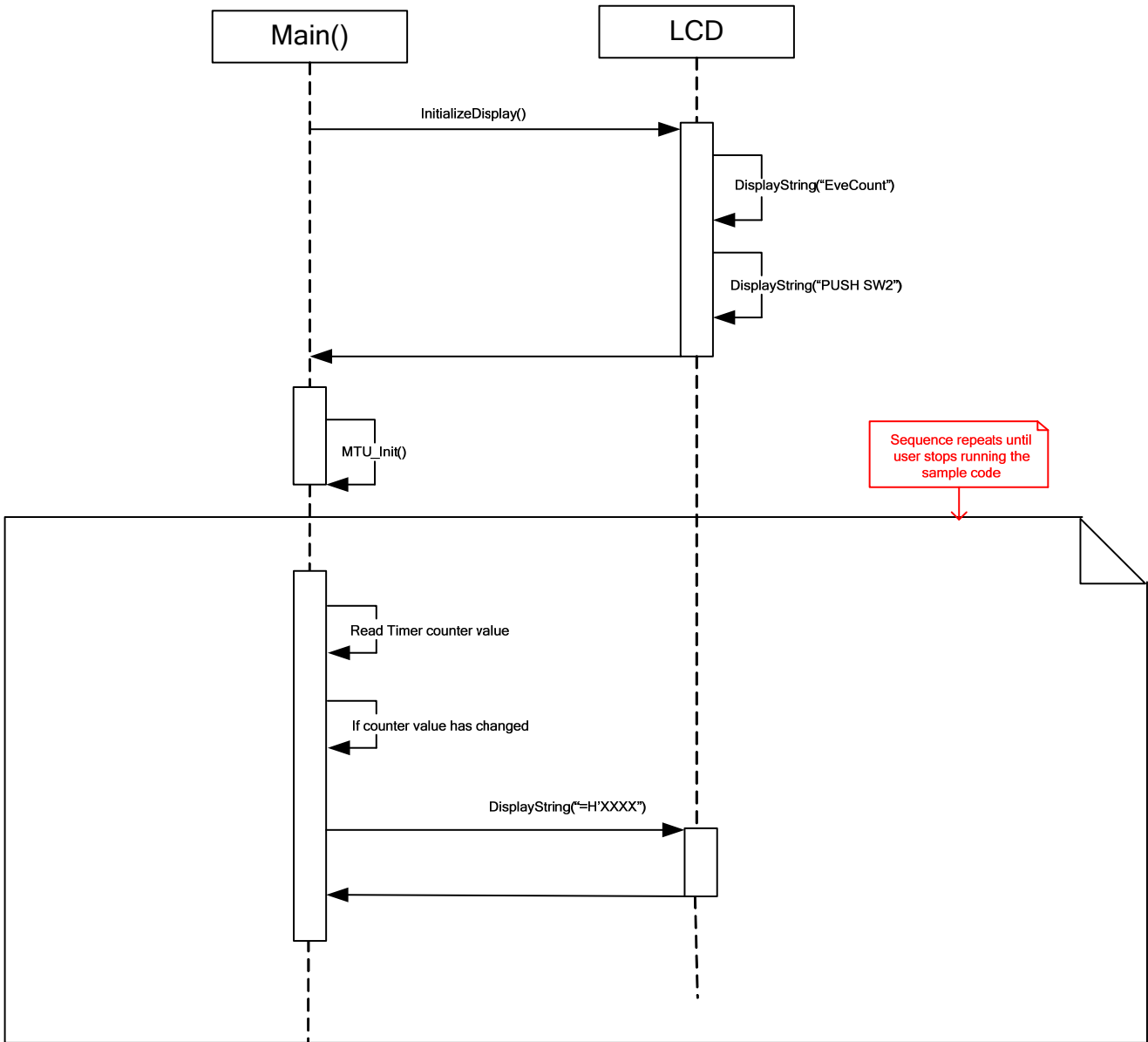

Figure 10: Timer_Event Sequence Diagram

3.1.8.2. Description

- 1- The Timer_Event initializes the timer to count user switch (SW2) press events.
- 2- On every switch (SW2) press event, the counter increments value by one unit & it is displayed on LCD.

3.1.9. Timer_Capture

This sample code configures the timer to capture timer counter's value in one of the general purpose registers, on reception of input signal at one of timer's pins.

3.1.9.1. Sequence Diagram

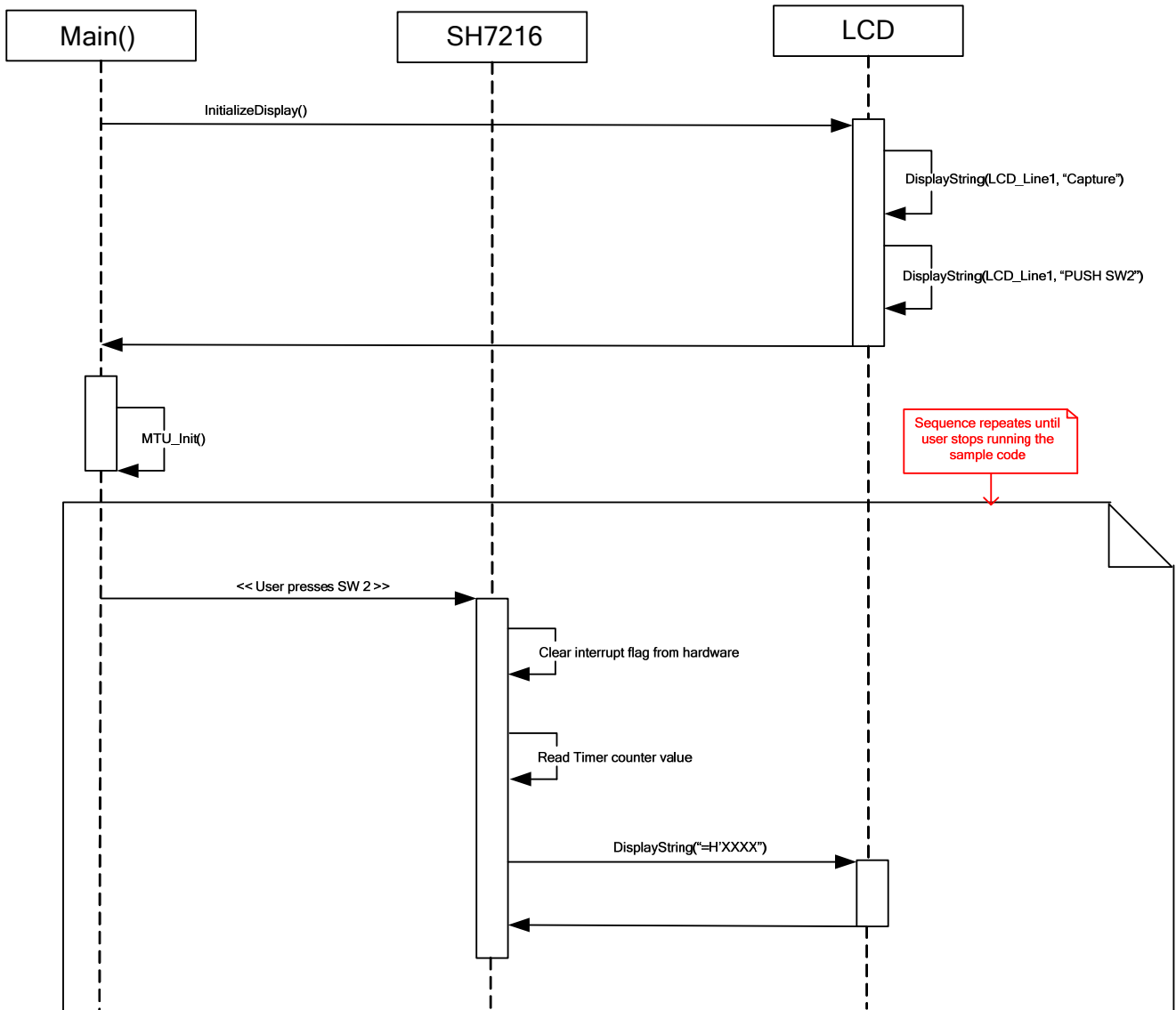

Figure 11: Timer_Capture Sequence Diagram

3.1.9.2. Description

- 1- The Timer_Capture initializes the timer to capture value of timer's counter in a general purpose register at the instant the user presses switch (SW2).
- 2- On every switch (SW2) press, it displays value of timer counter register at that instant on LCD.

3.1.10. Timer_Compare

This sample code configures the compare match timer to generate an interrupt when timer counter value matches with the one in compare match constant register.

3.1.10.1. Sequence Diagram

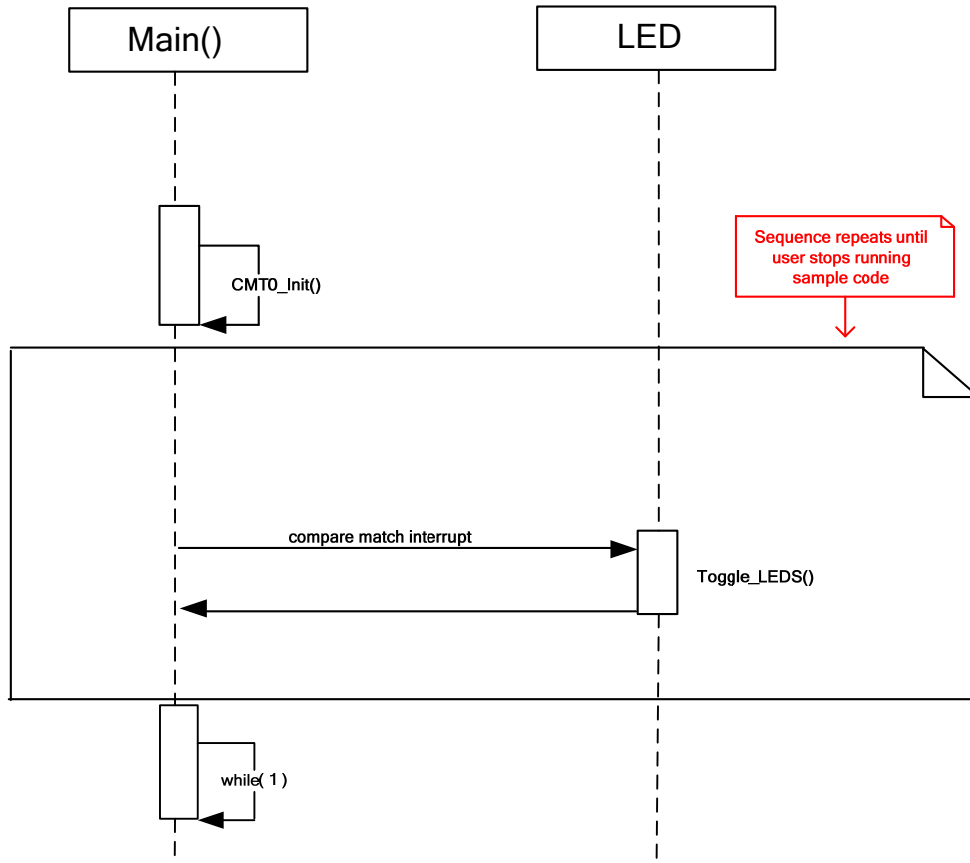

Figure 12: Timer_Compare Sequence Diagram

3.1.10.2. Description

- 1- The Timer_Compare initializes the compare match timer to generate an interrupt when timer counter value matches the value in compare match constant register.
- 2- The interrupt service routine toggles LED's whenever it is executed.

3.1.11. BSC

This sample code uses Bus State Controller to transfer data from RAM to SDRAM.

3.1.11.1. Sequence Diagram

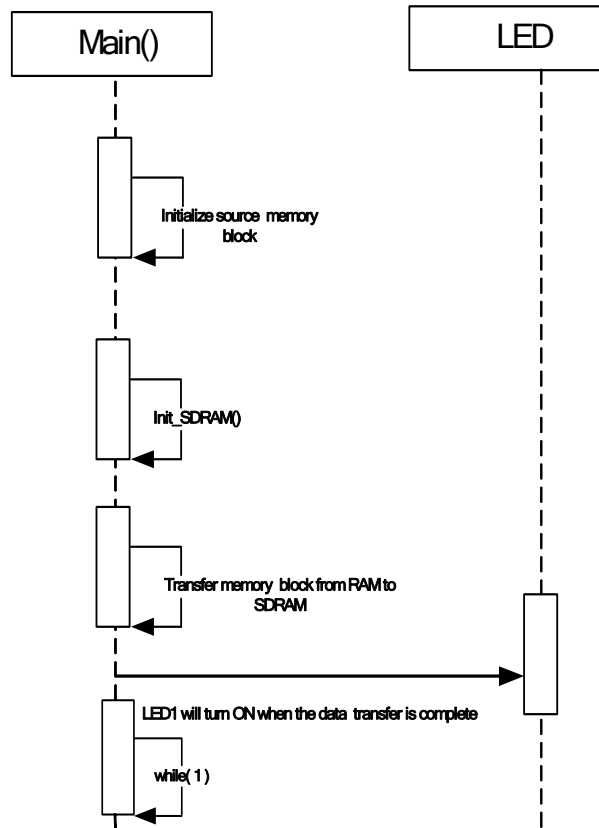

Figure 13: BSC Sequence Diagram

3.1.11.2. Description

- 1- The BSC sample application initializes SDRAM interface.
- 2- The application transfers data initialized in RAM to SDRAM.
- 3- Once the transfer is complete, LED1 turns ON. The transferred block can be verified using HEW C watch window after LED1 is turned ON.

3.1.12. DTC

This sample code demonstrates the use of on-chip DTC module.

3.1.12.1. Sequence Diagram

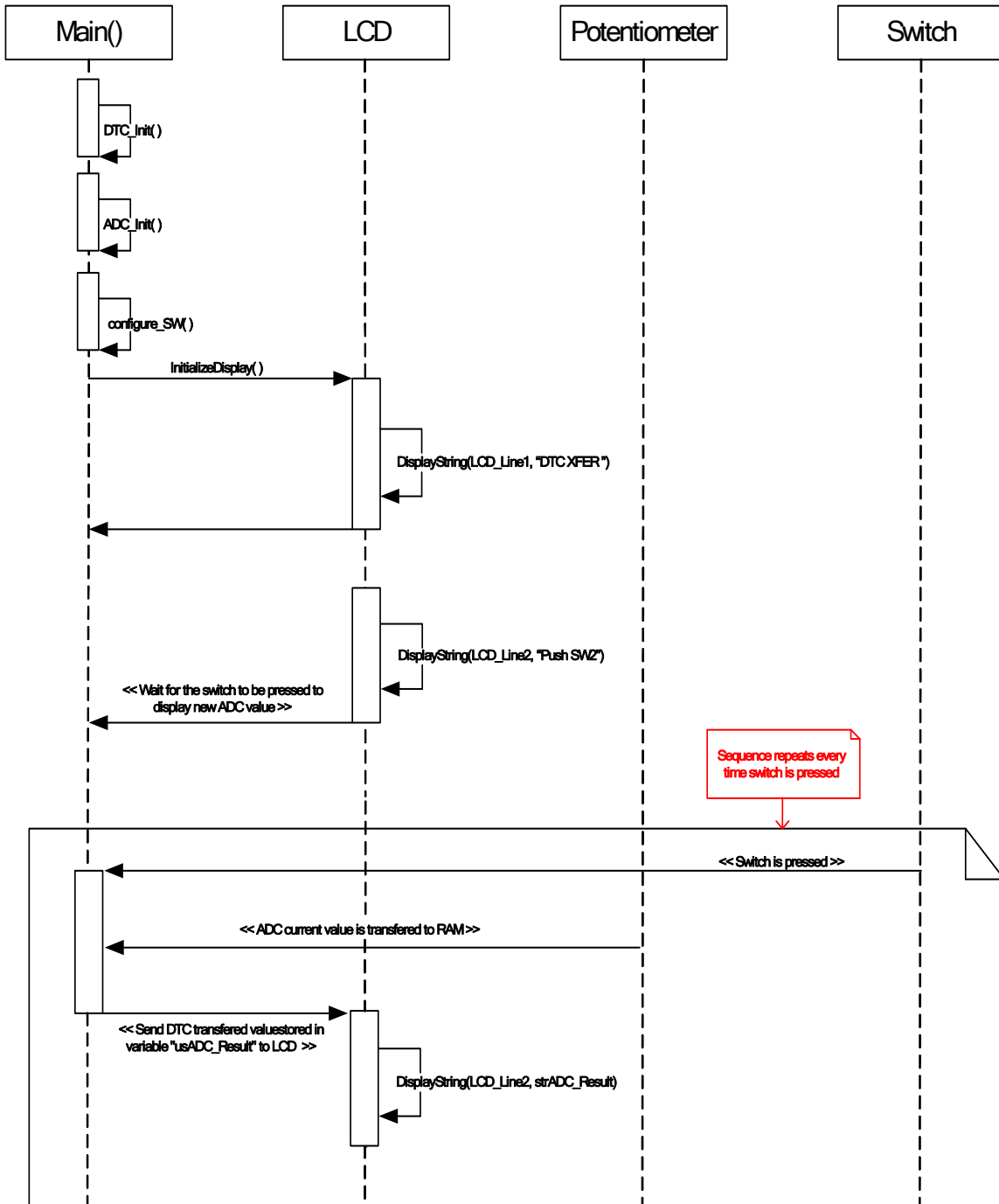

Figure 14: DTC Sequence Diagram

3.1.12.2.Description

- 1- DTC sample code initializes the LCD module and displays "DTC XFER" on Line-1 and "PushSW2" on Line-2.
- 2- The ADC channel is configured for one shot conversion.
- 3- If switch is pressed DTC trigger is generated.
- 4- The ADC result is transferred to the destination address in "usADC_Result_arr" variable and user may examine the AD conversion result in "usADC_Result_arr" using HEW C watch window.
- 5- The debug LCD also displays the result of DTC transfer in hex format.
- 6- The DTC transfer result is shown on LCD when switch is pressed.

3.1.13. Flash API

The application demonstrates write and erase operations in flash memory.

3.1.13.1. Sequence Diagram

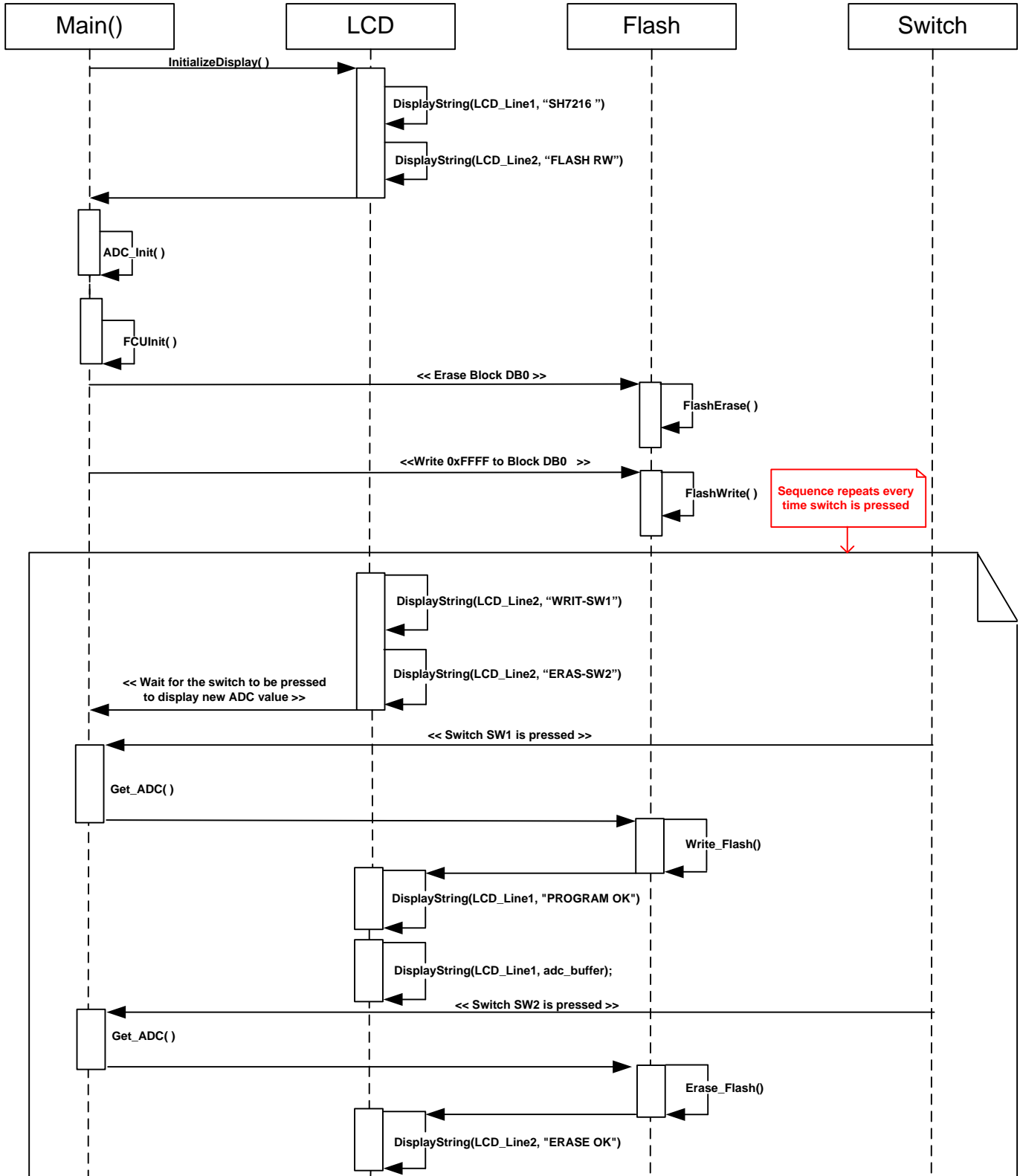

Figure 15: Flash API Sequence Diagram

3.1.13.2.Description

- 1- Flash API sample code initializes the LCD module and displays "FLASH RW " on Line-2.
- 2- The ADC is configured in one shot mode and Flash is initialised.
- 3- Flash erase and Flash write with H'FFFF data is executed.
- 4- If SW1 is pressed, the Flash write operation is executed and ADC value read is written to Block DB1.
- 5- If SW2 is pressed, the Flash erase operation is executed on Block DB1.

3.1.14. Flash Suspend

The application demonstrates the flash suspend operation.

3.1.14.1. Sequence Diagram

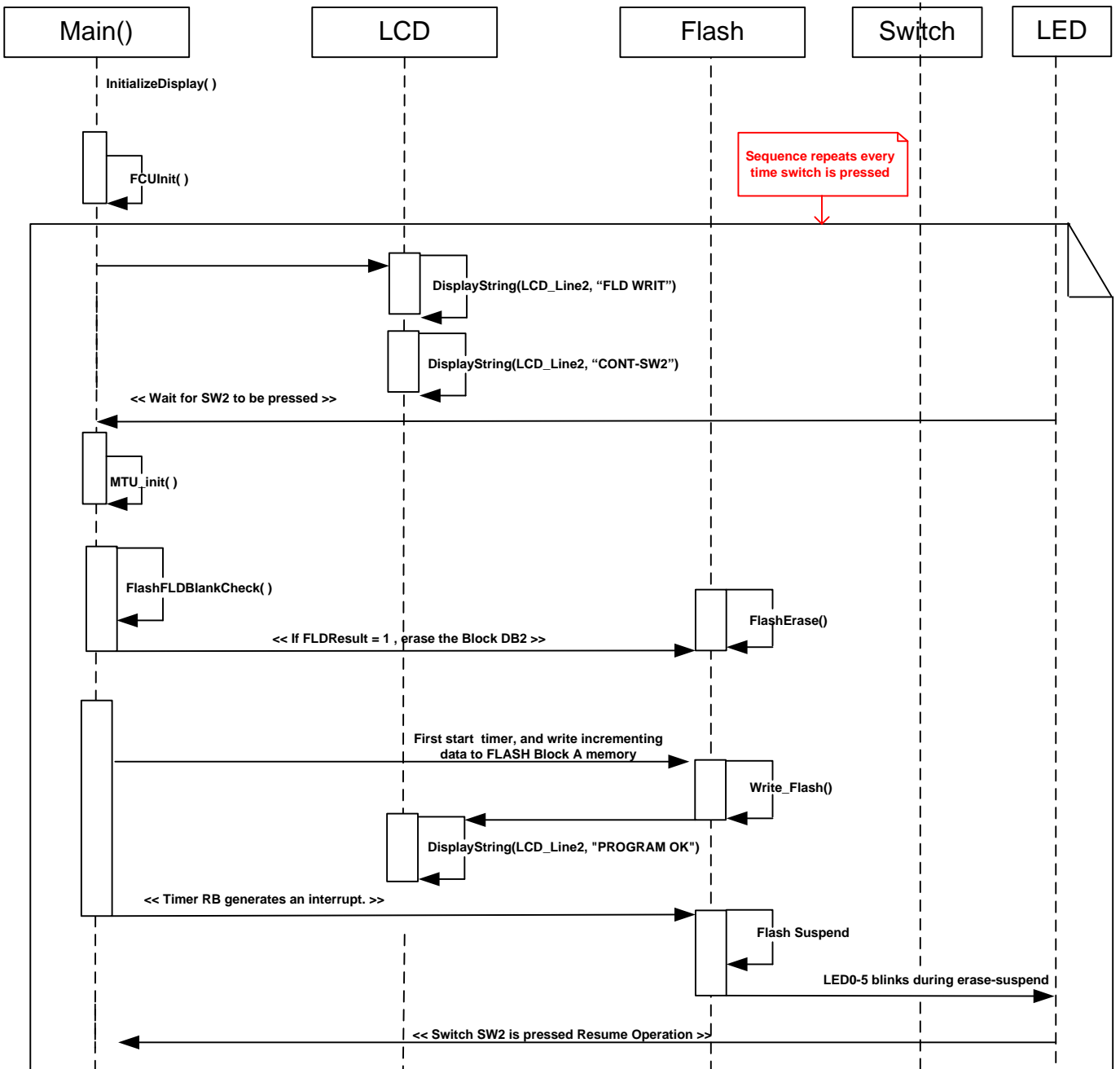

Figure 16: Flash Suspend Sequence Diagram

3.1.14.2. Description

- 1- Flash suspend sample code initializes the LCD module and displays "FLD WRIT" on Line-1 and "CONT-SW2" on Line-2.
- 2- The Flash is initialised.
- 3- When SW2 is pressed, the MTU is configured in timer mode and a blank check on the block is performed.
- 4- If blank check fails, the block is erased.
- 5- The block is initialised by writing an incrementing data to the block.
- 6- Flash write suspend occurs once the timer interrupt occurs and partial block remains blank due to suspend.
- 7- When user presses switch SW2, the write operation is resumed again.

3.1.15. Sync_Serial

This sample code demonstrates a synchronous serial communication using on-chip serial interface module.

3.1.15.1. Sequence Diagram

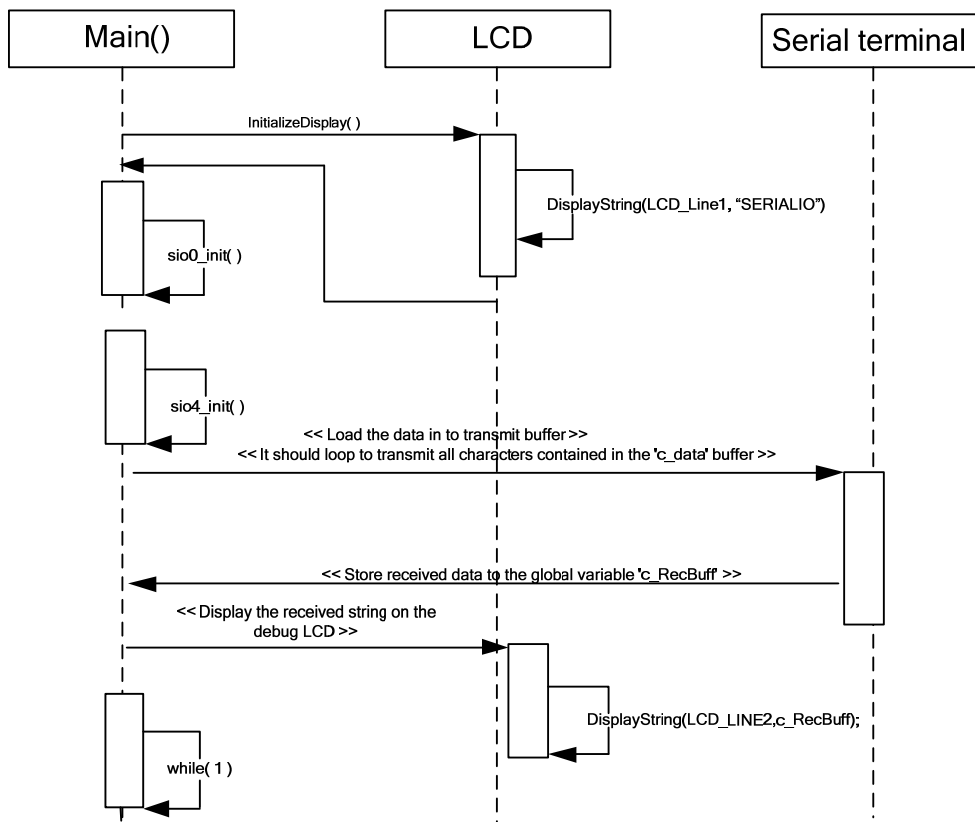

Figure 17: Sync_Serial Sequence Diagram

3.1.15.2. Description

- 1- The Sync_serial sample code initializes LCD module and displays "SERIALIO" on Line-1.
- 2- The serial channel is configured for synchronous data communication.
 - a. SCI4 is configured as transmitter and
 - b. SCI0 is configured as receiver.
- 3- Transmitter sends the serial data to the receiver port, synchronised with the clock.
- 4- The received data should match with the transmitted data string.
- 5- Successful reception is displayed on the LCD.

Chapter 4. Additional Information

For details on how to use High-performance Embedded Workshop (HEW), refer to the HEW manual available on the CD or installed in the Manual Navigator.

For information about the SH7216 microcontrollers refer to the *SH7216 Group Hardware Manual*

For information about the SH7216 assembly language, refer to the *SH-2A SH2A-FPU Software Manual*

For information about the E10A Emulator, please refer to the *E10A-USB Emulator User's Manual*

Online technical support and information is available at: www.renesas.com/renesas_starter_kits

Technical Contact Details

America: techsupport.rta@renesas.com

Europe: tools.support.eu@renesas.com

Japan: csc@renesas.com

General information on Renesas Microcontrollers can be found on the Renesas website at: www.renesas.com

Renesas Starter Kit2+ for SH7216

Software Manual

Publication Date Rev.1.0 4.FEB.2010

Published by: Renesas Technology Europe Ltd.
Duke's Meadow, Millboard Road, Bourne End
Buckinghamshire SL8 5FH, United Kingdom

©2009 Renesas Technology Europe and Renesas Solutions Corp., All Rights Reserved.

Renesas Starter Kit2+ for SH7216 Software Manual



Renesas Electronics Corporation

1753, Shimonumabe, Nakahara-ku, Kawasaki-shi, Kanagawa 211-8668 Japan

REG10J0170-0100