

To our customers,

Old Company Name in Catalogs and Other Documents

On April 1st, 2010, NEC Electronics Corporation merged with Renesas Technology Corporation, and Renesas Electronics Corporation took over all the business of both companies. Therefore, although the old company name remains in this document, it is a valid Renesas Electronics document. We appreciate your understanding.

Renesas Electronics website: <http://www.renesas.com>

April 1st, 2010
Renesas Electronics Corporation

Issued by: Renesas Electronics Corporation (<http://www.renesas.com>)

Send any inquiries to <http://www.renesas.com/inquiry>.

Notice

1. All information included in this document is current as of the date this document is issued. Such information, however, is subject to change without any prior notice. Before purchasing or using any Renesas Electronics products listed herein, please confirm the latest product information with a Renesas Electronics sales office. Also, please pay regular and careful attention to additional and different information to be disclosed by Renesas Electronics such as that disclosed through our website.
2. Renesas Electronics does not assume any liability for infringement of patents, copyrights, or other intellectual property rights of third parties by or arising from the use of Renesas Electronics products or technical information described in this document. No license, express, implied or otherwise, is granted hereby under any patents, copyrights or other intellectual property rights of Renesas Electronics or others.
3. You should not alter, modify, copy, or otherwise misappropriate any Renesas Electronics product, whether in whole or in part.
4. Descriptions of circuits, software and other related information in this document are provided only to illustrate the operation of semiconductor products and application examples. You are fully responsible for the incorporation of these circuits, software, and information in the design of your equipment. Renesas Electronics assumes no responsibility for any losses incurred by you or third parties arising from the use of these circuits, software, or information.
5. When exporting the products or technology described in this document, you should comply with the applicable export control laws and regulations and follow the procedures required by such laws and regulations. You should not use Renesas Electronics products or the technology described in this document for any purpose relating to military applications or use by the military, including but not limited to the development of weapons of mass destruction. Renesas Electronics products and technology may not be used for or incorporated into any products or systems whose manufacture, use, or sale is prohibited under any applicable domestic or foreign laws or regulations.
6. Renesas Electronics has used reasonable care in preparing the information included in this document, but Renesas Electronics does not warrant that such information is error free. Renesas Electronics assumes no liability whatsoever for any damages incurred by you resulting from errors in or omissions from the information included herein.
7. Renesas Electronics products are classified according to the following three quality grades: “Standard”, “High Quality”, and “Specific”. The recommended applications for each Renesas Electronics product depends on the product’s quality grade, as indicated below. You must check the quality grade of each Renesas Electronics product before using it in a particular application. You may not use any Renesas Electronics product for any application categorized as “Specific” without the prior written consent of Renesas Electronics. Further, you may not use any Renesas Electronics product for any application for which it is not intended without the prior written consent of Renesas Electronics. Renesas Electronics shall not be in any way liable for any damages or losses incurred by you or third parties arising from the use of any Renesas Electronics product for an application categorized as “Specific” or for which the product is not intended where you have failed to obtain the prior written consent of Renesas Electronics. The quality grade of each Renesas Electronics product is “Standard” unless otherwise expressly specified in a Renesas Electronics data sheets or data books, etc.
 - “Standard”: Computers; office equipment; communications equipment; test and measurement equipment; audio and visual equipment; home electronic appliances; machine tools; personal electronic equipment; and industrial robots.
 - “High Quality”: Transportation equipment (automobiles, trains, ships, etc.); traffic control systems; anti-disaster systems; anti-crime systems; safety equipment; and medical equipment not specifically designed for life support.
 - “Specific”: Aircraft; aerospace equipment; submersible repeaters; nuclear reactor control systems; medical equipment or systems for life support (e.g. artificial life support devices or systems), surgical implantations, or healthcare intervention (e.g. excision, etc.), and any other applications or purposes that pose a direct threat to human life.
8. You should use the Renesas Electronics products described in this document within the range specified by Renesas Electronics, especially with respect to the maximum rating, operating supply voltage range, movement power voltage range, heat radiation characteristics, installation and other product characteristics. Renesas Electronics shall have no liability for malfunctions or damages arising out of the use of Renesas Electronics products beyond such specified ranges.
9. Although Renesas Electronics endeavors to improve the quality and reliability of its products, semiconductor products have specific characteristics such as the occurrence of failure at a certain rate and malfunctions under certain use conditions. Further, Renesas Electronics products are not subject to radiation resistance design. Please be sure to implement safety measures to guard them against the possibility of physical injury, and injury or damage caused by fire in the event of the failure of a Renesas Electronics product, such as safety design for hardware and software including but not limited to redundancy, fire control and malfunction prevention, appropriate treatment for aging degradation or any other appropriate measures. Because the evaluation of microcomputer software alone is very difficult, please evaluate the safety of the final products or system manufactured by you.
10. Please contact a Renesas Electronics sales office for details as to environmental matters such as the environmental compatibility of each Renesas Electronics product. Please use Renesas Electronics products in compliance with all applicable laws and regulations that regulate the inclusion or use of controlled substances, including without limitation, the EU RoHS Directive. Renesas Electronics assumes no liability for damages or losses occurring as a result of your noncompliance with applicable laws and regulations.
11. This document may not be reproduced or duplicated, in any form, in whole or in part, without prior written consent of Renesas Electronics.
12. Please contact a Renesas Electronics sales office if you have any questions regarding the information contained in this document or Renesas Electronics products, or if you have any other inquiries.

(Note 1) “Renesas Electronics” as used in this document means Renesas Electronics Corporation and also includes its majority-owned subsidiaries.

(Note 2) “Renesas Electronics product(s)” means any product developed or manufactured by or for Renesas Electronics.

Renesas Starter Kit for RX610

User's Manual

Renesas 32-Bit Microcomputer
RX Family/RX600 Series

Disclaimer

By using this Renesas Starter Kit (RSK), the user accepts the following terms. The RSK is not guaranteed to be error free, and the entire risk as to the results and performance of the RSK is assumed by the User. The RSK is provided by Renesas on an "as is" basis without warranty of any kind whether express or implied, including but not limited to the implied warranties of satisfactory quality, fitness for a particular purpose, title and non-infringement of intellectual property rights with regard to the RSK. Renesas expressly disclaims all such warranties. Renesas or its affiliates shall in no event be liable for any loss of profit, loss of data, loss of contract, loss of business, damage to reputation or goodwill, any economic loss, any reprogramming or recall costs (whether the foregoing losses are direct or indirect) nor shall Renesas or its affiliates be liable for any other direct or indirect special, incidental or consequential damages arising out of or in relation to the use of this RSK, even if Renesas or its affiliates have been advised of the possibility of such damages.

Precautions

This Renesas Starter Kit is only intended for use in a laboratory environment under ambient temperature and humidity conditions. A safe separation distance should be used between this and any sensitive equipment. Its use outside the laboratory, classroom, study area or similar such area invalidates conformity with the protection requirements of the Electromagnetic Compatibility Directive and could lead to prosecution.

The product generates, uses, and can radiate radio frequency energy and may cause harmful interference to radio communications. However, there is no guarantee that interference will not occur in a particular installation. If this equipment causes harmful interference to radio or television reception, which can be determined by turning the equipment off or on, you are encouraged to try to correct the interference by one or more of the following measures;

- ensure attached cables do not lie across the equipment
- reorient the receiving antenna
- increase the distance between the equipment and the receiver
- connect the equipment into an outlet on a circuit different from that which the receiver is connected
- power down the equipment when not in use
- consult the dealer or an experienced radio/TV technician for help NOTE: It is recommended that wherever possible shielded interface cables are used.

The product is potentially susceptible to certain EMC phenomena. To mitigate against them it is recommended that the following measures be undertaken;

- The user is advised that mobile phones should not be used within 10m of the product when in use.
- The user is advised to take ESD precautions when handling the equipment.

The Renesas Starter Kit does not represent an ideal reference design for an end product and does not fulfil the regulatory standards for an end product.

Table of Contents

Chapter 1. Preface	4
Chapter 2. Purpose	5
Chapter 3. Power Supply	6
3.1. Requirements	6
3.2. Power – Up Behaviour.....	6
Chapter 4. Board Layout.....	7
4.1. Component Layout.....	7
4.2. Board Dimensions	8
Chapter 5. Block Diagram.....	9
Chapter 6. User Circuitry	11
6.1. Switches.....	11
6.2. LEDs	11
6.3. Potentiometer.....	12
6.4. Serial port.....	12
6.5. Debug LCD Module.....	13
6.6. Option Links.....	14
6.7. Oscillator Sources	16
6.8. Reset Circuit.....	16
Chapter 7. Modes.....	17
Chapter 8. Programming Methods	18
Chapter 9. Headers.....	19
9.1. Application Headers.....	19
9.2. Microcontroller Ring Headers	24
Chapter 10. Code Development	28
10.1. Overview.....	28
10.2. Compiler Restrictions	28
10.3. Mode Support	28
10.4. Breakpoint Support	28
10.5. Memory Map	29
10.6. Component Placement.....	30
Chapter 11. Additional Information	31

Chapter 1. Preface

Cautions

This document may be, wholly or partially, subject to change without notice.

All rights reserved. Duplication of this document, either in whole or part is prohibited without the written permission of Renesas Technology Europe Limited.

Trademarks

All brand or product names used in this manual are trademarks or registered trademarks of their respective companies or organisations.

Copyright

© 2010 Renesas Technology Europe Ltd. All rights reserved.

© 2010 Renesas Technology Corporation. All rights reserved.

© 2010 Renesas Solutions Corporation. All rights reserved.

Website: <http://www.eu.renesas.com/>

Glossary

CPU	Central Processing Unit	E20	On-chip debugger module
EMC	Electromagnetic compatibility	ESD	Electrostatic Discharge
HEW	High-performance Embedded Workshop	LED	Light Emitting Diode
NC	No Connection	PC	Program Counter
RSK	Renesas Starter Kit		

Chapter 2. Purpose

This RSK is an evaluation tool for Renesas microcontrollers.

This manual describes the technical details of the RSK hardware. The Quick Start Guide and Tutorial Manual provide details of the software installation and debugging environment.

Features include:

- Renesas Microcontroller Programming.
- User Code Debugging.
- User Circuitry such as Switches, LEDs and potentiometer.
- User or Example Application.
- Sample peripheral device initialisation code.

The RSK board contains all the circuitry required for microcontroller operation.

Chapter 3. Power Supply

3.1. Requirements

This RSK operates from a 5V power supply.

A diode provides reverse polarity protection only if a current limiting power supply is used.

All RSK boards are supplied with an E1 debugger. This product is able to power the RSK board with up to 200mA. When the RSK is connected to another system then that system should supply power to the RSK.

All RSK boards have an optional centre positive supply connector using a 2.0mm barrel power jack.

Warning

The RSK is neither under nor over voltage protected. Use a centre positive supply for this board.

3.2. Power – Up Behaviour

When the RSK is purchased the RSK board has the 'Release' or stand alone code from the example tutorial code pre-programmed into the Renesas microcontroller. On powering up the board the user LEDs will start to flash. After 200 flashes, or after pressing a switch the LEDs will flash at a rate controlled by the potentiometer.

Chapter 4. Board Layout

4.1. Component Layout

The following diagram shows top layer component layout of the board.

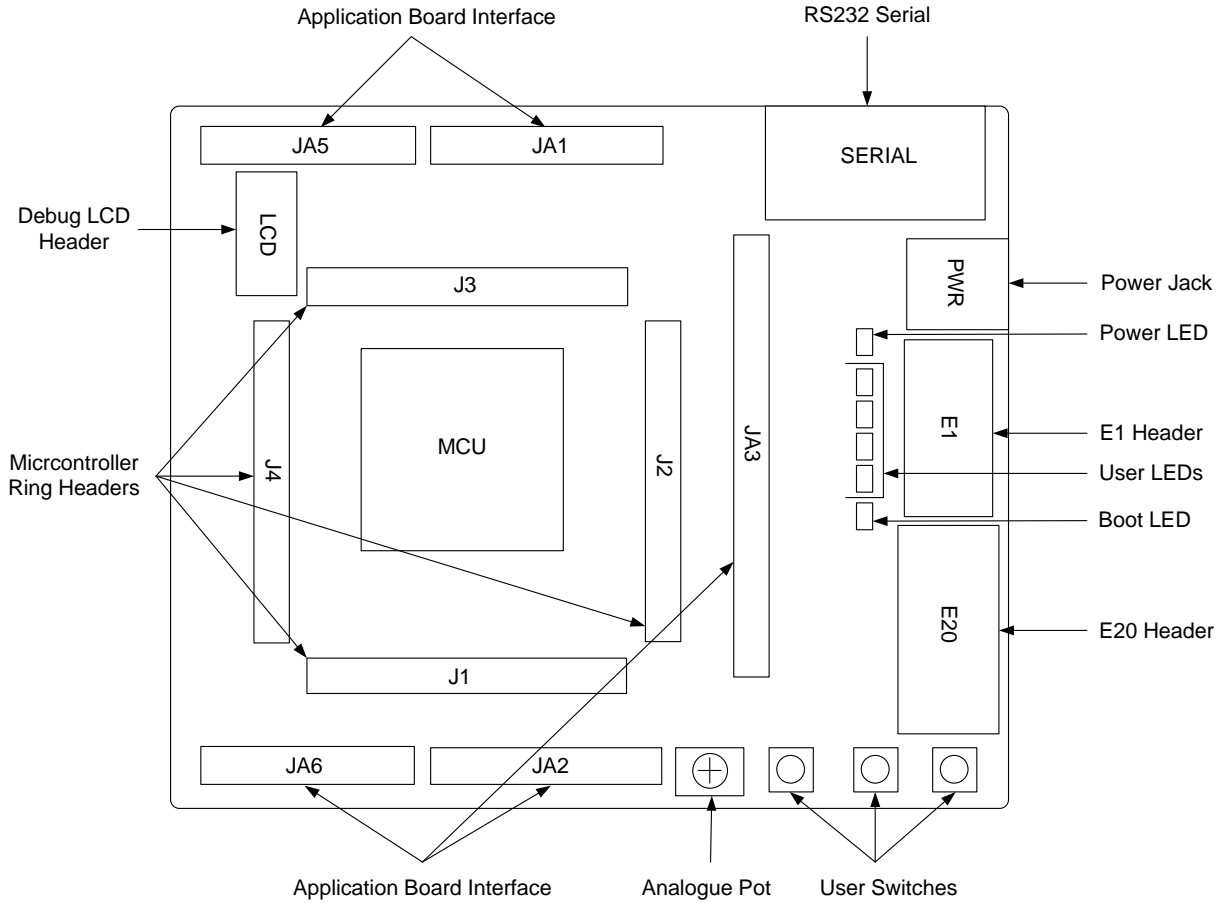

Figure 4-1: Board Layout

4.2. Board Dimensions

The following diagram gives the board dimensions and connector positions. All through hole connectors are on a common 0.1" grid for easy interfacing.

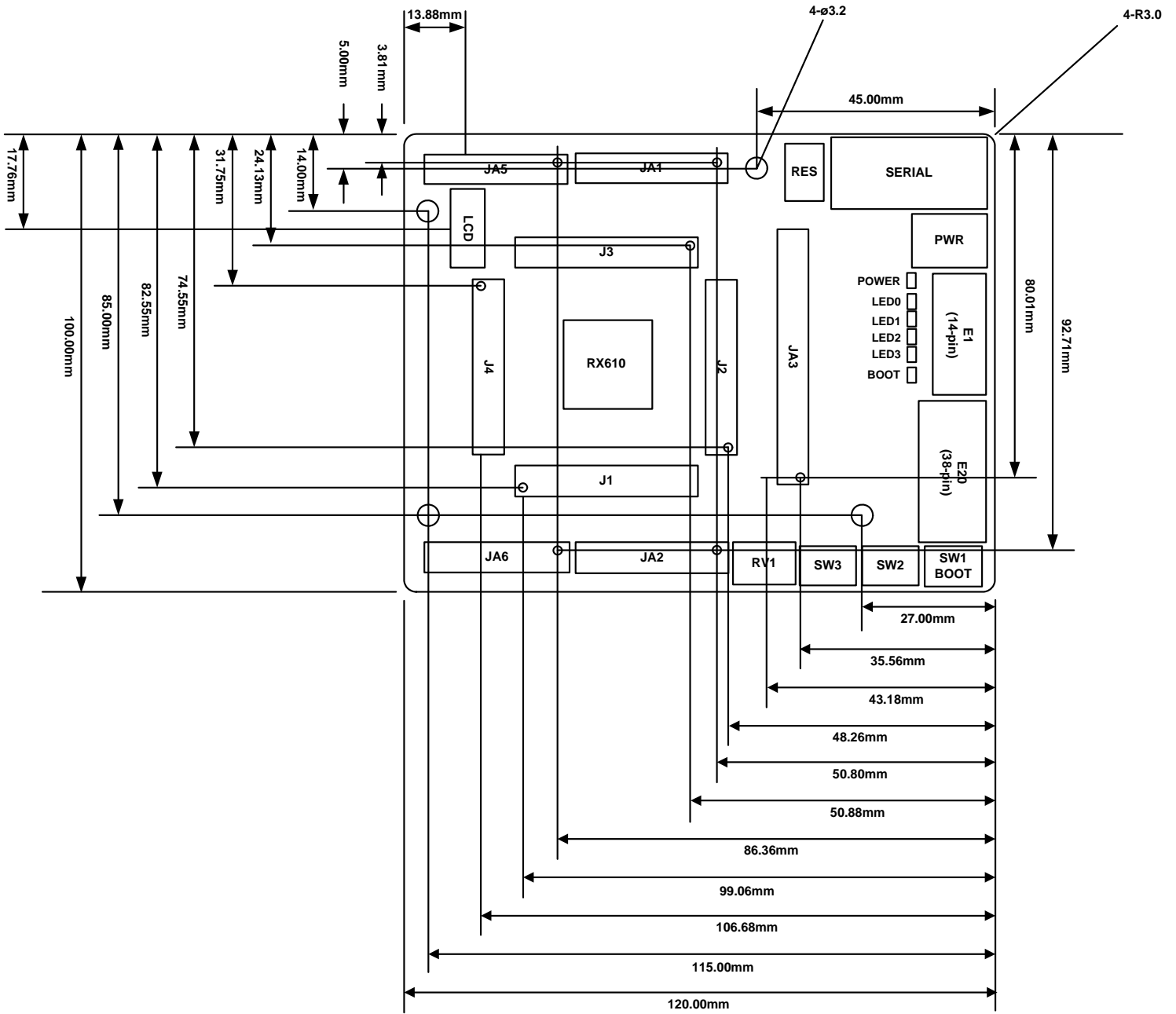

Figure 4-2: Board Dimensions

Chapter 5. Block Diagram

Figure 5-1 shows the CPU board components and their connectivity.

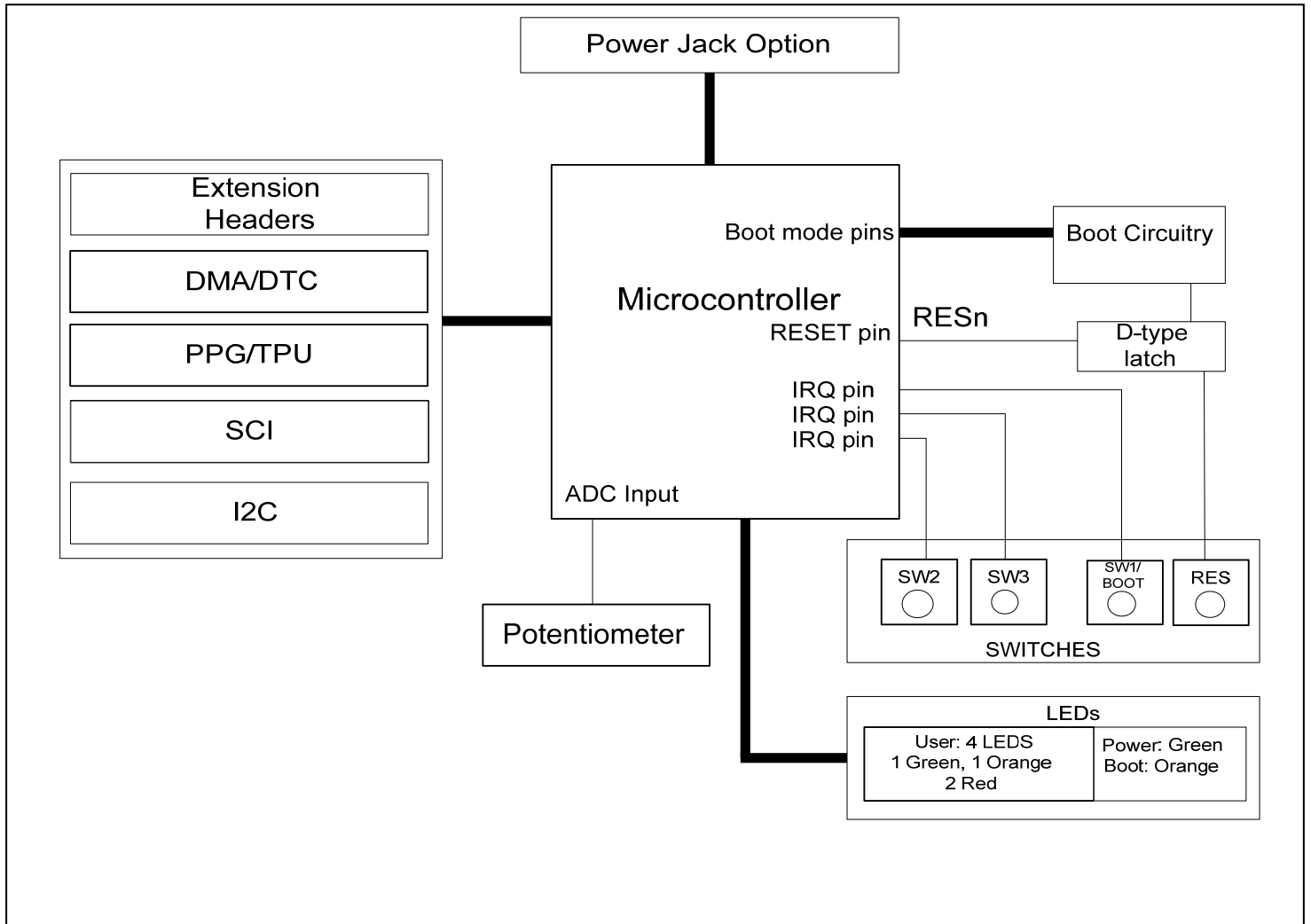

Figure 5-1: Block Diagram

Figure 5-2 shows the connections to the RSK.

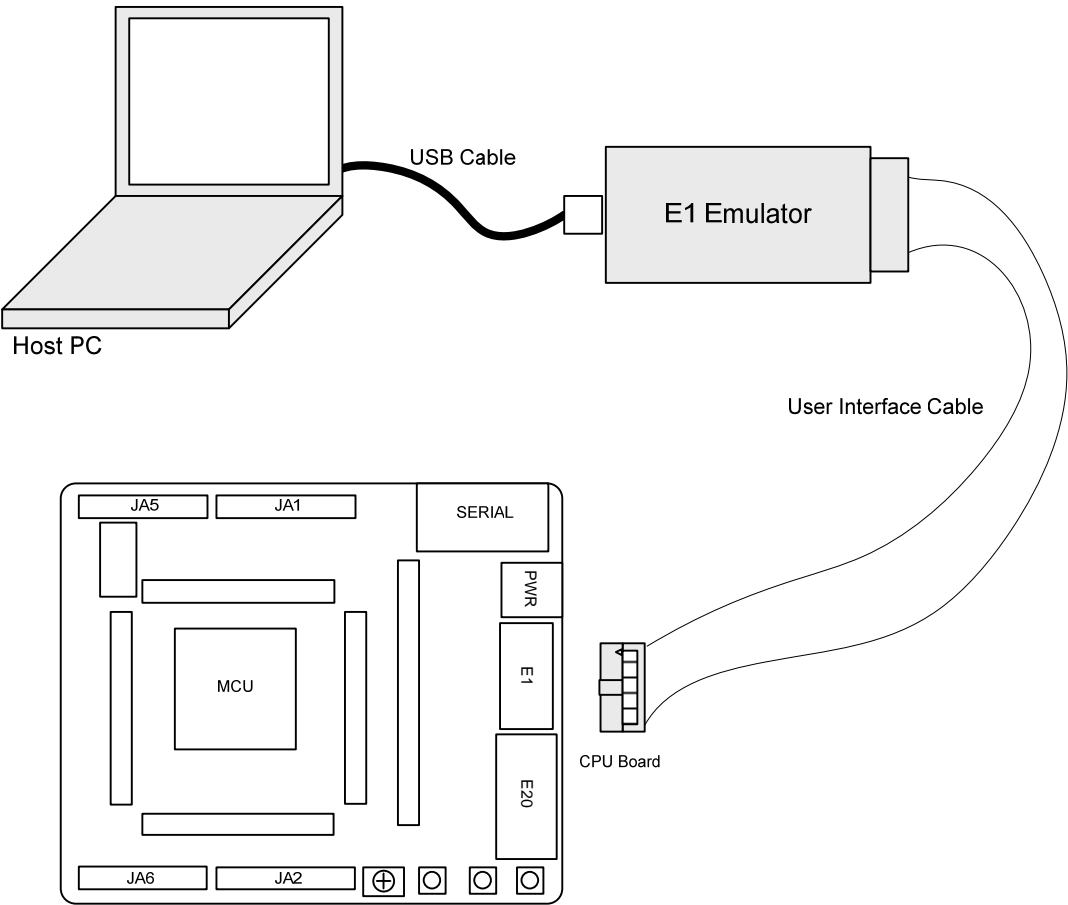

Figure 5-2: RSK Connections

Chapter 6. User Circuitry

6.1. Switches

There are four switches located on the CPU board. The function of each switch and its connection are shown in Table 6-1.

Switch	Function	Microcontroller
RES	When pressed, the RSK microcontroller is reset.	RESn, Pin 19
SW1/BOOT*	Connects to an IRQ input for user controls.	IRQ8-A, Pin 8 (P.00)
SW2*	Connects to an IRQ line for user controls.	IRQ9-A, Pin 7 (P.01)
SW3*	Connects to an IRQ Interrupt input for user controls.	IRQ3-B, Pin 44 (P.13)
	Connects to an ADTRG input for AD trigger controls.	

Table 6-1: Switch Functions

*Refer to schematic for detailed connectivity information.

6.2. LEDs

There are 4 user LEDs on the RSK board. The green 'POWER' LED lights when the board is powered; and the BOOT Led lights when the MCU is in Boot mode.

Table 6-2, below, shows the user LED pin references and their corresponding microcontroller port pin connections.

LED Reference (As shown on silkscreen)	Colour	Microcontroller Port Pin	Microcontroller Pin Number
LED0	Green	P.83	56
LED1	Orange	P.84	51
LED2	Red	P.33	26
LED3	Red	P.36	49

Table 6-2: LED Port

6.3. Potentiometer

A single turn potentiometer is connected to channel AN0 (pin 141) of the microcontroller. This may be used to vary the input analogue voltage value to this pin between AVCC and Ground.

Note: The potentiometer is fitted to offer an easy way of supplying a variable analogue input to the controller. It does not necessarily reflect the accuracy of the controllers ADC. Please see the device manual for details.

6.4. Serial port

The serial module of the RSK is connected to the MCU through the SCI1 port. Also connected to the serial module is the SCI0 & SCI4 port and the application header. The selection between these inputs is made through the option links (see section 6-6)

Net Name	Port	Device Pin
TMCIO_TxD0	SCI0	37
TMCIO_RxD0	SCI0	36
TxD1	SCI1	31
RxD1	SCI1	32
RS232TX	App. Head.	JA6, P5
RS232RX	App. Head.	JA6, P6
TDI_TxD4	SCI4	1
TCK_RxD4	SCI4	144

Table 6-3: Serial port pin details

6.5. Debug LCD Module

A debug LCD module is supplied to be connected to the connector LCD. Care should be taken to ensure the pins are inserted correctly into LCD. The debug LCD module uses a 4 bit interface to reduce the pin allocation. No contrast control is provided; this is set by a resistor on the supplied display module. The module supplied with the RSK only supports 5V operation.

Table 6-4 shows the pin allocation and signal names used on this connector.

LCD					
Pin	Circuit Net Name	Device Pin	Pin	Circuit Net Name	Device Pin
1	Ground	-	2	5V Only	-
3	No Connection	-	4	DLCDRS	18
5	R/W (Wired to Write only)	-	6	DLCDE + 100k pull down to ground (PC4)	17
7	No Connection	-	8	No connection	-
9	No Connection	-	10	No connection	-
11	DLCDD4 (PE0)	126	12	DLCDD5 (PE1)	125
13	DLCDD6 (PE2)	124	14	DLCDD7 (PE3)	123

Table 6-4 Debug LCD Module Connections

6.6. Option Links

Table 6-8 below describes the function of the option links contained on this RSK board. The default configuration is indicated by **BOLD** text.

Option Link Settings				
Reference	Function	Fitted	Alternative (Removed)	Related To
R81	WDT/TDO	Connects the TDO line to the MCU through the TDO_WDTOVFn pin	Disconnects the TDO line from the MCU through the TDO_WDTOVFn pin	R82
R82	WDT/TDO	Connects the WDTOVFn line to the MCU through the TDO_WDTOVFn pin	Disconnects the TDO line the MCU through the TDO_WDTOVFn pin.	R81
R83	CMT/SCI	Connects the TMO0 line to the MCU through the TMO0_SCK0 pin.	Disconnects the TMO0 line to the MCU through the TMO0_SCK0 pin.	R84
R84	CMT/SCI	Connects the SCK0 line to the MCU through the TMO0_SCK0 pin.	Disconnects the SCK0 line to the MCU through the TMO0_SCK0.	R83
R85	CMT/SCI	Connects the TMCIO to the MCU through the TMCIO_RxD0 pin.	Disconnects the TMCIO to the MCU through the TMCIO_RxD0.	R86
R86	CMT/SCI	Connects the RxD0 line to the MCU through the TMCIO_RxD0 pin.	Disconnects the RxD0 line to the MCU through the TMCIO_RxD0 pin.	R85
R87	CMT/SCI	Connects the TMRI0 line to the MCU through the TMRI0_TxD0 pin.	Disconnects the TMRI0 line to the MCU through the TMRI0_TxD0 pin.	R88
R88	CMT/SCI	Connects the TxD0 line to the MCU through the TMRI0_TxD0 pin.	Disconnects the TxD0 line to the MCU through the TMRI0_TxD0 pin.	R87
R89	SCI	Connects the SCL1 line to the MCU through the SCL1_SCK3 pin.	Disconnects the SCL1 line to the MCU through the SCL1_SCK3 pin.	R90
R90	SCI	Connects the SCK3 line to the MCU through the SCL1_SCK3 pin.	Disconnects the SCL1 line to the MCU through the SCL1_SCK3 pin.	R89
R91	IRQ	Connects SW3 to the SW3_ADTRG0n pin of the MCU.	Disconnects SW3 to the SW3_ADTRG0n pin of the MCU.	R92
R92	IRQ	Connects the ADTRG0n line to the MCU through the SW3_ADTRG0n pin.	Disconnects the ADTRG0n line to the MCU through the SW3_ADTRG0n pin.	R91
R93	BUS	Connects the WRn line to the MCU through the WRn_WR0n pin.	Disconnects the WRn line to the MCU through the WRn_WR0n pin.	R94
R94	BUS	Connects the WR0n line to the MCU through the WRn_WR0n pin.	Disconnects the WR0n line to the MCU through the WRn_WR0n pin.	R93
R95	AN	Connects the ADPOT to the MCU through the ADPOT_AN0 pin.	Disconnects the ADPOT to the MCU through the ADPOT_AN0 pin.	R96
R96	AN	Connects the AN0 line to the MCU through the ADPOT_AN0 pin.	Disconnects the AN0 line to the MCU through the ADPOT_AN0 pin.	R95

Table 6-8: Option link settings

Table 6-9 below describes the function of the jumper links contained on this RSK board. The default configuration is indicated by **BOLD** text.

Jumper Link Settings				
Reference	Function	Position 1	Position 2	Position 3
J5 (EXT_PWR)	External Power	Jumper across pins 1 and 2. Enable External power.	No jumper fitted, Disable External power, Power is supplied via E1.	
J7 (MDE)	Endian Mode	Jumper in the 'H' position. MCU operates in Big Endian Mode.	Jumper in the 'L' position. MCU operates in Little Endian Mode.	The jumper must be fitted, or undefined MCU operation may result.
J8* (MD0)	Mode 0	*This Jumper operates in conjunction with J9 to select the boot mode.		
J9* (MD1)	Mode 1	*This Jumper operates in conjunction with J8 to select the boot mode.		
J10 (EMLE)	EMLE	Jumper in the 'L' position. Emulator support is enabled.	Jumper in the 'H' position. Emulator support is disabled.	The jumper must be fitted, or undefined MCU operation may result.
J12** (TDI_TXD4)	Transmit Enable D4	Jumper across pins 1 and 2. Disable TDI through TxD4.	Jumper across pins 2 and 3. Enable TDI through TxD4.	Jumper across pins 1 and 3. Will cause undefined MCU operation – do not use this setting.
J13*** (TCK_RXD4)	Receive Enable D4	Jumper across pins 1 and 2. Disable TCK through RxD4.	Jumper across pins 2 and 3. Enable TCK through RxD4.	Jumper across pins 1 and 3. Will cause undefined MCU operation – do not use this setting.

Table 6-9: Jumper Link Settings

* MCU Operating Mode MD0(J8) MD1(J9)

Boot Mode 1 0

User Boot Mode 0 1

Single Chip Mode 1 1

The board is shipped with a 0 Ohm resistor (R108) fitted across J9 (pins 1 and 2) i.e. User Boot Mode (MD0=0,MD1=1).

** Transmit enable D4, the board is shipped with a 0Ohm resistor (R112) fitted across J12 (pins 2 and 3).

*** Receive enable D4, the board is shipped with a 0Ohm resistor (R113) fitted across J13 (pins 2 and 3).

6.7. Oscillator Sources

A crystal oscillator is fitted on the RSK and used to supply the main clock input to the Renesas microcontroller. Table 6-10 details the oscillators that are fitted and alternative footprints provided on this RSK:

Component	Function	Frequency
Crystal (X1)	CPU Clock	12.5 MHz

Table 6-10: Oscillators / Resonators

6.8. Reset Circuit

The CPU Board includes a simple latch circuit that links the mode selection and reset circuit. This provides an easy method for swapping the device between Boot Mode and User mode. This circuit is not required on customer's boards as it is intended for providing easy evaluation of the operating modes of the device on the RSK. Please refer to the hardware manual for more information on the requirements of the reset circuit.

The Reset circuit operates by latching the state of the boot switch on pressing the reset button. This control is subsequently used to modify the mode pin states as required.

The mode pins should change state only while the reset signal is active to avoid possible device damage.

The reset is held in the active state for a fixed period by a pair of resistors and a capacitor. Please check the reset requirements carefully to ensure the reset circuit on the user's board meets all the reset timing requirements.

Chapter 7. Modes

This RSK supports Boot mode, User Boot mode, and Single Chip Mode.

Details of programming the FLASH memory is described in the RX610 Group Hardware Manual.

MD1	MD0	Mode Name
0	1	Boot Mode
1	0	User Boot Mode
1	1	Single Chip Mode

Table 7-1: MCU Operating Modes Table

Chapter 8. Programming Methods

The board is intended for use with HEW and the supplied E1 debugger. Refer to RX610 Group Hardware Manual for details of programming the microcontroller without using these tools.

Chapter 9. Headers

9.1. Application Headers

Table 9-1 to 9-5 show the microcontroller application headers and their corresponding microcontroller connections.

Standard APP Header, JA1					
Pin	Circuit Net Name	MCU Pin	Pin	Circuit Net Name	MCU Pin
1	5V	-	2	0V(5V)	
3	3V3	-	4	0V(3V3)	
5	AVcc	-	6	AVss	-
7	AVref	-	8	ADTRG	-
9	AD0	141	10	AD1	139
11	AD2	138	12	AD3	137
13	DAC0	4	14	DAC1	3
15	IO_0	90	16	IO_1	89
17	IO_2	88	18	IO_3	87
19	IO_4	86	20	IO_5	68
21	IO_6	67	22	IO_7	66
23	IRQ3	9	24	IIC_EX	NC
25	IIC_SDA	-	26	IIC_SCL	-

Table 9-1: Standard APP Header, JA1

Standard APP Header, JA2					
Pin	Circuit Net Name	MCU Pin	Pin	Circuit Net Name	MCU Pin
1	RESET	19	2	EXTAL	-
3	NMI	24	4	Vss1	-
5	WDT_OVF	11	6	SClATX	31
7	IRQ0/KWUP	47	8	SClARX	32
9	IRQ1	46	10	SClACK	30
11	MO_up/down	NC	12	CTSRTS	NC
13	MO_Up	NC	14	MO_Un	NC
15	MO_Vp	NC	16	MO_Vn	NC
17	MO_Wp	NC	18	MO_Wn	NC
19	Timer_Out	33	20	Timer_Out	35
21	Timer_In	34	22	Timer_in	36
23	IRQ2	45	24	TRISTn	NC
25	Spare	NC	26	Spare	NC

Table 9-2: Standard APP Header, JA2

BUS APP Header, JA3					
Pin	Circuit Net Name	MCU Pin	Pin	Circuit Net Name	MCU Pin
1	A0	101	A1	A1	100
3	A2	99	4	A3	98
97	A4	97	6	A5	96
7	A6	95	8	A7	94
9	A8	92	10	A9	85
11	A10	84	12	A11	83
13	A12	82	14	A13	81
15	A14	80	16	A15	79
17	D0	122	18	D1	121
19	D2	120	20	D3	119
21	D4	113	22	D5	112
23	D6	111	24	D7	110
25	RD	63	26	WR	64
27	CSa	118	28	CSb	117
29	D8	109	30	D9	108
31	D10	107	32	D11	106
33	D12	105	34	D13	104
35	D14	103	36	D15	102
37	A16	78	38	A17	77
39	A18	75	40	A19	73
41	A20	72	42	A21	71
43	A22	70	44	SDCLK	62
45	CSc	116	46	ALE	NC
Q	HWRn	64	48	LWRn	65
49	CAS	NC	50	RAS	NC

Table 9-3: BUS APP Header, JA3

Option APP Header, JA5					
Pin	Circuit Net Name	MCU Pin	Pin	Circuit Net Name	MCU Pin
1	AD4	136	2	AD5	135
3	AD6	134	4	AD7	133
5	CAN1TX	NC	6	CAN1RX	NC
7	CAN2TX	NC	8	CAN2RX	NC
9	AD8	131	10	AD9	129
11	AD10	128	12	AD11	127
13	TIOCoA	29	14	TIOCoB	28
15	TIOCoC	27	16	M2_TRISTn	NC
17	TCLKC	50	18	TCLKD	48
19	M2_Up	NC	20	M2_Un	NC
21	M2_Vp	NC	22	M2_Vn	NC
23	M2_W	NC	24	M2_Wn	NC

Table 9-4: Option APP Header, JA5

Option APP Header, JA6					
Pin	Circuit Net Name	MCU Pin	Pin	Circuit Net Name	MCU Pin
1	DREQ	NC	2	DACK	NC
3	TEND	NC	4	STBYn	NC
5	RS32TX	-	6	RS232RX	-
7	SClBbRX	36	8	SClBbTX	37
9	SClCtTX	38	10	SClBbCK	35
11	SClCtCK	42	12	SClCtRX	40
13	Reserved	NC	14	Reserved	NC
15	Reserved	NC	16	Reserved	NC
17	Reserved	NC	18	Reserved	NC
19	Reserved	NC	20	Reserved	NC
21	Reserved	NC	22	Reserved	NC
23	Reserved	NC	24	Reserved	NC
25	Unregulated_Vcc	-	26	Vss	-

Table 9-5: Option APP Header, JA6

9.2. Microcontroller Ring Headers

Table 9-1 to 9-9 show the microcontroller ring headers and their corresponding microcontroller connections.

Microcontroller Pin Header, J1					
Pin	Circuit Net Name	MCU Pin	Pin	Circuit Net Name	MCU Pin
1	TDI_TxD4	144	2	TMS	2
3	DA1	3	4	DA0	4
5	AVSS	-	6	TRSTn	6
7	SW2	7	8	SW1	8
9	IRQ15n-A	9	10	EMLE	10
11	TDO_WDTOVFn	11	12	Ground	-
13	MDE	13	14	No Connection	NC
15	MD1	15	16	MD0	16
17	DLCDE	17	18	DLCDRS	18
19	RESn	19	20	CON_XTAL	-
21	Ground	-	22	CON_EXTAL	-
23	UC_VCC	-	24	NMIIn	24
25	PIN25	25	26	LED2	26
27	TIOCC0	27	28	TIOCB0	28
29	TIOCA0	29	30	SCK1	30
31	TxD1	31	32	RxD1	32
33	TIOCA4	33	34	TIOCC3	34
35	TMO0_SCK0	35	36	TMCIO_RxD0	36

Table 9-6: Microcontroller Pin Header, J1

Microcontroller Pin Header, J2					
Pin	Circuit Net Name	MCU Pin	Pin	Circuit Net Name	MCU Pin
1	TMRIO_TxD0	37	2	TxD3	38
3	No Connection	NC	4	RxD3	40
5	No Connection	NC	6	SCL1_SCK3	42
7	SDA1	43	8	SW3_ADTRG0n	44
9	IRQ2n-B	45	10	IRQ1n-B	46
11	IRQ0n-B	47	12	TCLKD-A	48
13	LED3	49	14	TCLKC-A	50
15	LED1	51	16	TRDATA3	52
17	TRDATA2	53	18	TRDATA1	54
19	TRDATA0	55	20	LED0	56
21	Ground	-	22	TRCLK	58
23	UC_VCC	-	24	TRSYNCn	60
25	PIN61	61	26	PIN62_BCLK	62
27	RDn	63	28	WR1n	64
29	WRn-WR0N	65	30	IO7	66
31	IO6	67	32	IO5	68
33	PIN69	69	34	A22	70
35	A21	71	36	A20	72

Table 9-7: Microcontroller Pin Header, J2

Microcontroller Pin Header, J3					
Pin	Circuit Net Name	MCU Pin	Pin	Circuit Net Name	MCU Pin
1	A19	73	2	UC_VCC	-
3	A18	75	4	Ground	-
5	A17	77	6	A16	78
7	A15	79	8	A14	80
9	A13	81	10	A12	82
11	A11	83	12	A10	84
13	A9	85	14	IO4	86
15	IO3	87	16	IO2	88
17	IO1	89	18	IO0	90
19	UC_VCC	-	20	A8	92
21	Ground	-	22	A7	94
23	A6	95	24	A5	96
25	A4	97	26	A3	98
27	A2	99	28	A1	100
29	A0	101	30	D15	102
31	D14	103	32	D13	104
33	D12	105	34	D11	106
35	D10	107	36	D9	108

Table 9-8: Microcontroller Pin Header, J3

Microcontroller Pin Header, J4					
Pin	Circuit Net Name	MCU Pin	Pin	Circuit Net Name	MCU Pin
1	D8	109	2	D7	110
3	D6	111	4	D5	112
5	D4	113	6	PIN114	114
7	PIN115	115	8	PIN116_CS2n-A	116
9	PIN 117_CS1n	117	10	PIN118_CS0n	118
11	D3	119	12	D2	120
13	D1	121	14	D0	122
15	DLCDD7	123	16	DLCDD6	124
17	DLCDD5	125	18	DLCDD4	126
19	AN11	127	20	AN10	128
21	AN9	129	22	Ground	-
23	AN8	131	24	UC_VCC	-
25	AN7	133	26	AN6	134
27	AN5	135	28	AN4	136
29	AN3	137	30	AN2	138
31	AN1	139	32	AVSS	-
33	ADPOT_AN0	141	34	VREF	-
35	AVCC	-	36	TCK_RxD4	-

Table 9-9: Microcontroller Pin Header, J4

Chapter 10. Code Development

10.1. Overview

Note: For all code debugging using Renesas software tools, the RSK board must be connected to a PC USB port via an E1. An E1 pod is supplied with the RSK product.

10.2. Compiler Restrictions

The compiler supplied with this RSK is fully functional for a period of 60 days from first use. After the first 60 days of use have expired, the compiler will default to a maximum of 64k code and data. To use the compiler with programs greater than this size you need to purchase the full tools from your distributor.

Warning: The protection software for the compiler will detect changes to the system clock. Changes to the system clock back in time may cause the trial period to expire prematurely.

10.3. Mode Support

HEW connects to the Microcontroller and programs it via the E1. Mode support is handled transparently to the user.

10.4. Breakpoint Support

HEW supports breakpoints on the user code, both in RAM and ROM.

Double clicking in the breakpoint column in the code sets the breakpoint. Breakpoints will remain unless they are double clicked to remove them.

10.5. Memory Map

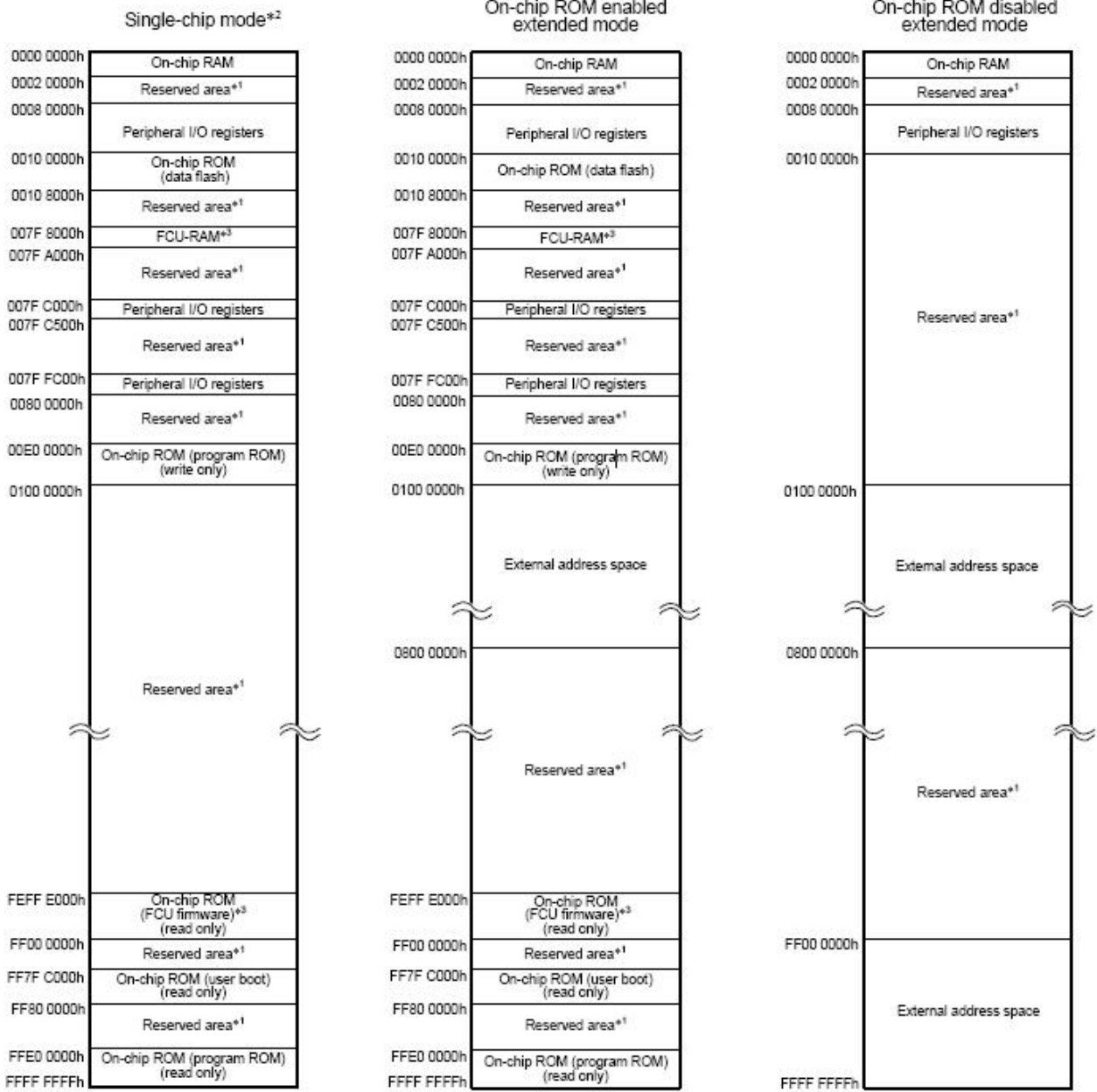

- Notes:
1. A reserved area should not be accessed.
 2. The address space in boot mode and user boot mode is the same as the address space in single-chip mode.
 3. For details on the FCU, see section 26, ROM (Flash Memory for Code Storage) and section 27, Data Flash (Flash Memory for Data Storage).

Figure 10-1: Memory Map

10.6. Component Placement

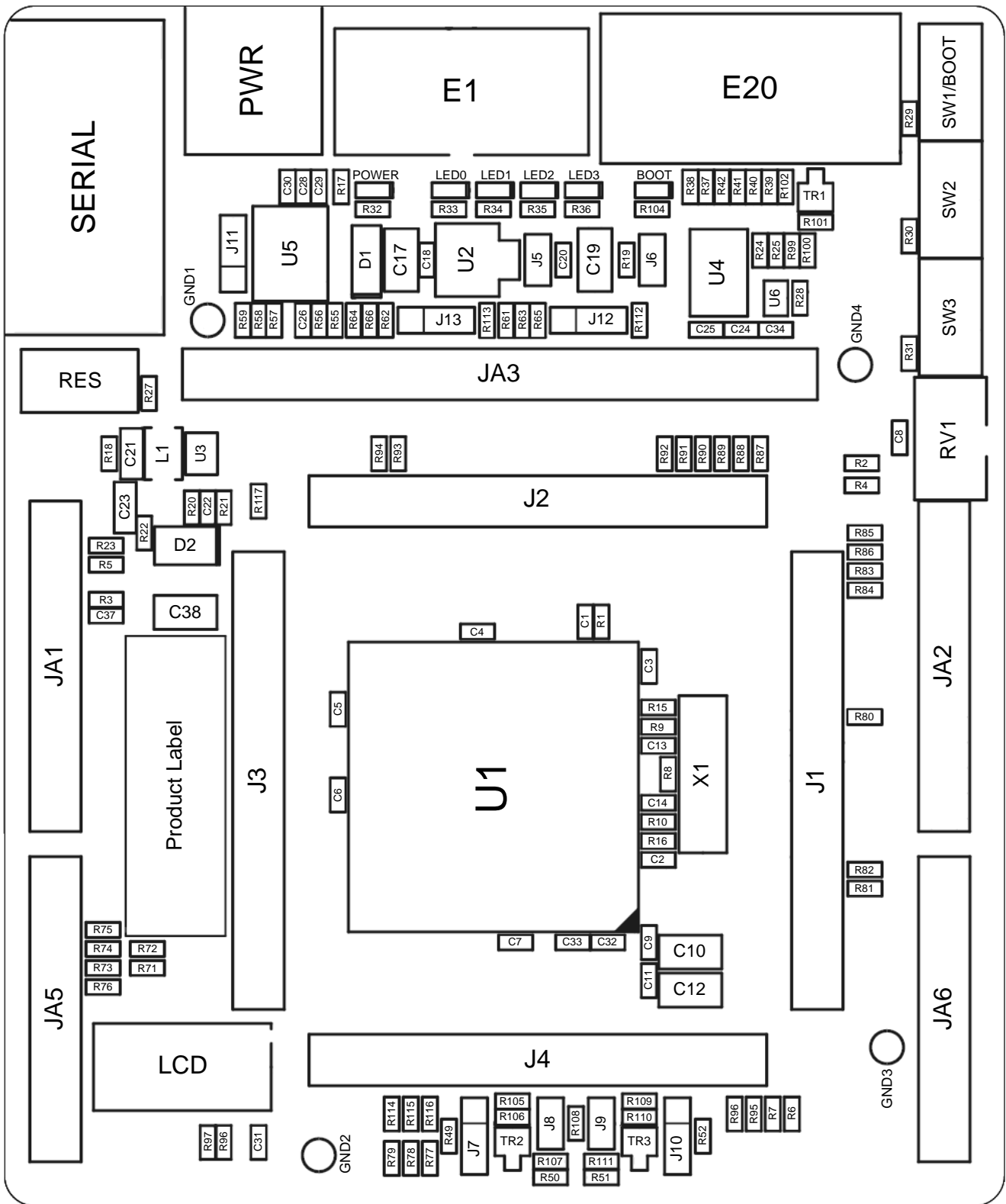

Figure 11-1: Component Placement – Front view

Chapter 11. Additional Information

For details on how to use High-performance Embedded Workshop (HEW, refer to the HEW manual available on the CD or from the web site.

For information about the RX610 series microcontrollers refer to the RX610 Group hardware manual.

For information about the RX610 assembly language, refer to the RX600 Series Software Manual.

Online technical support and information is available at: http://www.renesas.com/renesas_starter_kits

Technical Contact Details

America: techsupport.rta@renesas.com

Europe: tools.support.eu@renesas.com

Japan: csc@renesas.com

General information on Renesas Microcontrollers can be found on the Renesas website at: <http://www.renesas.com/>

Renesas Starter Kit for RX610

User's Manual

Publication Date Rev.1.02 24.Mar.2010

Published by: **Renesas Technology Europe Ltd.**
Duke's Meadow, Millboard Road, Bourne End
Buckinghamshire SL8 5FH, United Kingdom

©2009 Renesas Technology Europe and Renesas Solutions Corp., All Rights Reserved.

Renesas Starter Kit for RX610 User's Manual



Renesas Electronics Corporation

1753, Shimonumabe, Nakahara-ku, Kawasaki-shi, Kanagawa 211-8668 Japan

REJ10J1917-0102