

REJ10J2125-0100

A horizontal decorative bar consisting of a solid blue section on the left and a grey section with horizontal lines on the right.

Renesas Starter Kit for R8C/35C User's Manual

RENESAS MCU
R8C Family R8C/3x Series

Rev.1.00
Revision date: 01.Apr.2010

Renesas Electronics Europe Ltd.
www.renesas.com

Disclaimer

By using this Renesas Starter Kit (RSK), the user accepts the following terms. The RSK is not guaranteed to be error free, and the entire risk as to the results and performance of the RSK is assumed by the User. The RSK is provided by Renesas on an "as is" basis without warranty of any kind whether express or implied, including but not limited to the implied warranties of satisfactory quality, fitness for a particular purpose, title and non-infringement of intellectual property rights with regard to the RSK. Renesas expressly disclaims all such warranties. Renesas or its affiliates shall in no event be liable for any loss of profit, loss of data, loss of contract, loss of business, damage to reputation or goodwill, any economic loss, any reprogramming or recall costs (whether the foregoing losses are direct or indirect) nor shall Renesas or its affiliates be liable for any other direct or indirect special, incidental or consequential damages arising out of or in relation to the use of this RSK, even if Renesas or its affiliates have been advised of the possibility of such damages.

Precautions

This Renesas Starter Kit is only intended for use in a laboratory environment under ambient temperature and humidity conditions. A safe separation distance should be used between this and sensitive equipment. Its use outside the laboratory, classroom, study area or similar such area invalidates conformity with the protection requirements of the Electromagnetic Compatibility Directive and could lead to prosecution.

The product generates, uses, and can radiate radio frequency energy and may cause harmful interference to radio communications. However, there is no guarantee that interference will not occur in a particular installation. If this equipment causes harmful interference to radio or television reception, which can be determined by turning the equipment off or on, you are encouraged to try to correct the interference by one or more of the following measures;

- Ensure attached cables do not lie across the equipment
- reorient the receiving antenna
- increase the distance between the equipment and the receiver
- connect the equipment into an outlet on a circuit different from that which the receiver is connected
- power down the equipment when not in use
- consult the dealer or an experienced radio/TV technician for help NOTE: It is recommended that wherever possible shielded interface cables are used.

The product is potentially susceptible to certain EMC phenomena. To mitigate against them it is recommended that the following measures be undertaken;

- The user is advised that mobile phones should not be used within 10m of the product when in use.
- The user is advised to take ESD precautions when handling the equipment.

The Renesas Starter Kit does not represent an ideal reference design for an end product and does not fulfil the regulatory standards for an end product.

Table of Contents

Chapter 1. Preface	1
Chapter 2. Purpose	2
Chapter 3. Power Supply	3
3.1. Requirements	3
3.2. Power – Up Behaviour	3
Chapter 4. Board Layout	4
4.1. Component Layout	4
4.2. Board Dimensions	5
Chapter 5. Block Diagram	6
Chapter 6. User Circuitry	8
6.1. Switches	8
6.2. LEDs	8
6.3. Potentiometer	8
6.4. Serial port	9
6.5. Hardware LIN	9
6.6. Debug LCD Module	10
6.7. Option Links	10
6.8. Oscillator Sources	15
6.9. Reset Circuit	15
Chapter 7. Modes	16
7.1. Boot mode	16
7.2. Single chip mode	16
Chapter 8. Programming Methods	17
Chapter 9. Headers	18
9.1. Microcontroller Headers	18
9.2. Application Headers	20
Chapter 10. Code Development	22
10.1. Overview	22
10.2. Compiler Restrictions	22
10.3. Mode Support	22
10.4. Breakpoint Support	22
10.5. Memory Map	23
Chapter 11. Component Placement	24
Chapter 12. Additional Information	25

Chapter 1. Preface

Cautions

This document may be, wholly or partially, subject to change without notice.

All rights reserved. Duplication of this document, either in whole or part is prohibited without the written permission of Renesas Solutions Corporation.

Trademarks

All brand or product names used in this manual are trademarks or registered trademarks of their respective companies or organisations.

Copyright

© 2010 Renesas Electronics Europe Ltd. All rights reserved.

© 2010 Renesas Electronics Corporation. All rights reserved.

© 2010 Renesas Solutions Corporation. All rights reserved.

Website: <http://www.eu.renesas.com/> (Europe)

<http://www.renesas.com/> (Global)

Glossary

ADC	Analog Digital Converter	LIN	Local Interconnect Network
CPU	Central Processing Unit	LSI	Large Scale Integration
DAC	Digital Analog Converter	MCU	Micro Controller Unit
E8a	E8a On-chip debugger module	PC	Personal Computer
EMC	Electromagnetic Compatibility	RAM	Random Access memory
HEW	High-Performance Embedded Workshop	ROM	Read Only Memory
IRQ	Interrupt Request	RSK	Renesas Starter Kit
LCD	Liquid Crystal Display	UART	Universal Asynchronous Receiver/Transmitter
LED	Light Emitting Diode	USB	Universal Serial Bus

Chapter 2. Purpose

This Renesas Starter Kit is an evaluation tool for Renesas microcontrollers.

Features include:

- Renesas Microcontroller Programming.
- User Code Debugging.
- User Circuitry such as Switches, LEDs and potentiometer.
- User or Example Application.
- Sample peripheral device initialisation code.

The Renesas Starter Kit board contains all the circuitry required for microcontroller operation.

NOTE: This manual describes the technical details of the Renesas Starter Kit for R8C/35C hardware. The Quick Start Guide and Tutorial Manual provide details of the software installation and debugging environment.

Chapter 3. Power Supply

3.1. Requirements

This Renesas Starter Kit operates from a 5V power supply.

A diode provides reverse polarity protection only if a current limiting power supply is used.

This Renesas Starter Kit board is supplied with an E8a debugger. This product is able to power the Renesas Starter Kit board with up to 300mA. When the Renesas Starter Kit is connected to another system then that system should supply power to the Renesas Starter Kit.

All Renesas Starter Kit boards have an optional centre positive supply connector using a 2.1mm barrel power jack.

Warning

The Renesas Starter Kit is neither under nor over voltage protected. Use a centre positive supply for this board.

3.2. Power – Up Behaviour

When the Renesas Starter Kit is purchased the Renesas Starter Kit board has the 'Release' or stand alone code from the example tutorial code pre-programmed into the Renesas microcontroller. On powering up the board the user LEDs will start to flash. After 200 flashes, or after pressing a switch the LEDs will flash at a rate controlled by the potentiometer.

Chapter 4. Board Layout

4.1. Component Layout

The following diagram shows the top layer component layout of the board.

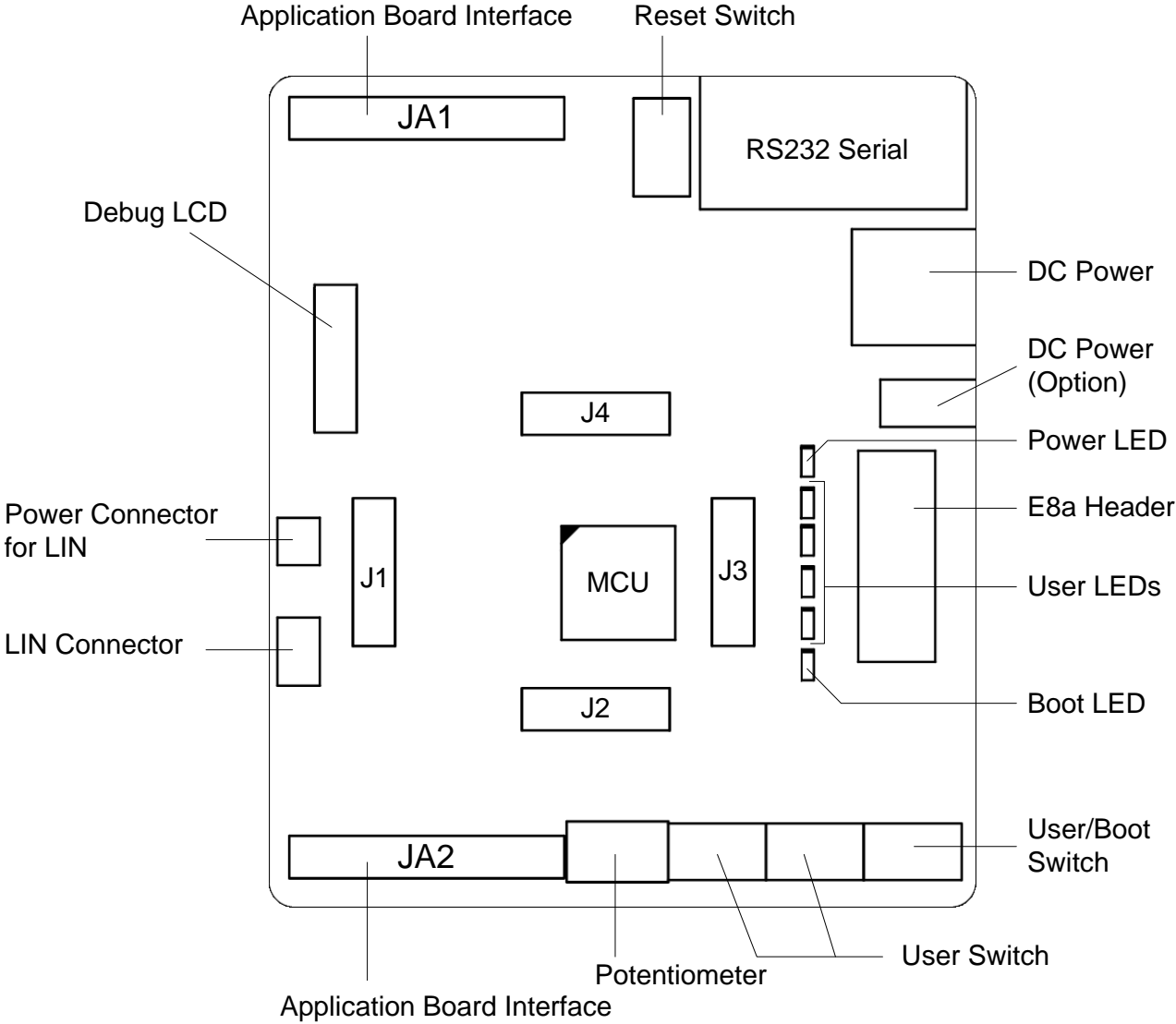

J1 to J4: Microcontroller Pin Headers

Figure 4-1: Board Layout

4.2. Board Dimensions

The following diagram gives the board dimensions and connector positions. All through hole connectors are on a common 0.1" grid for easy interfacing.

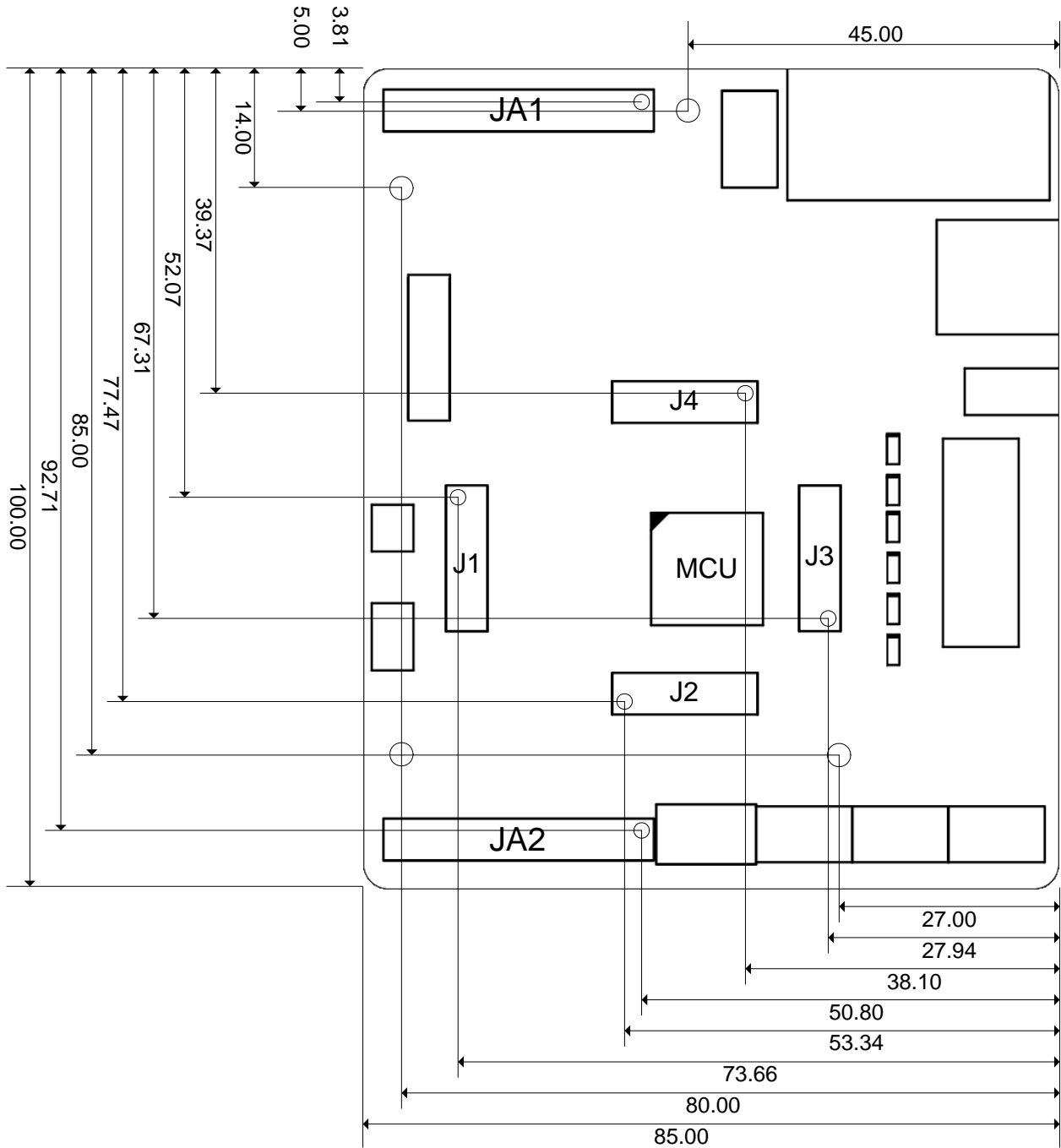

Figure 4-2 : Board Dimensions

Chapter 5. Block Diagram

Figure 5-1 is representative of the CPU board components and their connectivity.

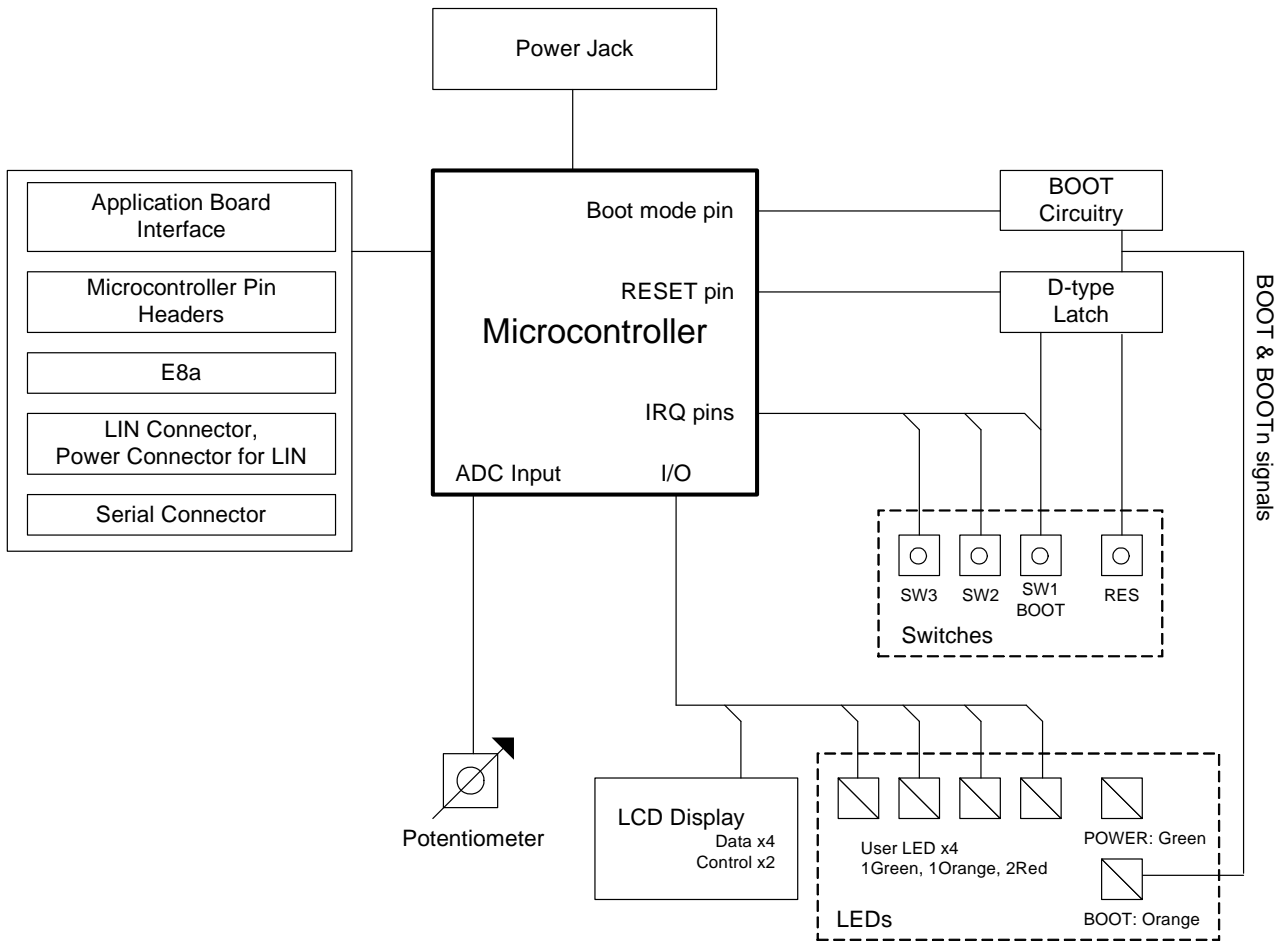

Figure 5-1: Block Diagram

Figure 5-2 is representative of the connections required to the Renesas Starter Kit.

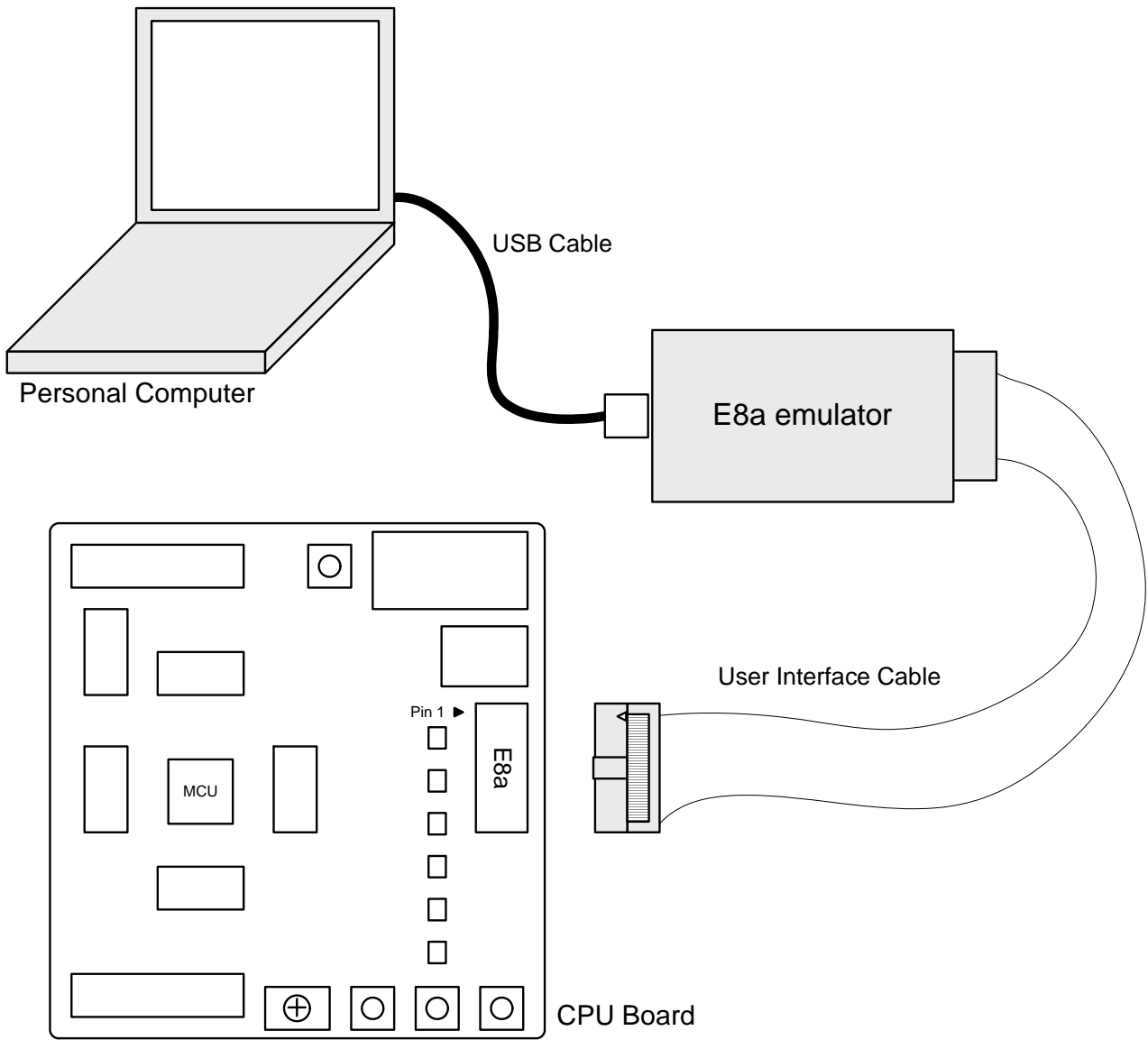

Figure 5-2 : Renesas Starter Kit Connections

Chapter 6. User Circuitry

6.1. Switches

There are four switches located on the board. The function of each switch and its connection are shown in Table 6-1.

Switch	Function	Microcontroller
RES	When pressed, the board microcontroller is reset.	RESETn, Pin8
SW1/BOOT*	Connects to an IRQ input for user controls. The switch is also used in conjunction with the RES switch to place the device in BOOT mode when not using the E8a debugger.	INT1n, Pin31 (Port 1, pin 7)
SW2*	Connects to an IRQ Interrupt input for user controls.	INT2n, Pin28 (Port 6, pin 6)
SW3*	Connects to an IRQ Interrupt input for user controls.	ADTRGn_INT0n, Pin30 (Port 4, pin 5)
	Connects to an ADTRG input for AD trigger controls.	

Table 6-1: Switch Functions

*Refer to schematic for detailed connectivity information.

6.2. LEDs

There are six LEDs on the CPU board. The green 'POWER' LED lights when the board is powered. The orange 'BOOT' LED indicates the device is in BOOT mode when lit. The four user LEDs are connected to an IO port and will light when their corresponding port pin is set low.

Table 6-2, below, shows the LED pin references and their corresponding microcontroller port pin connections.

LED Reference (As shown on silkscreen)	Colour	Microcontroller Port Pin function	Microcontroller Pin Number
LED0	Green	Port 3.1	26
LED1	Orange	Port 3.3	16
LED2	Red	Port 3.4	15
LED3	Red	Port 3.6	25

Table 6-2: LED Port

6.3. Potentiometer

A single turn potentiometer is connected to AN8 (Port1.0) of the microcontroller. This may be used to vary the input analog voltage value to this pin between VREF and Ground.

The potentiometer is fitted to offer an easy way of supplying a variable analog input to the controller. It does not necessarily reflect the accuracy of the controllers ADC. Please see the device manual for details.

6.4. Serial port

Serial port UART0 and serial port UART1 are connected to the RS232 transceiver. These serial ports can optionally be connected to the RS232 transceiver as well by fitting option resistors. The connections are listed in the Table 6-3.

Description	Circuit Net Name	Function	Fit for RS232	Remove for RS232
UART0 *1	LINTXD	Secondary Serial Port	R48	R46, R47, R65, R66
UART0 *1	LINRXD	Secondary Serial Port	R49	
UART1 *2, *3	TXD1	Default Serial Port	R46, R70	R48, R49, R71, R73
UART1 *2, *3	RXD1	Default Serial Port	R47, R72	

Table 6-3: Serial Port settings

*1: The UART0 port is shared with the LIN module.

*2: The UART1 port is shared with the I/O pin on JA1 application header.

*3: The UART1 port is also available on JA2 application header.

6.5. Hardware LIN

Hardware LIN could be connected to TXD0, RXD0 and CLK0 pins. The connections to be fitted are listed in the Table 6-4.

Description	Function	Circuit Net Name	Device Pin	Fit for Hardware LIN	Remove for Hardware LIN
LIN	TXD	LINTXD	34	R66	R48
LIN	RXD	LINRXD	33	R65	R49
LIN	NSLP	LINNSLP	32	R64	-

Table 6-4: Hardware LIN settings

Hardware LIN can be selected as Master or Slave. Resistor selections are listed in the Table 6-5.

Master and Slave Selection		
Resistor	Master	Slave
R67	Fit	Remove
R68	Fit	Remove

Table 6-5: LIN Master and Slave Selection

6.6. Debug LCD Module

A LCD module is supplied to be connected to the connector LCD. This should be fitted so that the LCD module lies over J4. Care should be taken to ensure the pins are inserted correctly into LCD. The LCD module uses a 4 bit interface to reduce the pin allocation. No contrast control is provided; this is set by a resistor on the supplied display module. The module supplied with the Renesas Starter Kit only supports 5V operation.

Table 6-6 shows the pin allocation and signal names used on this connector.

LCD					
Pin	Circuit Net Name	Device Pin	Pin	Circuit Net Name	Device Pin
1	Ground	-	2	Board_VCC (5V Only)	-
3	No Connection	-	4	DLCDRS (Port 6.5)	29
5	R/W (Wired to Write only)	-	6	DLCDE (Port 6.4)	47
7	No Connection	-	8	No Connection	-
9	No Connection	-	10	No Connection	-
11	DLCDD4 (Port 6.0)	51	12	DLCDD5 (Port 6.1)	50
13	DLCDD6 (Port 6.2)	49	14	DLCDD7 (Port 6.3)	48

Table 6-6: Debug LCD Module Connections

6.7. Option Links

Table 6-7 below describes the function of the option links associated with Power configuration. The default configuration is indicated by **BOLD & Red** text.

Option Link Settings				
Reference	Function	Fitted	Alternative (Removed)	Related To
R21	Power Supply	Enables external 5V power supply from PWR1 connector	Disables power supply from PWR1 connector.	-
R23	Power Supply	Must be fitted if supplying voltage from CON_5V	Disconnects power supply from CON_5V	-
R24	Power Supply	Must be fitted if supplying voltage from CON_3V3	Disconnects power supply from CON_3V3	-
R25	MCU Power Supply	Supply to MCU	Disables power supply for MCU. Current can measured across J6.	-

Table 6-7: Power Configuration Links

Table 6-8 below describes the function of the option links associated with Clock configuration. The default configuration is indicated by **BOLD & Red** text.

Option Link Settings				
Reference	Function	Fitted	Alternative (Removed)	Related To
R1	20MHz Main Clock Oscillator	Parallel resistor for on-board main clock X1.	Not fitted	-
R2	20MHz Main Clock Oscillator	X1 is used for XIN	External clock source is used for XIN	R3, R4, R5
R3	20MHz Main Clock Oscillator	X1 is used for XOUT	External clock source is used for XOUT	R2, R4, R5
R4	20MHz Main Clock Oscillator	Routes XIN CPU pin to J1 header	XIN CPU pin and J1 header are not connected	R2, R3, R5
R5	20MHz Main Clock Oscillator	Routes XOUT CPU pin to J1 and JA2 headers (External clock source is used for XOUT)	XOUT CPU pin and J1 and JA2 headers are not connected	R2, R3, R4
R6	32.768kHz Sub Clock Oscillator	Parallel resistor for on-board sub clock X2.	Not fitted	-
R7	32.768kHz Sub Clock Oscillator	X2 is used for XCIN	X2 is disconnected for XCIN	R8, R9, R10
R8	32.768kHz Sub Clock Oscillator	X2 is used for XCOUT	X2 is disconnected for XCOUT	R7, R9, R10
R9	32.768kHz Sub Clock Oscillator	Routes XCIN CPU pin to J1 header	XCIN CPU pin and J1 header are not connected	R7, R8, R10
R10	32.768kHz Sub Clock Oscillator	Routes XCOUT CPU pin to J1 header	XCOUT CPU pin and J1 header are not connected	R7, R8, R9

Table 6-8: Clock Configuration Links

Table 6-9 below describes the function of the option links associated with Analog configuration. The default configuration is indicated by **BOLD & Red** text.

Option Link Settings				
Reference	Function	Fitted	Alternative (Removed)	Related To
R11	Reference Voltage Source	Reference voltage source is taken from the external connector CON_VREF to ADPOT	Reference voltage source is set to UC_VCC	R12, R13
R12	Reference Voltage Source	Reference voltage source is set to UC_VCC	Reference voltage source is taken from the external connector CON_VREF to ADPOT	R11, R13
R13	Reference Voltage Source	Supply to MCU	Disconnected	R11, R12
R14	ADPOT	Connects on-board potentiometer ADPOT to MCU Port1.0 (MCU Pin#38)	Disconnected	-

Table 6-9: Analog Configuration Links

Table 6-10 below describes the function of the option links associated with application board interface configuration. The default configuration is indicated by **BOLD & Red** text.

Option Link Settings				
Reference	Function	Fitted	Alternative (Removed)	Related To
R56	Application Board Interface	Connects DA0 to MCU Port0.6 (MCU Pin#40)	Disconnected	R57
R57	Application Board Interface	Connects IO6 to MCU Port0.6 (MCU Pin#40)	Disconnected	R56
R58	Application Board Interface	Connects DA1 to MCU Port0.7 (MCU Pin#39)	Disconnected	R59
R59	Application Board Interface	Connects IO7 to MCU Port0.7 (MCU Pin#39)	Disconnected	R58
R60	Application Board Interface	Connects ADTRGn to MCU Port4.5(MCU Pin#30)	Disconnected	R61
R61	Application Board Interface	Connects INT0n to MCU Port4.5(MCU Pin#30)	Disconnected	R60
R70	Application Board Interface	Connects TXD1 to MCU Port0.1 (MCU Pin#45)	Disconnected	R71
R71	Application Board Interface	Connects IO1 to MCU Port0.1 (MCU Pin#45)	Disconnected	R70
R72	Application Board Interface	Connects RXD1 to MCU Port0.2 (MCU Pin#44)	Disconnected	R73
R73	Application Board Interface	Connects IO2 to MCU Port0.2 (MCU Pin#44)	Disconnected	R72
R74	Application Board Interface	Connects CLK1 to MCU Port0.3 (MCU Pin#43)	Disconnected	R75
R75	Application Board Interface	Connects IO3 to MCU Port0.3 (MCU Pin#43)	Disconnected	R74

Table 6-10: Application Board Interface Links

Table 6-11 below describes the function of the option links associated with other options. The default configuration is indicated by **BOLD & Red** text.

Option Link Settings				
Reference	Function	Fitted	Alternative (Removed)	Related To
R30	SW1	Connects SW1 to MCU Port1.7 (MCU Pin#31)	Disconnected	-
R31	SW2	Connects SW2 to MCU Port6.6 (MCU Pin#28)	Disconnected	-
R32	SW3	Connects SW3 to MCU Port4.5 (MCU Pin#30)	Disconnected	-
R50	E8a	Enables E8a Connection	Do not remove resistor R50	-

Table 6-11: Other Option Links

6.8.Oscillator Sources

Crystal oscillators are fitted on the board and used to supply the main/sub clock input to the Renesas microcontroller.

Table 6-12 details the oscillators that are fitted and alternative footprints provided on this board:

Component		
Main clock (X1)	Fitted	20 MHz (HC/49U package)
Sub clock (X2)	Fitted	32.768 kHz (90SMX package)

Table 6-12: Oscillator

6.9.Reset Circuit

The CPU Board includes a simple latch circuit that links the mode selection and reset circuit. This provides an easy method for swapping the device between Boot mode and Single chip mode. This circuit is not required on customers' boards as it is intended for providing easy evaluation of the operating modes of the device on the Renesas Starter Kit. Please refer to the hardware manual for more information on the requirements of the reset circuit.

The Reset circuit operates by latching the state of the boot switch on pressing the reset button. This control is subsequently used to modify the MODE pin states as required.

The MODE pin should change state only while the reset signal is active to avoid possible device damage.

The reset is held in the active state for a fixed period by a pair of resistors and a capacitor. Please check the reset requirements carefully to ensure the reset circuit on the customers' board meets all the reset timing requirements.

Chapter 7. Modes

The Renesas Starter Kit supports Boot mode and Single chip mode.

Details of programming the FLASH memory is described in the R8C/35C Group Hardware Manual.

7.1. Boot mode

The Boot mode settings for this Renesas Starter Kit are shown in Table 7-1 below:

MODE	LSI State after Reset End
Low	Boot Mode

Table 7-1: Boot Mode pin settings

The software supplied with this Renesas Starter Kit supports Boot mode using an E8a and High-performance Embedded Workshop only. However, hardware exists to enter boot mode manually, do not connect the E8a in this case. Press and hold the SW1/BOOT. The MODE pin is held in its boot state while reset is pressed and released. Release the boot button. The BOOT LED will be illuminated to indicate that the microcontroller is in Boot mode.

When neither the E8a is connected nor the board is placed in Boot mode as above, the MODE pin is pulled high by a 4.7k resistor.

When an E8a is used the MODE pin is controlled by the E8a.

7.2. Single chip mode

Because the MODE pin is pulled high, this Renesas Starter Kit will always boot in Single chip mode when the E8a is not connected and the boot switch is not depressed. Refer to R8C/35C Group Hardware Manual for details of Single chip mode.

MODE	LSI State after Reset End
High	Single chip Mode

Table 7-2: Single chip Mode pin settings

Chapter 8. Programming Methods

The board is intended for use with High-performance Embedded Workshop and the supplied E8a debugger. Refer to R8C/35C Group Hardware Manual for details of programming the microcontroller without using these tools.

Chapter 9. Headers

9.1. Microcontroller Headers

Table 9-1 to Table 9-4 show the microcontroller pin headers and their corresponding microcontroller connections. The header pins connect directly to the microcontroller pin unless otherwise stated.

J1					
Pin	Circuit Net Name	Device Pin	Pin	Circuit Net Name	Device Pin
1	UD	1	2	TRIGb	2
3	TMR1	3	4	VREF	4
5	MODE	5	6	CON_XCIN	6
7	CON_XCOUT	7	8	RESETn	8
9	CON_XOUT	9	10	Ground	10
11	CON_XIN	11	12	UC_VCC	12
13	PIN13	13	14	(Not used)	-

Table 9-1: J1

J2					
Pin	Circuit Net Name	Device Pin	Pin	Circuit Net Name	Device Pin
1	PIN14	14	2	LED2	15
3	LED1	16	4	Wn	17
5	Vn	18	6	Wp	19
7	Vp	20	8	Un	21
9	Up	22	10	TMR0	23
11	TRIGa	24	12	LED3	25
13	LED0	26	14	(Not used)	-

Table 9-2: J2

J3					
Pin	Circuit Net Name	Device Pin	Pin	Circuit Net Name	Device Pin
1	INT3n	27	2	INT2n	28
3	DLCDRS	29	4	ADTRGn_INT0n	30
5	INT1n	31	6	LINNSLP	32
7	LINRXD	33	8	LINTXD	34
9	AN11	35	10	AN10	36
11	AN9	37	12	AN8	38
13	DA1_IO7	39	14	(Not used)	-

Table 9-3: J3

J4					
Pin	Circuit Net Name	Device Pin	Pin	Circuit Net Name	Device Pin
1	DA0_IO6	40	2	IO5	41
3	IO4	42	4	IO3_CLK1	43
5	IO2_RXD1	44	6	IO1_TXD1	45
7	IO0	46	8	DLCDE	47
9	DLCDD7	48	10	DLCDD6	49
11	DLCDD5	50	12	DLCDD4	51
13	TRISTn	52	14	(Not used)	-

Table 9-4: J4

9.2. Application Headers

Table 9-5 and Table 9-6 below show the standard application header connections. * Marked pins are subject to option links.

JA1							
Pin	Header Name	Circuit Net Name	Device Pin	Pin	Header Name	Circuit Net Name	Device Pin
1	Regulated Supply 1	CON_5V	-	2	Regulated Supply 1	Ground	-
3	Regulated Supply 2	CON_3V3	-	4	Regulated Supply 2	Ground	-
5	Analog Supply	NC	-	6	Analog Supply	NC	-
7	Analog Reference	CON_VREF	4	8	ADTRG	ADTRGn*	30
9	AD0	AN8	38	10	AD1	AN9	37
11	AD2	AN10	36	12	AD3	AN11	35
13	DAC0	DA0*	40	14	DAC1	DA1*	39
15	IOPort0	IO0	46	16	IOPort1	IO1*	45
17	IOPort2	IO2*	44	18	IOPort3	IO3*	43
19	IOPort4	IO4	42	20	IOPort5	IO5	41
21	IOPort6	IO6*	40	22	IOPort7	IO7*	39
23	IRO3	INT3n	27	24	IIC_EX	NC	-
25	IIC_SDA	SDA	13	26	IIC_SCL	SCL	14

Table 9-5: JA1 Standard Generic Header

JA2							
Pin	Header Name	Circuit Net Name	Device Pin	Pin	Header Name	Circuit Net Name	Device Pin
1	Reset	RESETn	8	2	External Clock Input	CON_XOUT	9
3	Interrupt	NC	-	4	Regulated Supply 1	Ground	-
5	WDT overflow	NC	-	6	Serial Port	TXD1*	45
7	IRO0	INT0n*	30	8	Serial Port	RXD1*	44
9	IRO1	INT1n	31	10	Serial Port	CLK1*	43
11	Motor up/down	UD	1	12	Serial Port Handshake	NC	-
13	Motor control	Up	22	14	Motor control	Un	21
15	Motor control	Vp	20	16	Motor control	Vn	18
17	Motor control	Wp	19	18	Motor control	Wn	17
19	Timer Output	TMR0	23	20	Timer Output	TMR1	3
21	Timer Input	TRIGa	24	22	Timer Input	TRIGb	2
23	IRO2	INT2n	28	24	Tristate Control	TRISTn	52
25	SPARE	NC	-	26	SPARE	NC	-

Table 9-6: JA2 Standard Generic Header

Table 9-7 below show the LIN header connections.

J9		
Pin	Function	Signal Name
1	Power Supply (for LIN module)	VBAT
2	Ground	Ground
LIN		
Pin	Function	Signal Name
1	Power Supply (for LIN module)	VBAT
2	LIN Bus Line	LIN
3	Ground	Ground

Table 9-7: LIN Headers

Chapter 10.Code Development

10.1. Overview

Note: For all code debugging using Renesas software tools, the Renesas Starter Kit board must be connected to a Personal Computer USB port via an E8a. An E8a is supplied with the Renesas Starter Kit product.

10.2. Compiler Restrictions

The compiler supplied with this Renesas Starter Kit is fully functional for a period of 60 days from first use. After the first 60 days of use have expired, the compiler will default to a maximum of 64k code and data. To use the compiler with programs greater than this size you need to purchase the full tools from your distributor.

Warning: The protection software for the compiler will detect changes to the system clock. Changes to the system clock back in time may cause the trial period to expire prematurely.

10.3. Mode Support

High-performance Embedded Workspace connects to the Microcontroller and programs it via the E8a. Mode support is handled transparently to the user.

10.4. Breakpoint Support

High-performance Embedded Workshop supports breakpoints on the user code, both in RAM and ROM.

Double clicking in the breakpoint column in the code sets the breakpoint. Breakpoints will remain unless they are double clicked to remove them.

10.5. Memory Map

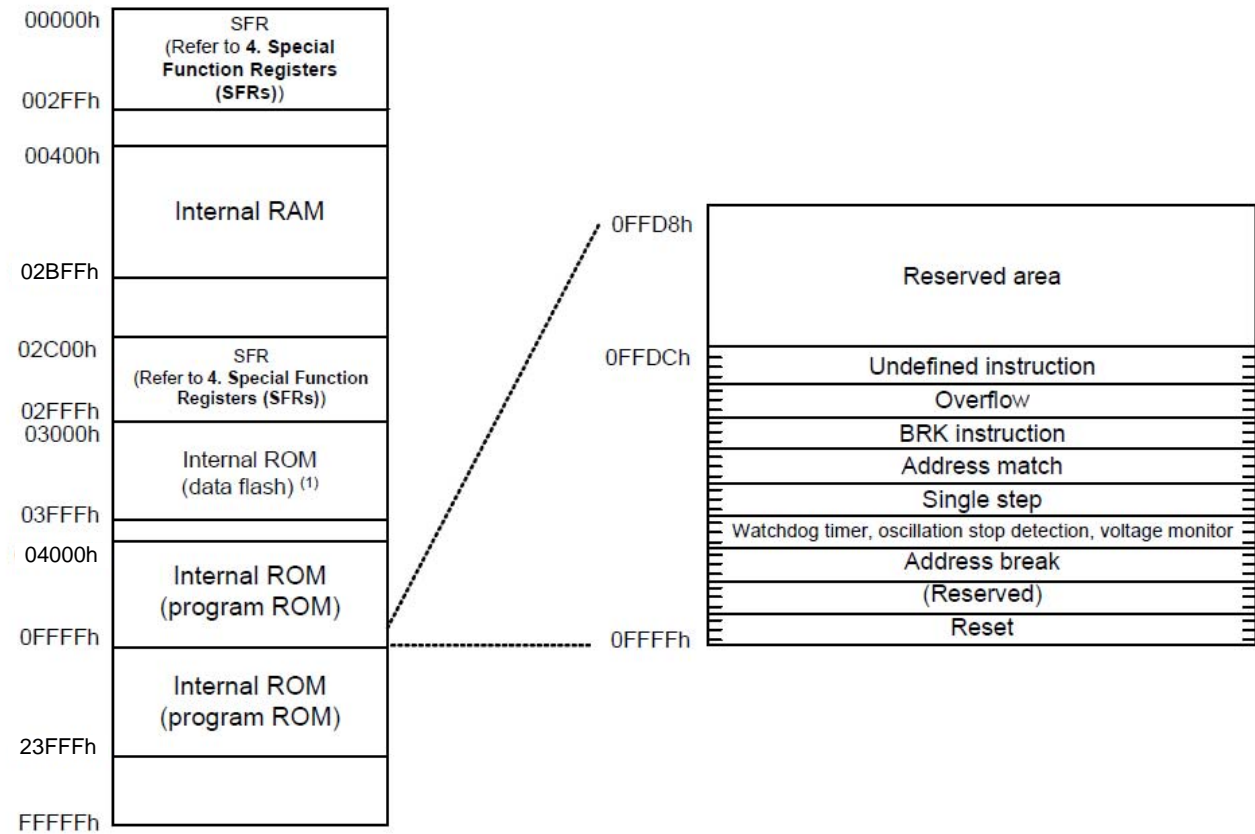

Figure 10-1 : Memory Map for R5F2135CCDFP (ROM: 128K+4K, RAM: 10K)

Chapter 11. Component Placement

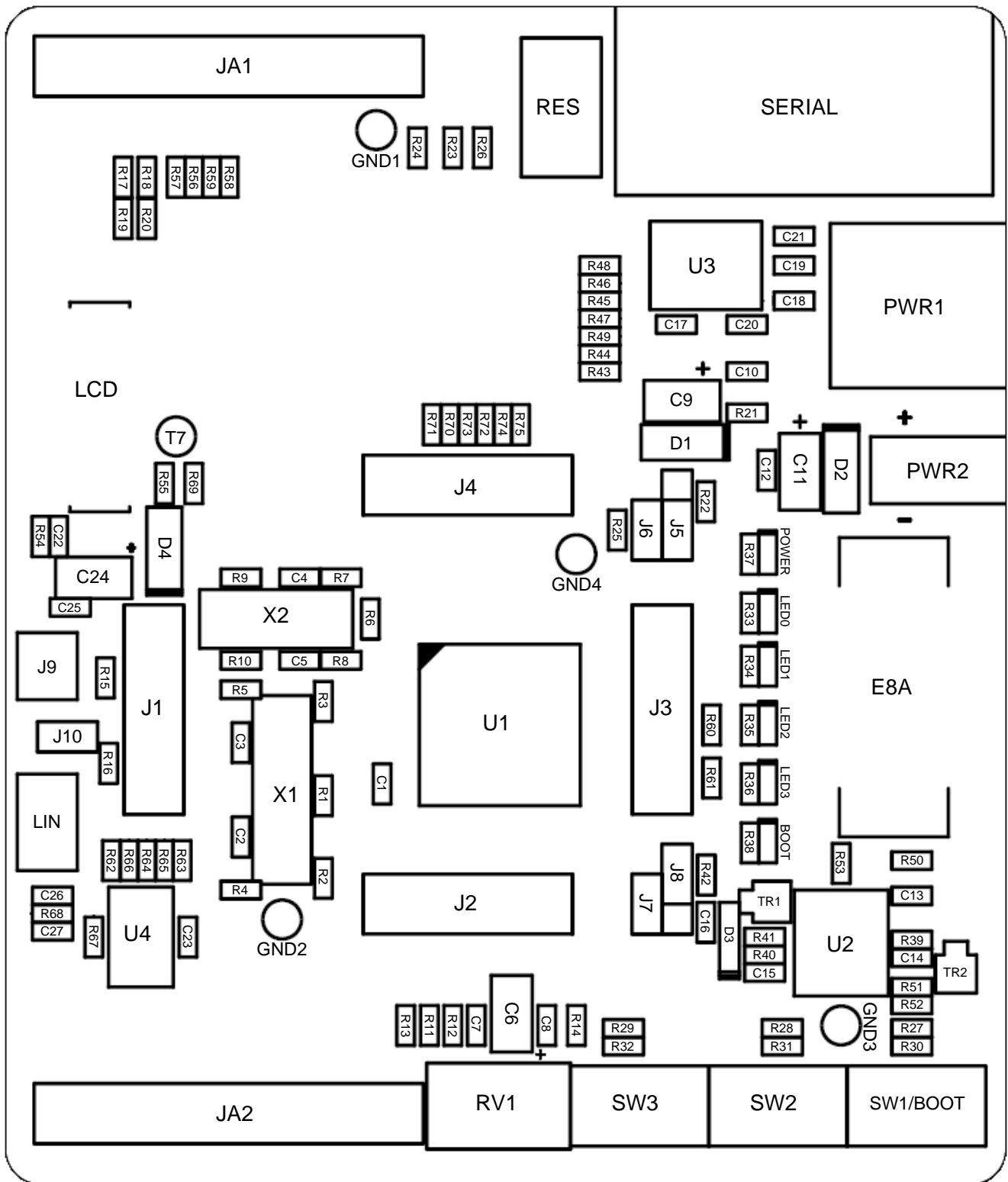

Figure 11-1 : Component Placement

Chapter 12. Additional Information

For details on how to use High-performance Embedded Workshop, refer to the High-performance Embedded Workshop manual available on the CD or from the web site.

For information about the R8C/35C group microcontrollers, refer to the R8C/35C Group Hardware Manual.

For information about the R8C/35C assembly language, refer to the R8C Family Software Programming Manual.

For information about the E8a Emulator, please refer to the E8A-USB Emulator User's Manual.

Online technical support and information is available at:

http://www.renesas.com/renesas_starter_kits

Technical Contact Details

America: techsupport.america@renesas.com

Europe: tools.support.eu@renesas.com

Japan: csc@renesas.com

General information on Renesas Microcontrollers can be found on the Renesas website at:

<http://www.renesas.com/>.

Renesas Starter Kit for R8C/35C

User's Manual

Publication Date Rev.1.00 01.Apr.2010

Published by: Renesas Electronics Europe Ltd.
Duke's Meadow, Millboard Road, Bourne End
Buckinghamshire SL8 5FH, United Kingdom

©2010 Renesas Electronics Europe and Renesas Solutions Corp., All Rights Reserved.

Renesas Starter Kit for R8C/35C
User's Manual

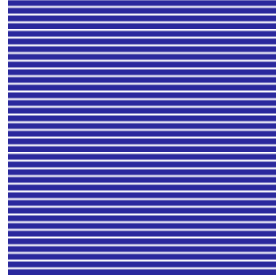

Renesas Electronics Europe Ltd.

Dukes Meadow, Millboard Road, Bourne End, Buckinghamshire, SL8 5FH, United Kingdom