

To our customers,

Old Company Name in Catalogs and Other Documents

On April 1st, 2010, NEC Electronics Corporation merged with Renesas Technology Corporation, and Renesas Electronics Corporation took over all the business of both companies. Therefore, although the old company name remains in this document, it is a valid Renesas Electronics document. We appreciate your understanding.

Renesas Electronics website: <http://www.renesas.com>

April 1st, 2010
Renesas Electronics Corporation

Issued by: Renesas Electronics Corporation (<http://www.renesas.com>)

Send any inquiries to <http://www.renesas.com/inquiry>.

Notice

1. All information included in this document is current as of the date this document is issued. Such information, however, is subject to change without any prior notice. Before purchasing or using any Renesas Electronics products listed herein, please confirm the latest product information with a Renesas Electronics sales office. Also, please pay regular and careful attention to additional and different information to be disclosed by Renesas Electronics such as that disclosed through our website.
2. Renesas Electronics does not assume any liability for infringement of patents, copyrights, or other intellectual property rights of third parties by or arising from the use of Renesas Electronics products or technical information described in this document. No license, express, implied or otherwise, is granted hereby under any patents, copyrights or other intellectual property rights of Renesas Electronics or others.
3. You should not alter, modify, copy, or otherwise misappropriate any Renesas Electronics product, whether in whole or in part.
4. Descriptions of circuits, software and other related information in this document are provided only to illustrate the operation of semiconductor products and application examples. You are fully responsible for the incorporation of these circuits, software, and information in the design of your equipment. Renesas Electronics assumes no responsibility for any losses incurred by you or third parties arising from the use of these circuits, software, or information.
5. When exporting the products or technology described in this document, you should comply with the applicable export control laws and regulations and follow the procedures required by such laws and regulations. You should not use Renesas Electronics products or the technology described in this document for any purpose relating to military applications or use by the military, including but not limited to the development of weapons of mass destruction. Renesas Electronics products and technology may not be used for or incorporated into any products or systems whose manufacture, use, or sale is prohibited under any applicable domestic or foreign laws or regulations.
6. Renesas Electronics has used reasonable care in preparing the information included in this document, but Renesas Electronics does not warrant that such information is error free. Renesas Electronics assumes no liability whatsoever for any damages incurred by you resulting from errors in or omissions from the information included herein.
7. Renesas Electronics products are classified according to the following three quality grades: "Standard", "High Quality", and "Specific". The recommended applications for each Renesas Electronics product depends on the product's quality grade, as indicated below. You must check the quality grade of each Renesas Electronics product before using it in a particular application. You may not use any Renesas Electronics product for any application categorized as "Specific" without the prior written consent of Renesas Electronics. Further, you may not use any Renesas Electronics product for any application for which it is not intended without the prior written consent of Renesas Electronics. Renesas Electronics shall not be in any way liable for any damages or losses incurred by you or third parties arising from the use of any Renesas Electronics product for an application categorized as "Specific" or for which the product is not intended where you have failed to obtain the prior written consent of Renesas Electronics. The quality grade of each Renesas Electronics product is "Standard" unless otherwise expressly specified in a Renesas Electronics data sheets or data books, etc.

"Standard": Computers; office equipment; communications equipment; test and measurement equipment; audio and visual equipment; home electronic appliances; machine tools; personal electronic equipment; and industrial robots.

"High Quality": Transportation equipment (automobiles, trains, ships, etc.); traffic control systems; anti-disaster systems; anti-crime systems; safety equipment; and medical equipment not specifically designed for life support.

"Specific": Aircraft; aerospace equipment; submersible repeaters; nuclear reactor control systems; medical equipment or systems for life support (e.g. artificial life support devices or systems), surgical implantations, or healthcare intervention (e.g. excision, etc.), and any other applications or purposes that pose a direct threat to human life.

8. You should use the Renesas Electronics products described in this document within the range specified by Renesas Electronics, especially with respect to the maximum rating, operating supply voltage range, movement power voltage range, heat radiation characteristics, installation and other product characteristics. Renesas Electronics shall have no liability for malfunctions or damages arising out of the use of Renesas Electronics products beyond such specified ranges.
9. Although Renesas Electronics endeavors to improve the quality and reliability of its products, semiconductor products have specific characteristics such as the occurrence of failure at a certain rate and malfunctions under certain use conditions. Further, Renesas Electronics products are not subject to radiation resistance design. Please be sure to implement safety measures to guard them against the possibility of physical injury, and injury or damage caused by fire in the event of the failure of a Renesas Electronics product, such as safety design for hardware and software including but not limited to redundancy, fire control and malfunction prevention, appropriate treatment for aging degradation or any other appropriate measures. Because the evaluation of microcomputer software alone is very difficult, please evaluate the safety of the final products or system manufactured by you.
10. Please contact a Renesas Electronics sales office for details as to environmental matters such as the environmental compatibility of each Renesas Electronics product. Please use Renesas Electronics products in compliance with all applicable laws and regulations that regulate the inclusion or use of controlled substances, including without limitation, the EU RoHS Directive. Renesas Electronics assumes no liability for damages or losses occurring as a result of your noncompliance with applicable laws and regulations.
11. This document may not be reproduced or duplicated, in any form, in whole or in part, without prior written consent of Renesas Electronics.
12. Please contact a Renesas Electronics sales office if you have any questions regarding the information contained in this document or Renesas Electronics products, or if you have any other inquiries.

(Note 1) "Renesas Electronics" as used in this document means Renesas Electronics Corporation and also includes its majority-owned subsidiaries.

(Note 2) "Renesas Electronics product(s)" means any product developed or manufactured by or for Renesas Electronics.

To all our customers

Regarding the change of names mentioned in the document, such as Hitachi Electric and Hitachi XX, to Renesas Technology Corp.

The semiconductor operations of Mitsubishi Electric and Hitachi were transferred to Renesas Technology Corporation on April 1st 2003. These operations include microcomputer, logic, analog and discrete devices, and memory chips other than DRAMs (flash memory, SRAMs etc.) Accordingly, although Hitachi, Hitachi, Ltd., Hitachi Semiconductors, and other Hitachi brand names are mentioned in the document, these names have in fact all been changed to Renesas Technology Corp. Thank you for your understanding. Except for our corporate trademark, logo and corporate statement, no changes whatsoever have been made to the contents of the document, and these changes do not constitute any alteration to the contents of the document itself.

Renesas Technology Home Page: <http://www.renesas.com>

Renesas Technology Corp.
Customer Support Dept.
April 1, 2003

Cautions

Keep safety first in your circuit designs!

1. Renesas Technology Corporation puts the maximum effort into making semiconductor products better and more reliable, but there is always the possibility that trouble may occur with them. Trouble with semiconductors may lead to personal injury, fire or property damage.
Remember to give due consideration to safety when making your circuit designs, with appropriate measures such as (i) placement of substitutive, auxiliary circuits, (ii) use of nonflammable material or (iii) prevention against any malfunction or mishap.

Notes regarding these materials

1. These materials are intended as a reference to assist our customers in the selection of the Renesas Technology Corporation product best suited to the customer's application; they do not convey any license under any intellectual property rights, or any other rights, belonging to Renesas Technology Corporation or a third party.
2. Renesas Technology Corporation assumes no responsibility for any damage, or infringement of any third-party's rights, originating in the use of any product data, diagrams, charts, programs, algorithms, or circuit application examples contained in these materials.
3. All information contained in these materials, including product data, diagrams, charts, programs and algorithms represents information on products at the time of publication of these materials, and are subject to change by Renesas Technology Corporation without notice due to product improvements or other reasons. It is therefore recommended that customers contact Renesas Technology Corporation or an authorized Renesas Technology Corporation product distributor for the latest product information before purchasing a product listed herein.
The information described here may contain technical inaccuracies or typographical errors. Renesas Technology Corporation assumes no responsibility for any damage, liability, or other loss rising from these inaccuracies or errors.
Please also pay attention to information published by Renesas Technology Corporation by various means, including the Renesas Technology Corporation Semiconductor home page (<http://www.renesas.com>).
4. When using any or all of the information contained in these materials, including product data, diagrams, charts, programs, and algorithms, please be sure to evaluate all information as a total system before making a final decision on the applicability of the information and products. Renesas Technology Corporation assumes no responsibility for any damage, liability or other loss resulting from the information contained herein.
5. Renesas Technology Corporation semiconductors are not designed or manufactured for use in a device or system that is used under circumstances in which human life is potentially at stake. Please contact Renesas Technology Corporation or an authorized Renesas Technology Corporation product distributor when considering the use of a product contained herein for any specific purposes, such as apparatus or systems for transportation, vehicular, medical, aerospace, nuclear, or undersea repeater use.
6. The prior written approval of Renesas Technology Corporation is necessary to reprint or reproduce in whole or in part these materials.
7. If these products or technologies are subject to the Japanese export control restrictions, they must be exported under a license from the Japanese government and cannot be imported into a country other than the approved destination.
Any diversion or reexport contrary to the export control laws and regulations of Japan and/or the country of destination is prohibited.
8. Please contact Renesas Technology Corporation for further details on these materials or the products contained therein.

H8S/2148, H8S/2148B, H8S/2138,
H8S/2128, H8/2140B, H8/2160B, H8/3577,
H8/3567 Series
E6000 Emulator HS2140EPI61H

Supplementary Information

Renesas Microcomputer Development
Environment System

Cautions

1. Hitachi neither warrants nor grants licenses of any rights of Hitachi's or any third party's patent, copyright, trademark, or other intellectual property rights for information contained in this document. Hitachi bears no responsibility for problems that may arise with third party's rights, including intellectual property rights, in connection with use of the information contained in this document.
2. Products and product specifications may be subject to change without notice. Confirm that you have received the latest product standards or specifications before final design, purchase or use.
3. Hitachi makes every attempt to ensure that its products are of high quality and reliability. However, contact Hitachi's sales office before using the product in an application that demands especially high quality and reliability or where its failure or malfunction may directly threaten human life or cause risk of bodily injury, such as aerospace, aeronautics, nuclear power, combustion control, transportation, traffic, safety equipment or medical equipment for life support.
4. Design your application so that the product is used within the ranges guaranteed by Hitachi particularly for maximum rating, operating supply voltage range, heat radiation characteristics, installation conditions and other characteristics. Hitachi bears no responsibility for failure or damage when used beyond the guaranteed ranges. Even within the guaranteed ranges, consider normally foreseeable failure rates or failure modes in semiconductor devices and employ systemic measures such as fail-safes, so that the equipment incorporating Hitachi product does not cause bodily injury, fire or other consequential damage due to operation of the Hitachi product.
5. This product is not designed to be radiation resistant.
6. No one is permitted to reproduce or duplicate, in any form, the whole or part of this document without written approval from Hitachi.
7. Contact Hitachi's sales office for any questions regarding this document or Hitachi semiconductor products.

IMPORTANT INFORMATION

READ FIRST

- **READ** this user's manual before using this emulator product.
- **KEEP** the user's manual handy for future reference.

Do not attempt to use the emulator product until you fully understand its mechanism.

Emulator Product:

Throughout this document, the term "emulator product" shall be defined as the following products produced only by Hitachi, Ltd. excluding all subsidiary products.

- Emulator station
- User system interface cables
- PC interface board
- Optional SIMM memory module
- E6000 expansion I/O board

The user system or a host computer is not included in this definition.

Purpose of the Emulator Product:

This emulator product is a software and hardware development tool for systems employing the Hitachi microcomputer H8S/2148, H8S/2148B, H8S/2138, H8S/2128, H8S/2140B, H8S/2160B, H8/3577, H8/3567 series (hereafter referred to as the MCU). The emulator product can be used for systems using other microcomputers by exchanging the evaluation chip. This emulator product must only be used for the above purpose.

Limited Applications:

This emulator product is not authorized for use in MEDICAL, atomic energy, aeronautical or space technology applications without consent of the appropriate officer of a Hitachi sales company. Such use includes, but is not limited to, use in life support systems. Buyers of this emulator product must notify the relevant Hitachi sales offices before planning to use the product in such applications.

Improvement Policy:

Hitachi, Ltd. (including its subsidiaries, hereafter collectively referred to as Hitachi) pursues a policy of continuing improvement in design, performance, and safety of the emulator product. Hitachi reserves the right to change, wholly or partially, the specifications, design, user's manual, and other documentation at any time without notice.

Target User of the Emulator Product:

This emulator product should only be used by those who have carefully read and thoroughly understood the information and restrictions contained in the user's manual. Do not attempt to use the emulator product until you fully understand its mechanism.

It is highly recommended that first-time users be instructed by users that are well versed in the operation of the emulator product.

LIMITED WARRANTY

Hitachi warrants its emulator products to be manufactured in accordance with published specifications and free from defects in material and/or workmanship. Hitachi, at its option, will repair or replace any emulator products returned intact to the factory, transportation charges prepaid, which Hitachi, upon inspection, determine to be defective in material and/or workmanship. The foregoing shall constitute the sole remedy for any breach of Hitachi's warranty. See the Hitachi warranty booklet for details on the warranty period. This warranty extends only to you, the original Purchaser. It is not transferable to anyone who subsequently purchases the emulator product from you. Hitachi is not liable for any claim made by a third party or made by you for a third party.

DISCLAIMER

HITACHI MAKES NO WARRANTIES, EITHER EXPRESS OR IMPLIED, ORAL OR WRITTEN, EXCEPT AS PROVIDED HEREIN, INCLUDING WITHOUT LIMITATION THEREOF, WARRANTIES AS TO MARKETABILITY, MERCHANTABILITY, FITNESS FOR ANY PARTICULAR PURPOSE OR USE, OR AGAINST INFRINGEMENT OF ANY PATENT. IN NO EVENT SHALL HITACHI BE LIABLE FOR ANY DIRECT, INCIDENTAL OR CONSEQUENTIAL DAMAGES OF ANY NATURE, OR LOSSES OR EXPENSES RESULTING FROM ANY DEFECTIVE EMULATOR PRODUCT, THE USE OF ANY EMULATOR PRODUCT, OR ITS DOCUMENTATION, EVEN IF ADVISED OF THE POSSIBILITY OF SUCH DAMAGES. EXCEPT AS EXPRESSLY STATED OTHERWISE IN THIS WARRANTY, THIS EMULATOR PRODUCT IS SOLD "AS IS", AND YOU MUST ASSUME ALL RISK FOR THE USE AND RESULTS OBTAINED FROM THE EMULATOR PRODUCT.

State Law:

Some states do not allow the exclusion or limitation of implied warranties or liability for incidental or consequential damages, so the above limitation or exclusion may not apply to you. This warranty gives you specific legal rights, and you may have other rights which may vary from state to state.

The Warranty is Void in the Following Cases:

Hitachi shall have no liability or legal responsibility for any problems caused by misuse, abuse, misapplication, neglect, improper handling, installation, repair or modifications of the emulator product without Hitachi's prior written consent or any problems caused by the user system.

All Rights Reserved:

This user's manual and emulator product are copyrighted and all rights are reserved by Hitachi. No part of this user's manual, all or part, may be reproduced or duplicated in any form, in hard-copy or machine-readable form, by any means available without Hitachi's prior written consent.

Other Important Things to Keep in Mind:

1. Circuitry and other examples described herein are meant merely to indicate the characteristics and performance of Hitachi's semiconductor products. Hitachi assumes no responsibility for any intellectual property claims or other problems that may result from applications based on the examples described herein.
2. No license is granted by implication or otherwise under any patents or other rights of any third party or Hitachi.

Figures:

Some figures in this user's manual may show items different from your actual system.

Limited Anticipation of Danger:

Hitachi cannot anticipate every possible circumstance that might involve a potential hazard. The warnings in this user's manual and on the emulator product are therefore not all inclusive. Therefore, you must use the emulator product safely at your own risk.

SAFETY PAGE

READ FIRST

- **READ** this user's manual before using this emulator product.
- **KEEP** the user's manual handy for future reference.

Do not attempt to use the emulator product until you fully understand its mechanism.

DEFINITION OF SIGNAL WORDS



This is the safety alert symbol. It is used to alert you to potential personal injury hazards. Obey all safety messages that follow this symbol to avoid possible injury or death.



DANGER indicates an imminently hazardous situation which, if not avoided, will result in death or serious injury.



WARNING indicates a potentially hazardous situation which, if not avoided, could result in death or serious injury.



CAUTION indicates a potentially hazardous situation which, if not avoided, may result in minor or moderate injury.



CAUTION used without the safety alert symbol indicates a potentially hazardous situation which, if not avoided, may result in property damage.

NOTE emphasizes essential information.

WARNING

Observe the precautions listed below. Failure to do so will result in a FIRE HAZARD and will damage the user system and the emulator product or will result in PERSONAL INJURY. The USER PROGRAM will be LOST.

- 1. Do not repair or remodel the emulator product by yourself for electric shock prevention and quality assurance.**
- 2. Always switch OFF the E6000 emulator and user system before connecting or disconnecting any CABLES or PARTS.**
- 3. Always before connecting any CABLES, make sure that pin 1 on both sides are correctly aligned.**
- 4. Supply power according to the power specifications and do not apply an incorrect power voltage. Use only the provided power cable.**

Preface

Thank you for purchasing the H8S/2148, H8S/2148B, H8S/2138, H8S/2128, H8S/2140B, H8S/2160B, H8/3577 and H8/3567 series E6000 emulator.

The H8S/2148, H8S/2148B, H8S/2138, H8S/2128, H8S/2140B, H8S/2160B, H8/3577 and H8/3567 series E6000 emulator (hereafter referred to as the E6000) was designed as a software and hardware development tool for systems based on Hitachi's original microcomputers HD6432148, HD64F2148B, HD6432138, HD6432128 series, HD64F2140B, HD64F2160B, HD6433577, HD6433567 series. The E6000 provides a CD-R that contains the Hitachi Debugging Interface (HDI) system program, test program, and the user's manual.

There are three manuals for the E6000: the H8S series E6000 Emulator User's Manual, the Supplementary Information, and the Hitachi Debugging Interface User's Manual. The E6000 Emulator User's Manual describes E6000 functions common to all H8S series microcomputers. The Supplementary Information describes the functions specialized for each microcomputer supported by the H8S/2148, H8S/2148B, H8S/2138, H8S/2128, H8S/2140B, H8S/2160B, H8/3577, H8/3567 series E6000 emulator. Please read this manual before using the E6000.

To connect the E6000 to the user system, the user system interface cable for each package type is available. For details on the user system interface cable, refer to the User System Interface Cable User's Manual.

The following shows the related manuals:

- H8S Series E6000 Emulator User's Manual (HS2000EPI61HE)
- Hitachi Debugging Interface User's Manual (HS6400DIIW5SE)
- User System Interface Cable User's Manual (HS2148ECH61HE, etc)
- The PC interface board user's manual which will be the following manuals:
 - ISA Bus Interface Board User's Manual (HS6000EII01HE)
 - PCI Bus Interface Board User's Manual (HS6000EIC01HE, HS6000EIC02HE)
 - PCMCIA Interface Card User's Manual (HS6000EIP01HE)
 - LAN Adapter (HS6000ELN01H)
- Optional Memory Board User's Manual
 - 4M SIMM Memory Board User's Manual (HS6000EMS12HE)

Note: Microsoft® and Windows® are registered trademarks of Microsoft Corporation in the United States and/or in other countries.

Contents

Section 1	Overview	1
1.1	Environment Conditions	1
1.2	Supported MCUs and User System Interface Cables.....	2
1.3	Operating Voltage and Frequency Specifications	5
Section 2	User System Interface.....	7
2.1	Signal Protection.....	7
2.2	User System Interface Circuits.....	7
Section 3	Notes on Use.....	11
3.1	I/O Register Differences between Actual MCU and E6000	11
3.2	Access to the Reserved Area and Internal RAM.....	11
3.3	Support of Flash Memory	12
3.4	Hardware Standby.....	12
Section 4	HDI Parameters	13
4.1	Address Areas	13
4.2	Access Status	14
4.3	I/O Module Selection.....	15
Section 5	Diagnostic Test Procedure.....	17
5.1	System Set-Up for Test Program Execution	17
5.2	Diagnostic Test Procedure Using the Test Program.....	18

Figures

Figure 2.1	Default User System Interface Circuit.....	8
Figure 2.2	User System Interface Circuit for MD1, MD0, and NMI.....	8
Figure 2.3	User System Interface Circuit for RESET.....	8
Figure 2.4	User System Interface Circuit for P40 to P47, P50 to P52, P60 to P67, P70 to P77, P80 to P86, PA0 to PA7, AN0 to AN7, DA0, DA1, AVcc, AVss, and Vref Signals	9
Figure 2.5	IRQ0–IRQ7 and WAIT User System Interface Circuit.....	9

Tables

Table 1.1	Environment Conditions.....	1
Table 1.2	H8S/2148, H8S/2148B Series MCUs and User System Interface Cable.....	2
Table 1.3	H8S/2138 Series MCUs and User System Interface Cables.....	2
Table 1.4	H8S/2128 Series MCUs and User System Interface Cables.....	3
Table 1.5	H8S/2140B MCUs and User System Interface Cables.....	3
Table 1.6	H8S/2160B MCUs and User System Interface Cables.....	3
Table 1.7	H8/3577 Series MCUs and User System Interface Cables.....	4
Table 1.8	H8/3567 Series MCUs and User System Interface Cables.....	4
Table 1.9	Operating Voltage and Frequency Specifications.....	5
Table 1.10	Clock Selections	6
Table 4.1	Address Area Parameters.....	13
Table 4.2	Access Status Parameters.....	14
Table 4.3	I/O Modules.....	15

Section 1 Overview

The H8S/2148, H8S2148B, H8S/2138, H8S/2128, H8S/2140B, H8S/2160B, H8/3577 and H8/3567 series E6000 emulator (hereafter referred to as the E6000) is an efficient software and hardware development support tool for application systems using Hitachi's original microcomputers H8S/2148, H8S/2148B, H8S/2138, H8S/2128, H8S/2140B, H8S/2160B, H8/3577 and H8/3567 series.

1.1 Environment Conditions

Table 1.1 Environment Conditions

Item	Specifications
Temperature	Operating: +10 to +35°C
	Storage: -10 to +50°C
Humidity	Operating: 35 to 80% RH; no condensation
	Storage: 35 to 80% RH; no condensation
Ambient gases	No corrosive gases
AC Power supply voltage	100 V to 240 V AC \pm 5% 50/60 Hz 0.6 A max.
User system voltage (UVcc)	Depends on the target MCU within the range 2.7 V to 5.5 V

1.2 Supported MCUs and User System Interface Cables

Tables 1.2 to 1.8 show the correspondence between the MCUs and the user system interface cables supported by the E6000.

H8S/2148, H8S/2148B Series:

Table 1.2 H8S/2148, H8S/2148B Series MCUs and User System Interface Cable

No.	MCU Type Number	Package	E6000 User System Interface Cables
1	HD6432148S/SW	100-pin QFP	HS2148ECH61H
	HD64F2148/48A/48B	(FP-100B),	
	HD6432147S/SW	100-pin TQFP	
	HD64F2147A/47N	(TFP-100B)	
	HD64F2145B		
	HD6432144S		
	HD64F2144/44A		
	HD6432143S		
	HD6432142		
	HD64F2142R		

H8S/2138 Series:

Table 1.3 H8S/2138 Series MCUs and User System Interface Cables

No.	MCU Type Number	Package	E6000 User System Interface Cables
1	HD6432138S/SW	80-pin QFP	HS2138ECH61H
	HD64F2138/38V/38A	(FP-80A)	
	HD6432137S/SW		
2	HD6432134S	80-pin TQFP (TFP-80C)	HS2138ECN61H
	HD64F2134/34V/34A		
	HD6432133S		
	HD6432132		
	HD64F2132R		
	HD6432130		

H8S/2128 Series:

Table 1.4 H8S/2128 Series MCUs and User System Interface Cables

No.	MCU Type Number	Package	E6000 User System Interface Cables
1	HD64F2128 HD6432127R/RW HD6432126R/RW	64-pin SDIP (DP-64S)	HS2128ECS61H
2	HD6432122 HD6432120	64-pin QFP (FP-64A)	HS2128ECH61H
3		80-pin TQFP (TFP-80C)	HS2128ECN61H

H8S/2140B Series:

Table 1.5 H8S/2140B Series MCUs and User System Interface Cables

No.	MCU Type Number	Package	E6000 User System Interface Cables
1	HD64F2140B HD64F2141B HD64F2145BV	100-pin QFP (FP-100B), 100-pin TQFP (TFP-100B)	HS2148ECH61H

Note: When emulating the H8S/2140B series the H8S/2140B E6000 expansion I/O board (HS2140EIO61H) and the E6000 are required.

H8S/2160B Series:

Table 1.6 H8S/2160B Series MCUs and User System Interface Cables

No.	MCU Type Number	Package	E6000 User System Interface Cables
1	HD64F2160B	144-pin TQFP (TFP-144)	HS2169ECN61H

Note: When emulating the H8S/2160B series E6000 expansion I/O board (HS2160EIO61H) and the E6000 are required.

H8/3577 Series:**Table 1.7 H8/3577 Series MCUs and User System Interface Cables**

No.	MCU Type Number	Package	E6000 User System Interface Cables
1	HD6433577 HD6473577	64-pin SDIP (DP-64S)	HS2128ECS61H
2	HD6433574	64-pin QFP (FP-64A)	HS2128ECH61H

H8/3567 Series:**Table 1.8 H8/3567 Series MCUs and User System Interface Cables**

No.	MCU Type Number	Package	E6000 User System Interface Cables
1	HD6433567 HD6473567 HD6433564	42-pin SDIP (DP-42S)	HS3567ECS61H
2	HD6433567U HD6473567U	64-pin SDIP (DP-64S)	HS3567UECS61H (Cable with USB function)
3	HD6433564U	64-pin QFP (FP-64A)	HS3567UECH61H (Cable with USB function)

1.3 Operating Voltage and Frequency Specifications

Table 1.9 shows the MCU operating voltage and frequency specifications supported by the E6000. Note that some MCUs do not operate at neither a low voltage nor a high frequency.

Table 1.9 Operating Voltage and Frequency Specifications

No.	MCU Types	Operating Voltage (V)	Operating Frequency Range (ϕ) (MHz)
1	H8S/2148 series	2.7-4.0	2-10
	H8S/2148B series	4.0-4.5	2-16
	H8S/2138 series	4.5-5.5	2-20
	H8S/2128 series		
2	H8S/2140B series	2.7-3.6	2-10
	H8S/2160B series		
3	H8/3577 series	4.5-5.5	2-20
	H8/3567 series (except for the HD6433564-10 listed below)		
4	HD6433564-10	4.5-5.5	2-10

NOTE

For details on the operating voltage and frequency specifications, refer to the MCU hardware manual.

In the E6000, the clock can be selected by using the Configuration dialog box or the Clock command.

Table 1.10 Clock Selections

Clock Command Parameter	Configuration Dialog Box Setting	Notes
8	8 MHz internal clock	
10	10 MHz internal clock	Default
12	12.5 MHz internal clock	
16	16 MHz internal clock	
20	20 MHz internal clock	
t	Target	
t2	Target/2	Not supported by the actual MCU. Use this clock only when the required clock duty cannot be obtained.

NOTE

The system clock (ϕ) frequency is the same clock frequency input to the XTAL and EXTAL when external clock t is specified. For example, when a 20-MHz crystal oscillator is connected to the XTAL and EXTAL of the user system, the system clock (ϕ) frequency is 20 MHz. When external clock t2 is specified, the system clock (ϕ) frequency is 1/2 of the clock frequency input to the XTAL and EXTAL.

The frequency of the E6000 internal clock specified with the HDI CLOCK command is applied to the system clock (ϕ).

Section 2 User System Interface

All user system interface signals are directly connected to the MCU in the E6000 with no buffering except for those listed below which are connected to the MCU through control circuits:

- NMI
- RESET
- MD1, MD0
- XTAL
- EXTAL
- WAIT

2.1 Signal Protection

All user system interface signals are protected from over- or under-voltage by use of diode arrays except for the AVcc and Vref.

Pull-up resistors are connected to the port signals except for the analog port signals.

The Vcc signals (except for AVcc signals) at the head of the user system interface cable are connected together, which is monitored by the E6000 to detect whether the user system hardware is connected.

2.2 User System Interface Circuits

The interface circuit between the MCU in the E6000 and the user system has a signal delay of about 8 ns due to the user system interface cable and it includes pull-up resistors. Therefore, high-impedance signals will be pulled up to the high level. When connecting the E6000 to a user system, adjust the user system hardware to compensate for propagation delays.

The following diagrams show the equivalent circuit examples of the interface signals.

Default:

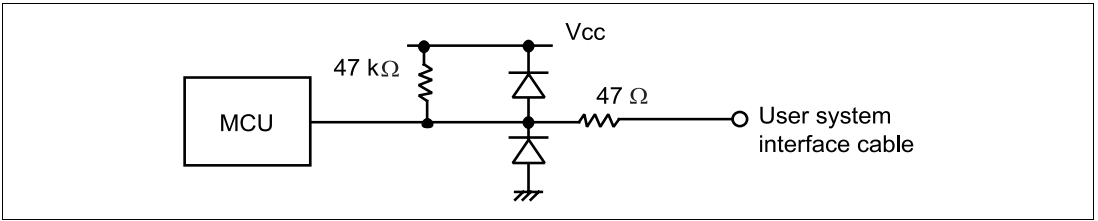

Figure 2.1 Default User System Interface Circuit

Mode Pins (MD1 and MD0) and NMI: The NMI signal is input to the MCU through the emulator control circuit. The rising/falling time of these signals must be 8 ns/V or less. The mode pins are only monitored. The CPU mode depends on the HDI settings.

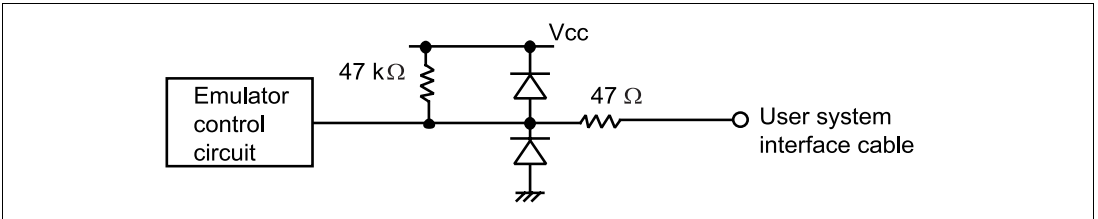

Figure 2.2 User System Interface Circuit for MD1, MD0, and NMI

RESET:

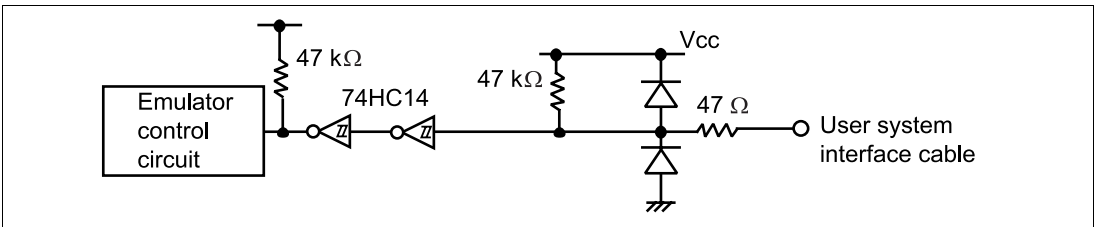

Figure 2.3 User System Interface Circuit for RESET

P40 to P47, P50 to P52, P60 to P67, P70 to P77, P80 to P86, P90 to P97, PA0 to PA7, AN0 to AN7, DA0, DA1, AVcc, AVss, and Vref:

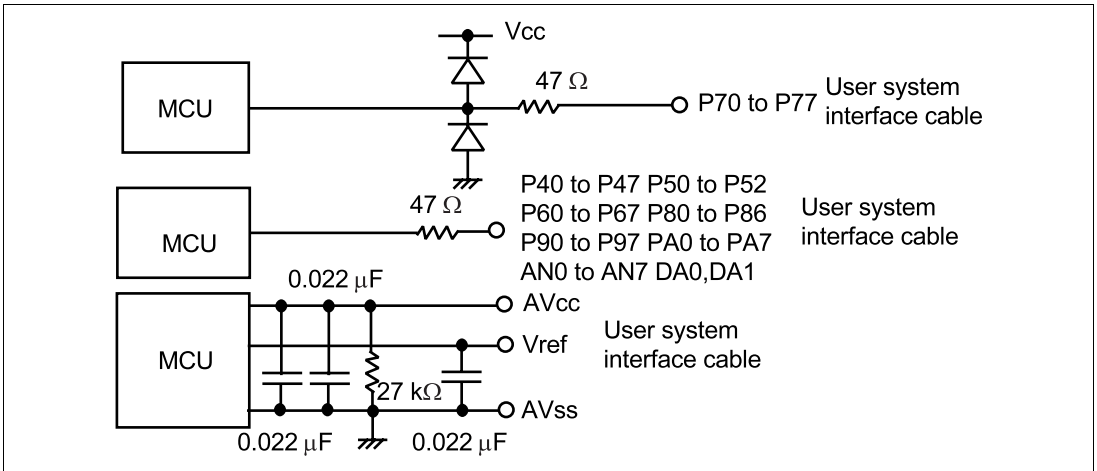

Figure 2.4 User System Interface Circuit for P40 to P47, P50 to P52, P60 to P67, P70 to P77, P80 to P86, P90 to P97, PA0 to PA7, AN0 to AN7, DA0, DA1, AVcc, AVss, and Vref Signals

IRQ0–IRQ7 and WAIT: The IRQ0 to IRQ7 and WAIT signals are input to the MCU and also to the trace acquiring circuit. Therefore, the rising and falling time of these signals must be within 8 ns/v or shorter.

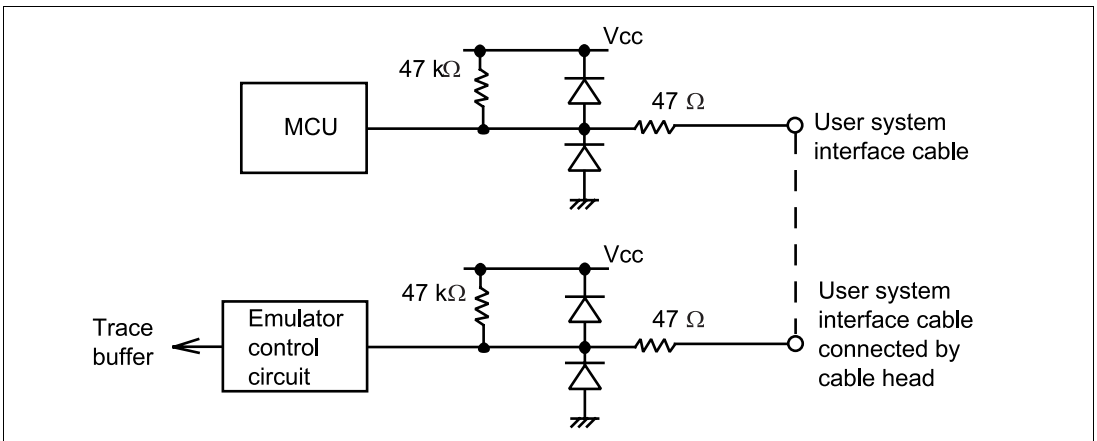

Figure 2.5 IRQ0–IRQ7 and WAIT User System Interface Circuit

Section 3 Notes on Use

3.1 I/O Register Differences between Actual MCU and E6000

In the E6000, one evaluation chip emulates several types of MCU. Therefore, there are some differences in I/O registers between an actual MCU and the E6000. Note these differences when accessing the I/O registers.

I/O port is in the input state at default. The I/O register contents indicate the emulator port status. When the user system interface cable is not connected, the read value is 1 due to pull-up resistors.

In the E6000, accesses to the following registers for controlling the flash memory in the H8S/2148, H8S/2148B, H8S/2138, H8S/2128, H8S/2140B, H8S/2160B, H8/3577, H8/3567 series are invalid.

- Flash memory control register 1 (FLMCR1: FF80)
- Flash memory control register 2 (FLMCR2: FF81)
- Erase block register 1 (EBR1: FF82)
- Erase block register 2 (EBR2: FF83)
- Serial timer control register (STCR: H'FFC3)
(Accesses to the FLSHE bit are invalid)

3.2 Access to the Reserved Area and Internal RAM

When accessing the reserved area and internal RAM, note the following:

1. Part of the reserved area (specified in each MCU's memory map) can be used as an external address area when the RAME bit of the SYSCR is cleared to 0. Target (user memory) or Emulator (optional memory) can be specified for this area with the Configuration settings.
2. If the reserved area other than that described in item 1 above is used, the operation in the actual MCU cannot be guaranteed. If the user program extends to the reserved area during debugging, select the MCU having the largest ROM capacity (for example, debug the H8S/2144 program in the H8S/2148 mode).
3. Internal RAM (specified in each MCU's memory map) can be used as an external address area when the RAME bit of the SYSCR is cleared to 0. Target (user memory) can be specified for this area with the Configuration settings.

3.3 Support of Flash Memory

The E6000 does not emulate the flash memory in the MCU.

3.4 Hardware Standby

When the User Standby enable check box is selected in the Configuration window, the STBY signal on the user system is directly input to the E6000.

When the STBY signal is input, the E6000 hardware is initialized and the E6000 stops emulation. In such a case, terminate the HDI and restart the E6000. Therefore, we recommend to clear the User Standby enable check box (not selected) for general emulation.

Section 4 HDI Parameters

4.1 Address Areas

Table 4.1 lists the parameters for address areas (Area) that can be specified with HDI command line interface (Breakpoint command etc.) or displayed as trace results.

Table 4.1 Address Area Parameters

HDI Parameter (Trace Display)	Address Area	Description
rom (ROM)	On-chip ROM	MCU's on-chip ROM, which can be read but cannot be written to.
ram (RAM)	On-chip RAM	MCU's on-chip RAM (except for DTC RAM), which can be read and written to.
IO16 (I/O-16)	Internal I/O registers (16-bit bus)	MCU's internal I/O registers for the 16-bit bus.
IO8 (I/O-8)	Internal I/O registers (8-bit bus)	MCU's internal I/O registers for the 8-bit bus.
ext16 (EXT-16)	External area (16-bit bus)	External area for the 16-bit bus, which can be allocated to the user system memory or the optional SIMM memory module in the E6000.
ext8 (EXT-8)	External area (8-bit bus)	External area for the 8-bit bus, which can be allocated to the user system memory or the optional SIMM memory module in the E6000.
Dtcram (RAM/DTC)	DTC RAM	MCU's on-chip RAM for DTC.

4.2 Access Status

Table 4.2 lists the parameters for access status (Status) that can be specified with HDI command line interface (Breakpoint command etc.) or displayed as trace window results.

Table 4.2 Access Status Parameters

HDI Parameter (Trace Display)	Access Status	Description
dtc (DTC)	On-chip DTC	Access by the MCU's DTC
prefetch (PROG)	CPU prefetch	Instruction prefetch cycle by the CPU
data (DATA)	CPU data access	Data access for instruction execution by the CPU

4.3 I/O Module Selection

Table 4.3 lists the I/O modules that can be selected as Custom settings in the HDI command line interface (Modules command).

Table 4.3 I/O Modules

HDI Parameter	I/O Module
DTC	Data transfer controller (DTC)
TIMER	Timer connection
D/A	D/A converter
HIF	HIF (host interface), KMIMR (keyboard matrix interrupt mask), KMIMRA (keyboard matrix interrupt mask A), and KMPCR (port 6 pull-up MOS control)
TMR Y	Timer Y
TMR X	Timer X
A/D	A/D converter
IIC1	I ² C bus interface 1 (IIC1)
IIC0	I ² C bus interface 0 (IIC0)
PWM8	8-bit PWM timer (PWM)
PWM14	14-bit PWM timer (PWM X)
SCI2/IrDA	Serial communication interface 2 (SCI2/IrDA standard)
SCI1	Serial communication interface 1 (SCI1)
PS/2	Keyboard buffer controller (PS/2)

Section 5 Diagnostic Test Procedure

This section describes the diagnostic test procedure using the E6000 test program.

5.1 System Set-Up for Test Program Execution

To execute the test program, use the following hardware; do not connect the user system interface cable and user system.

- E6000 (HS2140EPI61H)
 - Host computer
 - The E6000 PC interface board which will be one of the following boards or card:
Select one interface board from the following depending on the PC interface specifications.
ISA bus interface board (HS6000EII01H)
PCI bus interface board (HS6000EIC01H, HS6000EIC02H)
PCMCIA interface card (HS6000EIP01H)
1. Install the E6000 PC interface board in the host computer and connect the supplied PC interface cable to the board.
 2. Connect the PC interface cable to the E6000.
 3. Connect the supplied AC adapter to the E6000.
 4. Initiate the host computer to make it enter DOS prompt command input wait state.
 5. Turn on the E6000 switch.

5.2 Diagnostic Test Procedure Using the Test Program

Insert the CD-R (HS2140EPI61SR supplied with the E6000) into CD-ROM drive of the host computer by pressing the Shift key, move the current directory to <Drive>:\Diag with a command prompt, and enter one of the following commands according to the PC interface board used to initiate the test program:

1. ISA bus interface board (HS6000EII01H)
>TM2148B –ISA (RET)
2. PCI bus interface board (HS6000EIC01H, HS6000EIC02H)
>TM2148B –PCI (RET)
3. PCMCIA interface card (HS6000EIP01H)
>TM2148B –PCCD (RET)

Be sure to initiate the test program from <Drive>:\Diag. Do not initiate it from a directory other than <Drive>:\Diag, such as <Drive>:\Diag\TM2148B –ISA (RET). If the test program is initiated when the current directory is not <Drive>:\Diag, the test program will not operate correctly.

When –S is added to the command line such as >TM2148B –ISA –S (RET), steps 1 to 18 will be repeatedly executed. To stop the execution, enter Q.

- Notes:
1. When the CD-R is inserted into the CD-ROM drive without pressing the Shift key, the HDI installation wizard is automatically started.
 2. <Drive> is a drive name for the CD-ROM drive.
 3. Do not remove the CD-R from the CD-ROM drive during text program execution.

It will take about 11 minutes to execute the test program when the host computer using Windows®95 runs at 166 MHz and the PCMCIA interface card is used. The following messages are displayed during the test.

Message	Description
E6000 H8S/2148B EMULATION BOARD Tests Vx.x Hitachi Ltd (1999)	Test program start message. Vx.x shows the version number.
Searching for interface cardOK, card at H'd0000	Shows that the PC interface board is correctly installed in the host computer, and displays the address when the ISA bus interface is installed. The displayed address depends on the settings. When the PCI interface board or PCMCIA interface card is installed, the address is not displayed.
Checking emulator is connectedOK	Shows that the E6000 is correctly connected to the host computer.
Emulator Board Information: Main Board ID H'5	Shows the ID number of the lower board of the E6000 (always 5).
Emulation Board ID H'16	Shows the ID number of the upper board of the E6000 (always 16).
Revision H'x	Shows the revision number of the upper board of the E6000.
SIMM No SIMM module inserted	Shows whether the SIMM memory board is installed.

Downloading firmware

Loading the test program.

01) Testing Main Board Register :

IDR0 Register.....OK
PAGE Register.....OK
TRACE G/A Register.....OK
PERFM G/A Register.....OK
CES GA registerOK
IDR1 Register.....OK

Shows the check results for the registers in the E6000 (normal completion).

02) Testing Dual-Port RAM :

Decode TestOK
Marching TestOK

Shows the results of decoding test and step test for the dual-port RAM in the E6000 (normal completion).

03) Testing Firmware RAM :

Decode Test. page range H'700 - H'71fOK

Shows the results of decoding test for the firmware RAM in the E6000 (normal completion).

Marching Test. page range H'700 - H'71fOK

Shows the results of step for the firmware RAM in the E6000 (normal completion).

Downloading firmware

Loading the test program.

04) Testing Trace RAM :

Decode Test. page range H'000 - H'04fOK

Shows the results of decoding test for the trace RAM (first half) in the E6000 (normal completion).

Marching Test. page range H'000 - H'04fOK

Shows the results of step test for the trace RAM (first half) in the E6000 (normal completion).

Decode Test. page range H'000 - H'04fOK

Shows the results of decoding test for the trace RAM (last half) in the E6000 (normal completion).

Marching Test. page range H'000 - H'04fOK

Shows the results of step test for the trace RAM (last

	half) in the E6000 (normal completion).
05) Testing Mapping RAM :	
Decode Test. page range H'200 - H'27fOK	Shows the results of decoding test for the mapping RAM in the E6000 (normal completion).
Marching Test. page range H'200 - H'27fOK	Shows the results of step test for the mapping RAM in the E6000 (normal completion).
06) Testing Internal ROM and RAM :	Shows the results of decoding test and step test for internal ROM and RAM in the E6000 (normal completion).
Setting up, please wait..	
Decode Test (H'00000000 - H'0003ffff)..OK	
Decode Test (H'00040000 - H'0007ffff)..OK	
Decode Test (H'00ffe080 - H'00ffefff)..OK	
Marching Test (H'00000000 - H'0003ffff)..OK	
Marching Test (H'00040000 - H'0007ffff)..OK	
Marching Test (H'00ffe080 - H'00ffefff)..OK	
07) Testing Option RAM :	Shows the check results for the optional SIMM memory module in the E6000 (not installed).
Setting up, please wait..	
No SIMM fitted - test skipped	
08) Testing STEP Operation :	Shows the check results for the step execution controlling circuits in the E6000 (normal completion).
Setting up, please wait..	
Step OperationOK	
09) Testing Key Break :	Shows the check results for the forced break controlling circuits in the E6000 (normal completion).
Setting up, please wait..	
Key BreakOK	
10) Testing Emulation RAM Hardware Break :	Shows the check results for the illegal access break controlling circuits in the E6000 (normal completion).
Setting up, please wait..	
GRD BreakOK	
Setting up, please wait..	
WPT BreakOK	
11) Testing Internal ROM Write-Protect :	Shows the check results for the internal ROM write-protection controlling
Setting up, please wait..	
Write-ProtectOK	

- circuits in the E6000 (normal completion).
- 12) Testing Hardware Break :
 Setting up, please wait..
 A)Break Point InitialisedOK
 B)Event Detectors CES channel 1-12 ...OK
 C)Test Sequencing 1OK
 D)Check Range BreakOK
 E)Check Range Break for DataOK
 F)Check Compare EitherOK
- Shows the check results for the hardware break control circuits in the E6000 (normal completion).
- 13) Testing Emulation RAM Trace :
 Setting up, please wait..
 A)Free Trace TestOK
 B)Range Trace TestOK
 C)Point to Point Trace TestOK
 D)Start and Stop Event Trace TestOK
 E)Trace memory Overflow TestOK
 F)Time STAMP Trace TestOK
 Time STAMP Trace Test 1OK
 Time STAMP Trace Test 2OK
 Time STAMP Trace Test 3OK
- Shows the check results for the trace controlling circuits in the E6000 (normal completion).
- 14) Testing Runtime counter :
 Setting up, please wait..
 Testing Internal Clock = 16.0 MHzOK
 Testing Internal Clock = 12.5 MHzOK
- Shows the check results for the run-time counter in the E6000 (normal completion).
- 15) Testing Emulation Monitor :
 Setting up, please wait..
 A)EMA23-EMA0(MONIT00:D7-D0,MONIT10,E:D7-D0)TEST..OK
 B)ACST2-ACST0(MONIT0E:D2-D0)TEST.....OK
 C)ST3-ST0(MONIT2E:D3-D0)TEST.....OK
 D)BRKACK(MONIT0E:D7)TEST.....OK
 E)CNN(MONIT3E:D1)TEST.....OK
 F)NOCLK(MONIT3E:D2)TEST.....OK
- Shows the check results for the emulation monitor controlling circuits in the E6000 (normal completion).

<p>16) Testing PERM_GA :</p> <p>Setting up, please wait..</p> <p>A)Time Measure TestOK</p> <p>B)PERM_POINT TO POINT Time Measure TestOK</p> <p>C)PERM_SUBROUTINE Time Measure TestOK</p> <p>D)PERM Time Out Bit Test</p> <p> Time Out Test 1.....OK</p> <p> Time Out Test 2.....OK</p> <p>17) Testing Bus Monitor :</p> <p>Setting up, please wait..</p> <p>A) Register test.....OK</p> <p>B) Parallel RAM test.....OK</p> <p>C) SPRSEL2 test.....OK</p> <p>Setting up, please wait..</p> <p>D) RAM monitor test.....OK</p> <p>18) Testing Parallel Access :</p> <p>A)IN ROM Parallel Read Access(WORD)OK</p> <p>B)IN ROM Parallel Write Access(WORD)OK</p> <p>C)IN ROM Parallel Write Access(High Byte) ...OK</p> <p>D)IN ROM Parallel Write Access(Low Byte)OK</p> <p>E)IN RAM Parallel Read Access(WORD)OK</p> <p>F)IN RAM Parallel Write Access(WORD)OK</p> <p>G)IN RAM Parallel Write Access(High Byte) ...OK</p> <p>H)IN RAM Parallel Write Access(Low Byte)OK</p> <p>I)SIMM Parallel Read Access(WORD)SKIP</p> <p>J)SIMM Parallel Write Access(WORD)SKIP</p> <p>K)SIMM Parallel Write Access(High Byte)SKIP</p> <p>L)SIMM Parallel Write Access(Low Byte)SKIP</p> <p>0 total errors</p> <p>Tests passed, emulator functioning correctly</p>	<p>Shows the check results for the performance analysis controlling circuits in the E6000 (nomal completion).</p> <p>Shows the check results for the bus monitor controlling circuits in the E6000 (normal completion).</p> <p>Shows the check results for the parallel access controlling circuits in the E6000 (normal completion).</p> <p>Total number of errors.</p> <p>Shows that the E6000 is correctly operating.</p>
--	--