

To our customers,

Old Company Name in Catalogs and Other Documents

On April 1st, 2010, NEC Electronics Corporation merged with Renesas Technology Corporation, and Renesas Electronics Corporation took over all the business of both companies. Therefore, although the old company name remains in this document, it is a valid Renesas Electronics document. We appreciate your understanding.

Renesas Electronics website: <http://www.renesas.com>

April 1st, 2010
Renesas Electronics Corporation

Issued by: Renesas Electronics Corporation (<http://www.renesas.com>)

Send any inquiries to <http://www.renesas.com/inquiry>.

Notice

1. All information included in this document is current as of the date this document is issued. Such information, however, is subject to change without any prior notice. Before purchasing or using any Renesas Electronics products listed herein, please confirm the latest product information with a Renesas Electronics sales office. Also, please pay regular and careful attention to additional and different information to be disclosed by Renesas Electronics such as that disclosed through our website.
2. Renesas Electronics does not assume any liability for infringement of patents, copyrights, or other intellectual property rights of third parties by or arising from the use of Renesas Electronics products or technical information described in this document. No license, express, implied or otherwise, is granted hereby under any patents, copyrights or other intellectual property rights of Renesas Electronics or others.
3. You should not alter, modify, copy, or otherwise misappropriate any Renesas Electronics product, whether in whole or in part.
4. Descriptions of circuits, software and other related information in this document are provided only to illustrate the operation of semiconductor products and application examples. You are fully responsible for the incorporation of these circuits, software, and information in the design of your equipment. Renesas Electronics assumes no responsibility for any losses incurred by you or third parties arising from the use of these circuits, software, or information.
5. When exporting the products or technology described in this document, you should comply with the applicable export control laws and regulations and follow the procedures required by such laws and regulations. You should not use Renesas Electronics products or the technology described in this document for any purpose relating to military applications or use by the military, including but not limited to the development of weapons of mass destruction. Renesas Electronics products and technology may not be used for or incorporated into any products or systems whose manufacture, use, or sale is prohibited under any applicable domestic or foreign laws or regulations.
6. Renesas Electronics has used reasonable care in preparing the information included in this document, but Renesas Electronics does not warrant that such information is error free. Renesas Electronics assumes no liability whatsoever for any damages incurred by you resulting from errors in or omissions from the information included herein.
7. Renesas Electronics products are classified according to the following three quality grades: “Standard”, “High Quality”, and “Specific”. The recommended applications for each Renesas Electronics product depends on the product’s quality grade, as indicated below. You must check the quality grade of each Renesas Electronics product before using it in a particular application. You may not use any Renesas Electronics product for any application categorized as “Specific” without the prior written consent of Renesas Electronics. Further, you may not use any Renesas Electronics product for any application for which it is not intended without the prior written consent of Renesas Electronics. Renesas Electronics shall not be in any way liable for any damages or losses incurred by you or third parties arising from the use of any Renesas Electronics product for an application categorized as “Specific” or for which the product is not intended where you have failed to obtain the prior written consent of Renesas Electronics. The quality grade of each Renesas Electronics product is “Standard” unless otherwise expressly specified in a Renesas Electronics data sheets or data books, etc.
 - “Standard”: Computers; office equipment; communications equipment; test and measurement equipment; audio and visual equipment; home electronic appliances; machine tools; personal electronic equipment; and industrial robots.
 - “High Quality”: Transportation equipment (automobiles, trains, ships, etc.); traffic control systems; anti-disaster systems; anti-crime systems; safety equipment; and medical equipment not specifically designed for life support.
 - “Specific”: Aircraft; aerospace equipment; submersible repeaters; nuclear reactor control systems; medical equipment or systems for life support (e.g. artificial life support devices or systems), surgical implantations, or healthcare intervention (e.g. excision, etc.), and any other applications or purposes that pose a direct threat to human life.
8. You should use the Renesas Electronics products described in this document within the range specified by Renesas Electronics, especially with respect to the maximum rating, operating supply voltage range, movement power voltage range, heat radiation characteristics, installation and other product characteristics. Renesas Electronics shall have no liability for malfunctions or damages arising out of the use of Renesas Electronics products beyond such specified ranges.
9. Although Renesas Electronics endeavors to improve the quality and reliability of its products, semiconductor products have specific characteristics such as the occurrence of failure at a certain rate and malfunctions under certain use conditions. Further, Renesas Electronics products are not subject to radiation resistance design. Please be sure to implement safety measures to guard them against the possibility of physical injury, and injury or damage caused by fire in the event of the failure of a Renesas Electronics product, such as safety design for hardware and software including but not limited to redundancy, fire control and malfunction prevention, appropriate treatment for aging degradation or any other appropriate measures. Because the evaluation of microcomputer software alone is very difficult, please evaluate the safety of the final products or system manufactured by you.
10. Please contact a Renesas Electronics sales office for details as to environmental matters such as the environmental compatibility of each Renesas Electronics product. Please use Renesas Electronics products in compliance with all applicable laws and regulations that regulate the inclusion or use of controlled substances, including without limitation, the EU RoHS Directive. Renesas Electronics assumes no liability for damages or losses occurring as a result of your noncompliance with applicable laws and regulations.
11. This document may not be reproduced or duplicated, in any form, in whole or in part, without prior written consent of Renesas Electronics.
12. Please contact a Renesas Electronics sales office if you have any questions regarding the information contained in this document or Renesas Electronics products, or if you have any other inquiries.

(Note 1) “Renesas Electronics” as used in this document means Renesas Electronics Corporation and also includes its majority-owned subsidiaries.

(Note 2) “Renesas Electronics product(s)” means any product developed or manufactured by or for Renesas Electronics.

Renesas Starter Kit

RSKH8/38347 User's Manual

RENEASAS SINGLE-CHIP MICROCOMPUTER
H8 FAMILY - H8/300L Super Low Power Series

Table of Contents

Chapter 1. Preface	3
Chapter 2. Purpose.....	4
Chapter 3. Power Supply	5
3.1. Requirements.....	5
3.2. Power – Up Behaviour	5
Chapter 4. Board Layout	6
4.1. Component Layout.....	6
4.2. Board Dimensions.....	7
Chapter 5. Block Diagram	8
Chapter 6. User Circuitry.....	9
6.1. Switches	9
6.2. LEDs.....	9
6.3. Potentiometer.....	9
6.4. Serial port	9
6.5. Debug LCD Module.....	10
6.6. Option Links	11
6.7. Oscillator Sources.....	13
6.8. Reset Circuit.....	13
6.9. LCD Controller Interface	13
Chapter 7. Modes.....	14
7.1. Boot mode.....	14
7.2. User mode	14
Chapter 8. Programming Methods.....	15
Chapter 9. Headers	16
9.1. Microcontroller Headers	16
9.2. Application Headers.....	18
Chapter 10. Code Development.....	21
10.1. Overview	21
10.2. Mode Support.....	21
10.3. Breakpoint Support.....	21
10.4. Memory Map	22
Chapter 11. Component Placement	23
Chapter 12. Additional Information	24

Chapter 1. Preface

Cautions

This document may be, wholly or partially, subject to change without notice.

All rights reserved. Duplication of this document, either in whole or part is prohibited without the written permission of Renesas Technology Europe Limited.

Trademarks

All brand or product names used in this manual are trademarks or registered trademarks of their respective companies or organisations.

Copyright

© Renesas Technology Europe Ltd. 2007. All rights reserved.

© Renesas Technology Corporation. 2007. All rights reserved.

© Renesas Solutions Corporation. 2007 All rights reserved.

Website: <http://www.renesas.eu>

Glossary

CPU	Central Processing Unit	RTE	Renesas Technology Europe Ltd.
HEW	High-performance Embedded Workshop	RSO	Renesas Solutions Organisation.
LED	Light Emitting Diode	RSK	Renesas Starter Kit
PC	Program Counter		

Chapter 2. Purpose

This RSK is an evaluation tool for Renesas microcontrollers.

Features include:

- Renesas Microcontroller Programming.
- User Code Debugging.
- User Circuitry such as Switches, LEDs and potentiometer(s).
- User or Example Application.
- Sample peripheral device initialisation code.

The RSK board contains all the circuitry required for microcontroller operation.

Chapter 3. Power Supply

3.1. Requirements

This RSK operates from a 5V power supply.

A diode provides reverse polarity protection only if a current limiting power supply is used.

All RSK boards are supplied with an E8a debugger. This product is able to power the RSK board with up to 300mA. When the RSK is connected to another system then that system should supply power to the RSK.

All RSK boards have an optional centre positive supply connector using a 2.1mm barrel power jack.

Warning

The RSK is neither under nor over voltage protected. Use a centre positive supply for this board.

3.2. Power – Up Behaviour

When the RSK is purchased the RSK board has the 'Release' or stand alone code from the example tutorial code pre-programmed into the Renesas microcontroller. On powering up the board the user LEDs will start to flash. After 200 flashes, or after pressing a switch the LEDs will flash at a rate controlled by the potentiometer.

Chapter 4. Board Layout

4.1. Component Layout

The following diagram shows top layer component layout of the board.

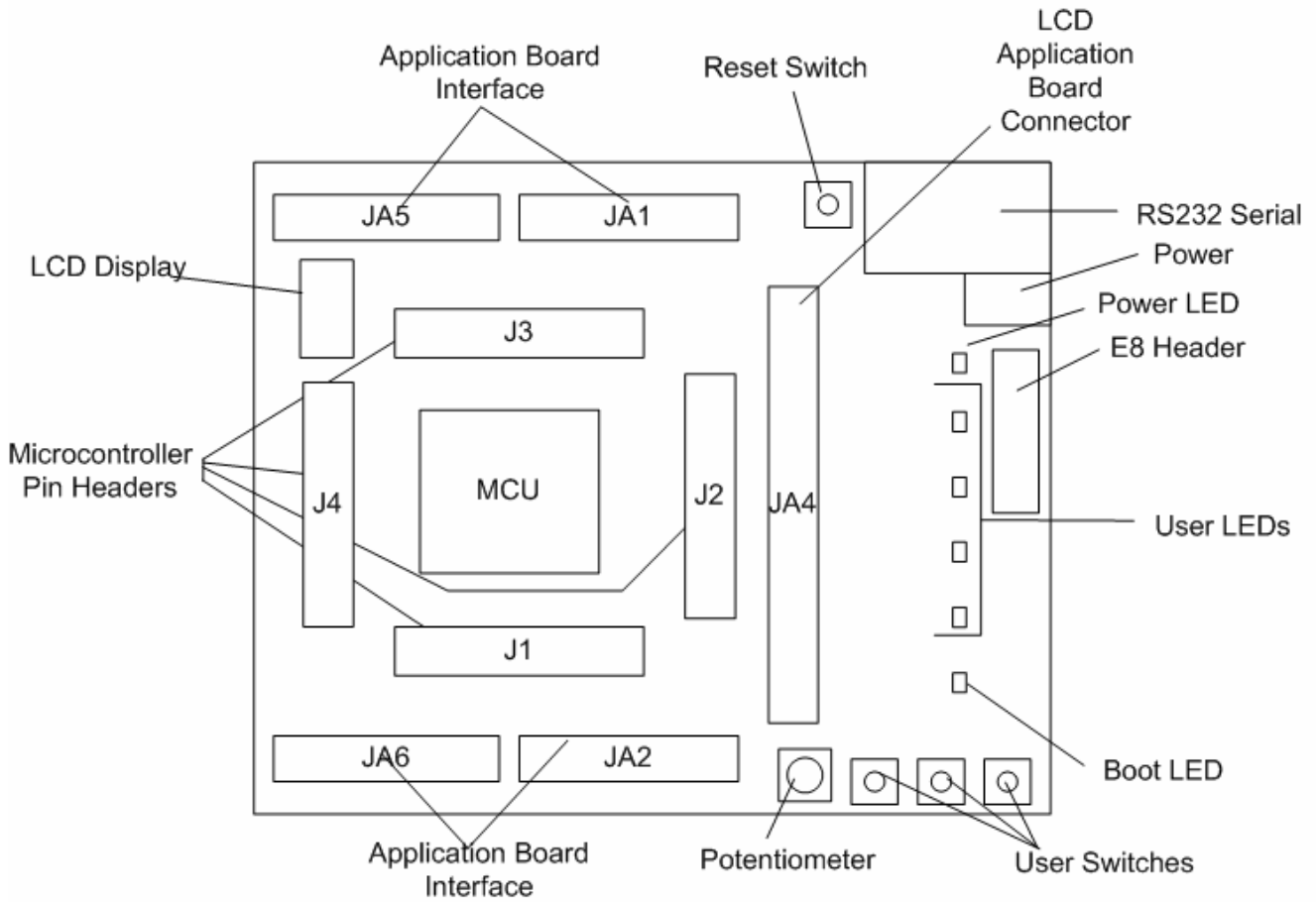

Figure 4-1: Board Layout

4.2. Board Dimensions

The following diagram gives the board dimensions and connector positions. All through hole connectors are on a common 0.1" grid for easy interfacing.

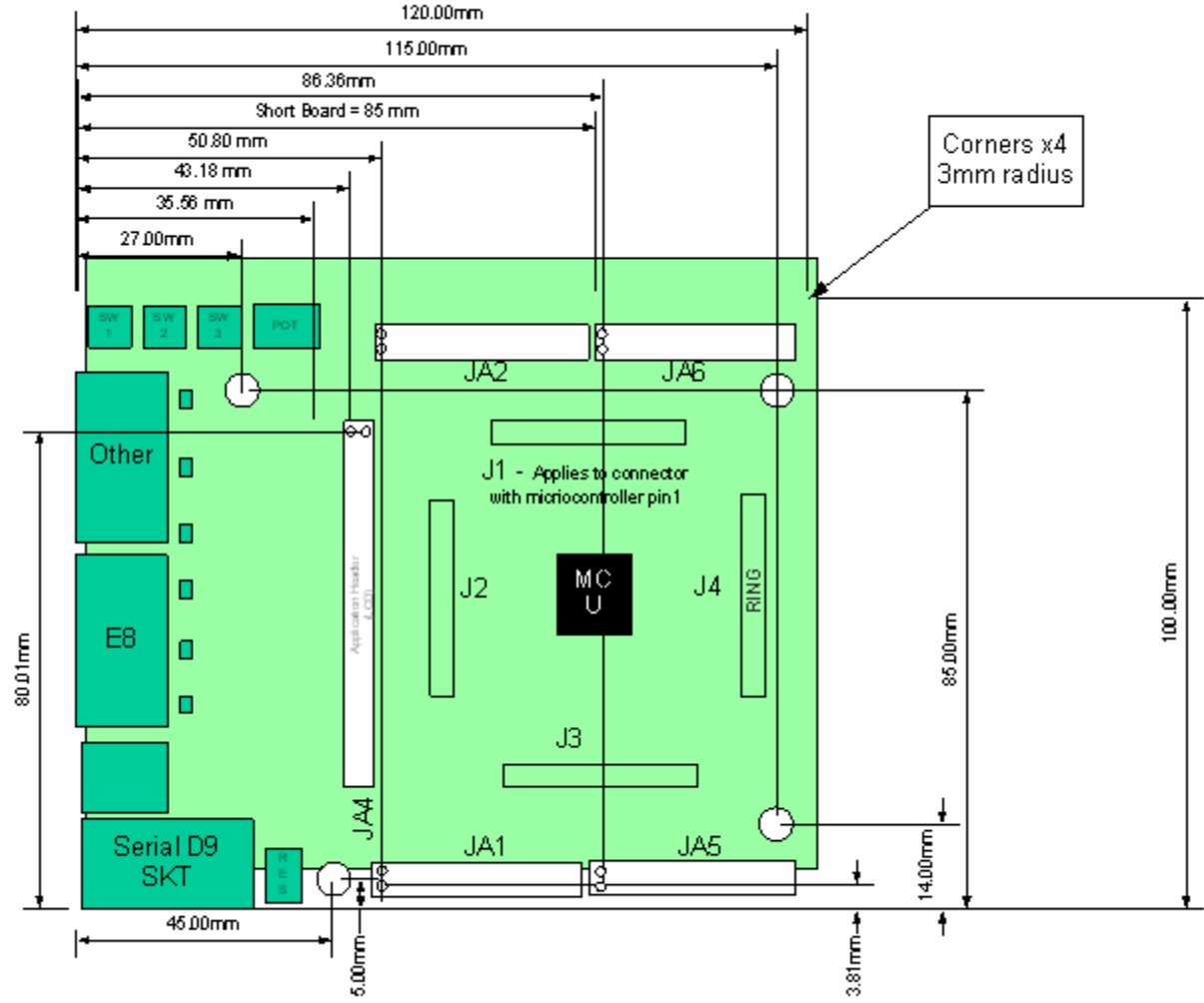

Figure 4-2 : Board Dimensions

Chapter 5. Block Diagram

Figure 5-1 shows the CPU board components and their connectivity.

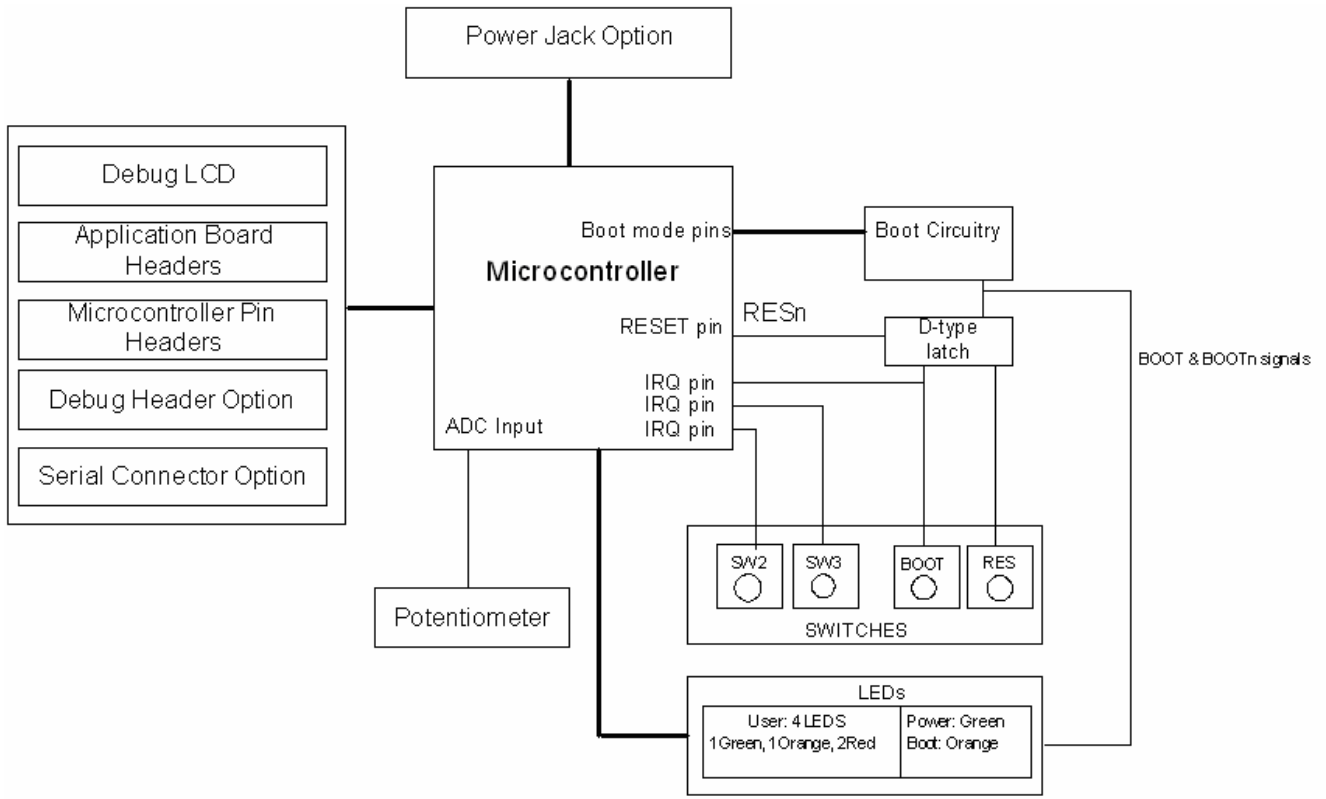

Figure 5-1: Block Diagram

Figure 5-2 shows the connections to the RSK.

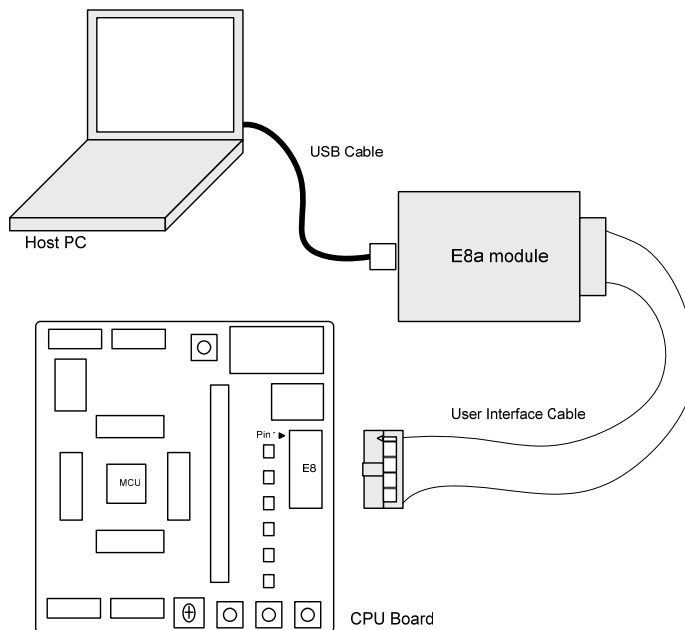

Figure 5-2 : RSK Connections

Chapter 6. User Circuitry

6.1. Switches

There are four switches located on the CPU board. The function of each switch and its connection are shown in Table 6-1.

Switch	Function	Microcontroller
RES	When pressed, the RSK microcontroller is reset.	RESn, Pin15
SW1/BOOT*	Connects to an IRQ input for user controls. The switch is also used in conjunction with the RES switch to place the device in BOOT mode when not using the E8a debugger.	IRQ0n, Pin 86 (Port 4, pin 3)
SW2*	Connects to an IRQ line for user controls.	IRQ1n, Pin 6 (Port 1, pin 5)
SW3*	Connects to the ADC trigger input. Option link allows connection to IRQ line. The option is a pair of OR links. For more details on option links, please refer to Sec 6.6.	IRQ4n_ADTRG, Pin 5 (Port 1, pin 4)

Table 6-1: Switch Functions

*Refer to schematic for detailed connectivity information.

6.2. LEDs

There are six LEDs on the RSK board. The green 'POWER' LED lights when the board is powered. The orange BOOT LED indicates the device is in BOOT mode when lit. The four user LEDs are connected to an IO port and will light when their corresponding port pin is set low.

Table 6-2, below, shows the LED pin references and their corresponding microcontroller port pin connections.

LED Reference (As shown on silkscreen)	Colour	Microcontroller Port Pin function	Microcontroller Pin Number
LED0	Green	Port 1.0	1
LED1	Orange	Port 1.1	2
LED2	Red	Port 1.6	7
LED3	Red	Port 3.1	25

Table 6-2: LED Port

6.3. Potentiometer

A single turn potentiometer is connected to AN8 (PC.0) of the microcontroller. This may be used to vary the input analogue voltage value to this pin between AVCC and Ground.

6.4. Serial port

The on-chip emulator port is connected to the E8a connector. Serial port SCI3_2 can optionally be connected to the E8 connector by fitting option resistors. The connections to be fitted are listed in the table 6-3.

Description	Function	Fit For E8a	Remove for E8a	Fit for RS232	Remove for RS232
TxD1	Programming Serial Port	R29	R14	R14	R29
RxD1	Programming Serial Port	R36	R19	R19	R36
CLK1	Programming Serial Port	R24	NA	NA	NA

Table 6-3: Serial Port settings

Secondary and tertiary microcontroller serial ports are connected to the application headers.

6.5. Debug LCD Module

A debug LCD module is supplied to be connected to the connector J10. This should be fitted so that the debug LCD module lies over J3. Care should be taken to ensure the pins are inserted correctly into J10. The debug LCD module uses a 4 bit interface to reduce the pin allocation. No contrast control is provided; this is set by a resistor on the supplied display module. The module supplied with the RSK only supports 5V operation.

Table 6-4 shows the pin allocation and signal names used on this connector.

J10					
Pin	Circuit Net Name	Device Pin	Pin	Circuit Net Name	Device Pin
1	Ground	-	2	5V Only	-
3	No Connection	-	4	DLCDRS	26
5	R/W (Wired to Write only)	-	6	DLCDE	27
7	No Connection	-	8	No connection	-
9	No Connection	-	10	No connection	-
11	DLCD4	28	12	DLCD5	29
13	DLCD6	30	14	DLCD7	31

Table 6-4 Debug LCD Module Connections

6.6. Option Links

Table 6-5 below describes the function of the option links contained on this RSK board.

Option Link Settings				
Reference	Function	Fitted	Alternative (Removed)	Related To
R1	Power Supply (External 3V3)	Connects CON_3V3 (external 3.3V) to Board_VCC	CON_3V disconnected from Board_VCC	R2
R2	Power Supply (External 5V)	Connects CON_5V (external 5V) to Board_VCC	CON_5V disconnected from Board_VCC	R1
R4	Serial Connector	Connects Alternate serial (CH2) to D connector	Disconnects Alternate serial from D connector.	R5, R7, R12
R5	Serial Connector	Connects Alternate serial (CH2) to D connector	Disconnects Alternate serial from D connector.	R4, R7, R12
R7	Alternate Serial	Connects Alternate Serial (CH2 - SC1b) to RS232 Transceiver	Should be removed if SC1b not used for RS232.	R4, R5, R12
R9	RS232 Serial	Disables RS232 Serial Transceiver	Enables RS232 Serial Transceiver	
R11	Power Supply	Connects J5 to Board_VCC	J5 disconnected from Board_VCC	
R12	Alternate Serial	Connects Alternate Serial (CH2 - SC1b) to RS232 Transceiver	Should be removed if SC1b not used for RS232.	R4, R5, R7
R14	RS232 Serial on SC1a CH0	Connects Serial Channel 0 to RS232 Transceiver	MUST be removed if R15 or R17 fitted.	R15, R17, R18, R19, R20
R15	RS232 Serial on Application Header	Connects Application Header to RS232 Transceiver	MUST be removed if R14 or R17 fitted.	R14, R17, R18, R19, R20
R17	Programming Serial Port	Connects RS232 port to Programming SCL port	MUST be removed if R36, R19 or R20 fitted.	R14, R15, R18, R19, R20
R18	Programming Serial Port	Connects RS232 port to Programming SCL port	MUST be removed if R29, R14 or R15 fitted.	R14, R15, R17, R19, R20
R19	RS232 Serial on SC1a CH0	Connects Serial Channel 0 to RS232 Transceiver	MUST be removed if R18 or R20 fitted.	R14, R15, R17, R18, R20
R20	RS232 Serial on Application Header	Connects Application Header to RS232 Transceiver	MUST be removed if R18 or R19 fitted.	R14, R15, R17, R18, R19
R23	E8	Connects PTCK pin to Ground	Disconnects PTCK pin from Ground.	R24
R24	Programming Serial Port	Connects E8a to Programming Serial port.	Should be removed if R23 fitted.	R23
R28	MCU Power Supply	Supply to MCU	Fit Low ohm resistor to measure current	
R29	Programming Serial Port	Connects E8a to Programming Serial port.	Should be removed if R17 fitted.	R17, R14, R15

Option Link Settings				
Reference	Function	Fitted	Alternative (Removed)	Related To
R36	Programming Serial Port	Connects E8a to Programming Serial port.	Should be removed if R18 fitted.	R18, R19, R20
R40	E8	Enables E8a		
R41	LCD Panel	Connects V2 to V3	Disconnects V2 from V3.	
R42	E8	Enables E8a		
R43	Oscillator	Connects external clock to MCU	Connects X2 to MCU	R44, R50, R51
R44	Oscillator	Connects external clock to MCU	Connects X2 to MCU	R43, R50, R51
R45	Application Board Interface	Use DLCD5 of application board interface	Use SC1bTX of application board interface	R53
R46	Oscillator	Connects X1 to MCU	Connects external clock to MCU	R48, R62, R63
R47	Oscillator	Load register connected	Load register disconnected	
R48	Oscillator	Connects X1 to MCU	Connects external clock to MCU	R46, R62, R63
R50	Oscillator	Connects X2 to MCU	Connects external clock to MCU	R43, R44, R51
R51	Oscillator	Connects X2 to MCU	Connects external clock to MCU	R43, R44, R50
R52	Power Supply	Connects CVCC pin to microcontroller supply pin UC_VCC.	Disconnects CVCC pin to microcontroller supply pin UC_VCC.	
R53	Application Board Interface	Use SC1bTX of application board interface	Use DLCD5 of application board interface	R45
R55	Application Board Interface	Use SC1bRX of application board interface	Use DLCD4 of application board interface	R56
R56	Application Board Interface	Use DLCD4 of application board interface	Use SC1bRX of application board interface	R55
R57	Application Board Interface	Use SC1bCK of application board interface	Use DLCDE of application board interface	R59
R59	Application Board Interface	Use DLCDE of application board interface	Use SC1bCK of application board interface	R57
R61	Power Supply	Connects AVCC to Board_VCC	Disconnects AVCC from Board_VCC	
R62	Oscillator	Connects external clock to MCU	Connects X1 to MCU	R46, R48, R63
R63	Oscillator	Connects external clock to MCU	Connects X1 to MCU	R46, R48, R62
R65	Power Supply	Connects AVSS to Ground	Disconnects AVSS from Ground	
R66	External Analog voltage supply	Connects AVCC to external AVCC pin CON_AVCC	Disconnects AVCC from external AVCC pin CON_AVCC	
R69	Application Board Interface	Use IRQ4n of application board interface	Use ADTRG of application board interface	R71

Option Link Settings				
Reference	Function	Fitted	Alternative (Removed)	Related To
R71	Application Board Interface	Use ADTRG of application board interface	Use IRQ4n of application board interface	R69

Table 6-5: Option Links

6.7. Oscillator Sources

A crystal oscillator is fitted on the RSK and used to supply the main clock input to the Renesas microcontroller. Table 6-6 details the oscillators that are fitted and alternative footprints provided on this RSK:

Component		
Crystal (X1)	Fitted	32.768 KHz (90SMX package)
Crystal (X2)	Fitted	16 MHz (HC49/4H package)

Table 6-6: Oscillators / Resonators

6.8. Reset Circuit

The CPU Board includes a simple latch circuit that links the mode selection and reset circuit. This provides an easy method for swapping the device between Boot Mode and User mode. This circuit is not required on customer's boards as it is intended for providing easy evaluation of the operating modes of the device on the RSK. Please refer to the hardware manual for more information on the requirements of the reset circuit.

The Reset circuit operates by latching the state of the boot switch on pressing the reset button. This control is subsequently used to modify the port pin P24 states as required.

The port pin P24 must change state only while the reset signal is active to avoid possible device damage.

The reset is held in the active state for a fixed period by a pair of resistors and a capacitor. Please check the reset requirements carefully to ensure the reset circuit on the user's board meets all the reset timing requirements.

6.9. LCD Controller Interface

This RSK should be soldered on top of the LCD application board in JA1, JA2, JA5, JA6 and JA4 positions. These application headers are detailed in section 9.2 in this user manual.

For more details on LCD application board please refer to LCD application board user manual.

Chapter 7. Modes

This RSK supports Boot mode and User mode.

Details of programming the FLASH memory is described in the H8/38347 Group Hardware Manual.

7.1. Boot mode

The boot mode settings for this RSK are shown in Table 7-1: Boot Mode pin settings below:

P24	P26	LSI State after Reset End
Low	High	Boot Mode

Table 7-1: Boot Mode pin settings

The software supplied with this RSK supports Boot mode using an E8a and HEW only. However, hardware exists to enter boot mode manually, do not connect the E8a in this case. Press and hold the SW1/BOOT. The port pin P24 is held in its boot state while reset is pressed and released. Release the boot button. The BOOT LED will be illuminated to indicate that the microcontroller is in boot mode.

When neither the E8a is connected nor the board is placed in boot mode as above, the port pin P24 is pulled high by a 100k resistor.

When an E8a is used the port pin P24 and P26 are controlled by the E8a.

7.2. User mode

Because the port pin P24 is pulled high, this RSK will always boot in User mode when the E8a is not connected and the boot switch is not depressed. Refer to H8/38347 Group Hardware Manual for details of User mode. The user mode settings for this RSK are shown in Table 7-1: Boot Mode pin settings below:

P24	P26	LSI State after Reset End
High	X	User Mode

X: Don't care

Table 7-2: User Mode pin settings

Chapter 8. Programming Methods

The board is intended for use with HEW and the supplied E8a debugger. Refer to H8/38347 Group Hardware Manual for details of programming the microcontroller without using these tools.

Chapter 9. Headers

9.1. Microcontroller Headers

Table 9-1 to Table 9-4 show the microcontroller pin headers and their corresponding microcontroller connections. The header pins connect directly to the microcontroller pin unless otherwise stated.

J1					
Pin	Circuit Net Name	Device Pin	Pin	Circuit Net Name	Device Pin
1	LED0	1	2	LED1	2
3	TMR0	3	4	TRIGb	4
5	IRQ4n_ADTRG*	5	6	IRQ1n	6
7	LED2_IRQ2n	7	8	TRIGa	8
9	CON_X1	9	10	CON_X2	10
11	GROUND	11	12	CON_OSC2	12
13	CON_OSC1	13	14	TEST	14
15	RESn	15	16	SClCk	16
17	SClCRX	17	18	SClCTX	18
19	IO_0	19	20	E8_P24	20
21	PTCK	21	22	PTRX	22
23	PTTX	23	24	TMR1	24

Table 9-1: J1

J2					
Pin	Circuit Net Name	Device Pin	Pin	Circuit Net Name	Device Pin
1	LED3	25	2	DLCDRS	26
3	DLCDE_SClbCK*	27	4	DLCD4_SClbRX*	28
5	DLCD5_SClbTX*	29	6	DLCD6	30
7	DLCD7	31	8	CVCC	32
9	GROUND	33	10	V3	34
11	V2	35	12	V1	36
13	V0	37	14	UC_VCC	38
15	COM4	39	16	COM3	40
17	COM2	41	18	COM1	42
19	SEG1	43	20	SEG2	44
21	SEG3	45	22	SEG4	46
23	SEG5	47	24	SEG6	48
25	SEG7	49	26	SEG8	50

Table 9-2: J2

J3					
Pin	Circuit Net Name	Device Pin	Pin	Circuit Net Name	Device Pin
1	SEG9	51	2	SEG10	52
3	SEG11	53	4	SEG12	54
5	SEG13	55	6	SEG14	56
7	SEG15	57	8	SEG16	58
9	SEG17	59	10	SEG18	60
11	SEG19	61	12	SEG20	62
13	SEG21	63	14	SEG22	64
15	SEG23	65	16	SEG24	66
17	SEG25	67	18	SEG26	68
19	SEG27	69	20	SEG28	70
21	SEG29	71	22	SEG30	72
23	SEG31	73	24	SEG32	74

Table 9-3: J3

J4					
Pin	Circuit Net Name	Device Pin	Pin	Circuit Net Name	Device Pin
1	SEG33	75	2	SEG34	76
3	SEG35	77	4	SEG36	78
5	SEG37	79	6	SEG38	80
7	SEG39	81	8	SEG40	82
9	SClACK	83	10	SClARX	84
11	SClATX	85	12	IRQ0N	86
13	CON_AVCC	87	14	AD0	88
15	AD1	89	16	AD2	90
17	AD3	91	18	AD4	92
19	AD5	93	20	AD6	94
21	AD7	95	22	AD_POT	96
23	PIN97	97	24	PIN98	98
25	PIN99	99	26	AVss	100

Table 9-4: J4

9.2. Application Headers

Table 9-5 and Table 9-6 below show the standard application header connections.

JA1									
Pin	Generic Header Name		CPU board Signal Name	Device Pin	Pin	Header Name		CPU board Signal Name	Device Pin
1	Regulated Supply 1		5V	-	2	Regulated Supply 1		GROUND	-
3	Regulated Supply 2		3V3	-	4	Regulated Supply 2		GROUND	-
5	Analogue Supply		AVcc	87	6	Analogue Supply		AVss	-
7	Analogue Reference		AVref	-	8	ADTRG		ADTRG*	5
9	ADC0	I0	AD0	88	10	ADC1	I1	AD1	89
11	ADC2	I2	AD2	90	12	ADC3	I3	AD3	91
13	DAC0		DAC0	-	14	DAC1		DAC1	-
15	IOPort		IO_0	19	16	IOPort		IO_1	-
17	IOPort		IO_2	-	18	IOPort		IO_3	-
19	IOPort		IO_4	-	20	IOPort		IO_5	-
21	IOPort		IO_6	-	22	IOPort		IO_7	-
23	Open drain	IRQAEC	IRQ3	7	24	I ² C Bus - (3rd pin)		IIC_EX	-
25	I ² C Bus		IIC_SDA	-	26	I ² C Bus		IIC_SCL	-

Table 9-5: JA1 Standard Generic Header

JA2									
Pin	Generic Header Name		CPU board Signal Name	Device Pin	Pin	Header Name		CPU board Signal Name	Device Pin
1	Open drain		RESn	15	2	External Clock Input		EXTAL	13
3	Open drain		NMIIn	-	4	Regulated Supply 1		GND	-
5	Open drain output		WDT_OVF	-	6	Serial Port		SCIaTX*	85
7	Open drain	WUP	IRQ0	86	8	Serial Port		SCIaRX*	84
9	Open drain		IRQ1	6	10	Serial Port		SCIaCK	83
11	Up/down		MO_UD	-	12	Serial Port Handshake		CTS/RTS	-
13	Motor control		MO_Up	-	14	Motor control		MO_Un	-
15	Motor control		MO_Vp	-	16	Motor control		MO_Vn	-
17	Motor control		MO_Wp	-	18	Motor control		MO_Wn	-
19	Output		TMR0	3	20	Output		TMR1	24
21	Input		TRIGa	8	22	Input		TRIGb	4
23	Open drain		IRQ2*	5	24	Tristate Control		TRSTn	-
25	SPARE		-	-	26	SPARE		-	-

Table 9-6: JA2 Standard Generic Header

Table 9-7 below show the LCD application header connections. The LCD application board need to be mounted on RSKH838347 board in order to make use of the LCD panel. The following header (i.e. header JA4) will be connected to JA4B header on LCD application board.

JA4							
Pin	Generic Header Name	CPU board Signal Name	Device Pin	Pin	Header Name	CPU board Signal Name	Device Pin
1	V0	V0	37	2	V1	V1	36
3	V2	V2	35	4	V3	V3	34
5	GROUND	GROUND	-	6	GROUND	GROUND	-
7	COM1	COM1	42	8	COM2	COM2	41
9	COM3	COM3	40	10	COM4	COM4	39
11	SEG1	SEG1	43	12	SEG2	SEG2	44
13	SEG3	SEG3	45	14	SEG4	SEG4	46
15	SEG5	SEG5	47	16	SEG6	SEG6	48
17	SEG7	SEG7	49	18	SEG8	SEG8	50
19	SEG9	SEG9	51	20	SEG10	SEG10	52
21	SEG11	SEG11	53	22	SEG12	SEG12	54
23	SEG13	SEG13	55	24	SEG14	SEG14	56
25	SEG15	SEG15	57	26	SEG16	SEG16	58
27	SEG17	SEG17	59	28	SEG18	SEG18	60
29	SEG19	SEG19	61	30	SEG20	SEG20	62
31	SEG21	SEG21	63	32	SEG22	SEG22	64
33	SEG23	SEG23	65	34	SEG24	SEG24	66
35	SEG25	SEG25	67	36	SEG26	SEG26	68
37	SEG27	SEG27	69	38	SEG28	SEG28	70
39	SEG29	SEG29	71	40	SEG30	SEG30	72
41	SEG31	SEG31	73	42	SEG32	SEG32	74
43	SEG33	SEG33	75	44	SEG34	SEG34	76
45	SEG35	SEG35	77	46	SEG36	SEG36	78
47	SEG37	SEG37	79	48	SEG38	SEG38	80
49	SEG39	SEG39	81	50	SEG40	SEG40	82

Table 9-7: JA4 Optional Generic Header

Table 9-8 and Table 9-9 below show the optional generic header connections.

JA5									
Pin	Generic Header Name		CPU board Signal Name	Device Pin	Pin	Header Name		CPU board Signal Name	Device Pin
1	ADC4	I4	AD4	92	2	ADC5	I5	AD5	93
3	ADC6	I6	AD6	94	4	ADC7	I7	AD7	95
5	CAN		CAN1TX	---	6	CAN		CAN1RX	---
7	CAN		CAN2TX	---	8	CAN		CAN2RX	---
9	Reserved				10	Reserved			
11	Reserved				12	Reserved			
13	Reserved				14	Reserved			
15	Reserved				16	Reserved			
17	Reserved				18	Reserved			
19	Reserved				20	Reserved			
21	Reserved				22	Reserved			
23	Reserved				24	Reserved			

Table 9-8: JA5 Optional Generic Header

JA6									
Pin	Generic Header Name		CPU board Signal Name	Device Pin	Pin	Header Name		CPU board Signal Name	Device Pin
1	DMA		DREQ	---	2	DMA		DACK	---
3	DMA		TEND	---	4	Standby (Open drain)		STBYn	---
5	Host Serial	SCIdTX	RS232TX	---	6	Host Serial	SCIdRX	RS232RX	---
7	Serial Port		SClBRX	28	8	Serial Port		SClBTX*	29
9	Serial Port	Synchronous	SClCTX	18	10	Serial Port		SClBCK*	27
11	Serial Port	Synchronous	SClCCK	16	12	Serial Port	Synchronous	SClCRX*	17
13	Reserved				14	Reserved			
15	Reserved				16	Reserved			
17	Reserved				18	Reserved			
19	Reserved				20	Reserved			
21	Reserved				22	Reserved			
23	Reserved				24	Reserved			
25	Reserved				26	Reserved			

Table 9-9: JA6 Optional Generic Header

* Marked pins are affected by option links.

Chapter 10. Code Development

10.1. Overview

Note: For all code debugging using Renesas software tools, the RSK board must be connected to a PC USB port via an E8a. An E8a is supplied with the RSK product.

10.2. Mode Support

HEW connects to the Microcontroller and programs it via the E8a. Mode support is handled transparently to the user.

10.3. Breakpoint Support

HEW supports breakpoints on the user code, both in RAM and ROM.

Double clicking in the breakpoint column in the code sets the breakpoint. Breakpoints will remain unless they are double clicked to remove them.

10.4. Memory Map

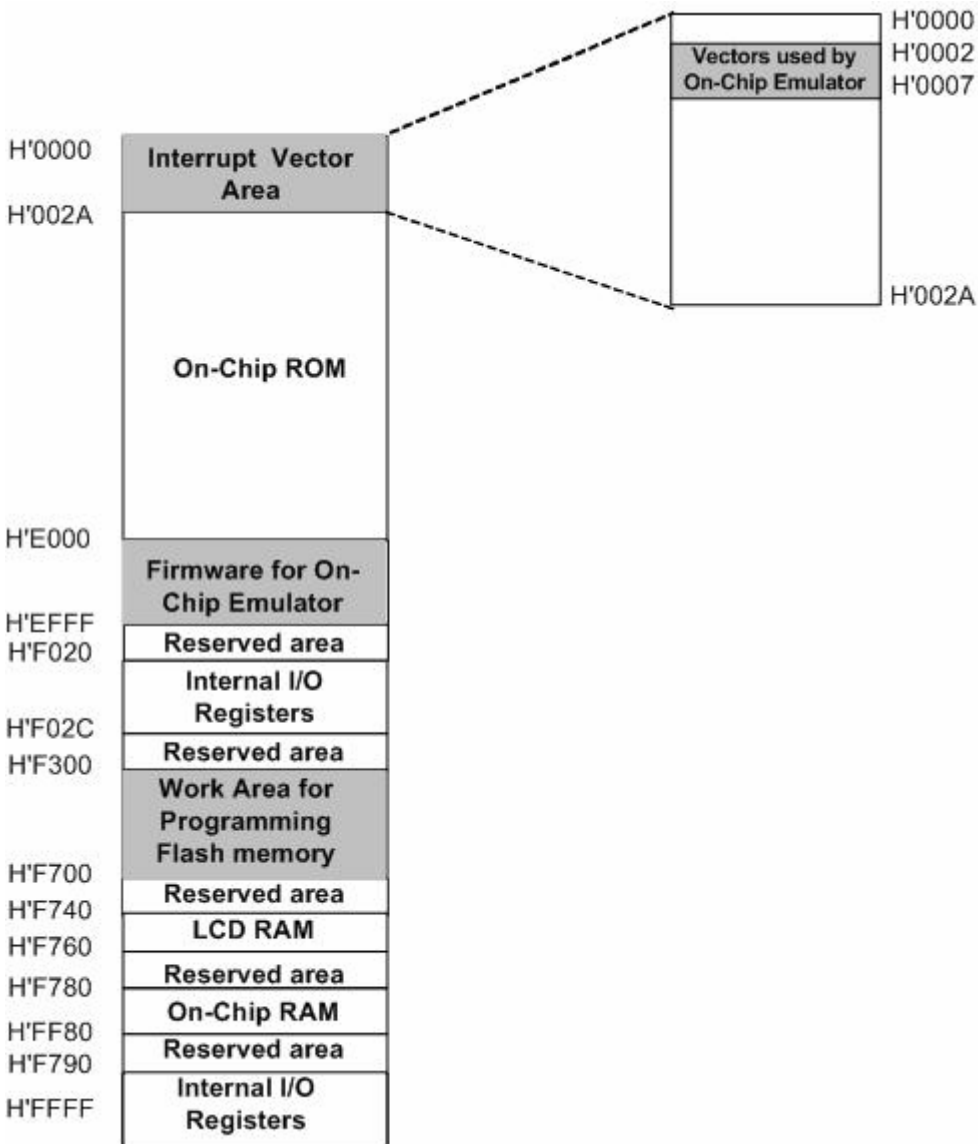

Figure 10-1: Memory Map

Chapter 11. Component Placement

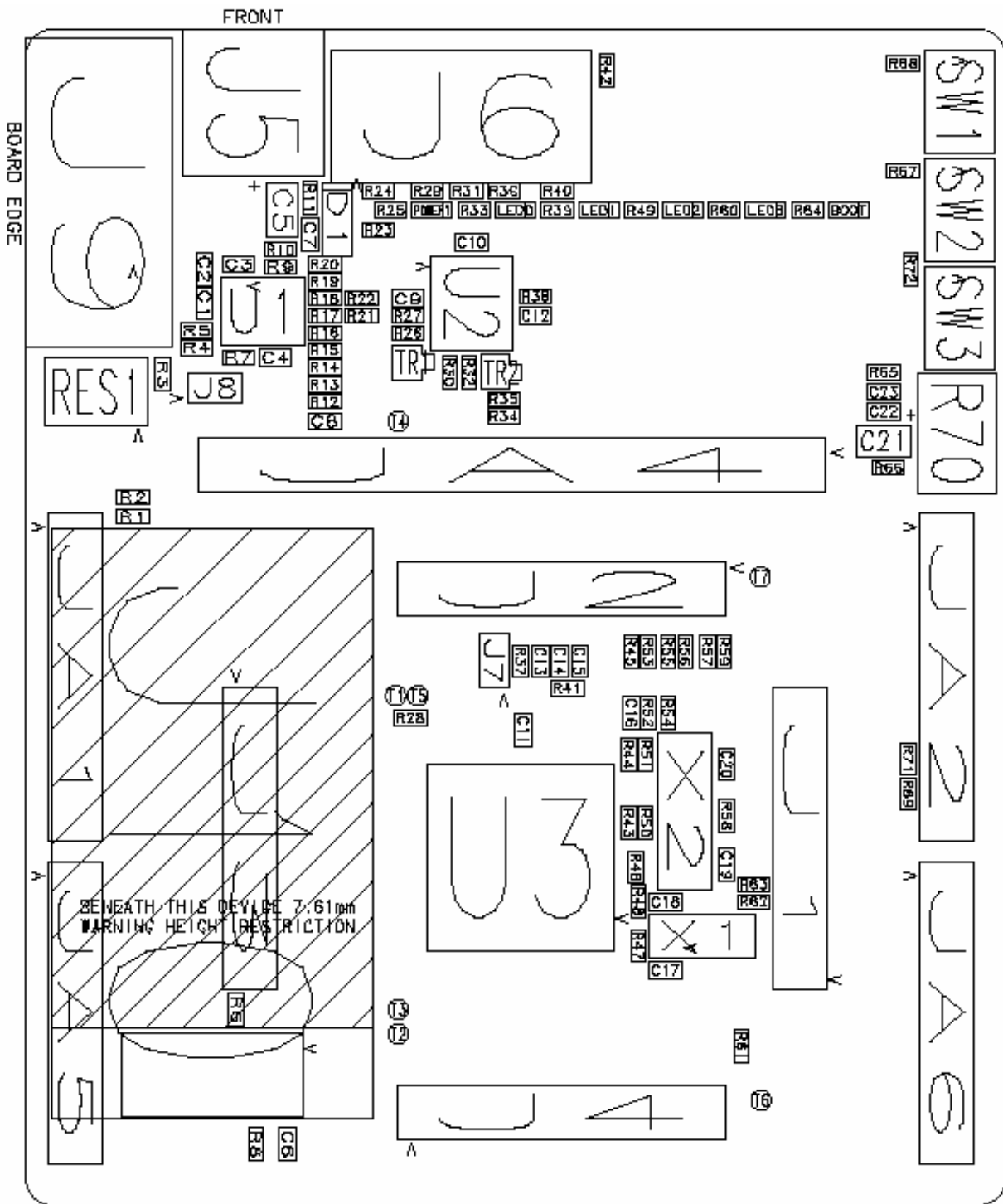

Figure 11-1: Component Placement

Chapter 12. Additional Information

For details on how to use High-performance Embedded Workshop (HEW, refer to the HEW manual available on the CD or from the web site.

For information about the H8/38347 series microcontrollers refer to the H8/3847R Group, H8/3847S Group, H8/38347 Group, H8/38447 Group hardware manual.

For information about the H8/38347 assembly language, refer to the H8/300L Series Software Manual.

Online technical support and information is available at: http://www.renesas.com/renesas_starter_kits

Technical Contact Details

America: techsupport.rta@renesas.com

Europe: tools.support.eu@renesas.com

Japan: csc@renesas.com

General information on Renesas Microcontrollers can be found on the Renesas website at: <http://www.renesas.com/>

Renesas Starter Kit for H8/38347

User's Manual

Publication Date Rev.2.00 15.OCT.2006

Published by: Renesas Technology Europe Ltd.

Duke's Meadow, Millboard Road, Bourne End

Buckinghamshire SL8 5FH, United Kingdom

©2007 Renesas Technology Europe and Renesas Solutions Corp., All Rights Reserved.

Renesas Starter Kit for H8/38347 User's Manual



Renesas Electronics Corporation

1753, Shimonumabe, Nakahara-ku, Kawasaki-shi, Kanagawa 211-8668 Japan

REG10J0014-0200