

To our customers,

Old Company Name in Catalogs and Other Documents

On April 1st, 2010, NEC Electronics Corporation merged with Renesas Technology Corporation, and Renesas Electronics Corporation took over all the business of both companies. Therefore, although the old company name remains in this document, it is a valid Renesas Electronics document. We appreciate your understanding.

Renesas Electronics website: <http://www.renesas.com>

April 1st, 2010
Renesas Electronics Corporation

Issued by: Renesas Electronics Corporation (<http://www.renesas.com>)

Send any inquiries to <http://www.renesas.com/inquiry>.

Notice

1. All information included in this document is current as of the date this document is issued. Such information, however, is subject to change without any prior notice. Before purchasing or using any Renesas Electronics products listed herein, please confirm the latest product information with a Renesas Electronics sales office. Also, please pay regular and careful attention to additional and different information to be disclosed by Renesas Electronics such as that disclosed through our website.
2. Renesas Electronics does not assume any liability for infringement of patents, copyrights, or other intellectual property rights of third parties by or arising from the use of Renesas Electronics products or technical information described in this document. No license, express, implied or otherwise, is granted hereby under any patents, copyrights or other intellectual property rights of Renesas Electronics or others.
3. You should not alter, modify, copy, or otherwise misappropriate any Renesas Electronics product, whether in whole or in part.
4. Descriptions of circuits, software and other related information in this document are provided only to illustrate the operation of semiconductor products and application examples. You are fully responsible for the incorporation of these circuits, software, and information in the design of your equipment. Renesas Electronics assumes no responsibility for any losses incurred by you or third parties arising from the use of these circuits, software, or information.
5. When exporting the products or technology described in this document, you should comply with the applicable export control laws and regulations and follow the procedures required by such laws and regulations. You should not use Renesas Electronics products or the technology described in this document for any purpose relating to military applications or use by the military, including but not limited to the development of weapons of mass destruction. Renesas Electronics products and technology may not be used for or incorporated into any products or systems whose manufacture, use, or sale is prohibited under any applicable domestic or foreign laws or regulations.
6. Renesas Electronics has used reasonable care in preparing the information included in this document, but Renesas Electronics does not warrant that such information is error free. Renesas Electronics assumes no liability whatsoever for any damages incurred by you resulting from errors in or omissions from the information included herein.
7. Renesas Electronics products are classified according to the following three quality grades: “Standard”, “High Quality”, and “Specific”. The recommended applications for each Renesas Electronics product depends on the product’s quality grade, as indicated below. You must check the quality grade of each Renesas Electronics product before using it in a particular application. You may not use any Renesas Electronics product for any application categorized as “Specific” without the prior written consent of Renesas Electronics. Further, you may not use any Renesas Electronics product for any application for which it is not intended without the prior written consent of Renesas Electronics. Renesas Electronics shall not be in any way liable for any damages or losses incurred by you or third parties arising from the use of any Renesas Electronics product for an application categorized as “Specific” or for which the product is not intended where you have failed to obtain the prior written consent of Renesas Electronics. The quality grade of each Renesas Electronics product is “Standard” unless otherwise expressly specified in a Renesas Electronics data sheets or data books, etc.
 - “Standard”: Computers; office equipment; communications equipment; test and measurement equipment; audio and visual equipment; home electronic appliances; machine tools; personal electronic equipment; and industrial robots.
 - “High Quality”: Transportation equipment (automobiles, trains, ships, etc.); traffic control systems; anti-disaster systems; anti-crime systems; safety equipment; and medical equipment not specifically designed for life support.
 - “Specific”: Aircraft; aerospace equipment; submersible repeaters; nuclear reactor control systems; medical equipment or systems for life support (e.g. artificial life support devices or systems), surgical implantations, or healthcare intervention (e.g. excision, etc.), and any other applications or purposes that pose a direct threat to human life.
8. You should use the Renesas Electronics products described in this document within the range specified by Renesas Electronics, especially with respect to the maximum rating, operating supply voltage range, movement power voltage range, heat radiation characteristics, installation and other product characteristics. Renesas Electronics shall have no liability for malfunctions or damages arising out of the use of Renesas Electronics products beyond such specified ranges.
9. Although Renesas Electronics endeavors to improve the quality and reliability of its products, semiconductor products have specific characteristics such as the occurrence of failure at a certain rate and malfunctions under certain use conditions. Further, Renesas Electronics products are not subject to radiation resistance design. Please be sure to implement safety measures to guard them against the possibility of physical injury, and injury or damage caused by fire in the event of the failure of a Renesas Electronics product, such as safety design for hardware and software including but not limited to redundancy, fire control and malfunction prevention, appropriate treatment for aging degradation or any other appropriate measures. Because the evaluation of microcomputer software alone is very difficult, please evaluate the safety of the final products or system manufactured by you.
10. Please contact a Renesas Electronics sales office for details as to environmental matters such as the environmental compatibility of each Renesas Electronics product. Please use Renesas Electronics products in compliance with all applicable laws and regulations that regulate the inclusion or use of controlled substances, including without limitation, the EU RoHS Directive. Renesas Electronics assumes no liability for damages or losses occurring as a result of your noncompliance with applicable laws and regulations.
11. This document may not be reproduced or duplicated, in any form, in whole or in part, without prior written consent of Renesas Electronics.
12. Please contact a Renesas Electronics sales office if you have any questions regarding the information contained in this document or Renesas Electronics products, or if you have any other inquiries.

(Note 1) “Renesas Electronics” as used in this document means Renesas Electronics Corporation and also includes its majority-owned subsidiaries.

(Note 2) “Renesas Electronics product(s)” means any product developed or manufactured by or for Renesas Electronics.

Renesas Starter Kit 2 for SH7286

User's Manual

RENEASAS SINGLE-CHIP MICROCOMPUTER
SuperH™ RISC engine

Disclaimer

By using this Renesas Starter Kit (RSK), the user accepts the following terms. The RSK is not guaranteed to be error free, and the entire risk as to the results and performance of the RSK is assumed by the User. The RSK is provided by Renesas on an "as is" basis without warranty of any kind whether express or implied, including but not limited to the implied warranties of satisfactory quality, fitness for a particular purpose, title and non-infringement of intellectual property rights with regard to the RSK. Renesas expressly disclaims all such warranties. Renesas or its affiliates shall in no event be liable for any loss of profit, loss of data, loss of contract, loss of business, damage to reputation or goodwill, any economic loss, any reprogramming or recall costs (whether the foregoing losses are direct or indirect) nor shall Renesas or its affiliates be liable for any other direct or indirect special, incidental or consequential damages arising out of or in relation to the use of this RSK, even if Renesas or its affiliates have been advised of the possibility of such damages.

Precautions

This Renesas Starter Kit is only intended for use in a laboratory environment under ambient temperature and humidity conditions. A safe separation distance should be used between this and any sensitive equipment. Its use outside the laboratory, classroom, study area or similar such area invalidates conformity with the protection requirements of the Electromagnetic Compatibility Directive and could lead to prosecution.

The product generates, uses, and can radiate radio frequency energy and may cause harmful interference to radio communications. However, there is no guarantee that interference will not occur in a particular installation. If this equipment causes harmful interference to radio or television reception, which can be determined by turning the equipment off or on, you are encouraged to try to correct the interference by one or more of the following measures;

- ensure attached cables do not lie across the equipment
- reorient the receiving antenna
- increase the distance between the equipment and the receiver
- connect the equipment into an outlet on a circuit different from that which the receiver is connected
- power down the equipment when not in use
- consult the dealer or an experienced radio/TV technician for help NOTE: It is recommended that wherever possible shielded interface cables are used.

The product is potentially susceptible to certain EMC phenomena. To mitigate against them it is recommended that the following measures be undertaken;

- The user is advised that mobile phones should not be used within 10m of the product when in use.
- The user is advised to take ESD precautions when handling the equipment.

The Renesas Starter Kit does not represent an ideal reference design for an end product and does not fulfil the regulatory standards for an end product.

Table of Contents

Chapter 1. Preface	1
Chapter 2. Purpose	2
Chapter 3. Power Supply	3
3.1. Requirements	3
3.2. Power-up Behaviour	3
Chapter 4. Board Layout	4
4.1. Component Layout	4
4.2. Board Dimensions	5
Chapter 5. Block Diagram	6
Chapter 6. User Circuitry	7
6.1. Switches	7
6.2. LEDs	7
6.3. Potentiometer	7
6.4. Serial port	8
6.5. LCD Module	8
6.6. USB Module	8
6.7. RCAN Module	9
6.8. Option Links	10
6.9. Oscillator Sources	15
6.10. Reset Circuit	15
Chapter 7. Modes	17
7.1. Boot mode	17
7.2. User Mode	17
Chapter 8. Programming Methods	18
Chapter 9. Headers	19
9.1. Microcontroller Headers	19
9.2. Application Headers	23
Chapter 10. Code Development	27
10.1. Overview	27
10.2. Compiler Restrictions	27
10.3. Breakpoint Support	27
10.4. Memory Map	28
Chapter 11. Component Placement	29
Chapter 12. Additional Information	30

Chapter 1. Preface

Cautions

This document may be, wholly or partially, subject to change without notice.

All rights reserved. No one is permitted to reproduce or duplicate, in any form, a part or this entire document without the written permission of Renesas Technology Europe Limited.

Trademarks

All brand or product names used in this manual are trademarks or registered trademarks of their respective companies or organisations.

Copyright

© Renesas Technology Europe Ltd. 2008. All rights reserved.

© Renesas Technology Corporation. 2008. All rights reserved.

© Renesas Solutions Corporation. 2008. All rights reserved.

Website: <http://www.renesas.com/>

Glossary

ADC	Analog to Digital Converter
DAC	Digital to Analog Converter
HEW	High-Performance Embedded Workbench
I/O	Input / Output
LCD	Liquid Crystal Display
LED	Light Emitting Diode
MCU	Microcontroller Unit
UART	Universal Asynchronous Receiver / Transmitter
USB	Universal Serial Bus

Chapter 2. Purpose

This RSK is an evaluation tool for Renesas microcontrollers.

Features include:

- Renesas Microcontroller Programming.
- User Code Debugging.
- User Circuitry such as switches, LEDs and potentiometer.
- Sample Application.
- Sample peripheral device initialisation code.

The MCU board contains all the circuitry required for microcontroller operation.

This manual describes the technical details of the RSK hardware. The Quick Start Guide and Tutorial Manual provide details of the software installation and debugging environment.

Chapter 3. Power Supply

3.1. Requirements

This MCU board operates from a 5V DC power supply (supplied).

A diode provides reverse polarity protection only if a current limiting power supply is used.

All MCU boards have an optional centre positive supply connector using a 2.1mm barrel power jack.

Warning

The MCU board is neither under nor over voltage protected. Use a centre positive supply for this board.

3.2. Power-up Behaviour

When the RSK is purchased the MCU board has the 'Release' or stand alone code from the example tutorial code pre-programmed into the Renesas microcontroller. On powering up the board the user LEDs will start to flash. Pressing any switch will cause the LEDs to flash at a rate controlled by the potentiometer.

4.2. Board Dimensions

The following diagram gives the board dimensions and connector positions. All through-hole connectors are on a common 0.1" grid for easy interfacing.

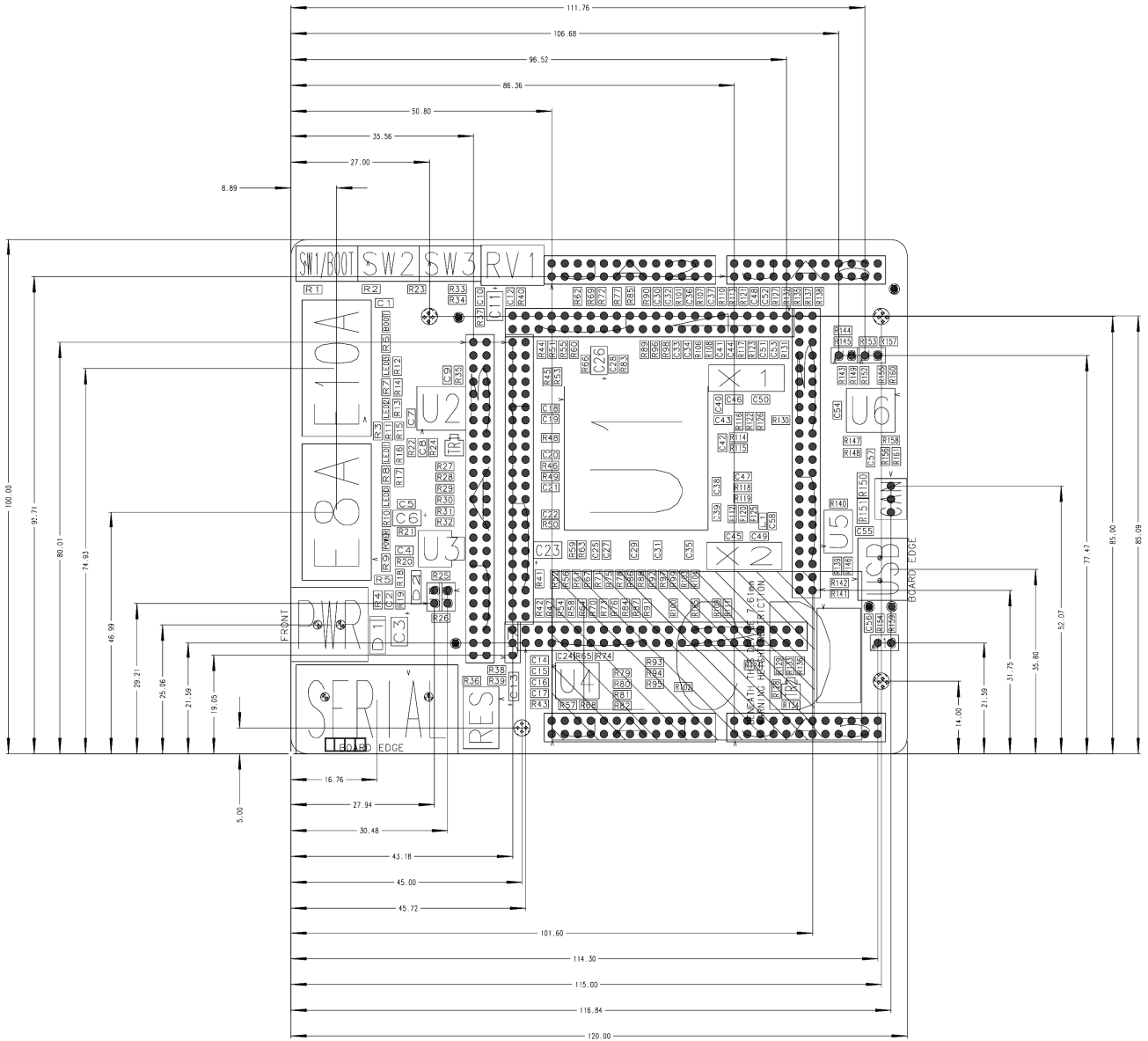

Figure 4-2 : Board Dimensions

Chapter 5. Block Diagram

Figure 5-1 shows the MCU board components and their connectivity.

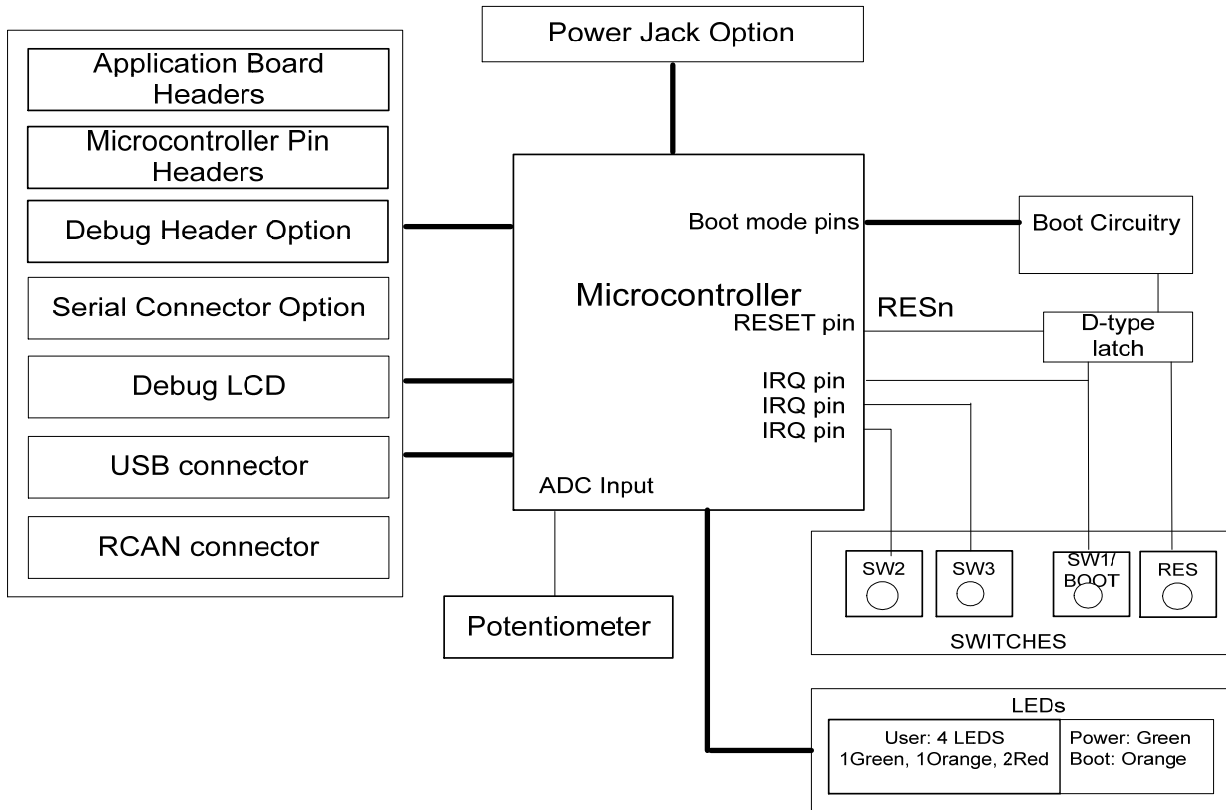

Figure 5-1: Block Diagram

Figure 5-2 shows the connections to the RSK.

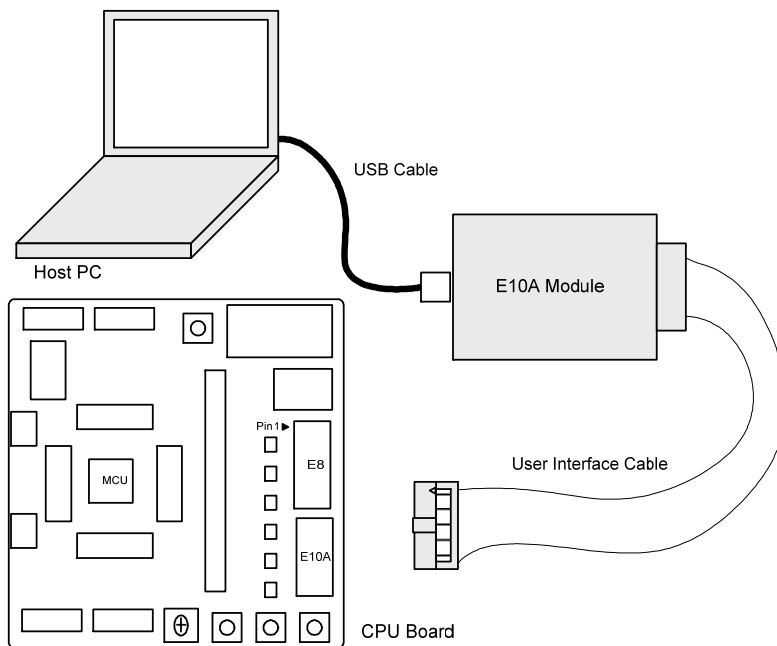

Figure 5-2 : RSK Connections

Chapter 6. User Circuitry

6.1. Switches

There are four switches located on the MCU board. The function of each switch and its connection are shown in **Table 6-1: Switch Functions**

Switch	Function	Microcontroller
RES	When pressed, the MCU board microcontroller is reset.	RESn, Pin 133
SW1/BOOT*	Connects to an IRQ input for user controls.	IRQ0, Pin 57 (Port D, bit 16)
SW2*	Connects to an IRQ line for user controls.	IRQ1, Pin 58 (Port D, bit 17)
SW3*	Connects to an IRQ line for user controls. The same switch may also function as an ADC trigger input.	IRQ2, Pin 59 (Port D, bit 18)

Table 6-1: Switch Functions

*Refer to the schematic for detailed connectivity information.

6.2. LEDs

There are six LEDs on the MCU board. The green 'POWER' LED lights when the board is powered. The orange BOOT LED indicates the device is in BOOT mode when lit. The four user LEDs are connected to an I/O port and will light when their corresponding port pin is set low.

The LED pin references and their corresponding microcontroller port pin connections are shown in **Table 6-2: LED Port**

LED Reference (As shown on silkscreen)	Microcontroller Port Pin function	Microcontroller Pin Number	Polarity
LED0	Port B bit 12	130	Active Low
LED1	Port B bit 17	98	Active Low
LED2	Port B bit 18	99	Active Low
LED3	Port B bit 19	100	Active Low

Table 6-2: LED Port

6.3. Potentiometer

A single-turn potentiometer is connected to pin AN0 of the microcontroller. This may be used to vary the voltage at this pin between AVCC and Ground.

6.4. Serial port

One UART channel is connected to the D-type plug in position 'SERIAL' via an RS-232 transceiver. Other channels can be used by changing the 0Ω link resistors. The links to be fitted are listed in **Table 6-3: Serial Options Links**

Serial port	R81	R93	R80	R95	R43	R68	R39	R38
SCI1 (default)	No fit	No fit	Fit	Fit	No fit	No fit	No fit	No fit
SCI2	No fit	No fit	No fit	No fit	Fit	Fit	No fit	No fit
External serial	Fit	Fit	No fit	No fit	No fit	No fit	No fit	No fit

Table 6-3: Serial Options Links

The SCI1 and SCI2 port pins are also available on JA6 header.

The board is designed to accept a straight-through RS-232 male-to-female cable.

6.5. Debug LCD Module

The LCD module supplied with the RSK can be connected to the connector 'LCD' for use with the tutorial code. Any module that conforms to the pin connections and has a KS0066u-compatible controller can be used. The LCD module uses a 4 bit interface to reduce the pin allocation. No contrast control is provided; this must be set on the display module.

The pin allocation and signal names used on this connector are shown in **Table 6-4:LCD Module connections**

The module supplied with the MCU board only supports 5V operation.

LCD					
Pin	Circuit Net Name	Device Pin	Pin	Circuit Net Name	Device Pin
1	Ground	-	2	5V Only	-
3	No Connection	-	4	DLCDRS	65
5	R/W (Wired to Write only)	-	6	DLCDE	64
7	No Connection	-	8	No connection	-
9	No Connection	-	10	No connection	-
11	DLCD4	70	12	DLCD5	71
13	DLCD6	72	14	DLCD7	73

Table 6-4: LCD Module Connections

6.6.USB Module

The USB module can be used for USB device modes at full speed. **Table 6-5: USB connections** contain details of the signal descriptions and pin connections.

Description	Function	Microcontroller Pin Number	Header Pins
VBUS_DET	Device mode: External USB power supply monitor pin.	106	J3-18
USD+	USB data I/O pin	108	Not available
USD-	USB data I/O pin	109	Not available
CON_USBEXTAL	USB clock pin	104	J3-16
CON_USBXTAL	USB clock pin	103	J3-15

Table 6-5: USB Connections

6.7.RCAN Module

The RCAN module can be used for CAN interface. **Table 6-6: RCAN connections** contain details of the pin connections.

Description	Function	Microcontroller Pin Number	Header Pins
CAN H	CAN HIGH differential line	-	CAN-1
CAN L	CAN LOW differential line	-	CAN-3
GROUND	GROUND	-	CAN-2

Table 6-6: CAN Connections

6.8. Option Links

Table 6-7 below describes the function of the option links contained on this RSK board and associated with Serial Port Configuration.

The default configuration is indicated by **BOLD** text.

Serial Port Option Link Settings			
Reference	Fitted	Not fitted	Related To
R69	Connects the programming port (Rx) to the E8A connector.	Disconnects the programming port (Rx) from the E8A connector.	R55,R60,R72
R60	Connects the programming port (Tx) to the E8A connector.	Disconnects the programming port (Tx) from the E8A connector.	R69, R55, R72
R74	Disables the RS-232 Transceiver	Enables the RS-232 Transceiver	R65
R68	Connects the alternate serial port (TXD2) to the D-type connector	Disconnects the alternate serial port (TXD2) from the D-type connector.	R38,R39,R43
R43	Connects serial port RXD2 to the SERIAL D-type connector.	Disconnects serial port RXD2 from the SERIAL D-type connector.	R38,R39,R68
R80	Connects serial port TXD1 to the SERIAL D-type connector.	Disconnects serial port TXD1 from the SERIAL D-type connector.	R95
R95	Connects serial port RXD1 to the D-type connector.	Disconnects serial port RXD1 from the D-type connector.	R80
R81	Routes RS232 serial port TXD1 to application connector (JA6).	Disconnects RS232 serial port TXD1 from application connector (JA6).	R80,R95,R93
R93	Routes the RS-232 serial port RXD1 to application connector (JA6).	Disconnects the RS-232 serial port RXD1 from application connector (JA6).	R95,R81,R80

Table 6-7 : Serial port configuration links

Table 6-8 below describes the function of the option links contained on this RSK board and associated with Power Configuration.

The default configuration is indicated by **BOLD** text.

Power Supply Option Link Settings				
Reference	Function	Fitted	Not fitted	Related To
R4	Power Source	Board can be powered from the PWR connector.	Disconnects the supply from the PWR connector.	R25, R20
R20	Power	Connect Board_VCC to CON_5V.	Disconnect Board_VCC from CON_5V.	R4, R25, R20
R25	Power Source	Connects regulated 5V voltage source to Board_VCC.	Disconnects regulated 5V voltage source from Board_VCC.	R4, R20
R28	Microcontroller Power Supply	Supply power to the Microcontroller.	Fit a Low ohmic resistor to measure the MCU current.	R4, R25, R20
R32	Power Source	Connects regulated 3.3V voltage source to Board_VCC.	Disconnects regulated 3.3V voltage source from Board_VCC.	R4, R25 R31

Table 6-8: Power configuration links

Table 6-9 below describes the function of the option links contained on this RSK board and associated with Vref and Analog supply Configuration.

The default configuration is indicated by **BOLD** text.

Vref and Analog supply Option Link Settings				
Reference	Function	Fitted	No fitted	Related To
R40	Analog Voltage Source	Links the analog ground to the digital ground.	Isolates the analog ground from the digital ground.	-
R66	Voltage Reference Source	Connects VREF to CON_VREF on JA1.	Disconnects VREF from CON_VREF.	R83
R83	Voltage Reference Source	Connects VREF to Board_5V.	Disconnects VREF from Board_5V.	R66
R89	Analog Voltage Source	Connects AVCC to CON_AVCC on JA1.	Disconnects AVCC from CON_AVCC.	R96
R96	Analog Voltage Source	Connects AVCC to Board_5V.	Disconnects AVCC from Board_5V.	R89

Table 6-9: Analog configuration links

Table 6-10 below describes the function of the option links contained on this RSK board and associated with Pin function.

The default configuration is indicated by **BOLD** text.

Pin Function select Option Link Settings				
Reference	Function	Fitted	No fitted	Related To
R113	Pin function select	Connects PIN 169 to RXD2 on JA6.	Disconnects PIN 169 from RXD2.	R85, R43
R59	Pin function select	Connects PIN 79 WRLn on JA3.	Disconnects PIN 79 from WRLn.	R63
R63	Pin function select	Connects PIN 79 to WRn on JA3.	Disconnects PIN 79 from WRn.	R59
R138	Pin function select	Connects PIN 171 to M1_TRISTn_SCK2 on JA2.	Disconnects PIN 171 from M1_TRISTn.	R137
R44	Pin function select	Connects PIN 165 to SCK0 on JA2.	Disconnects PIN 165 from SCK0.	R51
R47	Pin function select	Connects PIN 50 to D12 on JA3.	Disconnects PIN 50 from D12.	R54
R51	Pin function select	Connects PIN 165 to CS2n on JA3.	Disconnects PIN 165 from CS2n.	R44
R52	Pin function select	Connects PIN 48 to D10 on JA3.	Disconnects PIN 48 from D10.	R56
R54	Pin function select	Connects PIN 50 to M2_Vp on JA5.	Disconnects PIN 50 from M2_Vp.	R47
R55	Pin function select	Connects PIN 164 to CS1n on JA3.	Disconnects PIN 164 from CS1n.	R60
R56	Pin function select	Connects PIN 48 to M2_Up on JA5.	Disconnects PIN 48 from M2_Up.	R52
R58	Pin function select	Connects PIN 52 to D14 on JA3.	Disconnects PIN 52 from D14.	R64
R60	Pin function select	Connects PIN 164 to the E8A.	Disconnects PIN 164 from the E8A.	R55
R61	Pin function select	Connects PIN 49 to D11 on JA3.	Disconnects PIN 49 from D11.	R67
R64	Pin function select	Connects PIN 52 to M2_Vn on JA5.	Disconnects PIN 52 from M2_Vn.	R58
R67	Pin function select	Connects PIN 49 to M2_Un on JA5.	Disconnects PIN 49 from M2_Un.	R61
R69	Pin function select	Connects PIN 163 to the E8A.	Disconnects PIN 163 from the E8A.	R72
R70	Pin function select	Connects PIN 51 to D13 on JA3.	Disconnects PIN 51 from D13.	R73

R71	Pin function select	Connects PIN 10 to IO_1 on JA1.	Disconnects PIN 10 from IO_1.	R75
R72	Pin function select	Connects PIN 163 to CS0n on JA3.	Disconnects PIN 163 from CS0n.	R69
R73	Pin function select	Connects PIN 51 to M2_Wp on JA5.	Disconnects PIN 51 from M2_Wp.	R70
R75	Pin function select	Connects PIN 10 to A1 on JA3.	Disconnects PIN 10 from A1.	R71
R76	Pin function select	Connects PIN 53 to D15 on JA3.	Disconnects PIN 53 from D15.	R84
R77	Pin function select	Connects PIN 172 to UD on JA2.	Disconnects PIN 172 from UD.	R135
R78	Pin function select	Connects PIN 9 to IO_0 on JA1.	Disconnects PIN 9 from IO_0.	R86
R84	Pin function select	Connects PIN 53 to M2_Wn on JA5.	Disconnects PIN 53 from M2_Wn.	R76
R86	Pin function select	Connects PIN 9 to A0 on JA3.	Disconnects PIN 9 from A0.	R78
R87	Pin function select	Connects PIN 138 to AD_POT.	Disconnects PIN 138 from AD_POT.	R91
R88	Pin function select	Connects PIN 12 to IO_3 on JA1.	Disconnects PIN 12 from IO_3.	R92
R91	Pin function select	Connects PIN 138 to AN0 on JA1.	Disconnects PIN 138 from AN0.	R87
R92	Pin function select	Connects PIN 12 to A3 on JA3.	Disconnects PIN 12 from A3.	R88
R97	Pin function select	Connects PIN 11 to IO_2 on JA1.	Disconnects PIN 11 from IO_2.	R99
R99	Pin function select	Connects PIN 11 to A2 on JA3.	Disconnects PIN 11 from A2.	R97
R100	Pin function select	Connects PIN 14 to IO_5 on JA1.	Disconnects PIN 14 from IO_5.	R45
R103	Pin function select	Connects PIN 13 to IO_4 on JA1.	Disconnects PIN 13 from IO_4.	R104
R45	Pin function select	Connects PIN 14 to A5 on JA3.	Disconnects PIN 14 from A5.	R100
R104	Pin function select	Connects PIN 13 to A4 on JA3.	Disconnects PIN 13 from A4.	R103

R105	Pin function select	Connects PIN 16 to IO_7 on JA1.	Disconnects PIN 16 from IO_7.	R53
R53	Pin function select	Connects PIN 16 to A7 on JA3.	Disconnects PIN 16 from A7.	R105
R109	Pin function select	Connects PIN 15 to IO_6 on JA1.	Disconnects PIN 15 from IO_6.	R111
R111	Pin function select	Connects PIN 15 to A6 on JA3.	Disconnects PIN 15 from A6.	R109
R41	Pin function select	Connects PIN 46 to D8 on JA3.	Disconnects PIN 46 from D8.	R42
R42	Pin function select	Connects PIN 46 to M2_TRISTn on JA5.	Disconnects PIN 46 from M2_TRISTn.	R41
R135	Pin function select	Connects PIN 172 to TXD2 on JA6.	Disconnects PIN 172 from TXD2.	R77
R137	Pin function select	Connects PIN 171 to SCK2 on JA6.	Disconnects PIN 171 from SCK2.	R138
R85	Pin function select	Connects PIN 169 to TRIGb on JA2.	Disconnects PIN 169 from TRIGb.	R113

Table 6-10: Pin function configuration links

Table 6-11: Clock configuration links below describes the function of the option links associated with Clock configuration. The default configuration is indicated by **BOLD** text.

Clock Configuration Option Link Settings				
Reference	Function	Fitted	Not fitted	Related To
R112	USB clock oscillator	Connects the external USB clock from the MCU	Disconnects the external USB clock from the MCU	R120, R118, R119
R115	Clock Oscillator	Connects the external clock to the MCU.	Disconnects the external clock connection to the MCU.	R116, R114, R122
R118	USB clock oscillator	Connects the external USB clock to the MCU	Disconnects the external USB clock to the MCU	R120, R112, R119
R120	USB clock oscillator	Connects the on-board USB clock to the MCU.	External Clock Source can be connected.	R112, R118, R119
R119	USB clock oscillator	Connects the on-board USB clock from the MCU.	External Clock Source can be connected.	R112, R120, R118
R126	Clock Oscillator	Parallel resistor for crystal.	Not fitted.	-
R122	Clock Oscillator	Connects the on-board clock from the MCU.	External Clock Source can be connected.	R115, R114, R116
R116	Clock Oscillator	Connects external clock from MCU.	Disconnects the external clock connection to the MCU.	R115, R114, R122

Table 6-11: Clock configuration links

6.9. Oscillator Sources

A crystal oscillator is fitted on the MCU board and used to supply the main clock input to the Renesas microcontroller. The oscillators that are fitted and alternative footprints provided on this MCU board are detailed in **Table 6-12: Oscillators / Resonators**

Component		
Crystal (X1)	Fitted	12.5MHz (HC49/4H package)
Crystal (X2)	Fitted	48MHz (HC49/4H package)

Table 6-12: Oscillators / Resonators

Warning: When replacing the default oscillator with that of another frequency, the debugging monitor will not function until the debugger settings are modified.

6.10. Reset Circuit

The MCU Board includes a simple latch circuit that links the mode selection and reset circuit. This provides an easy method for swapping the device between Boot Mode and User mode. This circuit is not required on customers' boards as it is intended for providing easy evaluation of the operating modes of the device on the RSK. Please refer to the hardware manual for more information on the requirements of the reset circuit.

The reset circuit operates by latching the state of the boot switch (SW1) on pressing the reset button. This control is subsequently used to modify a port pin state to select which code is executed.

The reset is held in the active state for a fixed period by a pair of resistors and a capacitor. Please check the reset requirements carefully to ensure the reset circuit on the user's board meets all the reset timing requirements.

Chapter 7. Modes

The MCU board can be configured in User mode and Boot mode. User mode may be used to run and debug user code, while Boot mode may only be used to program the Renesas microcontroller with program code via the SCI1 interface. Further details of programming the flash are available in the SH7286 device hardware manual.

The MCU board provides the capability of changing between User and Boot / User Boot modes using a simple latch circuit. This is only to provide a simple mode control on this board when the E10A debugger is not in use.

To manually enter boot mode, press and hold the SW1/BOOT. The mode pins are held in their boot states while reset is pressed and released. Release the boot button. The BOOT LED will be illuminated to indicate that the microcontroller is in boot mode.

More information on the operating modes can be found in the device hardware manual.

7.1. Boot mode

The boot mode settings for this MCU board are shown in Table 7-1 :

FWE	MD1	MD0	LSI State after Reset End
1	0	0	Boot Mode

Table 7-1: Boot Mode pin settings

7.2. User Mode

The SH7286 supports various user modes. The default user program mode for the RSKSH7286 is as shown in Table 7-2.

WE	MD1	MD0	LSI State after Reset End
1	1	0	User Program Mode

Table 7-2: User Program Mode pin settings

The SH7286 supports another user mode. The user boot mode for the RSKSH7286 is shown in Table 7-3.

WE	MD1	MD0	LSI State after Reset End
1	0	1	User Boot Mode

Table 7-3: User Boot Mode pin settings

Chapter 8. Programming Methods

The board is intended for use with HEW and the supplied E10A debugger only. Please refer to *SH7280 Group Hardware Manual* for details of the programming methods using the on-chip serial port SCI0 and without using E10A debugger.

Chapter 9. Headers

9.1. Microcontroller Headers

The microcontroller pin headers and their corresponding microcontroller connections are detailed in this section (Table 9-1 to Table 9-4).

The header pins connect directly to the microcontroller pins.

J1					
Pin	Circuit Net Name	Device Pin	Pin	Circuit Net Name	Device Pin
1	M1_Vn	1	23	Ground	23
2	M1_Wn	2	24	A13	24
3	UC_VCC	3	25	A14	25
4	Not connected	4	26	A15	26
5	Ground	5	27	A16	27
6	PIN6	6	28	A17	28
7	CASn	7	29	SCL	29
8	RASn	8	30	SDA	30
9	A0_IO_0	9	31	A18	31
10	A1_IO_1	10	32	A19	32
11	A2_IO_2	11	33	A20	33
12	A3_IO_3	12	34	UC_VCC	34
13	A4_IO_4	13	35	Ground	35
14	A5_IO_5	14	36	D0	36
15	A6_IO_6	15	37	D1	37
16	A7_IO_7	16	38	D2	38
17	A8	17	39	D3	39
18	A9	18	40	D4	40
19	A10	19	41	D5	41
20	A11	20	42	D6	42
21	A12	21	43	D7	43
22	UC_VCC	22	44	UC_VCC	44

Table 9-1: J1 microcontroller header

J2					
Pin	Circuit Net Name	Device Pin	Pin	Circuit Net Name	Device Pin
1	Ground	45	23	Ground	67
2	D8_M2_TRISTn	46	24	DREQ	68
3	D9	47	25	DACK	69
4	D10_M2_Up	48	26	DLCD4	70
5	D11_M2_Un	49	27	DLCD5	71
6	D12_M2_Vp	50	28	DLCD6	72
7	D13_M2_Wp	51	29	DLCD7	73
8	D14_M2_Vn	52	30	ADTRGn	74
9	D15_M2_Wn	53	31	UC_VCC	75
10	Not connected	-	32	Ground	76
11	UC_VCC	55	33	CAN_EN	77
12	Ground	56	34	RDn	78
13	IRQ0	57	35	WRn_WRLn	79
14	IRQ1	58	36	WRHn	80
15	IRQ2	59	37	CAN_ERRn	81
16	IRQ3	60	38	CAN_STBn	82
17	SCK4	61	39	TCLKD	83
18	TXD4	62	40	TCLKC	84
19	RXD4	63	41	SCK3	85
20	DLCDE	64	42	PIN86	86
21	DLCDRS	65	43	UC_VCC	87
22	UC_VCC	66	44	Ground	88

Table 9-2: J2 microcontroller header

J3					
Pin	Circuit Net Name	Device Pin	Pin	Circuit Net Name	Device Pin
1	TDI	89	23	PB10	111
2	TDO	90	24	Ground	112
3	TCK	91	25	CON_XTAL	113
4	TMS	92	26	UC_VCC	114
5	TRSTn	93	27	CON_EXTAL	115
6	UC_VCC	94	28	NMI	116
7	Ground	95	29	Ground	117
8	A21	96	30	NC	-
9	A22	97	31	NC	-
10	LED1	98	32	TIOC0A	120
11	LED2	99	33	TIOC0B	121
12	LED3	100	34	TIOC0C	122
13	UC_VCC	101	35	TEND	123
14	Ground	102	36	TMR0	124
15	CON_USBXTAL	103	37	TMR1	125
16	CON_USBEXTAL	104	38	TRIGa	126
17	USPND	105	39	UC_VCC	127
18	VBUS_DET	106	40	Ground	128
19	NC	-	41	PIN129	129
20	NC	-	42	LED0	130
21	NC	-	43	CAN1TX	131
22	NC	-	44	CAN1RX	132

Table 9-3: J3 microcontroller header

J4					
Pin	Circuit Net Name	Device Pin	Pin	Circuit Net Name	Device Pin
1	RESn	133	23	AVSS	155
2	FWE_ASEBRKn	134	24	AVCC	156
3	ASEMD0n	135	25	AVSS	157
4	AVSS	136	26	DA0	158
5	AVCC	137	27	DA1	159
6	AN0_AD POT	138	28	MD0	160
7	AN1	139	29	MD1	161
8	AN2	140	30	WDT_OVF _n	162
9	AN3	141	31	PTRX_CS0 _n	163
10	AN4	142	32	PTTX_CS1 _n	164
11	AN5	143	33	SCK0_CS2 _n	165
12	AN6	144	34	RXD1	166
13	AN7	145	35	TXD1	167
14	VREF	146	36	SCK1	168
15	AVSS	147	37	TRIG _b _RXD2	169
16	AVCC	148	38	Ground	170
17	AVSS	149	39	M1_TRIST _n _SCK2	171
18	AN8	150	40	UD_TXD2	172
19	AN9	151	41	M1_Up	173
20	AN10	152	42	M1_Un	174
21	AN11	153	43	M1_V _p	175
22	VREF	154	44	M1_W _p	176

Table 9-4: J4 microcontroller header

9.2. Application Headers

Standard application header connections are detailed in this section (Table 9-5 to Table 9-9).

* marks pins where a link to the microcontroller pin is via a fitted 0Ω link

JA1							
Pin	Header Name	MCU board Signal Name	Device Pin	Pin	Header Name	MCU board Signal Name	Device Pin
1	5V	CON_5V	---	14	DAC1	DA1	159
2	0V(5V)	GROUND	---	15	IO_0	IO_0	9*
3	3V3	CON_3V3	---	16	IO_1	IO_1	10*
4	0V(3V3)	GROUND	---	17	IO_2	IO_2	11*
5	AVcc	CON_AVCC	137, 148, 156	18	IO_3	IO_3	12*
6	AVss	CON_AVSS	136, 149, 157	19	IO_4	IO_4	13*
7	AVref	CON_VREF	146, 154	20	IO_5	IO_5	14*
8	ADTRG	ADTRGn	74	21	IO_6	IO_6	15*
9	AD0	AN0	138*	22	IO_7	IO_7	16*
10	AD1	AN1	139	23	IRQ3	IRQ3	60
11	AD2	AN2	140	24	IIC_EX	NC	---
12	AD3	AN3	141	25	IIC_SDA	SDA	30
13	DAC0	DA0	158	26	IIC_SCL	SCL	29

Table 9-5: JA1 Standard Generic Header

JA2							
Pin	Header Name	MCU board Signal Name	Device Pin	Pin	Header Name	MCU board Signal Name	Device Pin
1	RESn	RESn	133	14	Un	M1_Un	174
2	EXTAL	CON_EXTAL	115	15	Vp	M1_Vp	175
3	NMI	NMI	116	16	Vn	M1_Vn	1
4	Vss1	GROUND	-	17	Wp	M1_Wp	176
5	WDT_OVF	WDT_OVFn	162	18	Wn	M1_Wn	2
6	SClTX	PTTX	164	19	TMR0	TMR0	124
7	IRQ0	IRQ0	57	20	TMR1	TMR1	125
8	SClRX	PTRX	163	21	TRIGa	TRIGa	126
9	IRQ1	IRQ1	58	22	TRIGb	TRIGb	169
10	SClCK	SCK0	165	23	IRQ2	IRQ2	59
11	UD	UD	172	24	TRISTn	M1_TRISTn	171
12	CTSRTS	NC	---	25	Reserved	NC	-
13	Up	M1_Up	173	26	Reserved	NC	-

Table 9-6: JA2 Standard Generic Header

JA3							
Pin	Header Name	MCU board Signal Name	Device Pin	Pin	Header Name	MCU board Signal Name	Device Pin
1	A0	A0	9*	26	WRn	WRn	79*
2	A1	A1	10*	27	CS0n	CS0n	163*
3	A2	A2	11*	28	CS1n	CS1n	164*
4	A3	A3	12*	29	D8	D8	46*
5	A4	A4	13*	30	D9	D9	47
6	A5	A5	14*	31	D10	D10	48*
7	A6	A6	15*	32	D11	D11	49*
8	A7	A7	16*	33	D12	D12	50*
9	A8	A8	17	34	D13	D13	51*
10	A9	A9	18	35	D14	D14	52*
11	A10	A10	19	36	D15	D15	53*
12	A11	A11	20	37	A16	A16	27
13	A12	A12	21	38	A17	A17	28
14	A13	A13	24	39	A18	A18	31
15	A14	A14	25	40	A19	A19	32
16	A15	A15	26	41	A20	A20	33
17	D0	D0	36	42	A21	A21	96
18	D1	D1	37	43	A22	A22	97
19	D2	D2	38	44	SDCLK	NC	---
20	D3	D3	39	45	CS2n	CS2n	165*
21	D4	D4	40	46	ALE	NC	---
22	D5	D5	41	47	WRHn	WRHn	80
23	D6	D6	42	48	WRLn	WRLn	79*
24	D7	D7	43	49	CASn	CASn	7
25	RDn	RDn	78	50	RASn	RASn	8

Table 9-7: JA3 Standard Generic Header

JA5							
Pin	Header Name	MCU board Signal Name	Device Pin	Pin	Header Name	MCU board Signal Name	Device Pin
1	AD4	AN4	142	13	TIOC0A	TIOC0A	120
2	AD5	AN5	143	14	TIOC0B	TIOC0B	121
3	AD6	AN6	144	15	TIOC0C	TIOC0C	122
4	AD7	AN7	145	16	M2_TRISTn	M2_TRISTn	46*
5	CAN1TX	CAN1TX	131	17	TCLKC	TCLKC	84
6	CAN1RX	CAN1RX	132	18	TCLKD	TCLKD	83
7	CAN2TX	NC	---	19	M2_Up	M2_Up	48*
8	CAN2RX	NC	---	20	M2_Un	M2_Un	49*
9	AD8	AN8	150	21	M2_Vp	M2_Vp	50*
10	AD9	AN9	151	22	M2_Vn	M2_Vn	51*
11	AD10	AN10	152	23	M2_Wp	M2_Wp	52*
12	AD11	AN11	153	24	M2_Wn	M2_Wn	53*

Table 9-8: JA5 Standard Generic Header

JA6							
Pin	Header Name	MCU board Signal Name	Device Pin	Pin	Header Name	MCU board Signal Name	Device Pin
1	DREQ	DREQ	68	13	Reserved	NC	-
2	DACK	DACK	69	14	Reserved	NC	-
3	TEND	TEND	123	15	Reserved	NC	-
4	STBYn	NC	---	16	Reserved	NC	-
5	RS232TX	RS232TX	---	17	Reserved	NC	-
6	RS232RX	RS232RX	---	18	Reserved	NC	-
7	SCl b RX	RXD1	166	19	Reserved	NC	-
8	SCl b TX	TXD1	167	20	Reserved	NC	-
9	SCl c TX	TXD2	172*	21	Reserved	NC	-
10	SCl b CK	SCK1	168	22	Reserved	NC	-
11	SCl c CK	SCK2	171*	23	Reserved	NC	-
12	SCl c RX	RXD2	169*	24	Reserved	NC	-

Table 9-9: JA6 Standard Generic Header

Chapter 10. Code Development

10.1. Overview

Note: For all code debugging using Renesas software tools, the MCU board must either be connected to a PC serial port via a serial cable or a PC USB port via an E10A.

Due to the continuous process of improvements undertaken by Renesas the user is recommended to review the information provided on the Renesas website at www.renesas.com to check for the latest updates to the Compiler and Debugger manuals.

10.2. Compiler Restrictions

The compiler supplied with this RSK is fully functional for a period of 60 days from first use. After the first 60 days of use have expired, the linker will limit the object size to a maximum of 256kB. To use the compiler with programs greater than this size you will need to purchase the full tools from your distributor.

Warning: The protection software for the compiler will detect changes to the system clock. Changes to the system clock back in time may cause the trial period to expire prematurely.

10.3. Breakpoint Support

This RSK is supplied with an E10A emulator which supports breakpoints in ROM. Instead of using breakpoints the User should use 'Eventpoints'.

'Eventpoints' are available for the both RAM and ROM memories. Up to 11 'Eventpoints' can be set into the user source code.

Double clicking in the 'Event' column in the code sets the 'Eventpoint'. 'Eventpoints' will remain unless they are double clicked to remove them.

10.4. Memory Map

The memory map shown below gives the locations of each memory area when operating the RSK in the default mode (Mode 2).

Mode 2 On-chip ROM enabled mode	
H'0000 0000 H'000F FFFF H'0010 0000	On-chip ROM (1024 Kbytes)
H'01FF FFFF H'0200 0000	Reserved area
H'03FF FFFF H'0400 0000	CS0 space
H'07FF FFFF H'0800 0000	CS1 space
H'0BFF FFFF H'0C00 0000	CS2 space
H'0FFF FFFF H'1000 0000	CS3 space
H'13FF FFFF H'1400 0000	CS4 space
H'17FF FFFF H'1800 0000	CS5 space
H'1BFF FFFF H'1C00 0000	CS6 space
H'1FFF FFFF H'2000 0000	CS7 space
	Reserved area
H'FFF7 FFFF H'FFF8 0000	On-chip RAM (32 Kbytes)
H'FFF8 7FFF H'FFF8 8000	Reserved area
H'FFFB FFFF H'FFFC 0000	SDRAM mode setting space
H'FFFC FFFF H'FFFD 0000	Reserved area
H'FFFD FFFF H'FFFE 0000 H'FFFF FFFF	On-chip peripheral I/O registers

Figure 10-1: Memory Map

Chapter 11. Component Placement

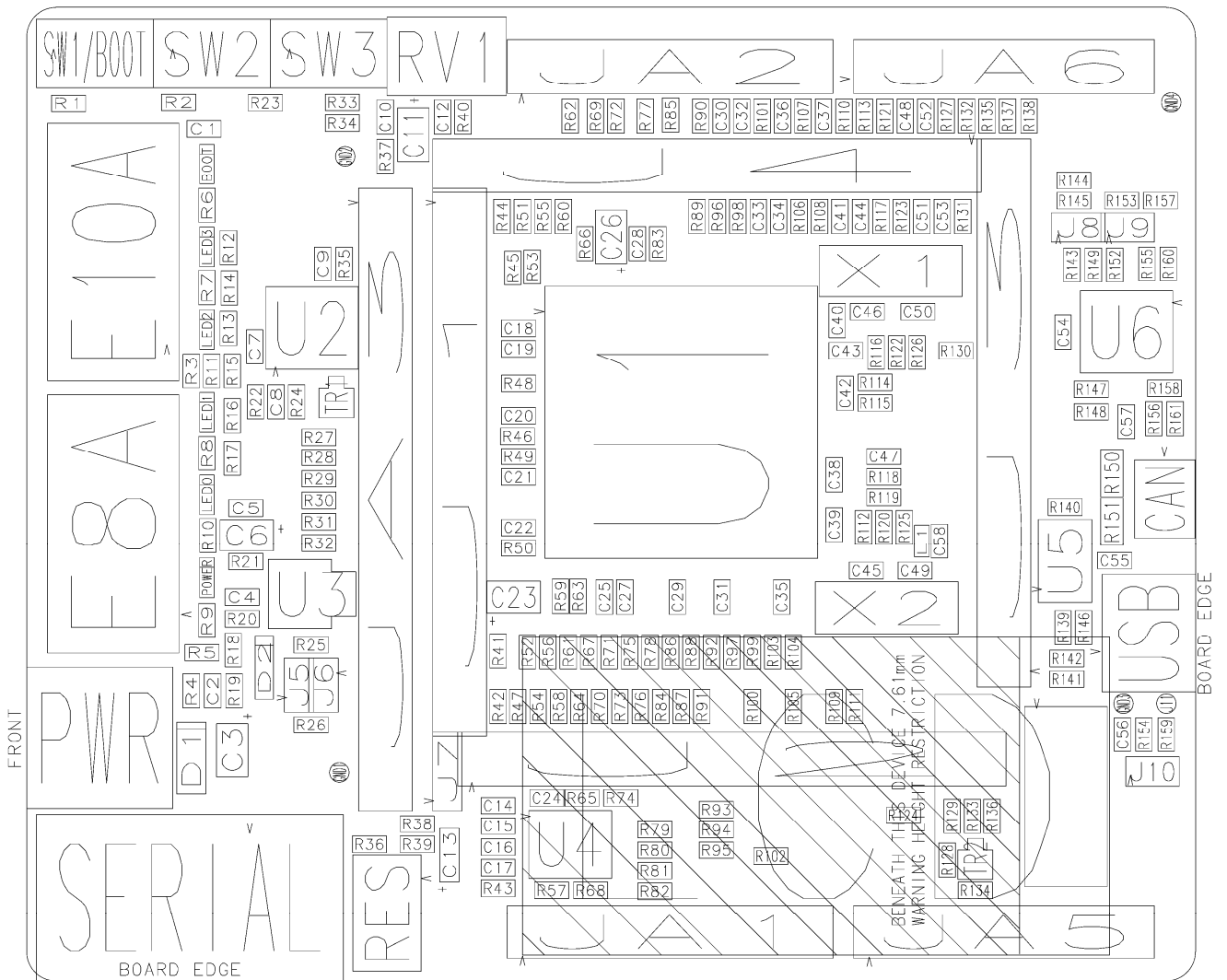

Figure 11-1: Component Placement (Top Layer)

Chapter 12. Additional Information

For details on how to use High-performance Embedded Workshop (HEW), refer to the HEW manual available on the CD or installed in the Manual Navigator.

For information about the SH7286 microcontrollers refer to the SH7280 Group *Hardware Manual*

For information about the SH7286 assembly language, refer to the SH-1/SH-2/SH-DSP *Software Manual*

For information about the E10A Emulator, please refer to the *SH Family E10A-USB Emulator User's Manual*

Online technical support and information is available at: http://www.renesas.com/renesas_starter_kits

Technical Contact Details

America: techsupport.rta@renesas.com

Europe: tools.support.eu@renesas.com

Japan: csc@renesas.com

General information on Renesas Microcontrollers can be found on the Renesas website at: <http://www.renesas.com/>

Renesas Starter Kit2 for SH7286

User's Manual

Publication Date Rev.1.00 01.Oct.2008

Published by: Renesas Technology Europe Ltd.

Duke's Meadow, Millboard Road, Bourne End

Buckinghamshire SL8 5FH, United Kingdom

©2008 Renesas Technology Europe and Renesas Solutions Corp., All Rights Reserved.

Renesas Starter Kit 2 for SH7286 User's Manual



Renesas Electronics Corporation

1753, Shimonumabe, Nakahara-ku, Kawasaki-shi, Kanagawa 211-8668 Japan

REG10J0147-0100