

To our customers,

Old Company Name in Catalogs and Other Documents

On April 1st, 2010, NEC Electronics Corporation merged with Renesas Technology Corporation, and Renesas Electronics Corporation took over all the business of both companies. Therefore, although the old company name remains in this document, it is a valid Renesas Electronics document. We appreciate your understanding.

Renesas Electronics website: <http://www.renesas.com>

April 1st, 2010
Renesas Electronics Corporation

Issued by: Renesas Electronics Corporation (<http://www.renesas.com>)

Send any inquiries to <http://www.renesas.com/inquiry>.

Notice

1. All information included in this document is current as of the date this document is issued. Such information, however, is subject to change without any prior notice. Before purchasing or using any Renesas Electronics products listed herein, please confirm the latest product information with a Renesas Electronics sales office. Also, please pay regular and careful attention to additional and different information to be disclosed by Renesas Electronics such as that disclosed through our website.
2. Renesas Electronics does not assume any liability for infringement of patents, copyrights, or other intellectual property rights of third parties by or arising from the use of Renesas Electronics products or technical information described in this document. No license, express, implied or otherwise, is granted hereby under any patents, copyrights or other intellectual property rights of Renesas Electronics or others.
3. You should not alter, modify, copy, or otherwise misappropriate any Renesas Electronics product, whether in whole or in part.
4. Descriptions of circuits, software and other related information in this document are provided only to illustrate the operation of semiconductor products and application examples. You are fully responsible for the incorporation of these circuits, software, and information in the design of your equipment. Renesas Electronics assumes no responsibility for any losses incurred by you or third parties arising from the use of these circuits, software, or information.
5. When exporting the products or technology described in this document, you should comply with the applicable export control laws and regulations and follow the procedures required by such laws and regulations. You should not use Renesas Electronics products or the technology described in this document for any purpose relating to military applications or use by the military, including but not limited to the development of weapons of mass destruction. Renesas Electronics products and technology may not be used for or incorporated into any products or systems whose manufacture, use, or sale is prohibited under any applicable domestic or foreign laws or regulations.
6. Renesas Electronics has used reasonable care in preparing the information included in this document, but Renesas Electronics does not warrant that such information is error free. Renesas Electronics assumes no liability whatsoever for any damages incurred by you resulting from errors in or omissions from the information included herein.
7. Renesas Electronics products are classified according to the following three quality grades: “Standard”, “High Quality”, and “Specific”. The recommended applications for each Renesas Electronics product depends on the product’s quality grade, as indicated below. You must check the quality grade of each Renesas Electronics product before using it in a particular application. You may not use any Renesas Electronics product for any application categorized as “Specific” without the prior written consent of Renesas Electronics. Further, you may not use any Renesas Electronics product for any application for which it is not intended without the prior written consent of Renesas Electronics. Renesas Electronics shall not be in any way liable for any damages or losses incurred by you or third parties arising from the use of any Renesas Electronics product for an application categorized as “Specific” or for which the product is not intended where you have failed to obtain the prior written consent of Renesas Electronics. The quality grade of each Renesas Electronics product is “Standard” unless otherwise expressly specified in a Renesas Electronics data sheets or data books, etc.
 - “Standard”: Computers; office equipment; communications equipment; test and measurement equipment; audio and visual equipment; home electronic appliances; machine tools; personal electronic equipment; and industrial robots.
 - “High Quality”: Transportation equipment (automobiles, trains, ships, etc.); traffic control systems; anti-disaster systems; anti-crime systems; safety equipment; and medical equipment not specifically designed for life support.
 - “Specific”: Aircraft; aerospace equipment; submersible repeaters; nuclear reactor control systems; medical equipment or systems for life support (e.g. artificial life support devices or systems), surgical implantations, or healthcare intervention (e.g. excision, etc.), and any other applications or purposes that pose a direct threat to human life.
8. You should use the Renesas Electronics products described in this document within the range specified by Renesas Electronics, especially with respect to the maximum rating, operating supply voltage range, movement power voltage range, heat radiation characteristics, installation and other product characteristics. Renesas Electronics shall have no liability for malfunctions or damages arising out of the use of Renesas Electronics products beyond such specified ranges.
9. Although Renesas Electronics endeavors to improve the quality and reliability of its products, semiconductor products have specific characteristics such as the occurrence of failure at a certain rate and malfunctions under certain use conditions. Further, Renesas Electronics products are not subject to radiation resistance design. Please be sure to implement safety measures to guard them against the possibility of physical injury, and injury or damage caused by fire in the event of the failure of a Renesas Electronics product, such as safety design for hardware and software including but not limited to redundancy, fire control and malfunction prevention, appropriate treatment for aging degradation or any other appropriate measures. Because the evaluation of microcomputer software alone is very difficult, please evaluate the safety of the final products or system manufactured by you.
10. Please contact a Renesas Electronics sales office for details as to environmental matters such as the environmental compatibility of each Renesas Electronics product. Please use Renesas Electronics products in compliance with all applicable laws and regulations that regulate the inclusion or use of controlled substances, including without limitation, the EU RoHS Directive. Renesas Electronics assumes no liability for damages or losses occurring as a result of your noncompliance with applicable laws and regulations.
11. This document may not be reproduced or duplicated, in any form, in whole or in part, without prior written consent of Renesas Electronics.
12. Please contact a Renesas Electronics sales office if you have any questions regarding the information contained in this document or Renesas Electronics products, or if you have any other inquiries.

(Note 1) “Renesas Electronics” as used in this document means Renesas Electronics Corporation and also includes its majority-owned subsidiaries.

(Note 2) “Renesas Electronics product(s)” means any product developed or manufactured by or for Renesas Electronics.

REV	REF	DATE	DRAWN BY
1	---	13.06.2006	DDE
2	ECR 1179	27.07.2006	DDE
3	ECO 909	09.01.2008	VNA

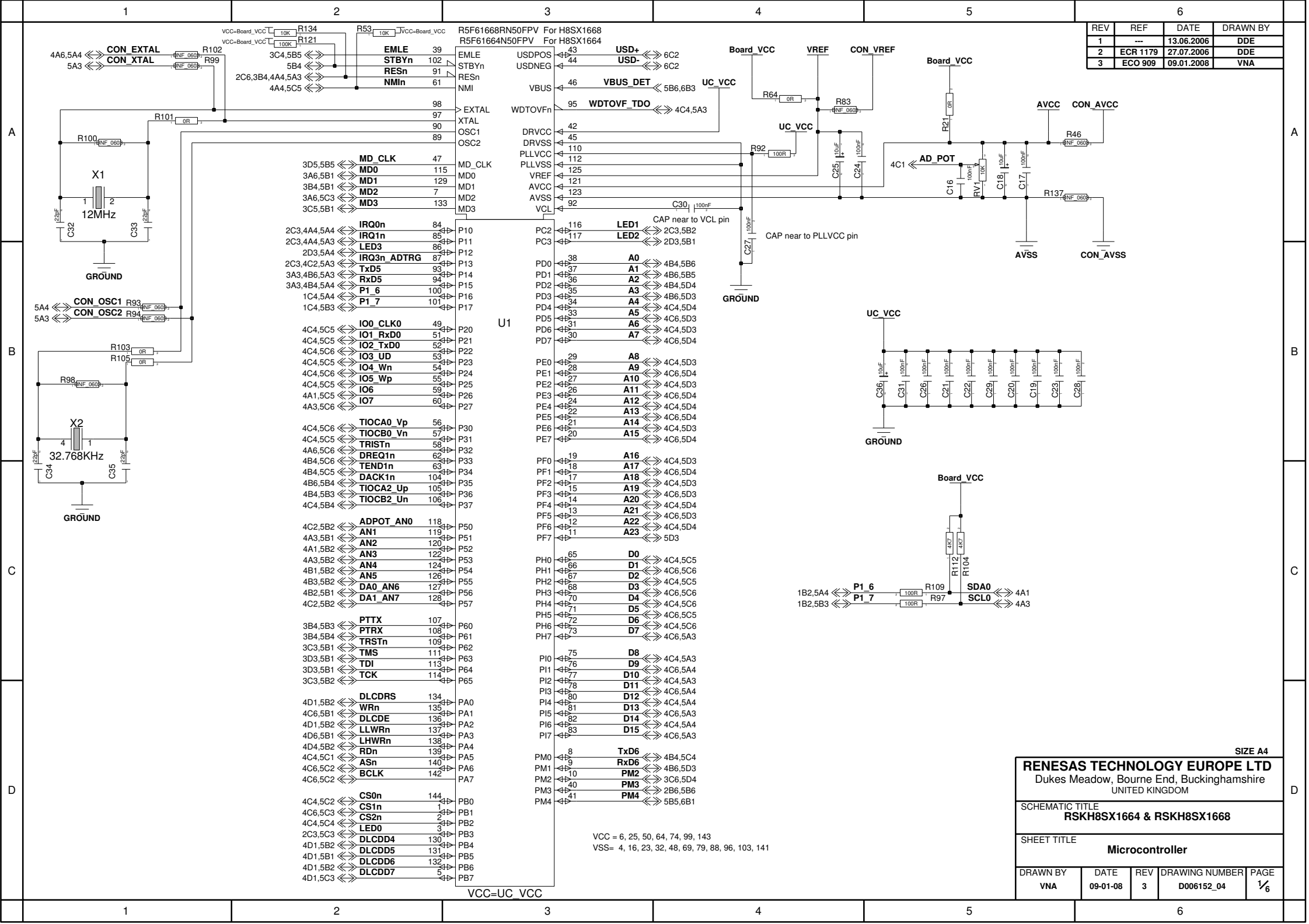

39	EMLE	43	USD+	6C2
102	STBYn	44	USD-	6C2
91	RESn	46	VBUS_DET	5B6,6B3
61	NMIIn	95	WDTOVF_TDO	4C4,5A3
98	EXTAL	42	DRVCC	
97	XTAL	45	DRVSS	
90	OSC1	110	PLLVCC	
89	OSC2	112	PLLVSS	
47	MD_CLK	125	VREF	
115	MD0	121	AVCC	
129	MD1	123	AVSS	
7	MD2	92	VCL	
133	MD3	116	LED1	2C3,5B2
84	IRQ0n	117	LED2	2D3,5B1
85	IRQ1n	38	A0	4B4,5B6
86	LED3	37	A1	4B6,5B5
87	IRQ3n_ADTRG	36	A2	4B4,5D4
93	TxD5	35	A3	4B6,5D3
94	RxD5	34	A4	4C4,5D4
100	P1_6	33	A5	4C6,5D3
101	P1_7	31	A6	4C4,5D3
49	IO0_CLK0	30	A7	4C6,5D4
51	IO1_RxD0	29	A8	4C4,5D3
52	IO2_TxD0	28	A9	4C6,5D4
53	IO3_UD	27	A10	4C4,5D3
54	IO4_Wn	26	A11	4C6,5D4
55	IO5_Wp	24	A12	4C4,5D4
58	IO6	22	A13	4C6,5D4
59	IO7	21	A14	4C4,5D3
56	TIOCA0_Vp	20	A15	4C6,5D4
57	TIOCB0_Vn	19	A16	4C4,5D3
58	TRISTn	18	A17	4C6,5D4
62	DREQ1n	17	A18	4C4,5D3
63	TEND1n	15	A19	4C6,5D3
104	DACK1n	14	A20	4C4,5D4
105	TIOCA2_Up	13	A21	4C6,5D3
106	TIOCB2_Un	12	A22	4C4,5D4
118	ADPOT_AN0	11	A23	5D3
119	AN1	65	D0	4C4,5C5
120	AN2	66	D1	4C6,5C6
121	AN3	67	D2	4C4,5C5
122	AN4	68	D3	4C6,5C6
123	AN5	70	D4	4C4,5C6
124	DA0_AN6	71	D5	4C6,5C5
125	DA1_AN7	72	D6	4C4,5C6
126	PTTX	73	D7	4C6,5A3
108	PTRX	75	D8	4C4,5A3
109	TRSTn	76	D9	4C6,5A4
111	TMS	77	D10	4C4,5A3
113	TDI	78	D11	4C6,5A4
114	TCK	80	D12	4C4,5A4
134	DLCDRS	81	D13	4C6,5A3
135	WRn	82	D14	4C4,5A4
136	DLCDE	83	D15	4C6,5A3
137	LLWRn	8	TxD6	4B4,5C4
138	LHWRn	9	RxD6	4B6,5D3
139	RDn	10	PM2	3C6,5D4
140	ASn	40	PM3	2B6,5B6
142	BCLK	41	PM4	5B5,6B1
144	CS0n			
1	CS1n			
2	CS2n			
3	LED0			
130	DLCDD4			
131	DLCDD5			
132	DLCDD6			
5	DLCDD7			

VCC = 6, 25, 50, 64, 74, 99, 143
VSS = 4, 16, 23, 32, 48, 69, 79, 88, 96, 103, 141

SHEET TITLE				
Microcontroller				
DRAWN BY	DATE	REV	DRAWING NUMBER	PAGE
VNA	09-01-08	3	D006152_04	1/6

POWER

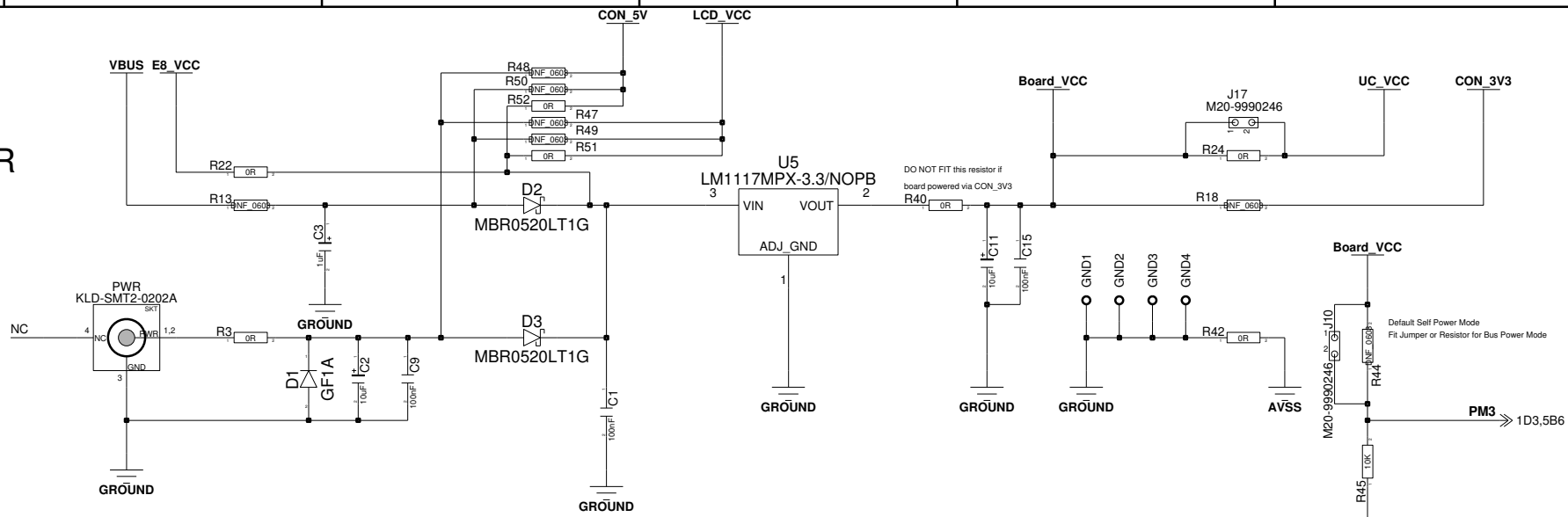

SWITCHES

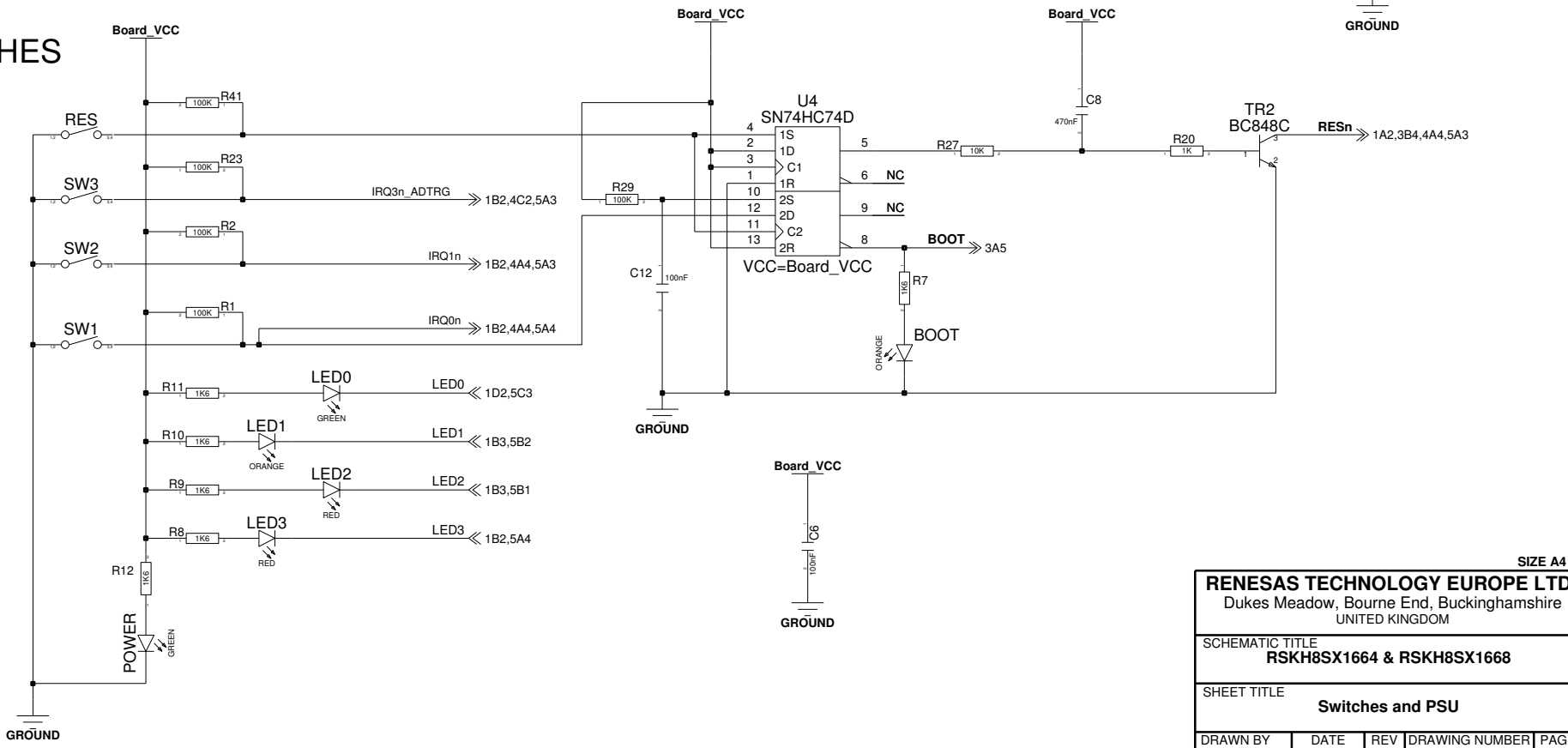

SIZE A4

RENESAS TECHNOLOGY EUROPE LTD				
Dukes Meadow, Bourne End, Buckinghamshire UNITED KINGDOM				
SCHEMATIC TITLE RSKH8SX1664 & RSKH8SX1668				
SHEET TITLE Switches and PSU				
DRAWN BY VNA	DATE 09-01-08	REV 3	DRAWING NUMBER D006152_04	PAGE 2/6

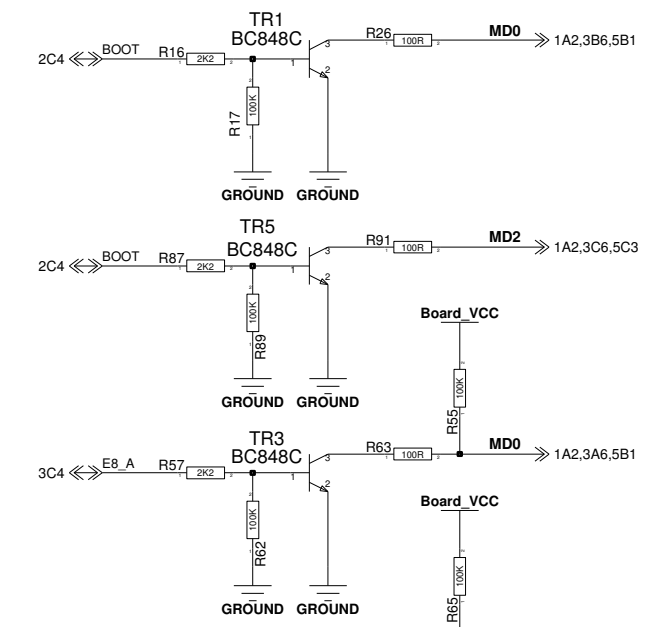
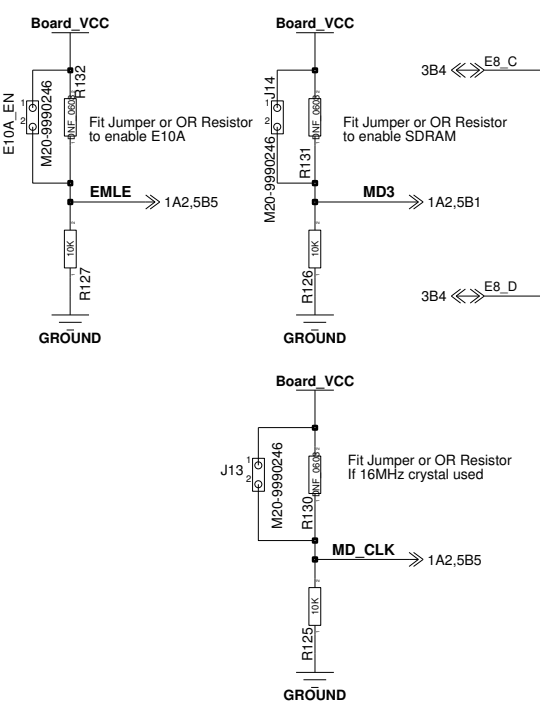
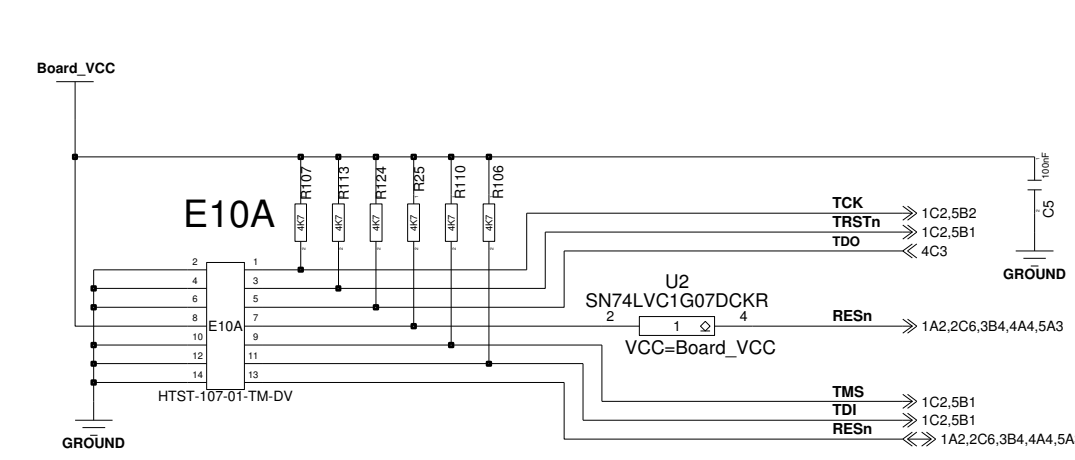
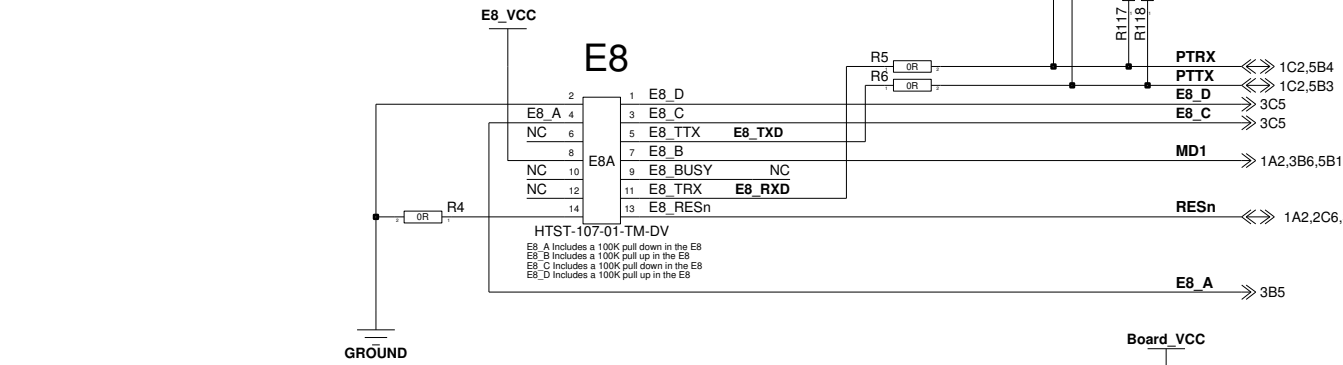
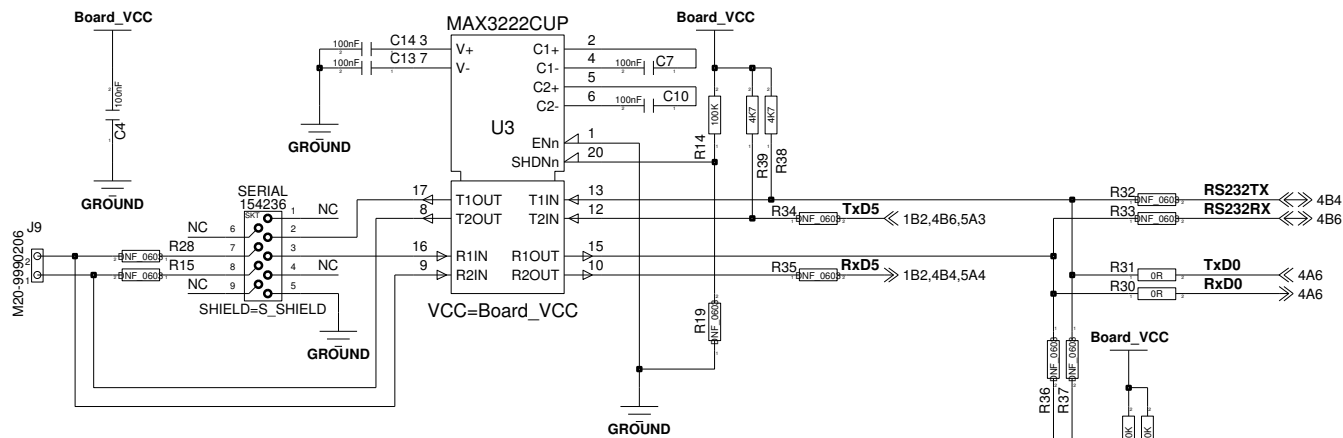

MD2	MD1	MD0	Boot Mode
0	1	0	Boot Mode
1	1	1	Single Chip Mode

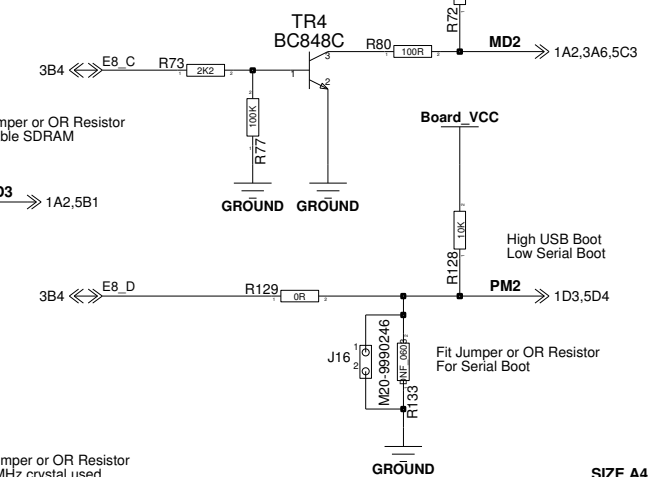

SIZE A4

RENESAS TECHNOLOGY EUROPE LTD
 Dukes Meadow, Bourne End, Buckinghamshire
 UNITED KINGDOM

SCHEMATIC TITLE
RSKH8SX1664 & RSKH8SX1668

SHEET TITLE
E8 & E10A Debug connectors & Serial Port

DRAWN BY VNA	DATE 09-01-08	REV 3	DRAWING NUMBER D006152_04	PAGE 3/6
-----------------	------------------	----------	------------------------------	-------------

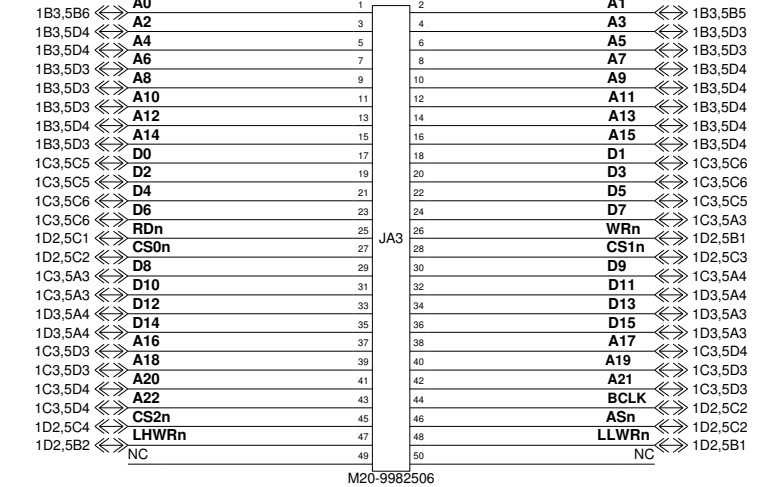
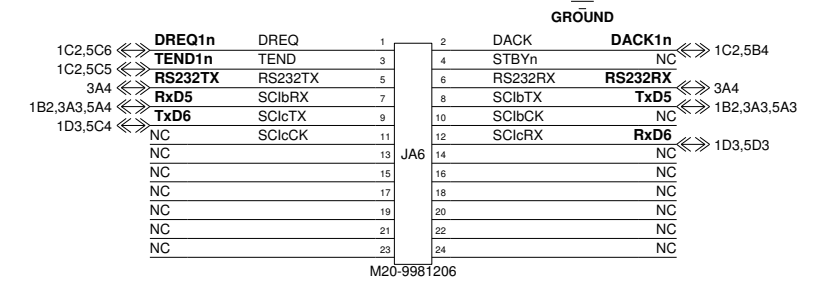
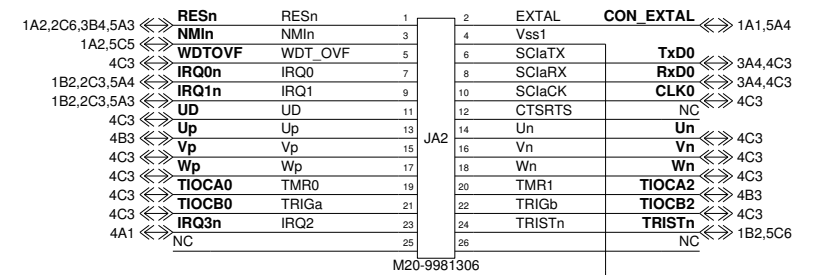
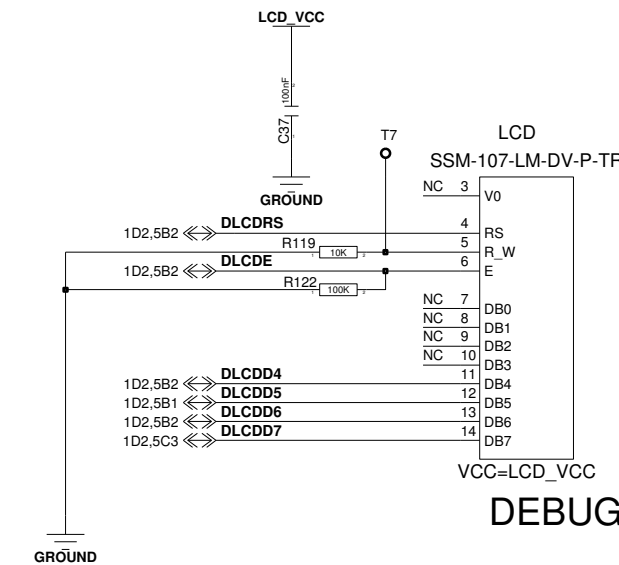
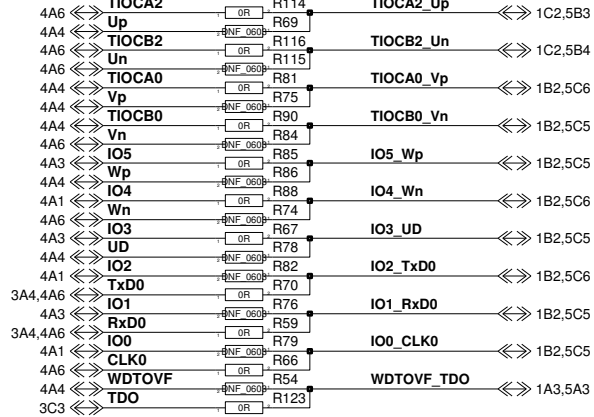
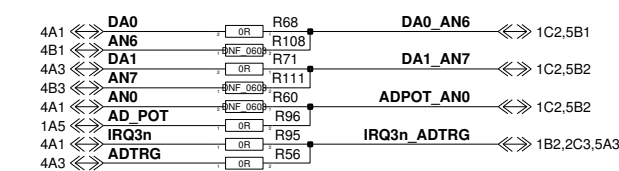
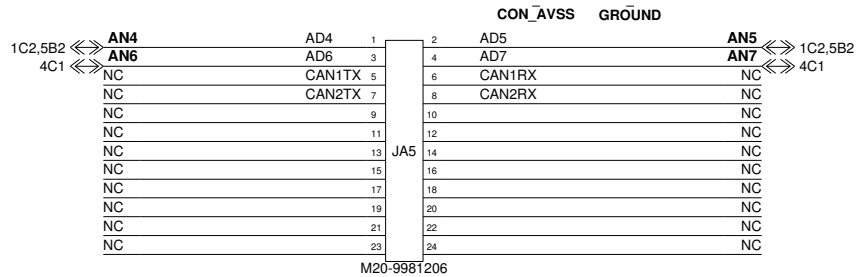
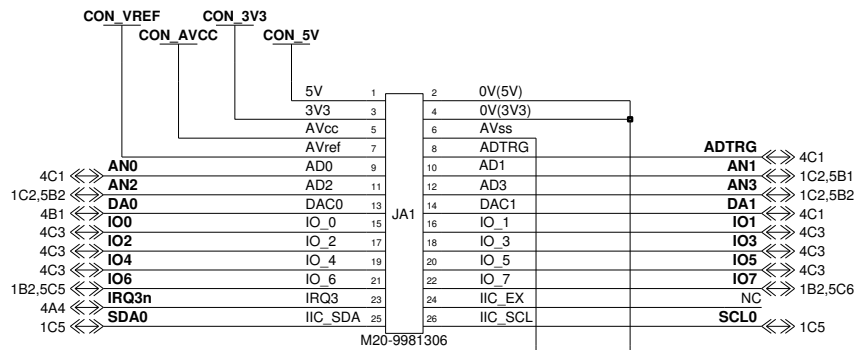

SIZE A4

RENESAS TECHNOLOGY EUROPE LTD
Dukes Meadow, Bourne End, Buckinghamshire
UNITED KINGDOM

SCHEMATIC TITLE
RSKH8SX1664 & RSKH8SX1668

SHEET TITLE
Application Headers

DRAWN BY VNA	DATE 09-01-08	REV 3	DRAWING NUMBER D006152_04	PAGE 4/6
-----------------	------------------	----------	------------------------------	-------------

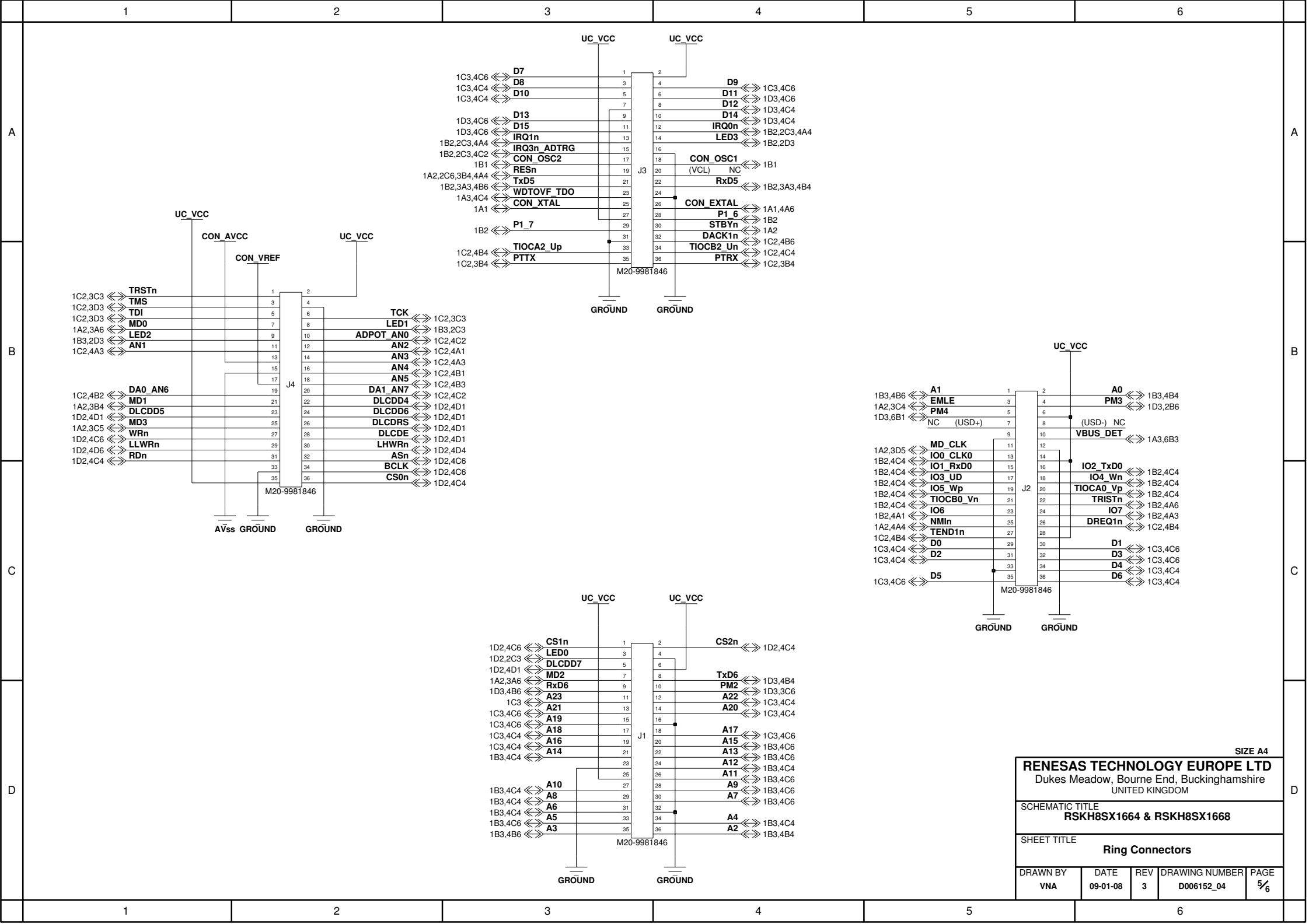

SIZE A4

RENESAS TECHNOLOGY EUROPE LTD
 Dukess Meadow, Bourne End, Buckinghamshire
 UNITED KINGDOM

SCHMATIC TITLE
RSKH8SX1664 & RSKH8SX1668

SHEET TITLE
Ring Connectors

DRAWN BY VNA	DATE 09-01-08	REV 3	DRAWING NUMBER D006152_04	PAGE 5/6
-----------------	------------------	----------	------------------------------	-------------

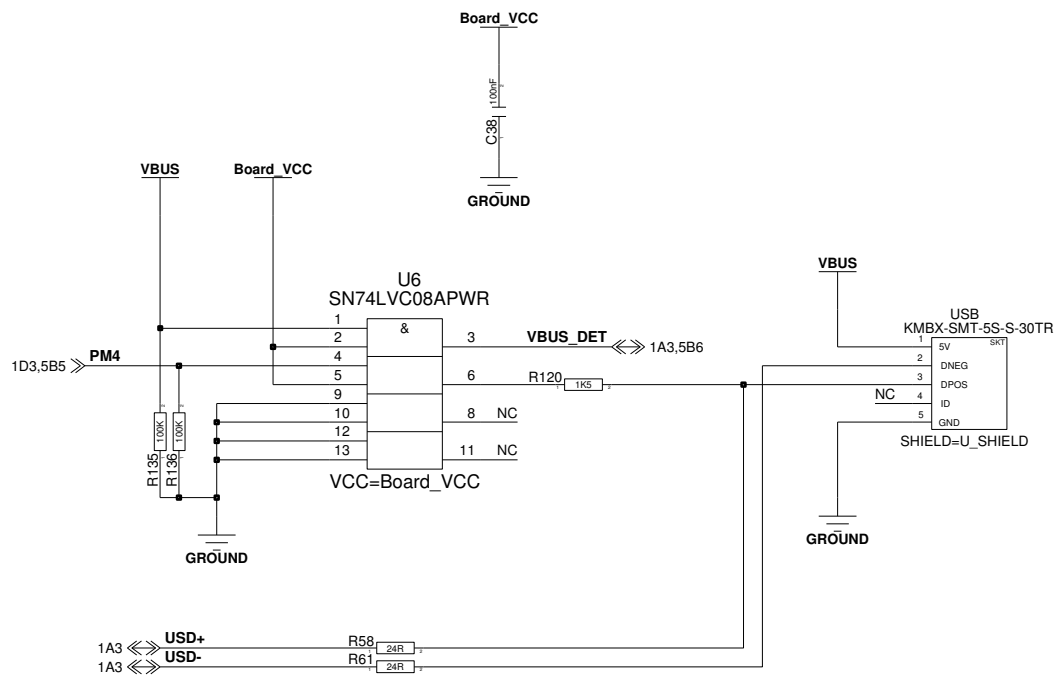

SIZE A4

RENESAS TECHNOLOGY EUROPE LTD
 Dukas Meadow, Bourne End, Buckinghamshire
 UNITED KINGDOM

SCHEMATIC TITLE
RSKH8SX1664 & RSKH8SX1668

SHEET TITLE
USB

DRAWN BY	DATE	REV	DRAWING NUMBER	PAGE
VNA	09-01-08	3	D006152_04	6/6