

To our customers,

Old Company Name in Catalogs and Other Documents

On April 1st, 2010, NEC Electronics Corporation merged with Renesas Technology Corporation, and Renesas Electronics Corporation took over all the business of both companies. Therefore, although the old company name remains in this document, it is a valid Renesas Electronics document. We appreciate your understanding.

Renesas Electronics website: <http://www.renesas.com>

April 1st, 2010
Renesas Electronics Corporation

Issued by: Renesas Electronics Corporation (<http://www.renesas.com>)

Send any inquiries to <http://www.renesas.com/inquiry>.

Notice

1. All information included in this document is current as of the date this document is issued. Such information, however, is subject to change without any prior notice. Before purchasing or using any Renesas Electronics products listed herein, please confirm the latest product information with a Renesas Electronics sales office. Also, please pay regular and careful attention to additional and different information to be disclosed by Renesas Electronics such as that disclosed through our website.
2. Renesas Electronics does not assume any liability for infringement of patents, copyrights, or other intellectual property rights of third parties by or arising from the use of Renesas Electronics products or technical information described in this document. No license, express, implied or otherwise, is granted hereby under any patents, copyrights or other intellectual property rights of Renesas Electronics or others.
3. You should not alter, modify, copy, or otherwise misappropriate any Renesas Electronics product, whether in whole or in part.
4. Descriptions of circuits, software and other related information in this document are provided only to illustrate the operation of semiconductor products and application examples. You are fully responsible for the incorporation of these circuits, software, and information in the design of your equipment. Renesas Electronics assumes no responsibility for any losses incurred by you or third parties arising from the use of these circuits, software, or information.
5. When exporting the products or technology described in this document, you should comply with the applicable export control laws and regulations and follow the procedures required by such laws and regulations. You should not use Renesas Electronics products or the technology described in this document for any purpose relating to military applications or use by the military, including but not limited to the development of weapons of mass destruction. Renesas Electronics products and technology may not be used for or incorporated into any products or systems whose manufacture, use, or sale is prohibited under any applicable domestic or foreign laws or regulations.
6. Renesas Electronics has used reasonable care in preparing the information included in this document, but Renesas Electronics does not warrant that such information is error free. Renesas Electronics assumes no liability whatsoever for any damages incurred by you resulting from errors in or omissions from the information included herein.
7. Renesas Electronics products are classified according to the following three quality grades: "Standard", "High Quality", and "Specific". The recommended applications for each Renesas Electronics product depends on the product's quality grade, as indicated below. You must check the quality grade of each Renesas Electronics product before using it in a particular application. You may not use any Renesas Electronics product for any application categorized as "Specific" without the prior written consent of Renesas Electronics. Further, you may not use any Renesas Electronics product for any application for which it is not intended without the prior written consent of Renesas Electronics. Renesas Electronics shall not be in any way liable for any damages or losses incurred by you or third parties arising from the use of any Renesas Electronics product for an application categorized as "Specific" or for which the product is not intended where you have failed to obtain the prior written consent of Renesas Electronics. The quality grade of each Renesas Electronics product is "Standard" unless otherwise expressly specified in a Renesas Electronics data sheets or data books, etc.

"Standard": Computers; office equipment; communications equipment; test and measurement equipment; audio and visual equipment; home electronic appliances; machine tools; personal electronic equipment; and industrial robots.

"High Quality": Transportation equipment (automobiles, trains, ships, etc.); traffic control systems; anti-disaster systems; anti-crime systems; safety equipment; and medical equipment not specifically designed for life support.

"Specific": Aircraft; aerospace equipment; submersible repeaters; nuclear reactor control systems; medical equipment or systems for life support (e.g. artificial life support devices or systems), surgical implantations, or healthcare intervention (e.g. excision, etc.), and any other applications or purposes that pose a direct threat to human life.

8. You should use the Renesas Electronics products described in this document within the range specified by Renesas Electronics, especially with respect to the maximum rating, operating supply voltage range, movement power voltage range, heat radiation characteristics, installation and other product characteristics. Renesas Electronics shall have no liability for malfunctions or damages arising out of the use of Renesas Electronics products beyond such specified ranges.
9. Although Renesas Electronics endeavors to improve the quality and reliability of its products, semiconductor products have specific characteristics such as the occurrence of failure at a certain rate and malfunctions under certain use conditions. Further, Renesas Electronics products are not subject to radiation resistance design. Please be sure to implement safety measures to guard them against the possibility of physical injury, and injury or damage caused by fire in the event of the failure of a Renesas Electronics product, such as safety design for hardware and software including but not limited to redundancy, fire control and malfunction prevention, appropriate treatment for aging degradation or any other appropriate measures. Because the evaluation of microcomputer software alone is very difficult, please evaluate the safety of the final products or system manufactured by you.
10. Please contact a Renesas Electronics sales office for details as to environmental matters such as the environmental compatibility of each Renesas Electronics product. Please use Renesas Electronics products in compliance with all applicable laws and regulations that regulate the inclusion or use of controlled substances, including without limitation, the EU RoHS Directive. Renesas Electronics assumes no liability for damages or losses occurring as a result of your noncompliance with applicable laws and regulations.
11. This document may not be reproduced or duplicated, in any form, in whole or in part, without prior written consent of Renesas Electronics.
12. Please contact a Renesas Electronics sales office if you have any questions regarding the information contained in this document or Renesas Electronics products, or if you have any other inquiries.

(Note 1) "Renesas Electronics" as used in this document means Renesas Electronics Corporation and also includes its majority-owned subsidiaries.

(Note 2) "Renesas Electronics product(s)" means any product developed or manufactured by or for Renesas Electronics.

SuperH™ Family E10A-USB Emulator

Additional Document for User's Manual
Supplementary Information on
Using the SH7144F/SH7145F

Renesas Microcomputer Development
Environment System

SuperH™ Family / SH7144 Series

E10A-USB for SH7144F HS7144KCU01HE

Notes regarding these materials

1. This document is provided for reference purposes only so that Renesas customers may select the appropriate Renesas products for their use. Renesas neither makes warranties or representations with respect to the accuracy or completeness of the information contained in this document nor grants any license to any intellectual property rights or any other rights of Renesas or any third party with respect to the information in this document.
2. Renesas shall have no liability for damages or infringement of any intellectual property or other rights arising out of the use of any information in this document, including, but not limited to, product data, diagrams, charts, programs, algorithms, and application circuit examples.
3. You should not use the products or the technology described in this document for the purpose of military applications such as the development of weapons of mass destruction or for the purpose of any other military use. When exporting the products or technology described herein, you should follow the applicable export control laws and regulations, and procedures required by such laws and regulations.
4. All information included in this document such as product data, diagrams, charts, programs, algorithms, and application circuit examples, is current as of the date this document is issued. Such information, however, is subject to change without any prior notice. Before purchasing or using any Renesas products listed in this document, please confirm the latest product information with a Renesas sales office. Also, please pay regular and careful attention to additional and different information to be disclosed by Renesas such as that disclosed through our website. (<http://www.renesas.com>)
5. Renesas has used reasonable care in compiling the information included in this document, but Renesas assumes no liability whatsoever for any damages incurred as a result of errors or omissions in the information included in this document.
6. When using or otherwise relying on the information in this document, you should evaluate the information in light of the total system before deciding about the applicability of such information to the intended application. Renesas makes no representations, warranties or guaranties regarding the suitability of its products for any particular application and specifically disclaims any liability arising out of the application and use of the information in this document or Renesas products.
7. With the exception of products specified by Renesas as suitable for automobile applications, Renesas products are not designed, manufactured or tested for applications or otherwise in systems the failure or malfunction of which may cause a direct threat to human life or create a risk of human injury or which require especially high quality and reliability such as safety systems, or equipment or systems for transportation and traffic, healthcare, combustion control, aerospace and aeronautics, nuclear power, or undersea communication transmission. If you are considering the use of our products for such purposes, please contact a Renesas sales office beforehand. Renesas shall have no liability for damages arising out of the uses set forth above.
8. Notwithstanding the preceding paragraph, you should not use Renesas products for the purposes listed below:
 - (1) artificial life support devices or systems
 - (2) surgical implantations
 - (3) healthcare intervention (e.g., excision, administration of medication, etc.)
 - (4) any other purposes that pose a direct threat to human lifeRenesas shall have no liability for damages arising out of the uses set forth in the above and purchasers who elect to use Renesas products in any of the foregoing applications shall indemnify and hold harmless Renesas Technology Corp., its affiliated companies and their officers, directors, and employees against any and all damages arising out of such applications.
9. You should use the products described herein within the range specified by Renesas, especially with respect to the maximum rating, operating supply voltage range, movement power voltage range, heat radiation characteristics, installation and other product characteristics. Renesas shall have no liability for malfunctions or damages arising out of the use of Renesas products beyond such specified ranges.
10. Although Renesas endeavors to improve the quality and reliability of its products, IC products have specific characteristics such as the occurrence of failure at a certain rate and malfunctions under certain use conditions. Please be sure to implement safety measures to guard against the possibility of physical injury, and injury or damage caused by fire in the event of the failure of a Renesas product, such as safety design for hardware and software including but not limited to redundancy, fire control and malfunction prevention, appropriate treatment for aging degradation or any other applicable measures. Among others, since the evaluation of microcomputer software alone is very difficult, please evaluate the safety of the final products or system manufactured by you.
11. In case Renesas products listed in this document are detached from the products to which the Renesas products are attached or affixed, the risk of accident such as swallowing by infants and small children is very high. You should implement safety measures so that Renesas products may not be easily detached from your products. Renesas shall have no liability for damages arising out of such detachment.
12. This document may not be reproduced or duplicated, in any form, in whole or in part, without prior written approval from Renesas.
13. Please contact a Renesas sales office if you have any questions regarding the information contained in this document, Renesas semiconductor products, or if you have any other inquiries.

Contents

Section 1	Connecting the Emulator with the User System	1
1.1	Components of the Emulator	1
1.2	Connecting the E10A-USB Emulator with the User System	3
1.3	Installing the H-UDI Port Connector on the User System	4
1.4	Pin Assignments of the H-UDI Port Connector	4
1.5	Recommended Circuit between the H-UDI Port Connector and the MCU	7
1.5.1	Recommended Circuit (36-Pin Type)	7
1.5.2	Recommended Circuit (14-Pin Type)	10
Section 2	Specifications of the Software when Using the SH7144F or SH7145F	13
2.1	Differences between the SH7144F or SH7145F and the Emulator	13
2.2	Specific Functions for the Emulator when Using the SH7144F or SH7145F	18
2.2.1	Break Condition Functions	19
2.2.2	AUD Functions	21
2.2.3	Notes on Displaying the [Trace] Window	24
2.2.4	Notes on Using the JTAG Clock (TCK)	24
2.2.5	Notes on Setting the [Breakpoint] Dialog Box	25

Section 1 Connecting the Emulator with the User System

1.1 Components of the Emulator





The E10A-USB emulator supports the SH7144F and SH7145F.

The supported operating modes are as follows:

- MCU expansion mode 2
- Single-chip mode

Table 1.1 lists the components of the emulator.

Table 1.1 Components of the Emulator

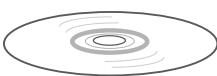
Classification	Component	Appearance	Quantity	Remarks
Hardware	Emulator box		1	HS0005KCU01H: Depth: 65.0 mm, Width: 97.0 mm, Height: 20.0 mm, Mass: 72.9 g or HS0005KCU02H: Depth: 65.0 mm, Width: 97.0 mm, Height: 20.0 mm, Mass: 73.7 g
	User system interface cable		1	14-pin type: Length: 20 cm, Mass: 33.1 g
	User system interface cable		1	36-pin type: Length: 20 cm, Mass: 49.2 g (only for HS0005KCU02H)
	USB cable		1	Length: 150 cm, Mass: 50.6 g
Software	E10A-USB emulator setup program, SuperH™ Family E10A-USB Emulator User's Manual, Supplementary Information on Using the SH7144F/ SH7145F*, and Test program manual for HS0005KCU01H and HS0005KCU02H		1	HS0005KCU01SR, HS0005KCU01HJ, HS0005KCU01HE, HS7144KCU01HJ, HS7144KCU01HE, HS0005TM01HJ, and HS0005TM01HE (provided on a CD-R)

Note: Additional document for the MCUs supported by the emulator is included. Check the target MCU and refer to its additional document.

1.2 Connecting the E10A-USB Emulator with the User System

To connect the E10A-USB emulator (hereinafter referred to as the emulator), the H-UDI port connector must be installed on the user system to connect the user system interface cable. When designing the user system, refer to the recommended circuit between the H-UDI port connector and the MCU. In addition, read the E10A-USB emulator user's manual and hardware manual for the related device.

Table 1.2 shows the type number of the emulator, the corresponding connector type, and the use of AUD function.

Table 1.2 Type Number, AUD Function, and Connector Type

Type Number	Connector	AUD Function
HS0005KCU01H, HS0005KCU02H	14-pin connector	Not available
HS0005KCU02H	36-pin connector	Available

The H-UDI port connector has the 36-pin and 14-pin types as described below. Use them according to the purpose of the usage.

1. 36-pin type (with AUD function)

The AUD trace function is supported. A large amount of trace information can be acquired in realtime. The window trace function is also supported for acquiring memory access in the specified range (memory access address or memory access data) by tracing.

2. 14-pin type (without AUD function)

The AUD trace function cannot be used because only the H-UDI function is supported. For tracing, only the internal trace function is supported. Since the 14-pin type connector is smaller than the 36-pin type (1/2.5), the area where the connector is installed on the user system can be reduced.

1.3 Installing the H-UDI Port Connector on the User System

Table 1.3 shows the recommended H-UDI port connectors for the emulator.

Table 1.3 Recommended H-UDI Port Connectors

Connector	Type Number	Manufacturer	Specifications
36-pin connector	DX10M-36S	Hirose Electric Co., Ltd.	Screw type
	DX10M-36SE, DX10G1M-36SE		Lock-pin type
14-pin connector	2514-6002	Minnesota Mining & Manufacturing Ltd.	14-pin straight type

Note: When designing the 14-pin connector layout on the user board, do not place any components within 3 mm of the H-UDI port connector. When designing the 36-pin connector layout on the user board, do not connect any components under the H-UDI connector.

1.4 Pin Assignments of the H-UDI Port Connector

Figures 1.1 and 1.2 show the pin assignments of the 36-pin and 14-pin H-UDI port connectors, respectively.

Note: Note that the pin number assignments of the H-UDI port connector shown on the following pages differ from those of the connector manufacturer.

Pin No.	Signal	Input/ Output *1	SH7144F Pin No.	SH7145F Pin No.	Note	Pin No.	Signal	Input/ Output *1	SH7144F Pin No.	SH7145F Pin No.	Note
1	AUDCK	I/O	53	65		19	TMS	Input	85	138	
2	GND	—				20	GND	—			
3	AUDATA0	I/O	60	72		21*2	/TRST	Input	86	139	
4	GND	—				22*5	GND	—			
5	AUDATA1	I/O	59	70		23	TDI	Input	87	140	
6	GND	—				24	GND	—			
7	AUDATA2	I/O	58	69		25	TDO	Output	88	142	
8	GND	—				26	GND	—			
9	AUDATA3	I/O	57	68		27*2	/ASEBRKAK	Output	27	35	
10	GND	—				28	GND	—			
11*2	/AUDSYNC	I/O	52	64		29*4	UVCC	Output			
12	GND	—				30	GND	—			
13*2	/AUDRST	Input	56	67		31*2	/RES	Output	84	108	User reset
14	GND	—				32	GND	—			
15	AUDMD	Input	54	66		33*3	GND	Output			
16	GND	—				34	GND	—			
17	TCK	Input	89	143		35	N.C.	—			
18	GND	—				36	GND	—			

Notes: 1. Input to or output from the user system.

2. The slash (/) means that the signal is active-low.

3. The emulator monitors the GND signal of the user system and detects whether or not the user system is connected.

4. If the VccQ pin is not connected to the UVCC, the I/O voltage of the user system interface will be fixed to 3.3 V.

5. Note that the processing of the DBGMD pin (SH7144F: pin 33, SH7145F: pin 42) differs depending on whether or not the emulator is used. In addition, the DBGMD pin must be switched on the board because it is not controlled by the emulator.

(1) When the emulator is used: DBGMD = 1 (ASE mode)

(2) When the emulator is not used: DBGMD = 0 (normal mode)

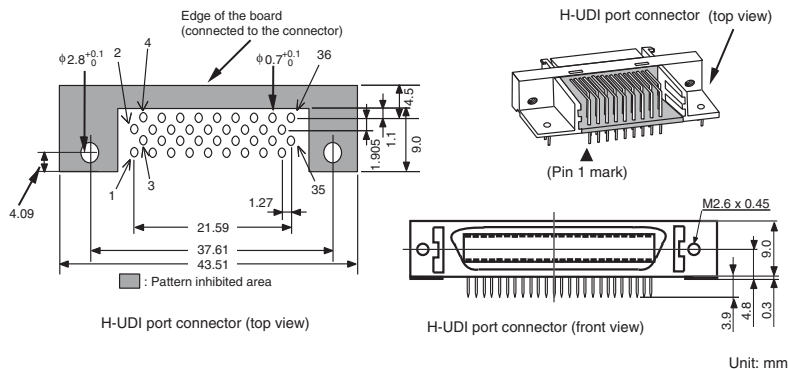

Figure 1.1 Pin Assignments of the H-UDI Port Connector (36 Pins)

Limitation:

The AUD pins of the SH7145F are also multiplexed to port E. However, do not use those pins when the AUD function is used by the emulator. The correct address or data will not be accessed.

Pin No.	Signal	Input/ Output*1	SH7144F Pin No.	SH7145F Pin No.
1	TCK	Input	89	143
2*2	/TRST	Input	86	139
3	TDO	Output	88	142
4*2	/ASEBRKAK	Output	27	35
5	TMS	Input	85	138
6	TDI	Input	87	140
7*2	/RES	Output	84	108
8*6	N.C.			
9*5	(GND)			
11*4	UVCC	—	—	—
10, 12, and 13	GND	—	—	—
14*3	GND	Output	—	—

- Notes: 1. Input to or output from the user system.
2. The slash (/) means that the signal is active-low.
3. The emulator monitors the GND signal of the user system and detects whether or not the user system is connected.
4. If the VccQ pin is not connected to the UVCC, the I/O voltage of the user system interface will be fixed to 3.3 V.
5. Note that the processing of the DBGMD pin (SH7144F: pin 33, SH7145F: pin 42) differs depending on whether or not the emulator is used. In addition, the DBGMD pin must be switched on the board because it is not controlled by the emulator.
(1) When the emulator is used: DBGMD = 1 (ASE mode)
(2) When the emulator is not used: DBGMD = 0 (normal mode)
6. This pin can be connected to GND.

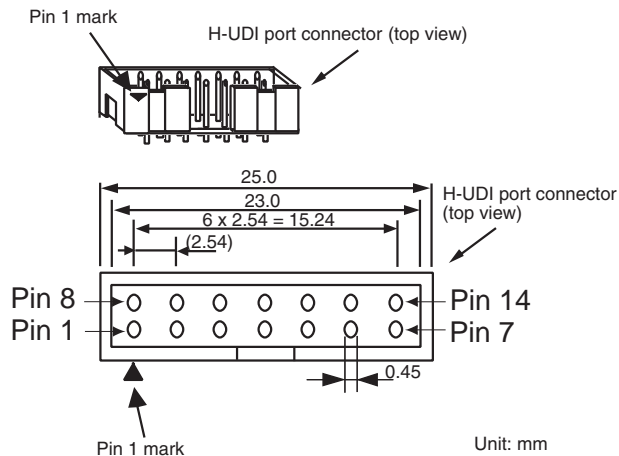

Figure 1.2 Pin Assignments of the H-UDI Port Connector (14 Pins)

1.5 Recommended Circuit between the H-UDI Port Connector and the MCU

1.5.1 Recommended Circuit (36-Pin Type)

Figure 1.3 shows a recommended circuit for connection between the H-UDI and AUD port connectors (36 pins) and the MCU when the emulator is in use. Figure 1.4 shows a circuit for connection when UVCC is not connected.

- Notes:
1. Do not connect anything to the N.C. pins of the H-UDI port connector.
 2. Note that the processing of the DBGMD pin (SH7144F: pin 33, SH7145F: pin 42) differs depending on whether or not the emulator is used. In addition, the DBGMD pin must be switched on the board because it is not controlled by the emulator.
 - (1) When the emulator is used: $\text{DBGMD} = 1$ (ASE mode)
 - (2) When the emulator is not used: $\text{DBGMD} = 0$ (normal mode)
 3. When a network resistance is used for pull-up, it may be affected by a noise. Separate TCK from other resistances.
 4. When the emulator is used, the AUDCK pin must be an end resistance (pulled up or down by a resistance of several kilo-ohms) because it may be affected by a reflected noise from the user system interface cable.
 5. The pattern between the H-UDI port connector and the MCU must be as short as possible. Do not connect the signal lines to other components on the board.
 6. When the power supply of the user system is turned off, supplying VccQ of the user system to the UVCC pin reduces the leakage current from the emulator to the user system. Buffers that can be activated by the internal power supply or user power supply (changed by the switch) are installed in the interface circuit of the emulator. If the user power is selected for supply to the UVCC pin, the buffers will not be activated unless supplied with user power. Thus no current flows from the user interface when the power supply of the user system is turned off. The I/O voltage level of the user system interface can be the same as that of the VccQ. To operate the emulator with low voltage (lower than 3.3 V), the VccQ must be supplied to the UVCC pin. Make the emulator's switch settings so that the VccQ will be supplied ($\text{SW2} = 1$ and $\text{SW3} = 1$) (as shown in figure 1.3).
 7. The resistance values shown in figures 1.3 and 1.4 are recommended.
 8. For the pin processing in cases where the emulator is not used, refer to the hardware manual of the related MCU.

When the circuit is connected as shown in figure 1.3, the switches of the emulator are set as SW2 = 1 and SW3 = 1. For details, refer to section 3.8, Setting the DIP Switches, in the SuperH™ Family E10A-USB Emulator User's Manual.

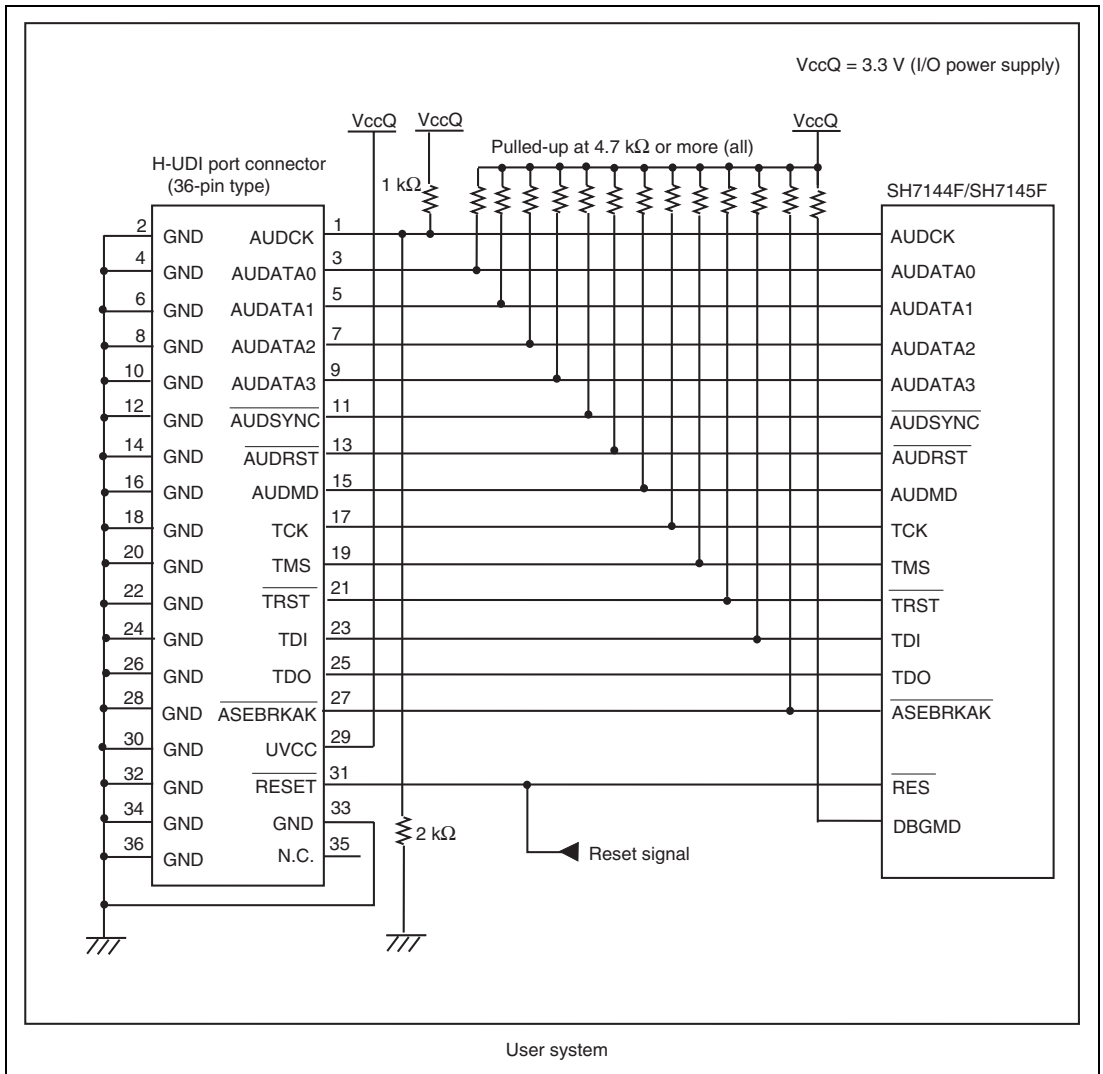

Figure 1.3 Recommended Circuit for Connection between the H-UDI Port Connector and MCU when the Emulator is in Use (36-Pin Type UVCC Connected)

When the circuit is connected as shown in figure 1.4, the switches of the emulator are set as SW2 = 0 and SW3 = 1. For details, refer to section 3.8, Setting the DIP Switches, in the SuperH™ Family E10A-USB Emulator User's Manual.

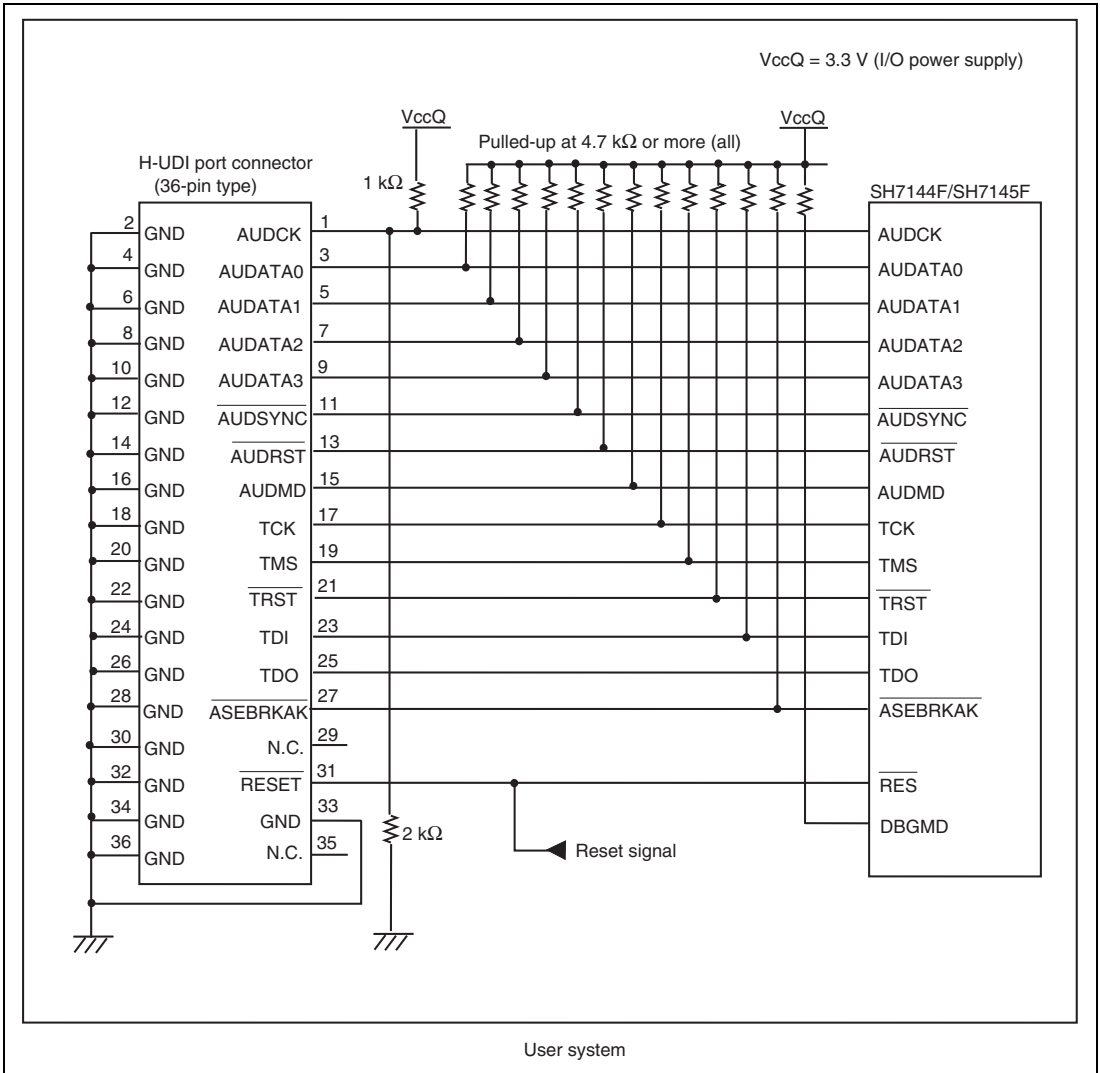

Figure 1.4 Circuit for Connection between the H-UDI Port Connector and MCU when the Emulator is in Use (36-Pin Type UVCC Not Connected*)

Note: When UVCC is not connected and the user system is turned off, note that the leakage current flows from the emulator to the user system.

1.5.2 Recommended Circuit (14-Pin Type)

Figure 1.5 shows a recommended circuit for connection between the H-UDI and AUD port connectors (14 pins) and the MCU when the emulator is in use. Figure 1.6 shows a circuit for connection when UVCC is not connected.

- Notes:
1. Do not connect anything to the N.C. pins of the H-UDI port connector.
 2. Note that the processing of the DBGMD pin (SH7144F: pin 33, SH7145F: pin 42) differs depending on whether or not the emulator is used. In addition, the DBGMD pin must be switched on the board because it is not controlled by the emulator.
 - (1) When the emulator is used: $\text{DBGMD} = 1$ (ASE mode)
 - (2) When the emulator is not used: $\text{DBGMD} = 0$ (normal mode)
 3. When a network resistance is used for pull-up, it may be affected by a noise. Separate TCK from other resistances.
 4. The pattern between the H-UDI port connector and the MCU must be as short as possible. Do not connect the signal lines to other components on the board.
 5. When the power supply of the user system is turned off, supplying V_{ccQ} of the user system to the UVCC pin reduces the leakage current from the emulator to the user system. A level shifter that is activated by the internal power supply or user power supply (changed by the switch) is installed in the interface circuit of the emulator. If the user power is supplied to the UVCC pin, the level shifter is not activated as long as no user power is supplied. When the power supply of the user system is turned off, no current flows from the user interface. The I/O voltage level of the user system interface can be the same as that of the V_{ccQ} . To operate the emulator with low voltage (lower than 3.3 V), the V_{ccQ} must be supplied to the UVCC pin. Make the emulator's switch settings so that the V_{ccQ} will be supplied ($\text{SW2} = 1$ and $\text{SW3} = 1$) (as shown in figure 1.5).
 6. The resistance values shown in figures 1.5 and 1.6 are recommended.
 7. For the pin processing in cases where the emulator is not used, refer to the hardware manual of the related MCU.

When the circuit is connected as shown in figure 1.5, the switches of the emulator are set as SW2 = 1 and SW3 = 1. For details, refer to section 3.8, Setting the DIP Switches, in the SuperH™ Family E10A-USB Emulator User's Manual.

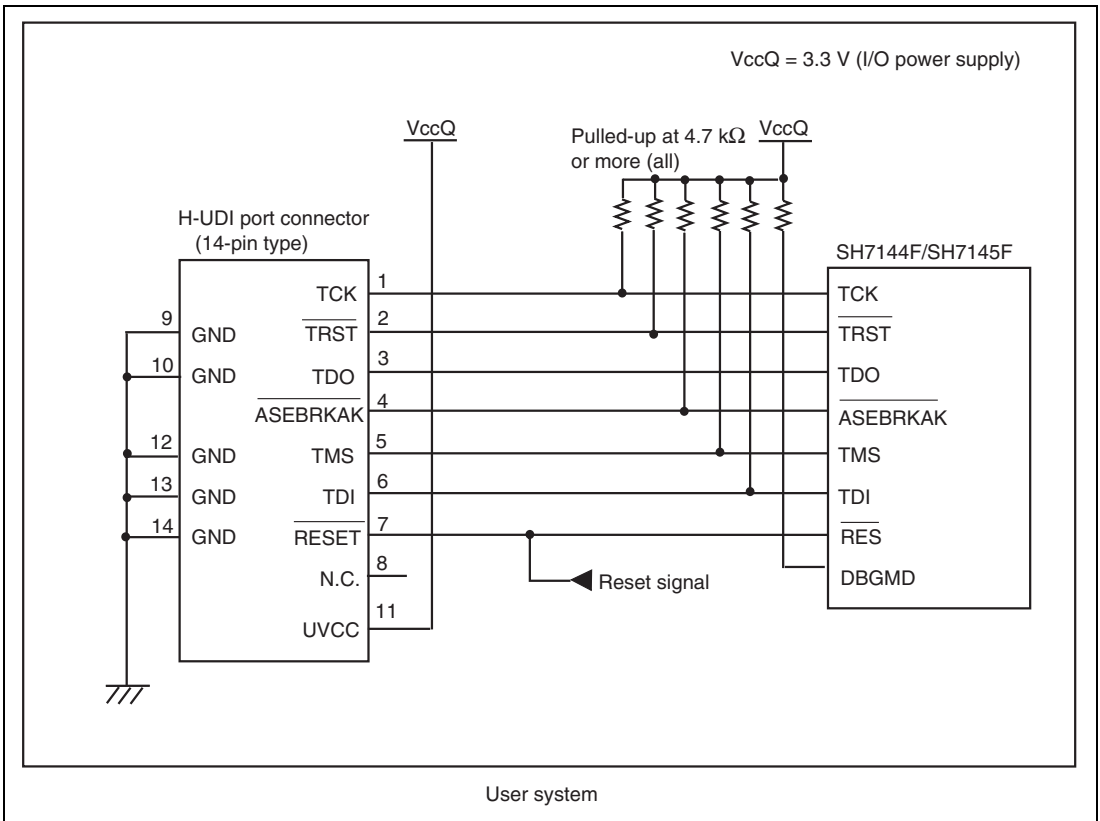

Figure 1.5 Recommended Circuit for Connection between the H-UDI Port Connector and MCU when the Emulator is in Use (14-Pin Type UVCC Connected)

When the circuit is connected as shown in figure 1.6, the switches of the emulator are set as SW2 = 0 and SW3 = 1. For details, refer to section 3.8, Setting the DIP Switches, in the SuperH™ Family E10A-USB Emulator User's Manual.

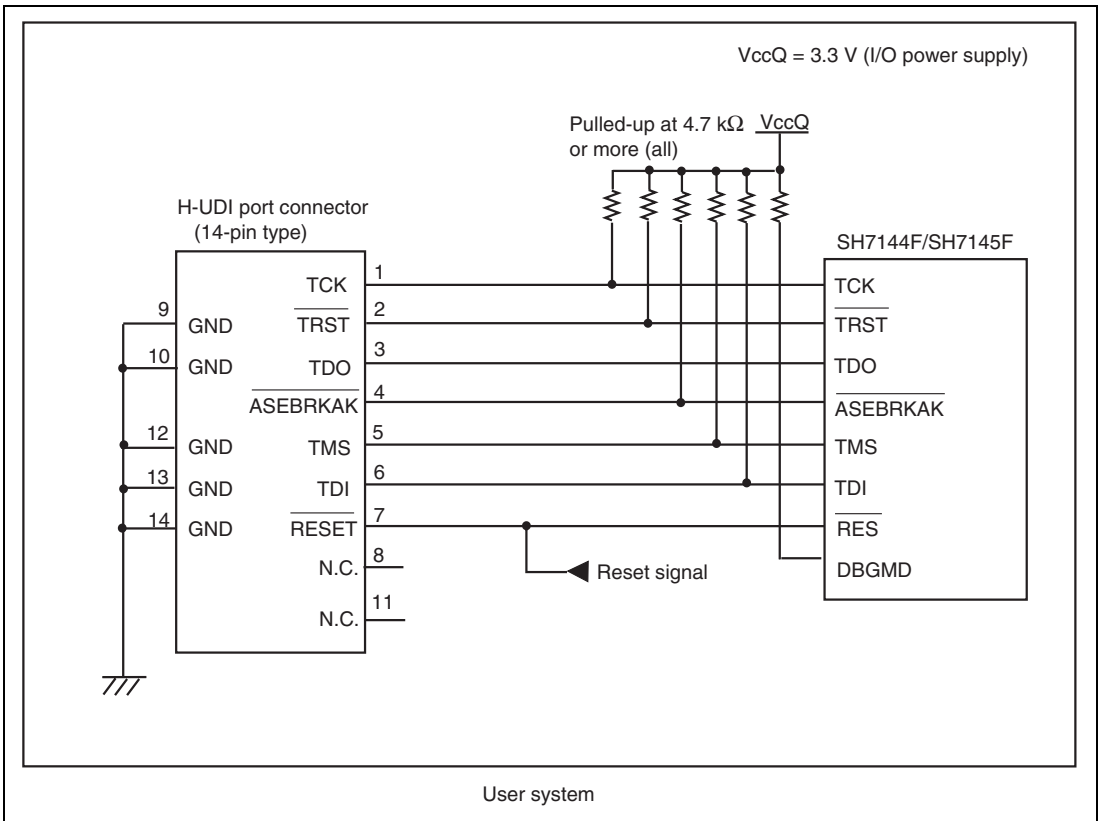

Figure 1.6 Circuit for Connection between the H-UDI Port Connector and MCU when the Emulator is in Use (14-Pin Type UVCC Not Connected*)

Note: When UVCC is not connected and the user system is turned off, note that the leakage current flows from the emulator to the user system.

Section 2 Specifications of the Software when Using the SH7144F or SH7145F

2.1 Differences between the SH7144F or SH7145F and the Emulator

1. When the emulator system is initiated, it initializes the general registers and part of the control registers as shown in table 2.1. The initial values of the actual SH7144F or SH7145F registers are undefined. When the emulator is initiated from the workspace, a value to be entered is saved in a session.

Table 2.1 Register Initial Values at Emulator Link Up

Register	Emulator at Link Up
R0 to R14	H'00000000
R15 (SP)	Value of the SP in the vector address table
PC	Value of the PC in the vector address table
SR	H'000000F0
GBR	H'00000000
VBR	H'00000000
MACH	H'00000000
MACL	H'00000000
PR	H'00000000

2. The emulator uses the H-UDI; do not access the H-UDI.

3. Low-Power States (Sleep, Software Standby, and Module Standby)

For low-power consumption, the SH7144F or SH7145 have sleep, software standby, and module standby states.

When the emulator is used, the sleep mode can be cleared with either the normal clearing function or with the forced break. Note that, however, if a command has been entered in software standby mode or module standby mode, no commands can be used from the emulator since the mode is cleared only with the normal clearing function.

Notes: The memory must not be accessed or modified in sleep state.

1. Do not set the MSTP2 or MSTP27 bit to 1 in the MSTCR2 register (address H'FFFF861E) nor the RAME bit to 0 in the SYSCR register (address H'FFFF8618), since doing so may prevent the emulator from operating correctly.
2. When the HS0005KCU02H is used, do not set the following bits to 0: the MSTP3 bit in the MSTCR2 register (address H'FFFF861E) and the AUDSRST bit in the SYSCR register (address H'FFFF8618). The AUD function cannot be used.

4. Reset Signals (/RES)

The RESET signal can be accepted during user program break, when the peripheral modules are reset. Since the PC, SR, and SP registers are not initialized, reset them and execute the GO command when the user program is executed from the reset vector.

Note: Do not break the user program when the RES, BREQ, and WAIT pins are being low. A TIMEOUT error will occur. The TIMEOUT error will also occur at memory access when the BREQ and WAIT pins are fixed low during break.

5. Data Transfer Controller (DTC)

The DTC operates even in the command wait state. When a data transfer request is generated, the DTC executes a DMA transfer.

6. Memory Access during User Program Execution

When a memory is accessed from the memory window, etc. during user program execution, the user program is resumed after it has stopped in the emulator to access the memory. Therefore, realtime emulation cannot be performed.

The stopping time of the user program is as follows:

Environment:

Host computer: 650 MHz (Pentium® III)

OS: Windows® 2000

SH7144F: 50 MHz (CPU clock)

JTAG clock: 10 MHz (TCK clock)

When a one-byte memory is read from the command-line window, the stopping time will be about 35 ms.

7. Memory Access during User Program Break

Memory write operations are enabled for the RAM area and the internal flash memory.

Therefore, an operation such as memory write or BREAKPOINT should be set only for the RAM area and the internal flash memory.

8. Multiplexed Functions

The AUD and H-UDI pins are multiplexed as shown in tables 2.2 and 2.3. Those functions cannot be used when the emulator is used.

Table 2.2 Multiplexed Functions for the SH7144F

Function 1	Function 2
PE0/TIOC0A/DREQ0	TMS (H-UDI)
PE1/TIOC0B/DRAK0	TRST (H-UDI)
PE2/TIOC0C/DREQ1	TDI (H-UDI)
PE3/TIOC0D/DRAK1	TDO (H-UDI)
PE4/TIOC1A/RXD3	TCK (H-UDI)
PD15/D15*	AUDSYNC (AUD)
PD14/D14*	AUDCK (AUD)
PD13/D13*	AUDMD (AUD)
PD12/D12*	AUDRST (AUD)
PD11/D11*	AUDATA3 (AUD)
PD10/D10*	AUDATA2 (AUD)
PD9/D9*	AUDATA1 (AUD)
PD8/D8*	AUDATA0 (AUD)

Note: Function 1 can be used when the AUD pins of the MCU are not connected to the emulator.

Table 2.3 Multiplexed Functions for the SH7145F

Function 1	Function 2
PE9/TIOC3B/SCK3	TRST (H-UDI)
PE8/TIOC3A/SCK2	TMS (H-UDI)
PE11/TIOC3D/RXD3	TDO (H-UDI)
PE10/TIOC3C/TXD2	TDI (H-UDI)
PE12/TIOC4A/TXD3	TCK (H-UDI)
PD23/D23/IRQ7*	AUDSYNC (AUD)
PD22/D22/IRQ6*	AUDCK (AUD)
PD21/D21/IRQ5*	AUDMD (AUD)
PD20/D20/IRQ4*	AUDRST (AUD)
PD19/D19/IRQ3*	AUDATA3 (AUD)
PD18/D18/IRQ2*	AUDATA2 (AUD)
PD17/D17/IRQ1*	AUDATA1 (AUD)
PD16/D16/IRQ0*	AUDATA0 (AUD)

Note: Function 1 can be used when the AUD pins of the MCU are not connected to the emulator. The AUD pins of the SH7145F are also multiplexed to port E. However, do not use those pins when the AUD function is used by the emulator. The correct address or data will not be accessed.

9. Loading Sessions

Information in [JTAG clock] of the [Configuration] dialog box cannot be recovered by loading sessions. Thus the TCK value will be 1.25 MHz.

10. [IO] Window

- Display and modification

For each Watchdog Timer register, there are two registers to be separately used for write and read operations.

Table 2.4 Watchdog Timer Registers

Register Name	Usage	Register
TCSR (R)	Read	Watchdog timer control/status register
TCNT (R)	Read	Watchdog timer counter
RSTCSR (R)	Read	Reset control/status register
TCSR (W)	Write	Watchdog timer control/status register
TCNT (W)	Write	Watchdog timer counter
RSTCSR (W)	Write	Reset control/status register

- The internal I/O registers can be accessed from the [IO] window. After the I/O-register definition file is created, the MCU's specification may be changed. If each I/O register in the I/O-register definition file differs from addresses described in the hardware manual, change the I/O-register definition file according to the description in the hardware manual. The I/O-register definition file can be customized depending on its format. Note that, however, the emulator does not support the bit-field function.
- Verify
In the [IO] window, the verify function of the input value is disabled.

11. Illegal Instructions

If illegal instructions are executed by STEP-type commands, the emulator cannot go to the next program counter.

12. Interrupts

All interrupts except for NMI are masked during user program break.

13. When accessing the reserved memory area, use the [Memory] window; do not use other windows.

14. Processing Time for Updating the Flash Memory Contents

When the contents of the flash memory area is modified by the program loading, memory window, or memory command, or when a software break is set, a waiting time will be generated to write or read the flash memory before executing the user program.

The processing time for updating the flash memory contents will be about a maximum of 60 seconds under the following environments (reference values):

- Host computer: 500 MHz (Pentium® III)
- SH7144F: 40 MHz (system clock frequency)

2.2 Specific Functions for the Emulator when Using the SH7144F or SH7145F

The SH7144F or SH7145F does not support the following functions:

- MMU-related functions (The SH7144F or SH7145F does not mount the MMU.)
 - VPMAP-related command
 - Virtual and Physical specification in the [Configuration] window
 - Virtual and Physical specification on the command-line function
 - Virtual and Physical specification in the [Breakpoint] window
 - LDTLB instruction execution break function
 - MEMORYAREA_SET command
- Internal I/O access break function
- UBC_MODE command (The UBC function cannot be used while the emulator is being used.)
- UBC_MODE specification in the [Configuration] window or the command-line function
- Profiling function
- Performance measurement function

2.2.1 Break Condition Functions

The emulator can set conditions of Break Condition. Table 2.5 lists these conditions.

Table 2.5 Types of Break Conditions

Items	Description
Address bus condition (Address)	Breaks when the MCU address bus value or program counter value matches the specified value.
Data size condition (Size)	Breaks when the data size that has been accessed matches the specified value. Byte, word, or longword can be specified as the access data size.
Read or write condition (Read or Write)	Breaks in the read or write cycle.
Access type	Breaks when the bus cycle is the specified cycle.

Table 2.6 lists the combinations of conditions that can be set in the [Break Condition] dialog box.

Table 2.6 Conditions Set in the [Break Condition] Dialog Box

Dialog Box	Type	
	Address Bus Condition ([Address] page)	Access Type Condition, Read or Write Condition, Data Size Condition ([Bus state] page)
[Break Condition 1] dialog box	<input type="radio"/>	<input type="radio"/>
[Break Condition 2] dialog box	<input type="radio"/>	<input type="radio"/>
[Break Condition 3] dialog box	<input type="radio"/>	<input type="radio"/>
[Break Condition 4] dialog box	<input type="radio"/>	<input type="radio"/>
[Break Condition R] dialog box	<input type="radio"/>	-

Note: : Can be set by clicking the radio button in the dialog box.

Table 2.7 lists the combinations of conditions that can be set with the BREAKCONDITION_SET command.

Table 2.7 Conditions Set with the BREAKCONDITION_SET Command

Channel	Type	
	Address Bus Condition (<addropt> option)	Access Type Condition (<accessopt> option), Read or Write Condition (<r/wopt> option), Data Size Condition (<sizeopt> option)
Break Condition 1	O	O
Break Condition 2	O	O
Break Condition 3	O	O
Break Condition 4	O	O
Break Condition R	O	-

Note: O: Can be set by the BREAKCONDITION_SET command.

Notes on Setting the [Break Condition] Dialog Box and BREAKCONDITION_SET Command:

1. When [Go to cursor], [Step In], [Step Over], or [Step Out] is selected, the settings of Break Condition 3 are disabled.
2. Break Condition 3 is disabled when an instruction to which a BREAKPOINT has been set is executed. Accordingly, do not set a BREAKPOINT to an instruction which satisfies Break Condition 3.
3. When a Break Condition is satisfied, emulation may stop after two or more instructions have been executed.
4. If a PC break before execution is set to the slot instruction after a delayed branch instruction, user program execution cannot be terminated before the slot instruction execution; execution stops before the branch destination instruction.

2.2.2 AUD Functions

In the emulator, the functions listed in table 2.8 using the AUD function can be used. These functions are operational when the AUD pin is connected to the emulator.

To enable the AUD function, select [Options -> Emulator -> System...] or set [AUD used] in the [AUD Port] combo box of the [Configuration] dialog box that is opened by clicking the [Emulator System] toolbar button .

Note: Select [AUD used] and set the following before using the AUD function in the user program. The AUD function does not operate correctly until the following is set after user program execution is started:

- Set 1 to the AUDSRST bit in the SYSCR register and cancel the AUD reset.
- Set the pin function controller to enable the AUD input/output pins (/AUDSYNC, AUDCK, AUDMD, /AUDRST, AUDATA3, AUDATA2, AUDATA1, and AUDATA0).

Table 2.8 AUD Functions

Function	Description
Branch trace function	Displays the addresses and instruction words at the branch destination.
RAM monitor function	Enables realtime memory reading or writing during user program execution.

- Notes:
1. When HS0005KCU01H is used, the AUD function cannot be used.
 2. When the MCU operating mode is MCU expansion mode 2, the AUD function cannot be used.

Limitation:

The AUD pins of the SH7145F are multiplexed to ports D and E. However, do not use those pins that are multiplexed to port E when the AUD function is used by the emulator. The correct address or data will not be accessed.

(1) Branch Trace Function

When a branch occurs during user program execution, the branch destination address is acquired. When the next branch occurs while the trace information is being output, the information is stopped and the next trace information is output. The user program can be executed in realtime, but some trace information will not be output.

Note: After [Trace stop] is selected in [AUD mode] of the [Trace mode] page in the [Trace Acquisition] dialog box and the trace buffer of the emulator becomes full, the trace information is not acquired. The user program is continuously executed.

(2) Realtime Memory Access Function

Realtime memory reading or writing is enabled during user program execution. The specified memory address contents (maximum three) can be displayed on the status bar. The memory contents can be changed by the command line, and can be referenced in the [Memory] window.

Memory can be read or written as follows:

1. When the [Memory] window is used:

Memory can be read or written during user program execution. Open the address to be referenced in the [Memory] window. At reference, select Refresh from the [Memory] menu or issue the Refresh command in the command-line window.

2. When the command line is used:

MEMORY_EDIT command: Memory can be read or written during user program execution.

RAM_R command: Address and size displayed on the status bar are specified during user program execution.

RAM_W command: Memory can be changed during user program execution. One command can change a maximum of three addresses.

Note: Note that the flash memory area cannot be written by the RAM_W command.

(3) Products Using the AUD Function and Note

Table 2.9 Type Number and AUD Function

Type Number	Connector	AUD Function
HS0005KCU01H, HS0005KCU02H	14-pin connector	Not available
HS0005KCU02H	36-pin connector	Available

Note: Trace cannot be acquired while memory read/write is being performed by using the RAM monitor function during user program execution.

2.2.3 Notes on Displaying the [Trace] Window

1. The AUD trace outputs the differences between newly output branch destination addresses and the previously output branch destination addresses. If the previous branch destination address is the same as the upper 16 bits, the lower 16 bits are output. If it matches the upper 24 bits, the lower 8 bits are output. If it matches the upper 28 bits, the lower 4 bits are output. The emulator regenerates the 32-bit address from these differences and usually displays it in the [Trace] window. If the emulator cannot display the 32-bit address, it displays the difference from the previously displayed 32-bit address.
2. When a completion-type exception occurs during exception branch acquisition, the next address to the address in which an exception occurs is acquired.
3. When the [Halt] option is used from the popup menu in the [Trace] window, realtime emulation is retained.
4. In the emulator, the maximum number of trace display pointers is 65535 lines (32767 branches).
However, the maximum number of trace display pointers differs according to the AUD trace information to be output. Therefore, the above pointers cannot be always acquired.
5. When only one line is acquired by trace, the display data is not updated. In this case, open the [Trace] window again.

2.2.4 Notes on Using the JTAG Clock (TCK)

1. When the JTAG clock (TCK) is used, set the frequency to lower than that of the system clock.
2. Do not set 20 MHz for the JTAG clock (TCK).

2.2.5 Notes on Setting the [Breakpoint] Dialog Box

1. When an odd address is set, the address is rounded down to an even address.
2. A BREAKPOINT is accomplished by replacing instructions. Accordingly, it can be set only to the RAM area and the internal flash memory. However, a BREAKPOINT cannot be set to the following addresses:
 - An area other than the CS0, internal RAM, and internal flash memory areas
 - An instruction in which Break Condition 3 is satisfied
 - A slot instruction of a delayed branch instruction
3. During step execution, BREAKPOINTS are disabled.
4. Break Condition 3 is disabled when an instruction to which a BREAKPOINT has been set is executed. Accordingly, do not set a BREAKPOINT to an instruction which satisfies Break Condition 3.
5. When execution resumes from the address where a BREAKPOINT is specified, single-step operation is performed at the address before execution resumes. Therefore, realtime operation cannot be performed.
6. When a BREAKPOINT is set to the slot instruction of a delayed branch instruction, the PC value becomes an illegal value. Accordingly, do not set a BREAKPOINT to the slot instruction of a delayed branch instruction.
7. If an address of a BREAKPOINT cannot be correctly set in the ROM or flash memory area, a mark ● will be displayed in the [BP] area of the address on the [Editor] or [Disassembly] window by refreshing the [Memory] window, etc. after Go execution. However, no break will occur at this address. When the program halts with the break condition, the mark ● disappears.

**SuperH™ Family E10A-USB Emulator
Additional Document for User's Manual
Supplementary Information on Using the SH7144F/SH7145F**

Publication Date: Rev.1.00, August 25, 2004
Rev.2.00, March 19, 2007

Published by: Sales Strategic Planning Div.
Renesas Technology Corp.

Edited by: Customer Support Department
Global Strategic Communication Div.
Renesas Solutions Corp.

Renesas Technology Corp. Sales Strategic Planning Div. Nippon Bldg., 2-6-2, Ohte-machi, Chiyoda-ku, Tokyo 100-0004, Japan



RENESAS SALES OFFICES

<http://www.renesas.com>

Refer to "<http://www.renesas.com/en/network>" for the latest and detailed information.

Renesas Technology America, Inc.

450 Holger Way, San Jose, CA 95134-1368, U.S.A
Tel: <1> (408) 382-7500, Fax: <1> (408) 382-7501

Renesas Technology Europe Limited

Dukes Meadow, Millboard Road, Bourne End, Buckinghamshire, SL8 5FH, U.K.
Tel: <44> (1628) 585-100, Fax: <44> (1628) 585-900

Renesas Technology (Shanghai) Co., Ltd.

Unit 204, 205, AZIACenter, No.1233 Lujiazui Ring Rd, Pudong District, Shanghai, China 200120
Tel: <86> (21) 5877-1818, Fax: <86> (21) 6887-7898

Renesas Technology Hong Kong Ltd.

7th Floor, North Tower, World Finance Centre, Harbour City, 1 Canton Road, Tsimshatsui, Kowloon, Hong Kong
Tel: <852> 2265-6688, Fax: <852> 2730-6071

Renesas Technology Taiwan Co., Ltd.

10th Floor, No.99, Fushing North Road, Taipei, Taiwan
Tel: <886> (2) 2715-2888, Fax: <886> (2) 2713-2999

Renesas Technology Singapore Pte. Ltd.

1 Harbour Front Avenue, #06-10, Keppel Bay Tower, Singapore 098632
Tel: <65> 6213-0200, Fax: <65> 6278-8001

Renesas Technology Korea Co., Ltd.

Kukje Center Bldg. 18th Fl., 191, 2-ka, Hangang-ro, Yongsan-ku, Seoul 140-702, Korea
Tel: <82> (2) 796-3115, Fax: <82> (2) 796-2145

Renesas Technology Malaysia Sdn. Bhd

Unit 906, Block B, Menara Amcorp, Amcorp Trade Centre, No.18, Jalan Persiaran Barat, 46050 Petaling Jaya, Selangor Darul Ehsan, Malaysia
Tel: <603> 7955-9390, Fax: <603> 7955-9510

**SuperH™ Family E10A-USB Emulator
Additional Document for User's Manual
Supplementary Information on
Using the SH7144F/SH7145F**



Renesas Electronics Corporation

1753, Shimonumabe, Nakahara-ku, Kawasaki-shi, Kanagawa 211-8668 Japan

REJ10B0150-0200