

To our customers,

Old Company Name in Catalogs and Other Documents

On April 1st, 2010, NEC Electronics Corporation merged with Renesas Technology Corporation, and Renesas Electronics Corporation took over all the business of both companies. Therefore, although the old company name remains in this document, it is a valid Renesas Electronics document. We appreciate your understanding.

Renesas Electronics website: <http://www.renesas.com>

April 1st, 2010
Renesas Electronics Corporation

Issued by: Renesas Electronics Corporation (<http://www.renesas.com>)

Send any inquiries to <http://www.renesas.com/inquiry>.

Notice

1. All information included in this document is current as of the date this document is issued. Such information, however, is subject to change without any prior notice. Before purchasing or using any Renesas Electronics products listed herein, please confirm the latest product information with a Renesas Electronics sales office. Also, please pay regular and careful attention to additional and different information to be disclosed by Renesas Electronics such as that disclosed through our website.
2. Renesas Electronics does not assume any liability for infringement of patents, copyrights, or other intellectual property rights of third parties by or arising from the use of Renesas Electronics products or technical information described in this document. No license, express, implied or otherwise, is granted hereby under any patents, copyrights or other intellectual property rights of Renesas Electronics or others.
3. You should not alter, modify, copy, or otherwise misappropriate any Renesas Electronics product, whether in whole or in part.
4. Descriptions of circuits, software and other related information in this document are provided only to illustrate the operation of semiconductor products and application examples. You are fully responsible for the incorporation of these circuits, software, and information in the design of your equipment. Renesas Electronics assumes no responsibility for any losses incurred by you or third parties arising from the use of these circuits, software, or information.
5. When exporting the products or technology described in this document, you should comply with the applicable export control laws and regulations and follow the procedures required by such laws and regulations. You should not use Renesas Electronics products or the technology described in this document for any purpose relating to military applications or use by the military, including but not limited to the development of weapons of mass destruction. Renesas Electronics products and technology may not be used for or incorporated into any products or systems whose manufacture, use, or sale is prohibited under any applicable domestic or foreign laws or regulations.
6. Renesas Electronics has used reasonable care in preparing the information included in this document, but Renesas Electronics does not warrant that such information is error free. Renesas Electronics assumes no liability whatsoever for any damages incurred by you resulting from errors in or omissions from the information included herein.
7. Renesas Electronics products are classified according to the following three quality grades: “Standard”, “High Quality”, and “Specific”. The recommended applications for each Renesas Electronics product depends on the product’s quality grade, as indicated below. You must check the quality grade of each Renesas Electronics product before using it in a particular application. You may not use any Renesas Electronics product for any application categorized as “Specific” without the prior written consent of Renesas Electronics. Further, you may not use any Renesas Electronics product for any application for which it is not intended without the prior written consent of Renesas Electronics. Renesas Electronics shall not be in any way liable for any damages or losses incurred by you or third parties arising from the use of any Renesas Electronics product for an application categorized as “Specific” or for which the product is not intended where you have failed to obtain the prior written consent of Renesas Electronics. The quality grade of each Renesas Electronics product is “Standard” unless otherwise expressly specified in a Renesas Electronics data sheets or data books, etc.
 - “Standard”: Computers; office equipment; communications equipment; test and measurement equipment; audio and visual equipment; home electronic appliances; machine tools; personal electronic equipment; and industrial robots.
 - “High Quality”: Transportation equipment (automobiles, trains, ships, etc.); traffic control systems; anti-disaster systems; anti-crime systems; safety equipment; and medical equipment not specifically designed for life support.
 - “Specific”: Aircraft; aerospace equipment; submersible repeaters; nuclear reactor control systems; medical equipment or systems for life support (e.g. artificial life support devices or systems), surgical implantations, or healthcare intervention (e.g. excision, etc.), and any other applications or purposes that pose a direct threat to human life.
8. You should use the Renesas Electronics products described in this document within the range specified by Renesas Electronics, especially with respect to the maximum rating, operating supply voltage range, movement power voltage range, heat radiation characteristics, installation and other product characteristics. Renesas Electronics shall have no liability for malfunctions or damages arising out of the use of Renesas Electronics products beyond such specified ranges.
9. Although Renesas Electronics endeavors to improve the quality and reliability of its products, semiconductor products have specific characteristics such as the occurrence of failure at a certain rate and malfunctions under certain use conditions. Further, Renesas Electronics products are not subject to radiation resistance design. Please be sure to implement safety measures to guard them against the possibility of physical injury, and injury or damage caused by fire in the event of the failure of a Renesas Electronics product, such as safety design for hardware and software including but not limited to redundancy, fire control and malfunction prevention, appropriate treatment for aging degradation or any other appropriate measures. Because the evaluation of microcomputer software alone is very difficult, please evaluate the safety of the final products or system manufactured by you.
10. Please contact a Renesas Electronics sales office for details as to environmental matters such as the environmental compatibility of each Renesas Electronics product. Please use Renesas Electronics products in compliance with all applicable laws and regulations that regulate the inclusion or use of controlled substances, including without limitation, the EU RoHS Directive. Renesas Electronics assumes no liability for damages or losses occurring as a result of your noncompliance with applicable laws and regulations.
11. This document may not be reproduced or duplicated, in any form, in whole or in part, without prior written consent of Renesas Electronics.
12. Please contact a Renesas Electronics sales office if you have any questions regarding the information contained in this document or Renesas Electronics products, or if you have any other inquiries.

(Note 1) “Renesas Electronics” as used in this document means Renesas Electronics Corporation and also includes its majority-owned subsidiaries.

(Note 2) “Renesas Electronics product(s)” means any product developed or manufactured by or for Renesas Electronics.

M3S-UFLA32R

User's Manual

UART Flash Memory Programming Utility

All information contained in these materials, including products and product specifications, represents information on the product at the time of publication and is subject to change by Renesas Electronics Corp. without notice. Please review the latest information published by Renesas Electronics Corp. through various means, including the Renesas Electronics Corp. website (<http://www.renesas.com>).

Notes regarding these materials

1. This document is provided for reference purposes only so that Renesas customers may select the appropriate Renesas products for their use. Renesas neither makes warranties or representations with respect to the accuracy or completeness of the information contained in this document nor grants any license to any intellectual property rights or any other rights of Renesas or any third party with respect to the information in this document.
2. Renesas shall have no liability for damages or infringement of any intellectual property or other rights arising out of the use of any information in this document, including, but not limited to, product data, diagrams, charts, programs, algorithms, and application circuit examples.
3. You should not use the products or the technology described in this document for the purpose of military applications such as the development of weapons of mass destruction or for the purpose of any other military use. When exporting the products or technology described herein, you should follow the applicable export control laws and regulations, and procedures required by such laws and regulations.
4. All information included in this document such as product data, diagrams, charts, programs, algorithms, and application circuit examples, is current as of the date this document is issued. Such information, however, is subject to change without any prior notice. Before purchasing or using any Renesas products listed in this document, please confirm the latest product information with a Renesas sales office. Also, please pay regular and careful attention to additional and different information to be disclosed by Renesas such as that disclosed through our website. (<http://www.renesas.com>)
5. Renesas has used reasonable care in compiling the information included in this document, but Renesas assumes no liability whatsoever for any damages incurred as a result of errors or omissions in the information included in this document.
6. When using or otherwise relying on the information in this document, you should evaluate the information in light of the total system before deciding about the applicability of such information to the intended application. Renesas makes no representations, warranties or guaranties regarding the suitability of its products for any particular application and specifically disclaims any liability arising out of the application and use of the information in this document or Renesas products.
7. With the exception of products specified by Renesas as suitable for automobile applications, Renesas products are not designed, manufactured or tested for applications or otherwise in systems the failure or malfunction of which may cause a direct threat to human life or create a risk of human injury or which require especially high quality and reliability such as safety systems, or equipment or systems for transportation and traffic, healthcare, combustion control, aerospace and aeronautics, nuclear power, or undersea communication transmission. If you are considering the use of our products for such purposes, please contact a Renesas sales office beforehand. Renesas shall have no liability for damages arising out of the uses set forth above.
8. Notwithstanding the preceding paragraph, you should not use Renesas products for the purposes listed below:
 - (1) artificial life support devices or systems
 - (2) surgical implantations
 - (3) healthcare intervention (e.g., excision, administration of medication, etc.)
 - (4) any other purposes that pose a direct threat to human lifeRenesas shall have no liability for damages arising out of the uses set forth in the above and purchasers who elect to use Renesas products in any of the foregoing applications shall indemnify and hold harmless Renesas Technology Corp., its affiliated companies and their officers, directors, and employees against any and all damages arising out of such applications.
9. You should use the products described herein within the range specified by Renesas, especially with respect to the maximum rating, operating supply voltage range, movement power voltage range, heat radiation characteristics, installation and other product characteristics. Renesas shall have no liability for malfunctions or damages arising out of the use of Renesas products beyond such specified ranges.
10. Although Renesas endeavors to improve the quality and reliability of its products, IC products have specific characteristics such as the occurrence of failure at a certain rate and malfunctions under certain use conditions. Please be sure to implement safety measures to guard against the possibility of physical injury, and injury or damage caused by fire in the event of the failure of a Renesas product, such as safety design for hardware and software including but not limited to redundancy, fire control and malfunction prevention, appropriate treatment for aging degradation or any other applicable measures. Among others, since the evaluation of microcomputer software alone is very difficult, please evaluate the safety of the final products or system manufactured by you.
11. In case Renesas products listed in this document are detached from the products to which the Renesas products are attached or affixed, the risk of accident such as swallowing by infants and small children is very high. You should implement safety measures so that Renesas products may not be easily detached from your products. Renesas shall have no liability for damages arising out of such detachment.
12. This document may not be reproduced or duplicated, in any form, in whole or in part, without prior written approval from Renesas.
13. Please contact a Renesas sales office if you have any questions regarding the information contained in this document, Renesas semiconductor products, or if you have any other inquiries.

Precautions on Using The Product Described Herein

1. The product described herein should be used in combination with the parts included with the starter kit. If the product is operated in combination with any other item, its operation cannot be guaranteed. Nor will requests for help or suggestion be answered.
2. The product described herein was prepared for program development or evaluation purposes. The product cannot be used for the mass production.
3. Renesas Technology Corporation and Renesas Solutions Corporation will not assume any responsibility for the results of development no matter what systems may have been developed by customers by using the product described herein.
4. Guarantee for the product described herein shall conform to stipulations under which guarantee is provided for the starter kit.
5. The product described herein was prepared assuming it will be used in a laboratory or similar environment for program development or evaluation purposes. It is not covered in the electrical product safety laws, nor is it protected against electromagnetic hazards for use in Japan or elsewhere.

For Inquiries About Product Contents or This Manual

Please contact:
Renesas Technology Corporation
at csc@renesas.com

* Microsoft, MS-DOS, Windows, and Windows NT are registered trademarks of Microsoft Corporation in the U.S. and other countries.

* Adobe and Acrobat are registered trademarks of Adobe Systems Incorporated.

* All other brand names and product names are trademarks or registered trademarks of each proprietary company.

Contents

1. Overview	1
2. System Configuration	1
2.1 Outline of the M3S-UFLA32R.....	1
2.2 Communication Cable (M3A-2145G50).....	2
2.3 Target MCU/Target Board.....	4
2.4 Host PC	4
3. Installation of the M3S-UFLA32R.....	5
3.1 Installation of the M3S-UFLA32R.....	5
4. Operation Method of the M3S-UFLA32R	6
4.1 Startup	6
4.2 Exit.....	6
4.3 Operation Outline of the M3S-UFLA32R.....	6
5. Function Description of the M3S-UFLA32R	8
5.1 Function list	8
5.2 Program Data (Motorola S-format file) Selection	9
5.3 Exit the Application	10
5.4 Lock Bit Information.....	11
5.5 Program.....	13
5.6 Erase	14
5.7 Block Erase	15
5.8 Lock Bit/Set	17
5.9 Lock Bit/Enable.....	19
5.10 Lock Bit/Disable.....	20
5.11 Blank Check.....	21
5.12 Verify Check	22
5.13 E.B.P.V. (Erase, Blank Check, Program, Verify Check)	23
5.14 E.P. (Erase, Program).....	23
5.15 B.P.V. (Blank Check, Program, Verify Check)	24
5.16 Setting	25
5.17 ID Code Setting	27
5.18 Version Information	29
6. Error Message List	30

1. Overview

This user's manual is intended to provide explanations about system configuration and operation method of the UART Flash Memory Programming Utility M3S-UFLA32R Ver.1.40 (hereinafter referred to as M3S-UFLA32R) for the M32R/ECU Series (Refer to the Table 2.3.1 for corresponding MCU).

2. System Configuration

Figure 2.1.1 shows connection configuration of the system using the M3S-UFLA32R

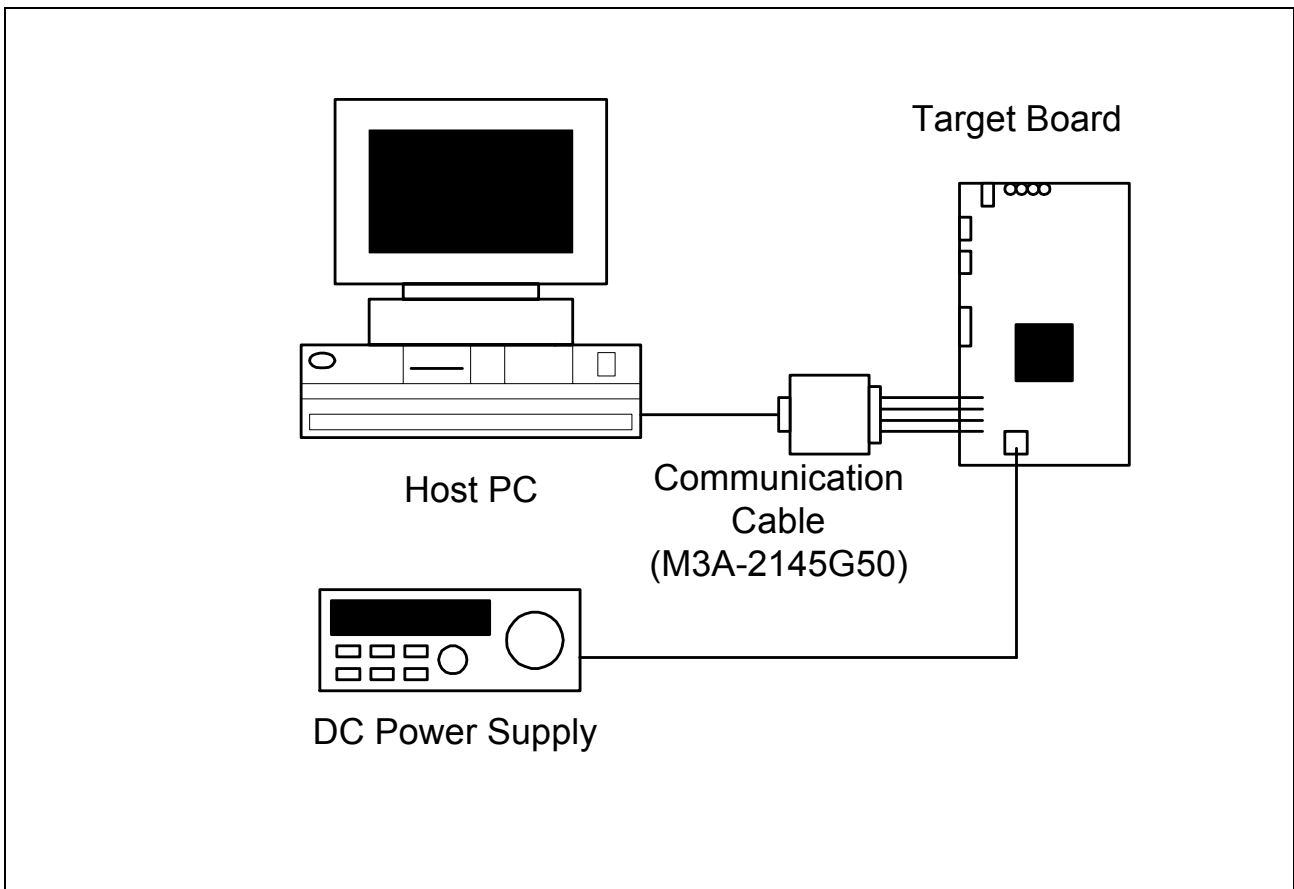

Figure 2.1.1 Connection Configuration

2.1 Outline of the M3S-UFLA32R

The M3S-UFLA32R is a Windows application program that performs UART communication with SIO1 of a MCU serial interface by the boot program built into a MCU (flash programming firmware) and executes write/erase operation to the MCU flash memory.

2.2 Communication Cable (M3A-2145G50)

Communication cable consists of two different cables below.

- Interface Cable (M3A-2145G02)

It is a conversion cable to connect to the test pins on the target when the connection cable for the MF-TEN-NINE can not be mounted on the target board. Figure 2.2.1 shows connecting diagram.

- MF-TEN-NINE Cable (M3A-0652CBL)

It is a cable to connect host PC to target board. Figure 2.2.2 shows connecting diagram.

Communication cable receives power supply from the target board. The power supply voltage can be used at 3.3V or 5.0V.

Table 2.2.1 shows usage specification of the communication cable.

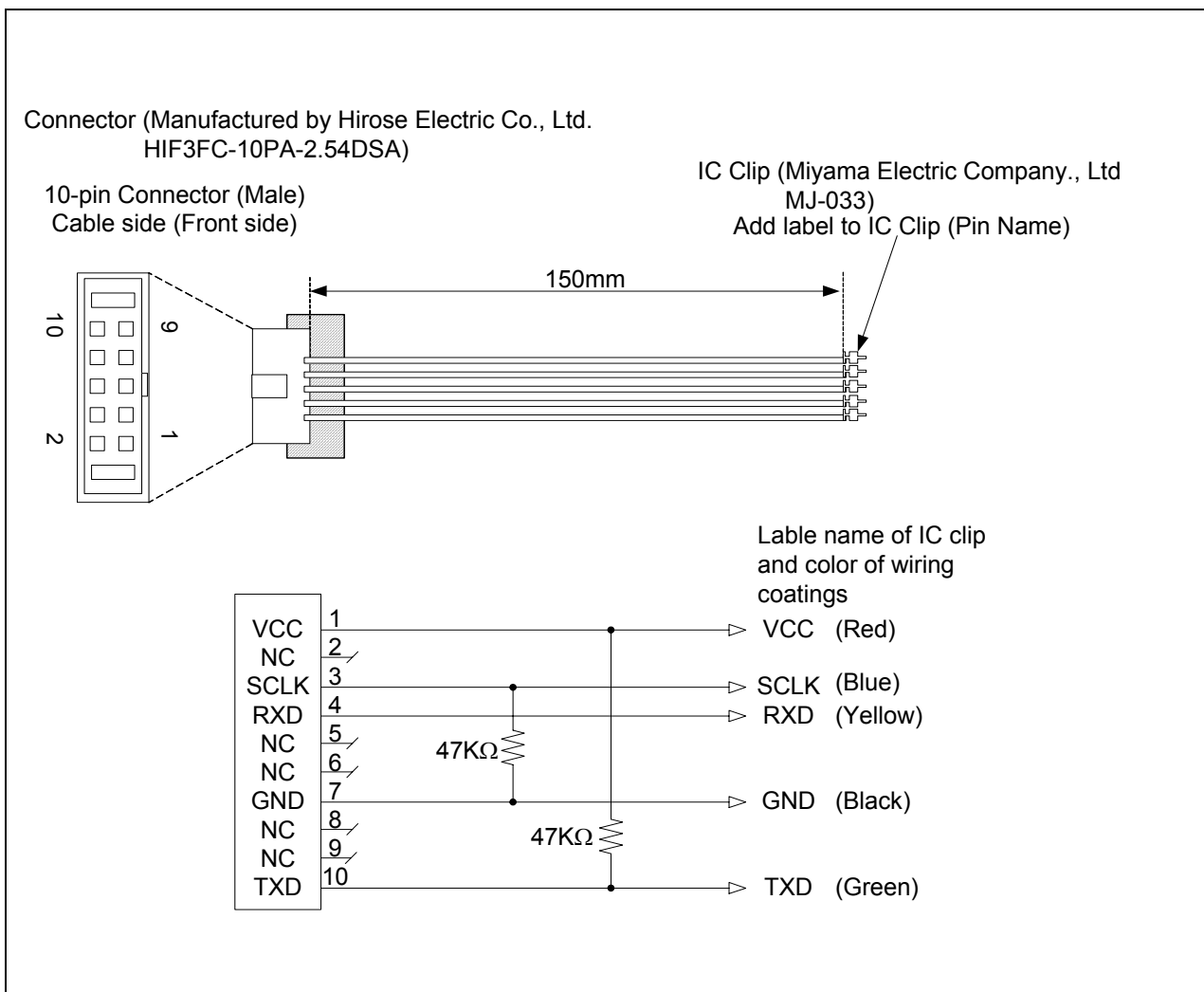

Figure 2.2.1 Interface Cable Connecting Diagram

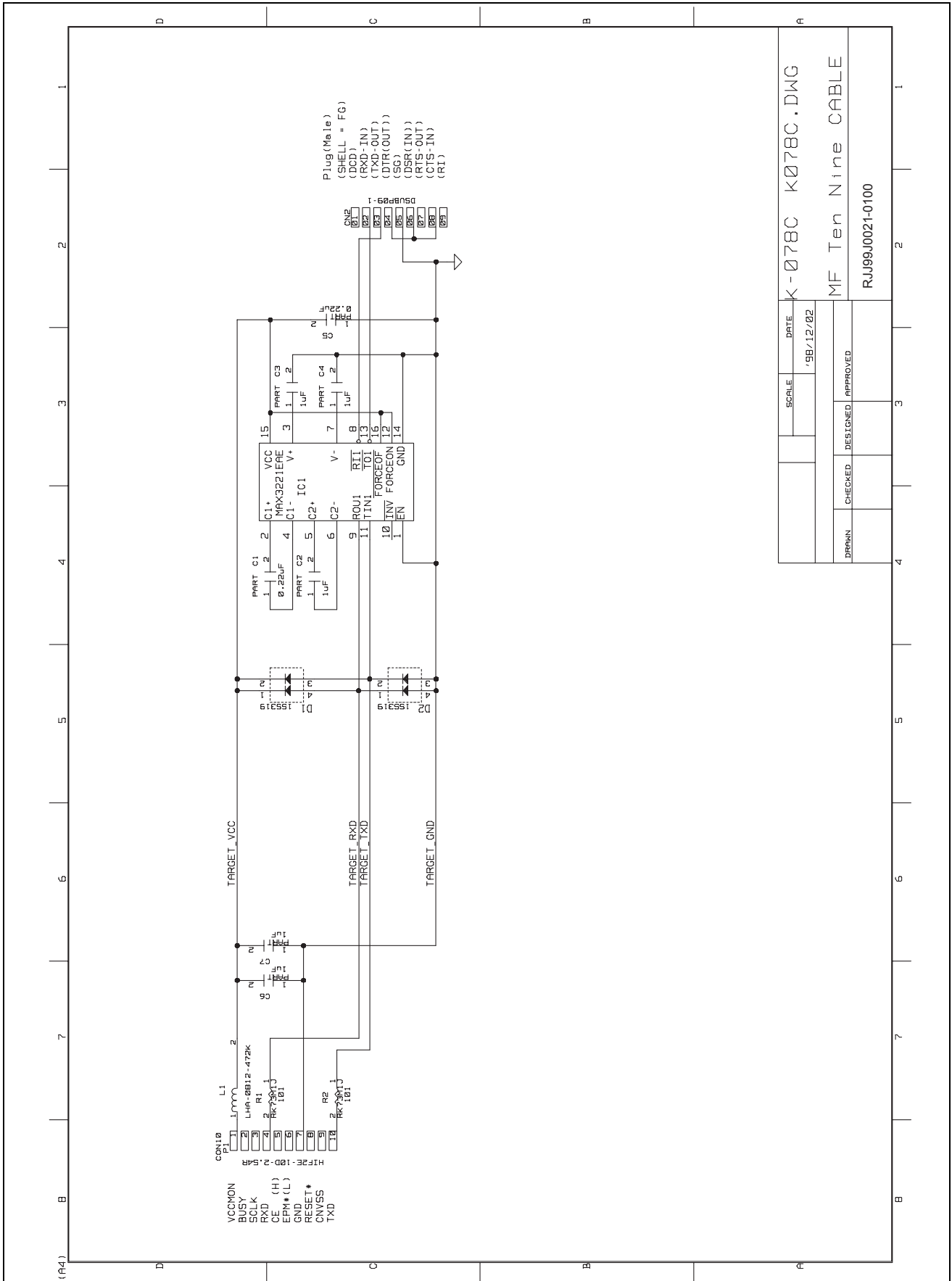

Figure 2.2.2 MF-TEN-NINE Cable Connecting Diagram

Table 2.2.1 Usage Specification

Parameter	Rated Value		Unit	Condition
	MIN	MAX		
DC Power Supply	3.0	3.6	V	Target Supply Voltage
	4.5	5.5	V	Target Supply Voltage
RS-232C Communication Rate	9600	115200	bps	Communication Speed with PC
Consumption Current	-	60	mA	MAX3221EAE Specification
Operating Ambient Temperature	5	35	°C	No Condensation, No Corrosive Gas Environment
Storage Ambient Temperature	0	60	°C	No Condensation, No Corrosive Gas Environment

2.3 Target MCU/Target Board

Target MCU and Target Board should be prepared by the user.

Table 2.3.1 lists the M3S-UFLA32R compatible MCUs and Target Boards.

Table 2.3.1 Target MCU and Target Board

Target MCU	Target Board Type Name	Starter Kit Type Name
32170/32174 Group	M3A-2114G02	M3A-2114G52, M3A-2114G52A
32171 Group	M3A-2114G12	M3A-2114G62, M3A-2114G62A
32172/32173 Group	M3A-2114G22	M3A-2114G72, M3A-2114G72A
32176 Group	M3A-2152G02	M3A-2152G52, M3A-2152G52A
32180 Group	M3A-2142G02	M3A-2142G52, M3A-2142G52A
32182 Group	M3A-2142G12	M3A-2142G62, M3A-2142G62A
32185/32186 Group	M3A-2154G02A	M3A-2154G52B
32192/32195/32196 Group	M3A-2154G02, M3A-2154G02A	M3A-2154G52A, M3A-2154G52B

2.4 Host PC

Table 2.4.1 shows the system requirements of a host PC. Host PC should be prepared by the user.

Table 2.4.1 System Requirements of a Host PC

Host PC	IBM PC/AT and its Compatible Machine
OS	Windows 2000 Windows XP
Communication Port	COM1

3. Installation of the M3S-UFLA32R

3.1 Installation of the M3S-UFLA32R

To install the M3S-UFLA32R, perform the following steps.

- 1) Execute Setup.exe in "¥Eng¥Tool¥Ufla32r¥W95E" folder contained in the provided CD. (Note1)
- 2) Continue installation by following the instruction of the installation window.
- 3) Installation is completed when Setup Complete dialog appears.

Note 1: To use the file which is downloaded from our homepage, uncompress the file before execute Setup.exe.

Note: Administrator authority is required to install software under Windows2000 and WindowsXP.

4. Operation Method of the M3S-UFLA32R

4.1 Startup

Double-click the icon after the M3S-UFLA32R setup is completed.

4.2 Exit

Choose [Exit(X)] from [File(F)] menu.

4.3 Operation Outline of the M3S-UFLA32R

To write to the flash memory, perform the following steps.

1) Connecting Host PC to Target Board

- Connect D-Sub 9 pin connector of the MF-TEN-NINE cable to COM1 of the host PC.
- Connect MF-TEN-NINE cable to the interface cable.
- Connect IC clip of the interface cable to the target board by referring to Table 4.3.1.

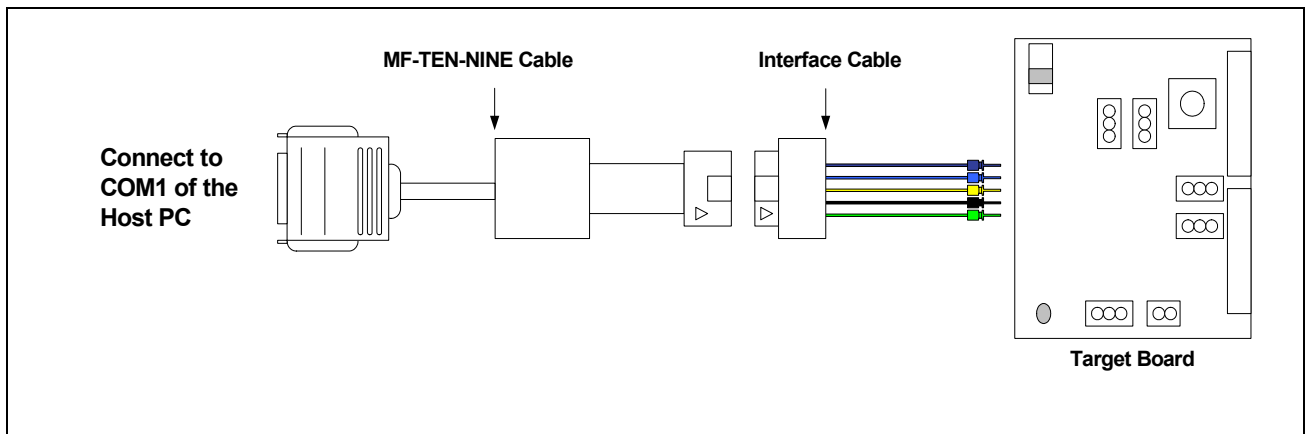

Figure 4.3.1 Connection Diagram

Table 4.3.1 Connecting Interface Cable to the Target Board

Interface Cable		Destination of the Target Board Connection
IC Clip Color	IC Clip Pin Name	
Red	VCC	VCCE power supply
Blue	SCLK	P87 pin
Yellow	RXD	P86 pin (RXD1)
Black	GND	GND pin
Green	TXD	P85 pin (TXD1)

2) Setting for FP Pin, MOD0 Pin, and MOD1 Pin

Set FP pin of the target board to "H," MOD0 pin to "H," and MOD1 pin to "L," respectively.
For setting procedure, refer to respective board manuals.

3) Power to the Target Board

Start power supply to the target board.

4) Reset the Target MCU

Reset the target MCU by pressing the reset switch on the target board.

5) Starting the M3S-UFLA32R

Start the M3S-UFLA32R.

6) Execution of Writing to the Flash Memory by the M3S-UFLA32R

Operate the M3S-UFLA32R and perform writing to the flash memory.

For detail about operation method, refer to "5. Function Description of the M3S-UFLA32R."

Note: During erasing or writing, it is prohibited to reset the target board and to turn off the power.

7) Exit the M3S-UFLA32R

Exit the M3S-UFLA32R.

8) Power off the Target Board

Cut the power supply to the target board.

5. Function Description of the M3S-UFLA32R

5.1 Function List

Table 5.1 lists functions of the M3S-UFLA32R. Choose each function from menu or click a button for execution.

Table 5.1 Function List

	Menu	Button	Function	Reference
File	Load	Refer	Read the program data of specified Motorola S format file into the internal buffer	5.2
	Exit	-	Exit the M3S-UFLA32R	5.3
Display	Lock Bit Information	-	Display lock bit information	5.4
Device	Program	Program	Write program data from internal buffer to the flash memory	5.5
	Erase	Erase	Erase all blocks from the flash memory	5.6
	Block Erase	-	Erase the specified blocks from the flash memory	5.7
	Lock Bit / Set	-	Write lock bit to the specified blocks in the flash memory	5.8
	Lock Bit / Enable	-	Enable memory protect by the lock bit	5.9
	Lock Bit / Disable	-	Disable memory protect by the lock bit	5.10
	Blank Check	Blank Check	Check if all the flash memory blocks are erased	5.11
	Verify Check	Verify Check	Check if the program data of internal buffer and the program data written to the flash memory are corresponding	5.12
	Batch processing / E.B.P.V.	E.B.P.V.	Consecutively execute Erase, Blank Check, Program, and Verify Check	5.13
	Batch processing / E.P.	E.P.	Consecutively execute Erase and Program	5.14
Batch processing / B.P.V.	B.P.V.	Consecutively execute Blank Check, Program, and Verify Check	5.15	
Others	Setting	-	Perform MCU selection, Verify method selection, and ID code write control	5.16
	ID Code Setting	-	Set the ID code to be used at ID verification	5.17
Help	Version information	-	Display the versions of the M3S-UFLA32R and F/W	5.18

5.2 Program Data (Motorola S-format file) Selection

- (1) Choose [Load(L)] from [File(E)] menu or click [Refer] button.

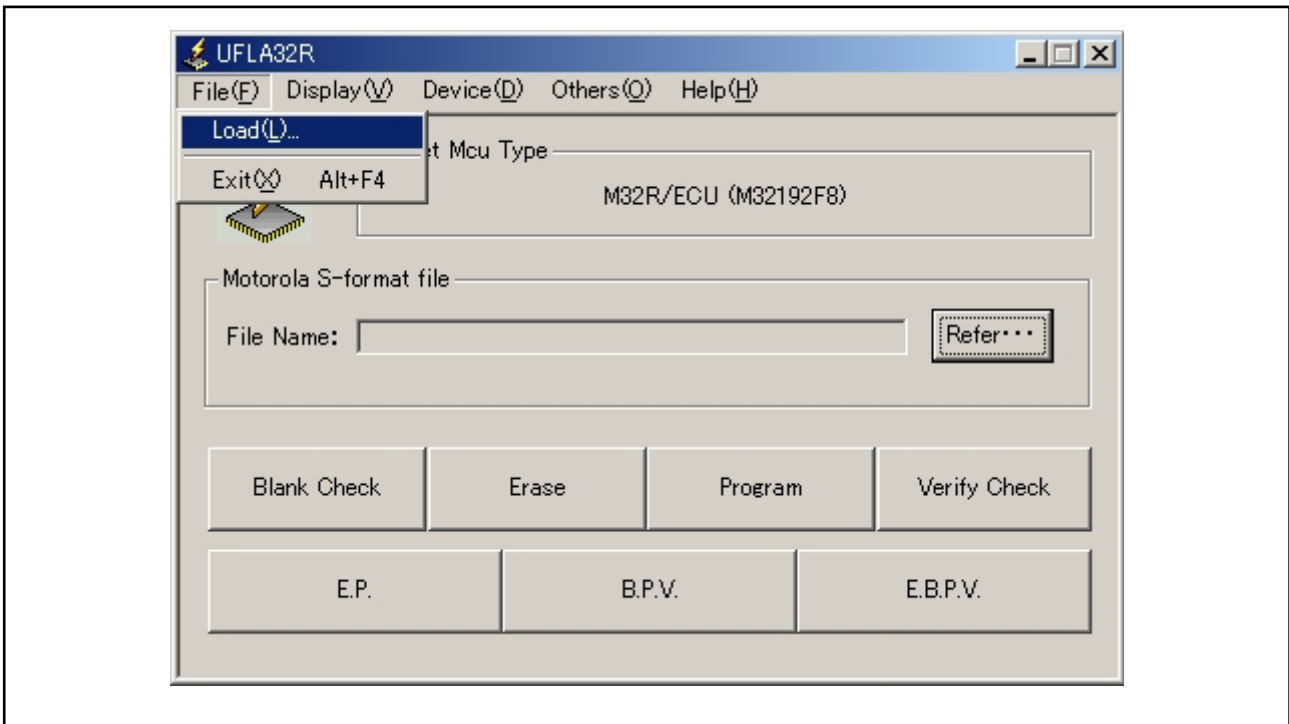

Figure 5.2.1 Program Data Selection

- (2) When “Open File” dialog opens, choose a program data file (Motorola S-format file) and then click [Open(O)] button.

Note: As a file format, the M3S-UFLA32R supports Motorola S-format only.

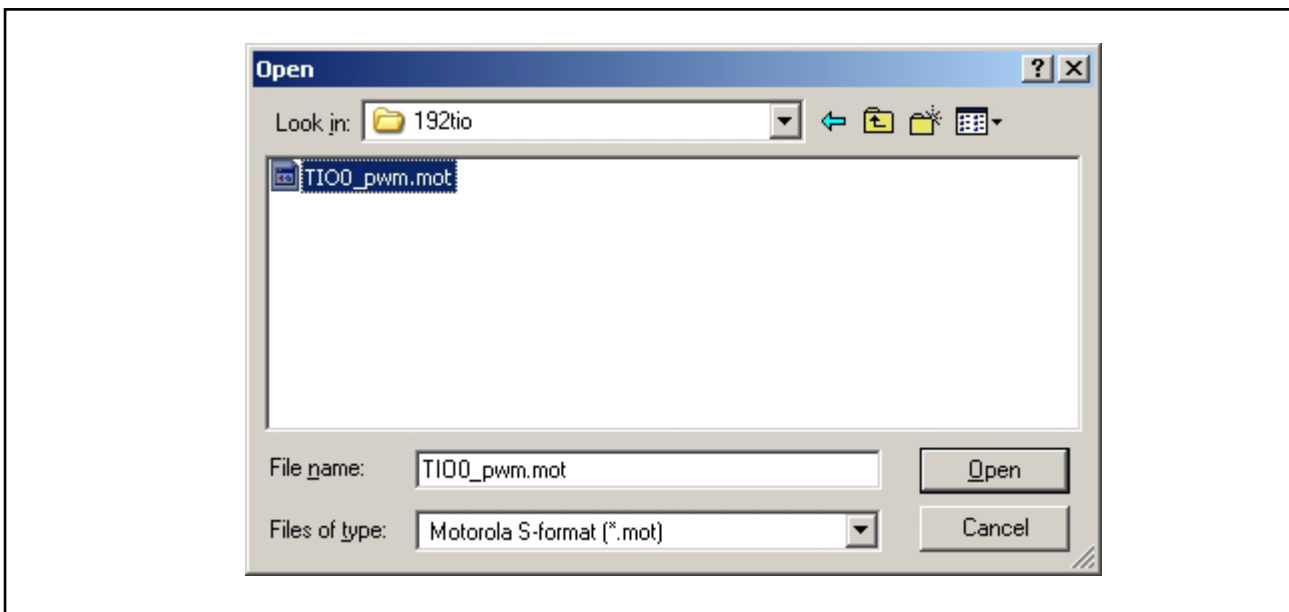

Figure 5.2.2 Open File Dialog

- (3) Choose a file to display the dialog that shows execution process, and then read program data file into the internal buffer. After completing read, the dialog is closed and file name is displayed in "File Name:" box.

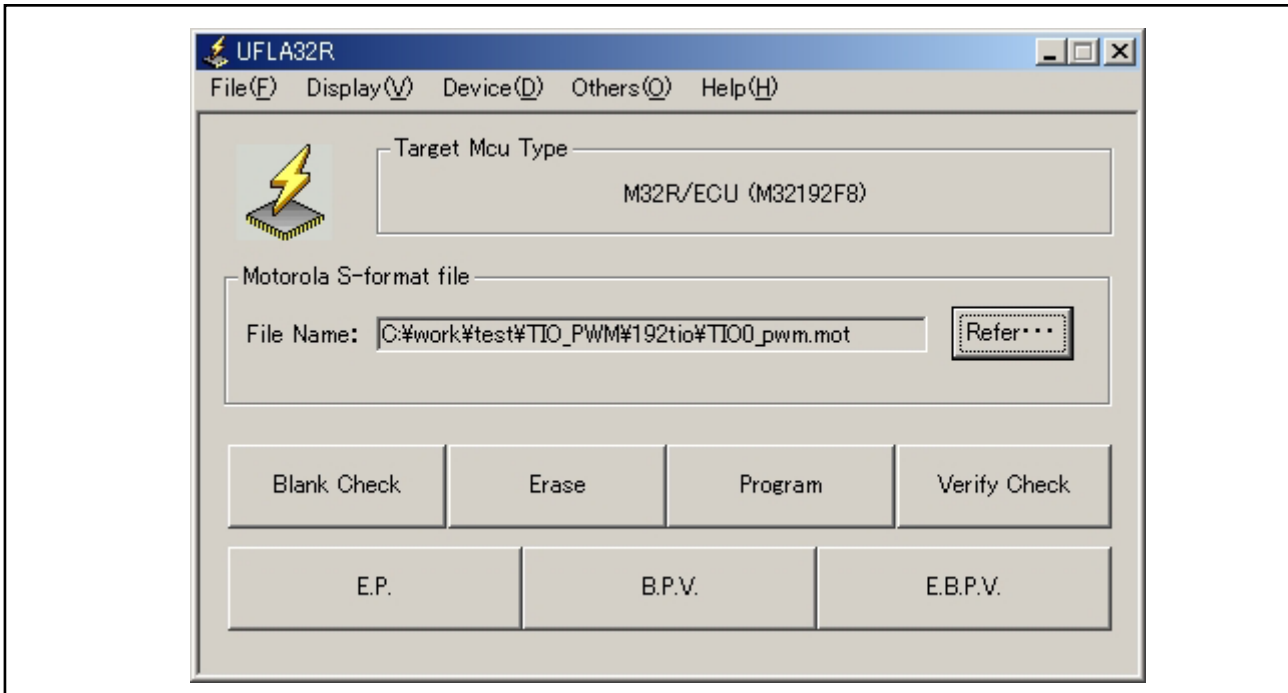

Figure 5.2.3 Result of Choosing Program Data

5.3 Exit the Application

- (1) Choose [Exit(X)] from [File(E)] menu to exit the program.
Also, it is able to exit the program by pushing [Alt + F4] keys or clicking the close button.

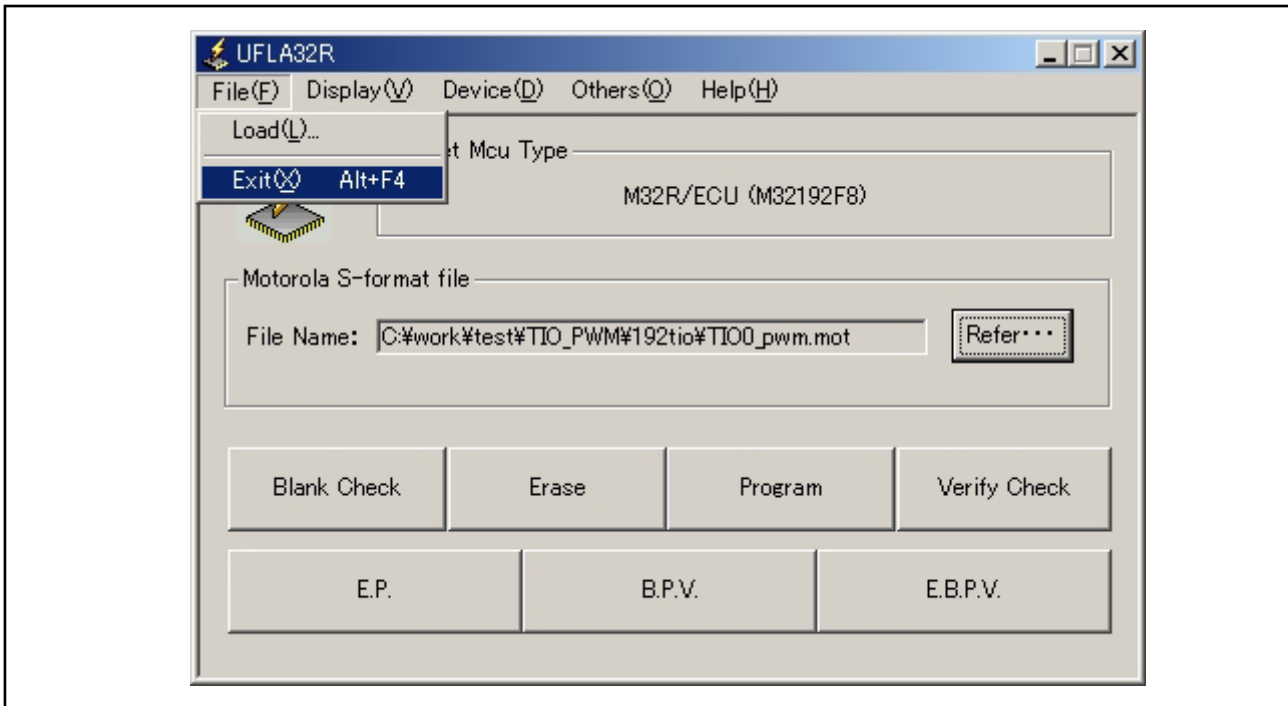

Figure 5.3.1 Exit the Application

5.4 Lock Bit Information

- (1) Choose [Lock Bit Information (L)] from [Display(V)] menu to display the dialog that shows execution process, and then read lock bit. After completing read of lock bit, the dialog is closed and "Lock Bit Status Display" dialog is displayed.

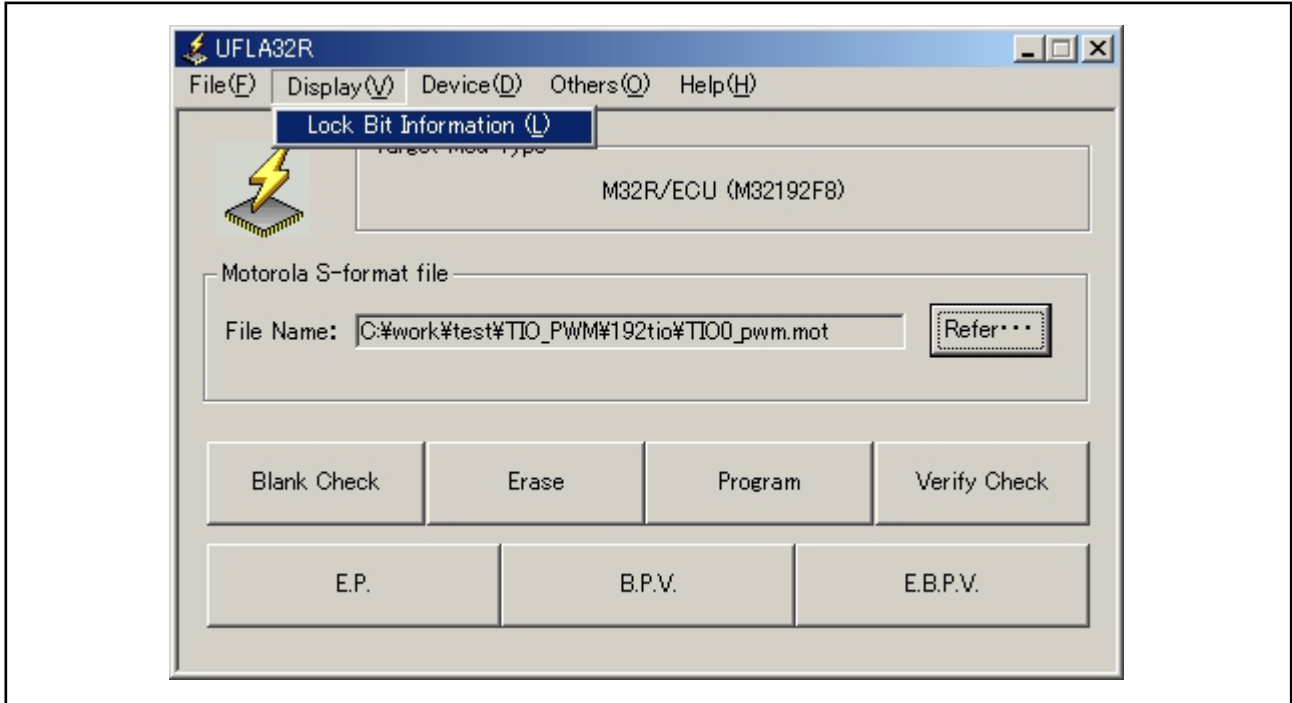

Figure 5.4.1 Lock Bit Information

- (2) Click [Cancel] while reading out lock bit status to close the dialog that shows execution process.

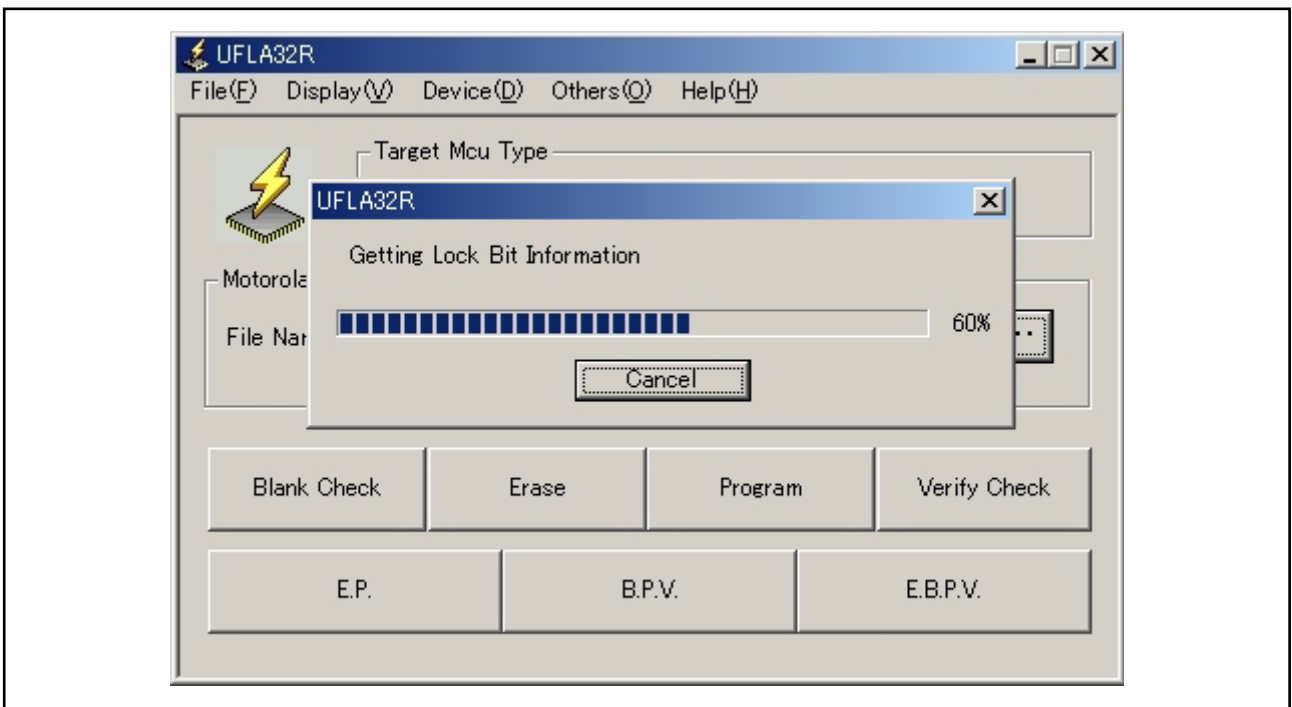

Figure 5.4.2 Reading out Lock Bit Status

- (3) In [Lock Bit Status Display] dialog, the lock bit statuses of all blocks of currently selected MCU are displayed. Click [OK] to close "Lock Bit Status Display" dialog.

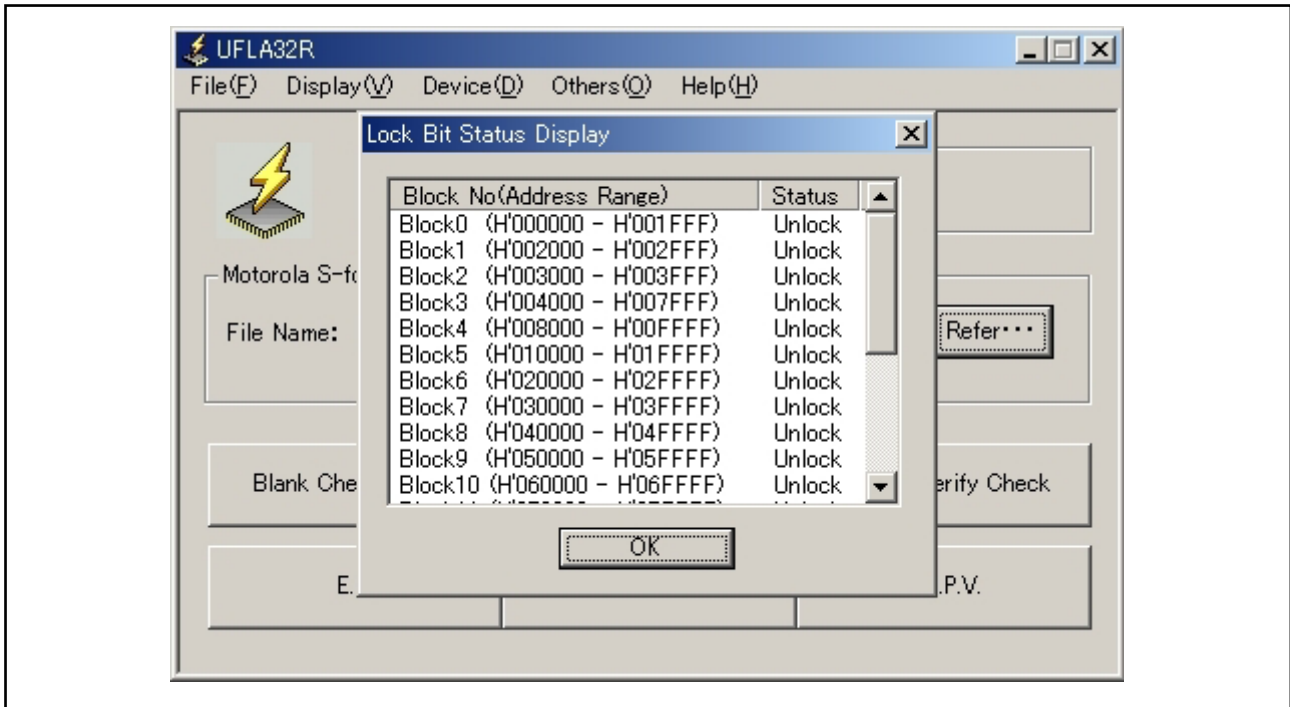

Figure 5.4.3 Lock Bit Status Display Dialog

5.5 Program

- (1) Choose [Program(P)] from [Device(D)] menu or click [Program] button to display the dialog that shows execution process, and then write program data stored in the internal buffer to the flash memory. After completing write of program data, the dialog is closed and "Program ...finish" dialog is displayed.

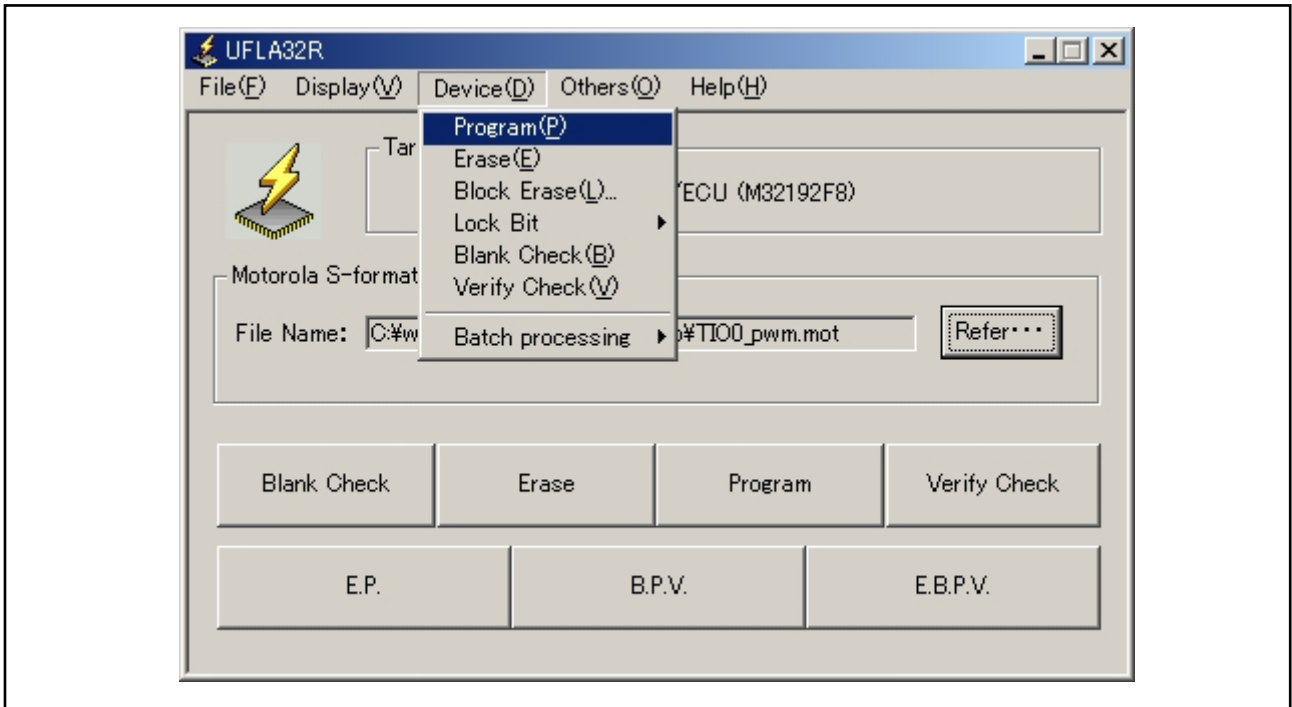

Figure 5.5.1 Program

- (2) Click [OK] in the "Program...finish" dialog to close the dialog

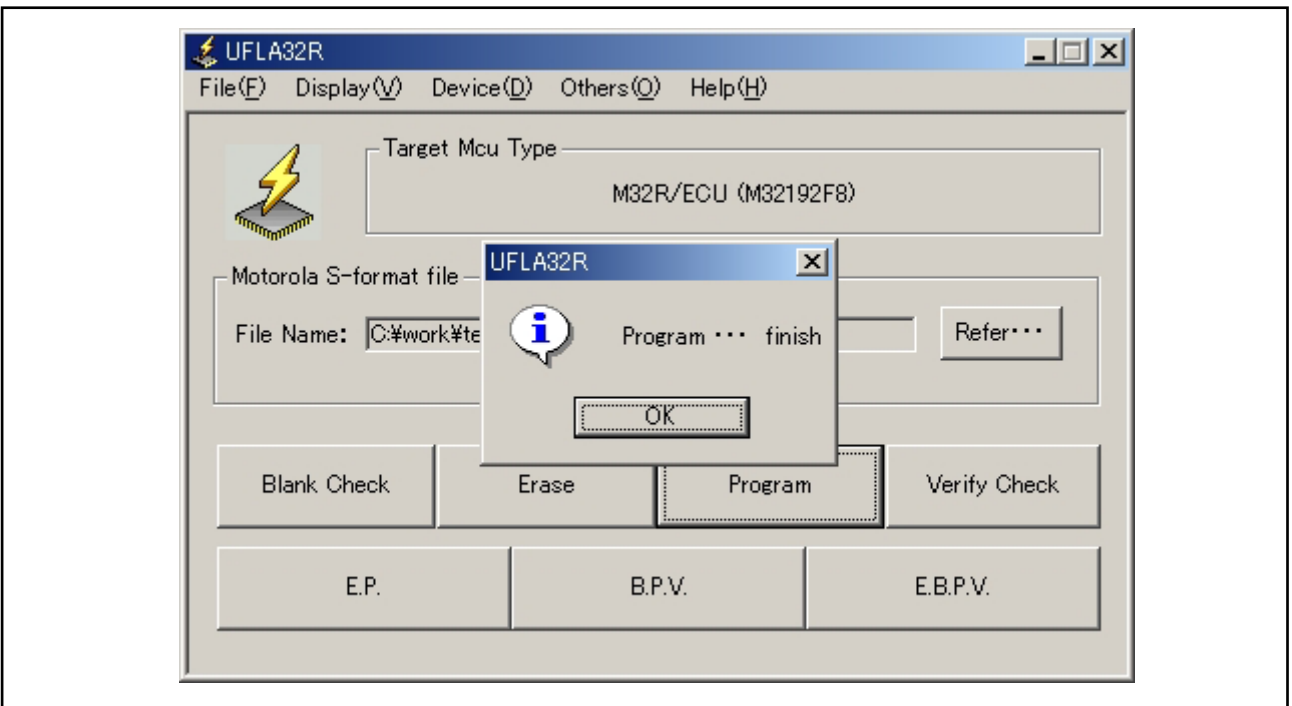

Figure 5.5.2 Program Finish Dialog

5.6 Erase

- (1) Choose [Erase(E)] from [Device(D)] menu or click [Erase] button to display the dialog that shows execution process, and then erase the flash memory. After completing the flash memory erasing, the dialog is closed and "Erase ...finish" dialog is displayed.

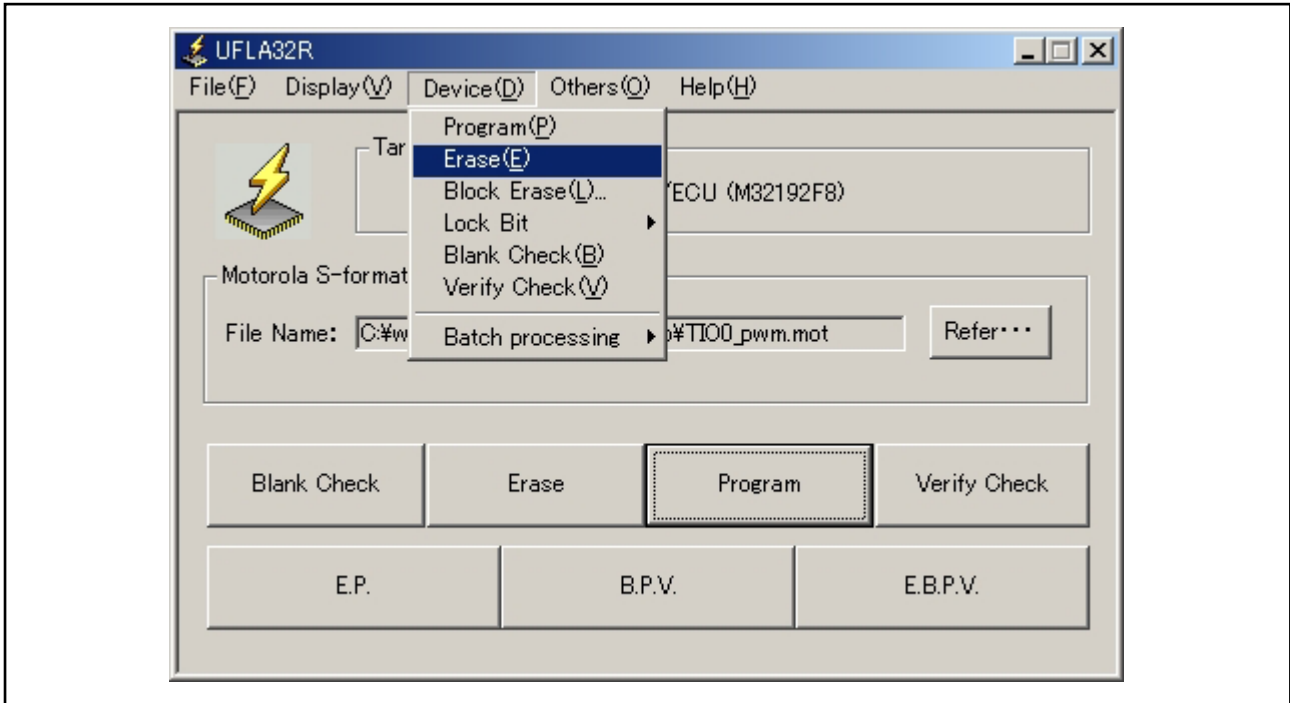

Figure 5.6.1 Erase

- (2) Click [OK] in the "Erase...finish" dialog to close the dialog.

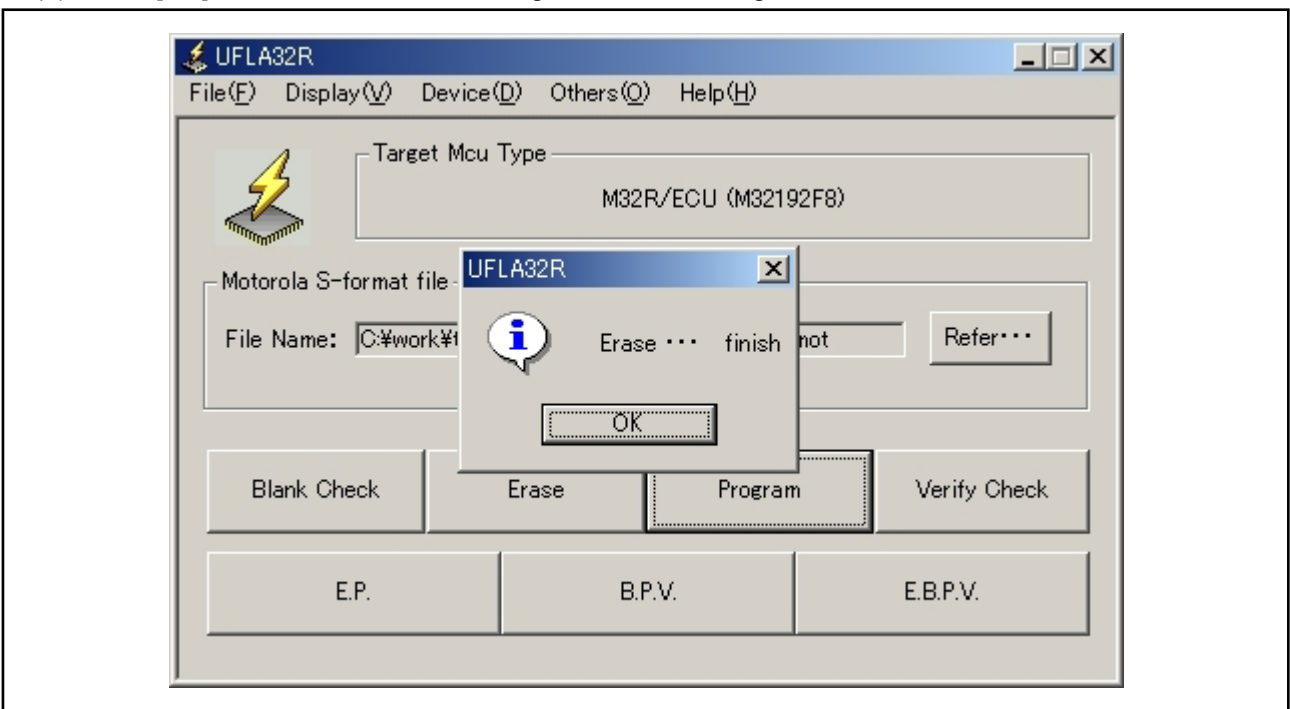

Figure 5.6.2 Erase Finish Dialog

5.7 Block Erase

- (1) Choose [Block Erase(L)] from [Device(D)] menu to display "Block Erase" dialog.

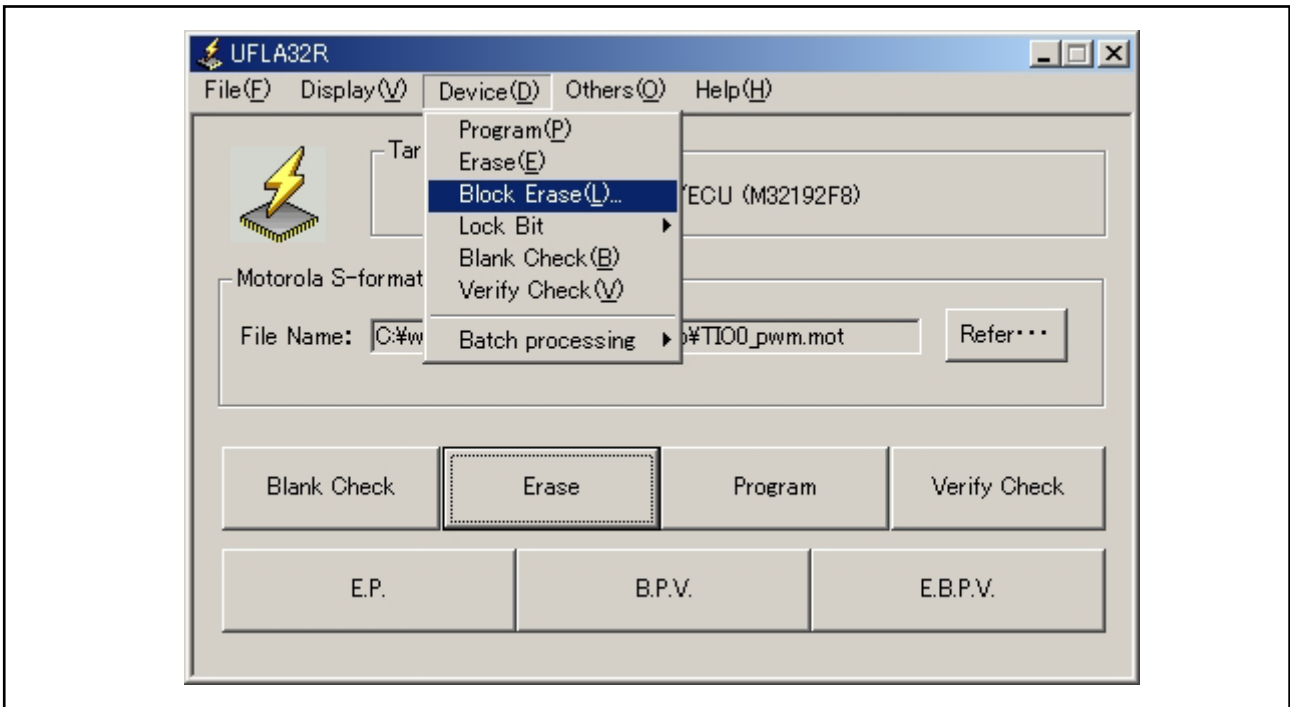

Figure 5.7.1 Block Erase

- (2) In "Block Erase" dialog, all blocks of currently selected MCU are displayed. Click [Select All] to select all blocks.
Click [Clear] button to clear all selected blocks.
Select the blocks you wish to erase and click [OK] to close "Block Erase" dialog. Subsequently, the dialog that shows execution process appears and the selected blocks are erased. After completing erasing, the dialog is closed and "Block Erase ...finish" dialog is displayed. Click [Cancel] to close "Block Erase" dialog.

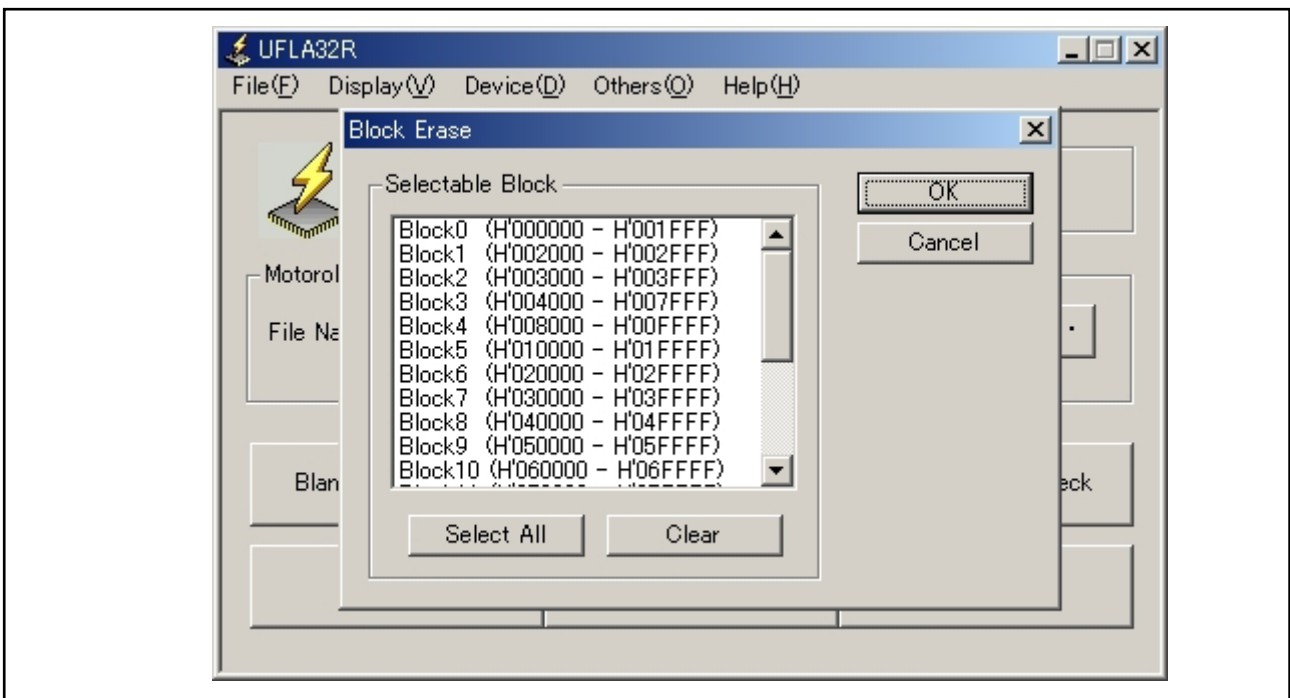

Figure 5.7.2 Block Erase Dialog

(3) Click [OK] in the "Block Erase...finish" dialog to close the dialog.

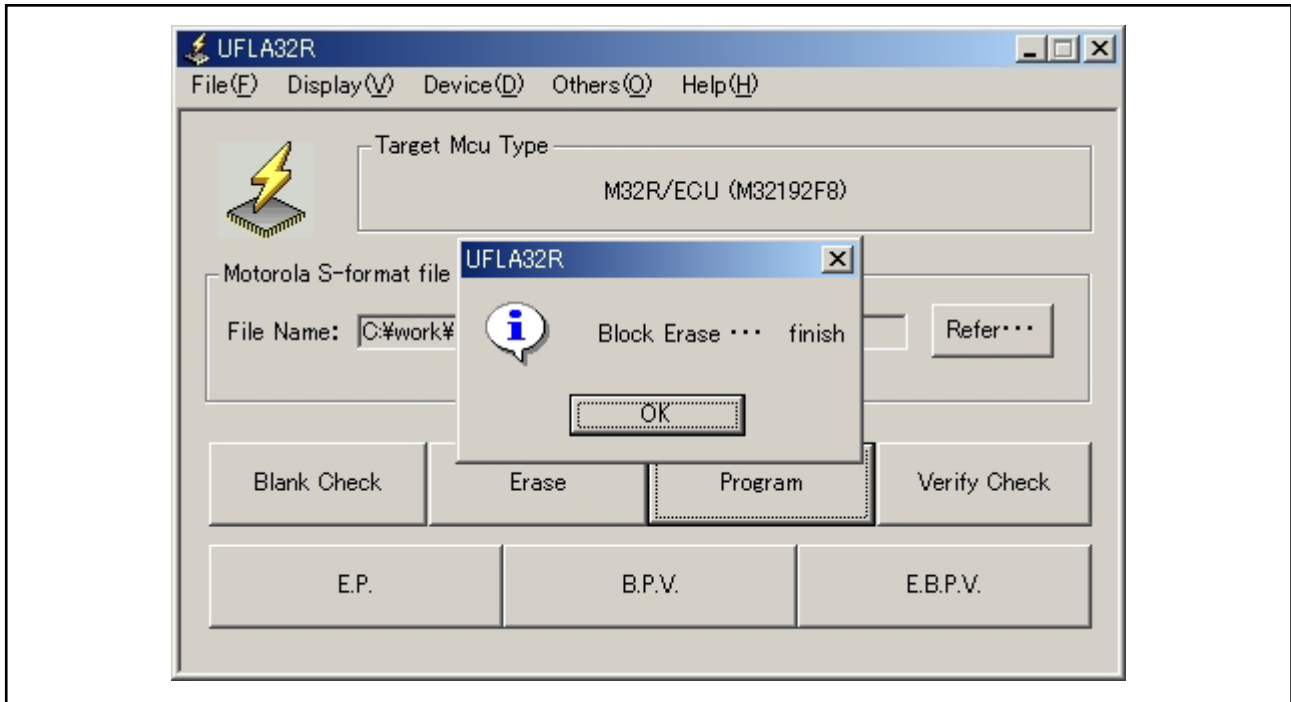

Figure 5.7.3 Block Erase Finish Dialog

5.8 Lock Bit/Set

- (1) Choose [Lock Bit]-[Set(S)] from [Device(D)] menu to display the dialog that shows execution process, and then read out lock bit. After completing read of lock bit, the dialog is closed and "Lock Bit Set" dialog is displayed.

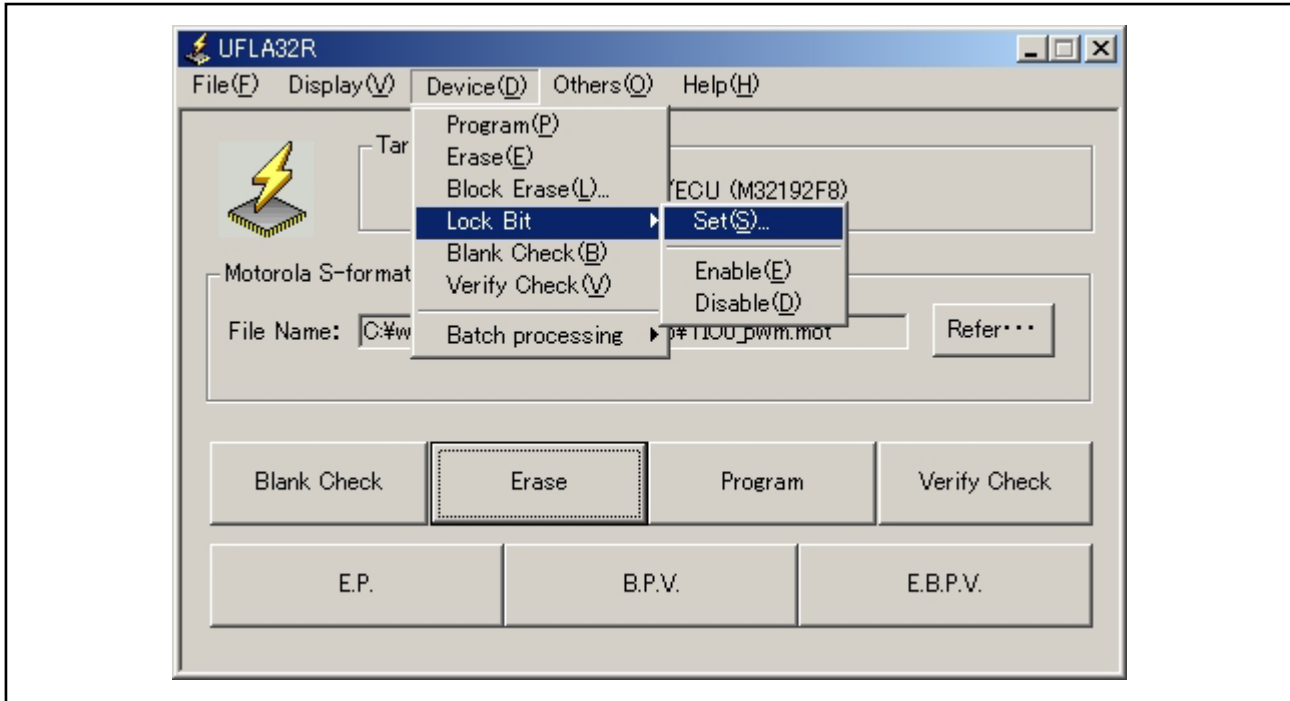

Figure 5.8.1 Lock Bit Set

- Note: To clear lock bit, perform the following steps.
1. Execute [Lock Bit]-[Disable(D)] in [Device(D)] menu.
 2. Execute [Erase(E)] or [Block Erase(L)] in [Device(D)] menu.
- By following the procedures above, lock bit in the corresponding block can be cleared.
 This is the only way to clear lock bit.

- (2) In "Lock Bit Set" dialog, the blocks without setting of lock bit are displayed.
 Click [Select All] to select all blocks.
 Click [Clear] to clear all selected blocks.
 Select the blocks you wish to set lock bit to, and then click [OK] to close "Lock Bit Set" dialog.
 Subsequently, the dialog that shows execution process appears and the lock bit is set. After completing setting, the dialog is closed and "Lock Bit Set ...finish" dialog is displayed.
 Click [Cancel] to close "Lock Bit Set" dialog.

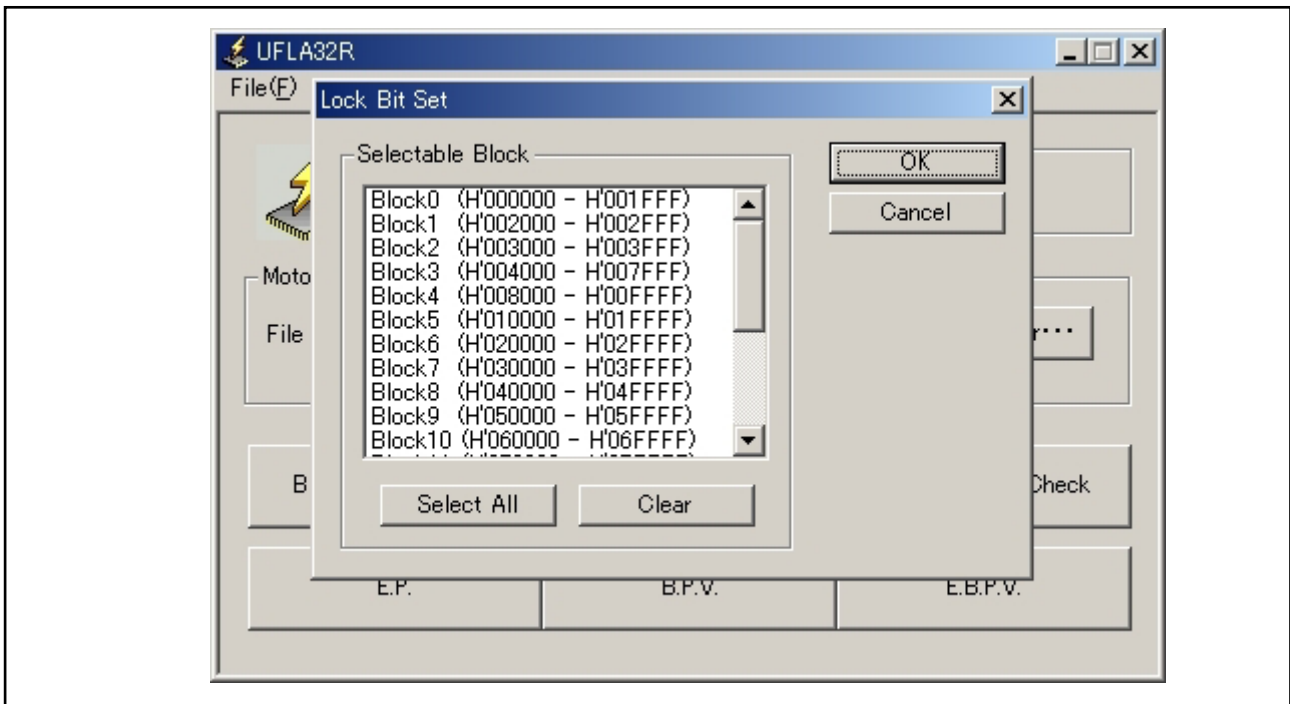

Figure 5.8.2 Lock Bit Set Dialog

- (3) Click [OK] in the "Lock Bit Set...finish" dialog to close the dialog.

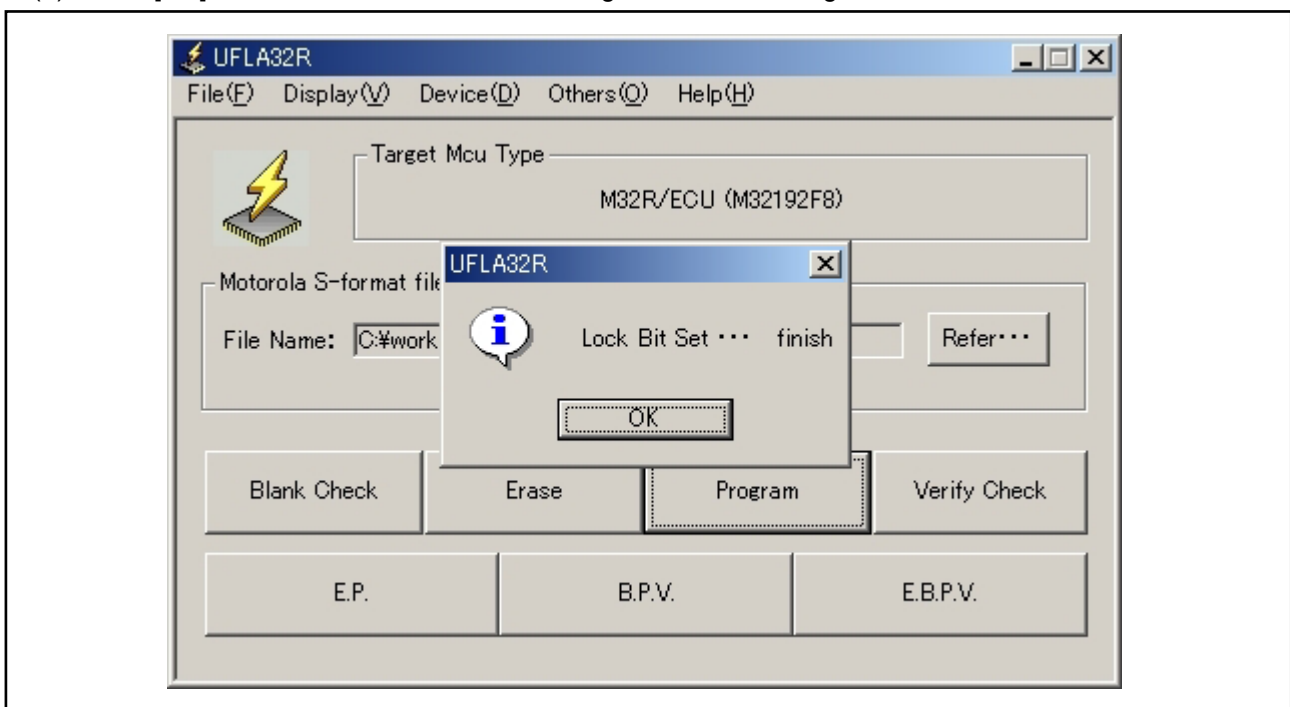

Figure 5.8.3 Lock Bit Set Finish Dialog

5.9 Lock Bit/Enable

- (1) Choose [Lock Bit]-[Enable(E)] from [Device(D)] menu to display the dialog that shows execution process, and then enable lock bit. After completing enabling lock bit, the dialog is closed and "Lock Bit Enable...finish" dialog is displayed.

Note: It can not perform erase or write operation against the block with the lock bit that is enabled and set. Clear lock bit to perform erase or write operation. After powering, lock bit becomes enabled.

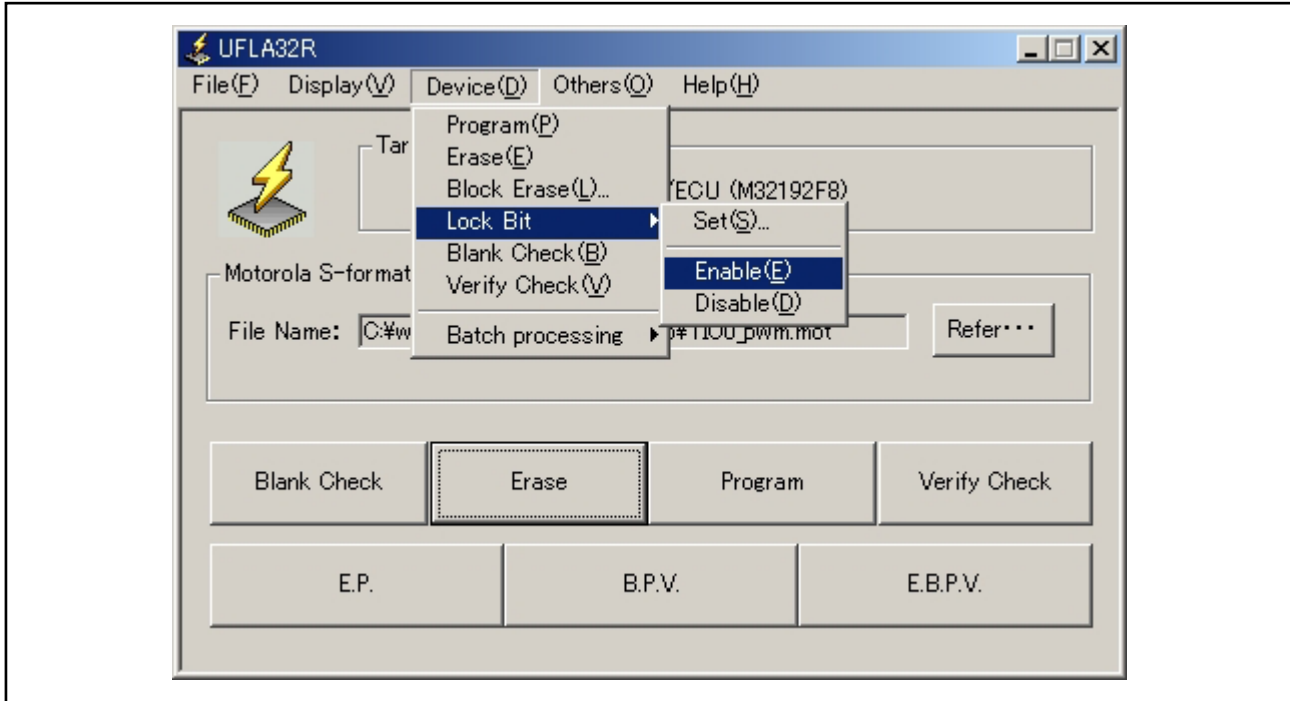

Figure 5.9.1 Lock Bit Enable

- (2) Click [OK] in the "Lock Bit Enable...finish" dialog to close the dialog.

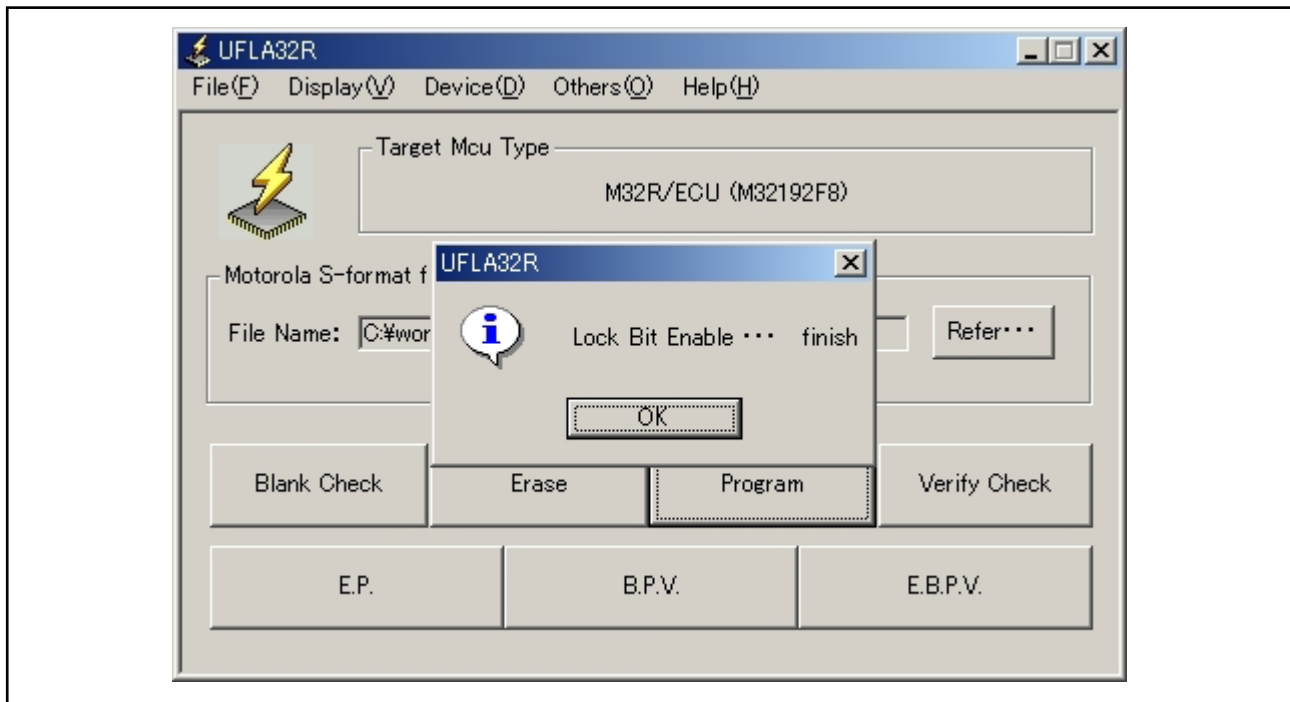

Figure 5.9.2 Lock Bit Enable Finish Dialog

5.10 Lock Bit/Disable

- (1) Choose [Lock Bit]-[Disable(D)] from [Device(D)] menu to display the dialog that shows execution process, and then disable lock bit. After completing disabling lock bit, the dialog is closed and "Lock Bit Disable...finish" dialog is displayed.

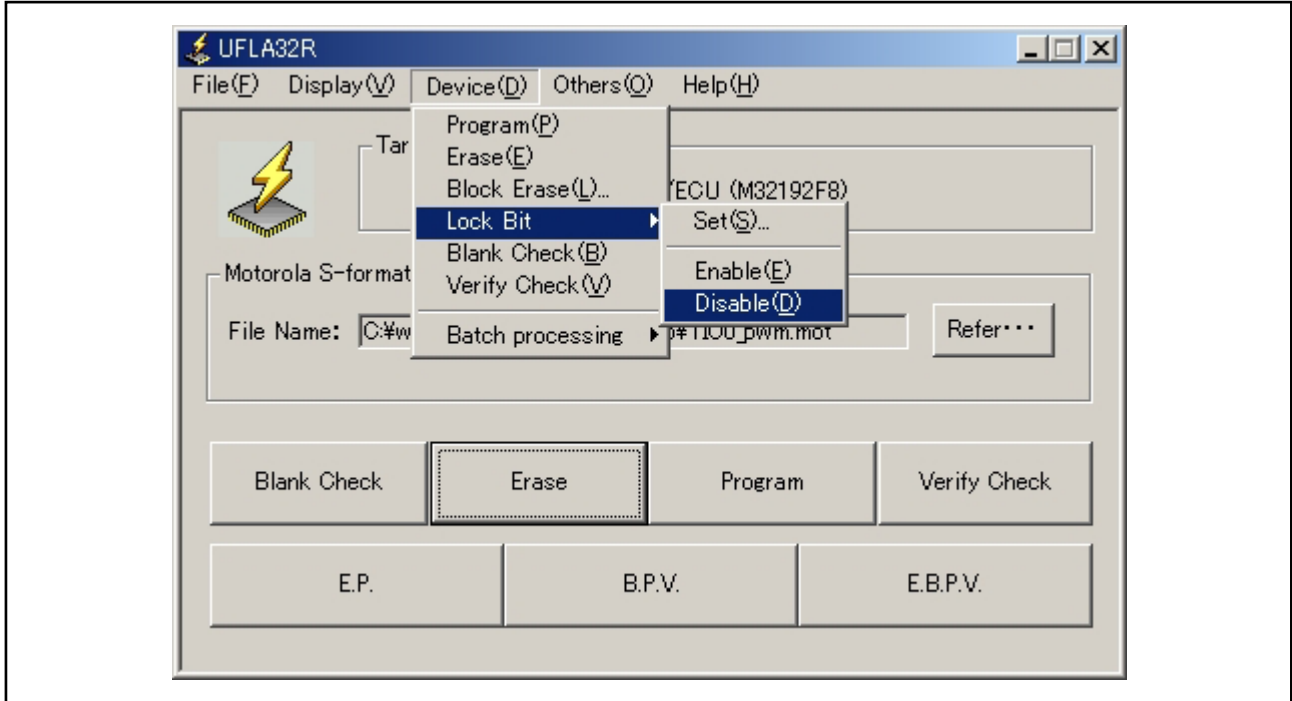

Figure 5.10.1 Lock Bit Disable

- (2) Click [OK] in the "Lock Bit Disable...finish" dialog to close the dialog.

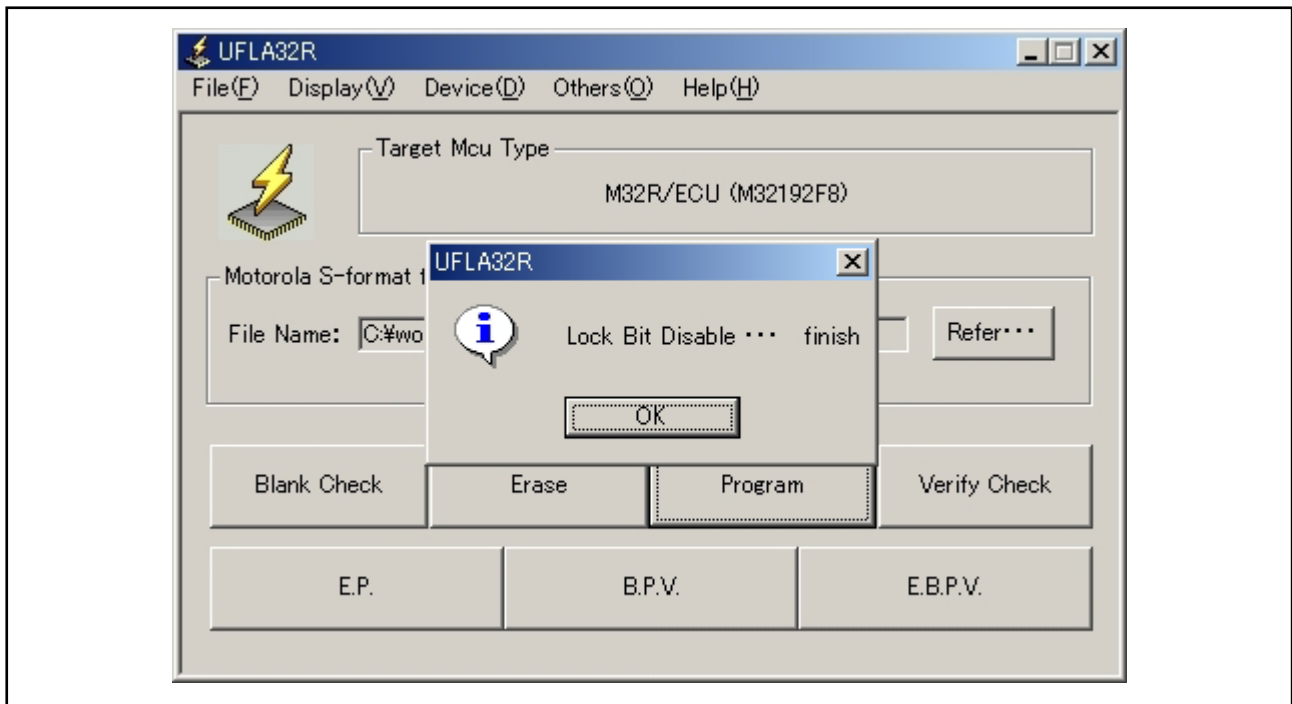

Figure 5.10.2 Lock Bit Disable Finish Dialog

5.11 Blank Check

- (1) Choose [Blank Check(B)] from [Device(D)] menu or click [Blank Check] button to display the dialog that shows execution process, and then perform blank check operation. After completing blank check, the dialog is closed and "Blank Check...finish" dialog is displayed.

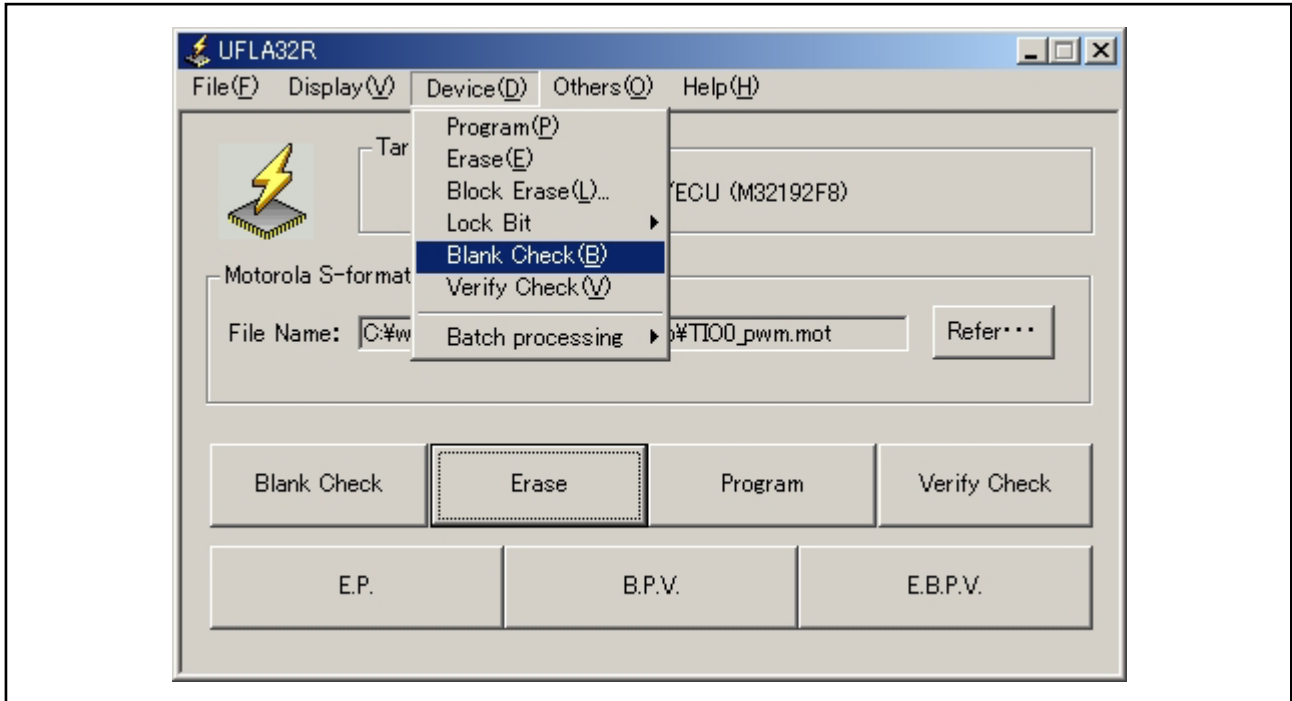

Figure 5.11.1 Blank Check

- (2) Click [OK] in the "Blank Check...finish" dialog to close the dialog.

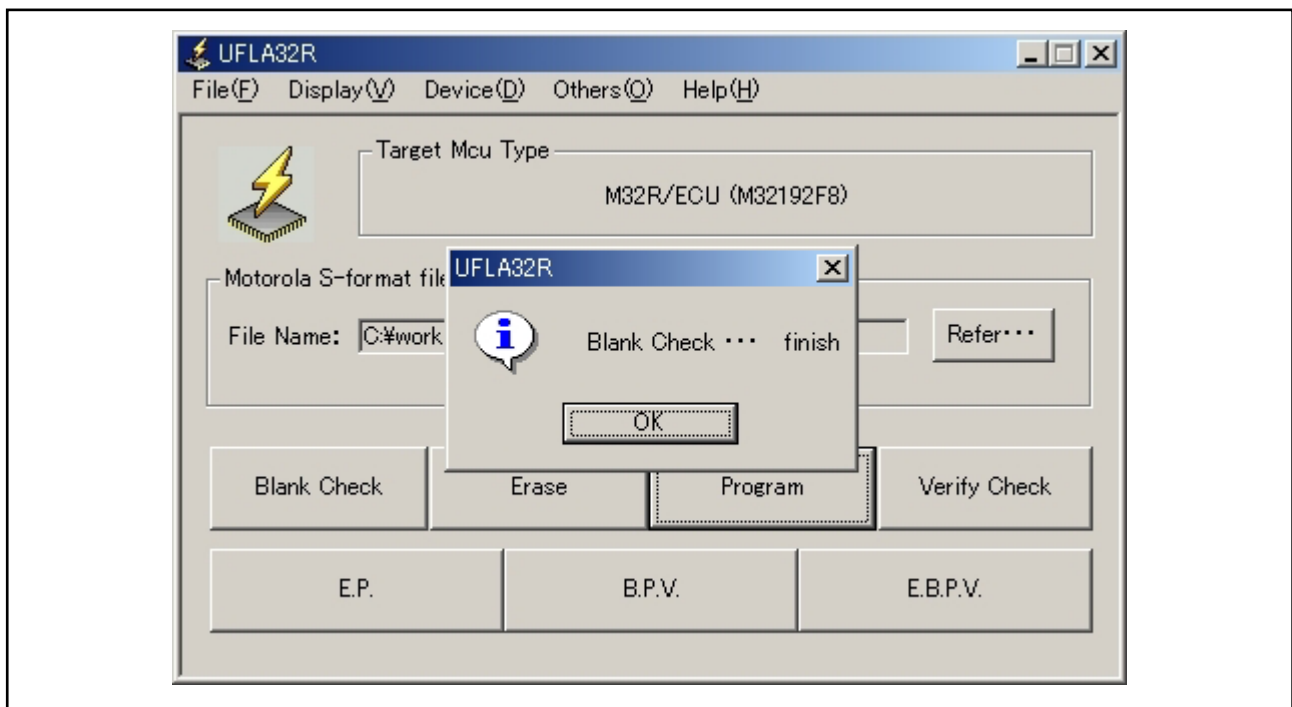

Figure 5.11.2 Blank Check Finish Dialog

5.12 Verify Check

- (1) Choose [Verify Check(V)] from [Device(D)] menu or click [Verify Check] button to display the dialog that shows execution process, and then perform verify check operation. After completing verify check, the dialog is closed and "Verify Check...finish" dialog is displayed.

Note: When [Sum check (high speed)] is chosen from [Verify Process (V)] in [Others (O)]-[Setting(S)] dialog, the data in the MCU is compared to the check sum value of the program data file. When [Read array (high reliability)] is selected, the data in the MCU is compared to the program data file by the byte.

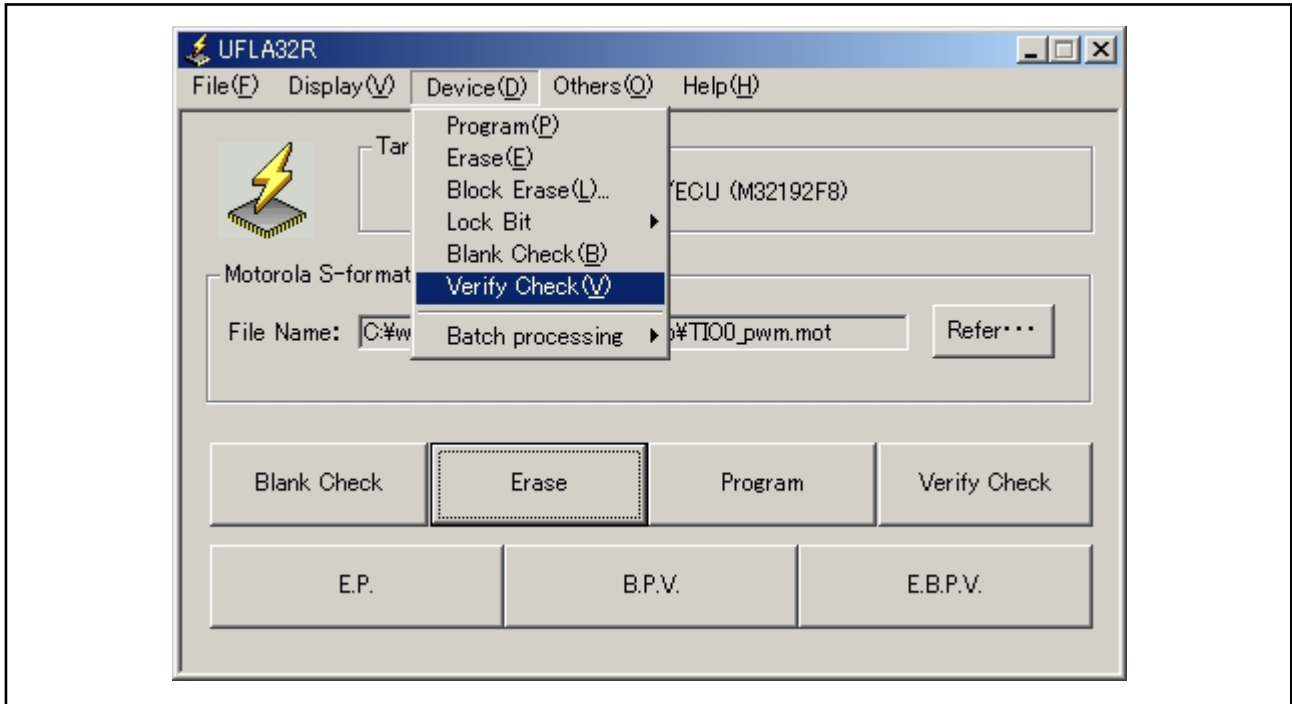

Figure 5.12.1 Verify Check

- (2) Click [OK] in the "Verify Check...finish" dialog box to close the dialog.

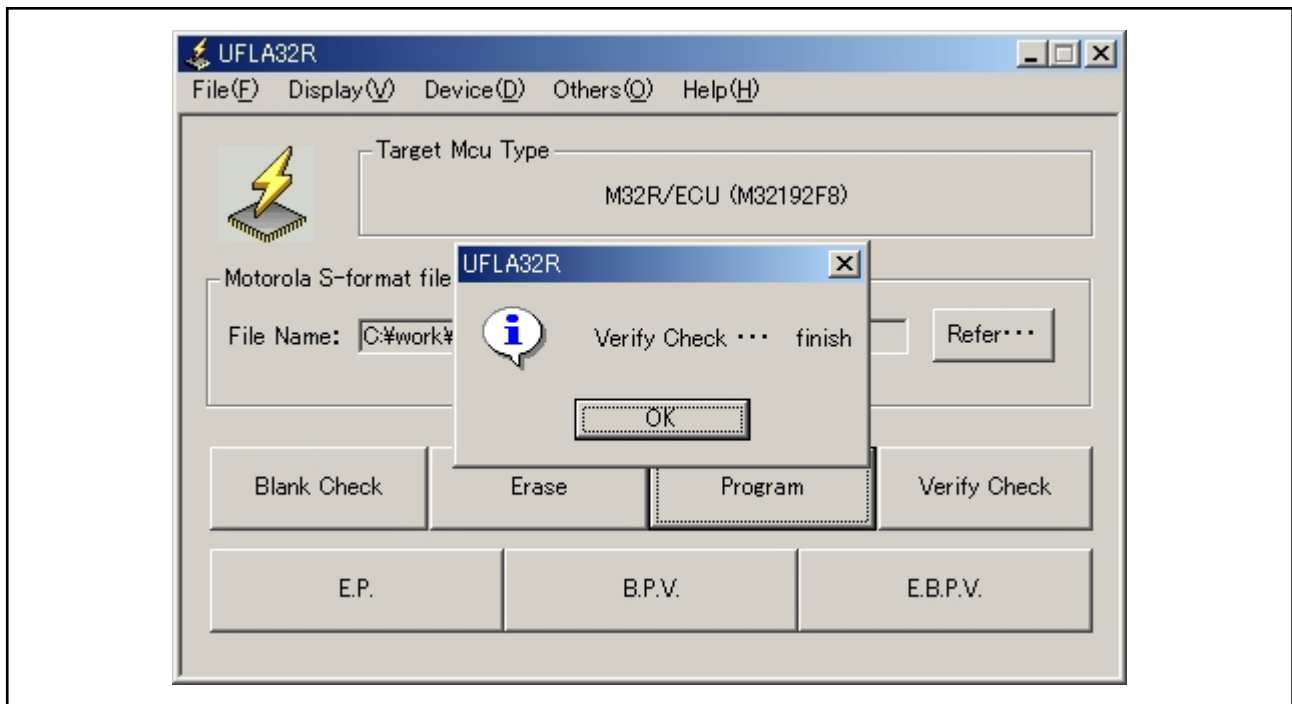

Figure 5.12.2 Verify Check Finish Dialog

5.13 E.B.P.V. (Erase, Blank Check, Program, Verify Check)

- (1) Choose [Batch Processing]-[E.B.P.V.] from [Device(D)] menu or click [E.B.P.V.] button to consecutively execute "Erase," "Blank Check," "Program," and "Verify Check."

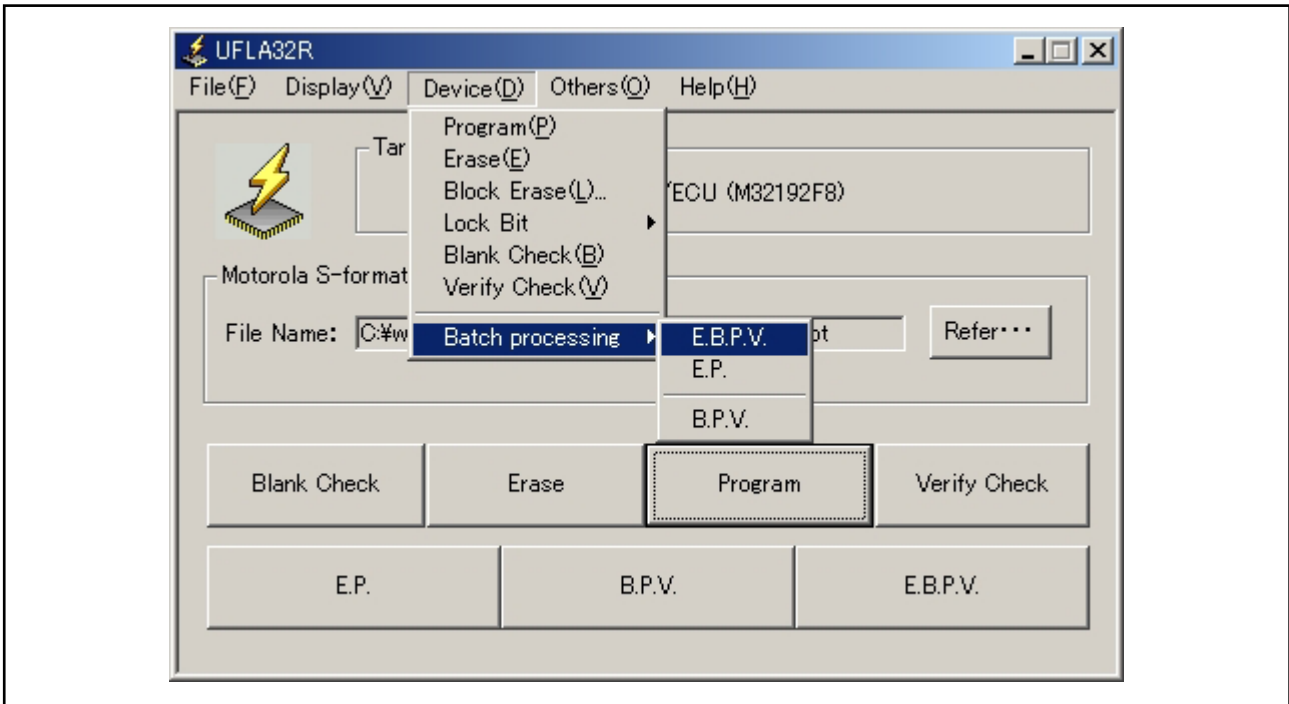

Figure 5.13.1 E.B.P.V.

5.14 E.P. (Erase, Program)

- (1) Choose [Batch Processing]-[E.P.] from [Device(D)] menu or click [E.P.] button to consecutively execute "Erase" and "Program."

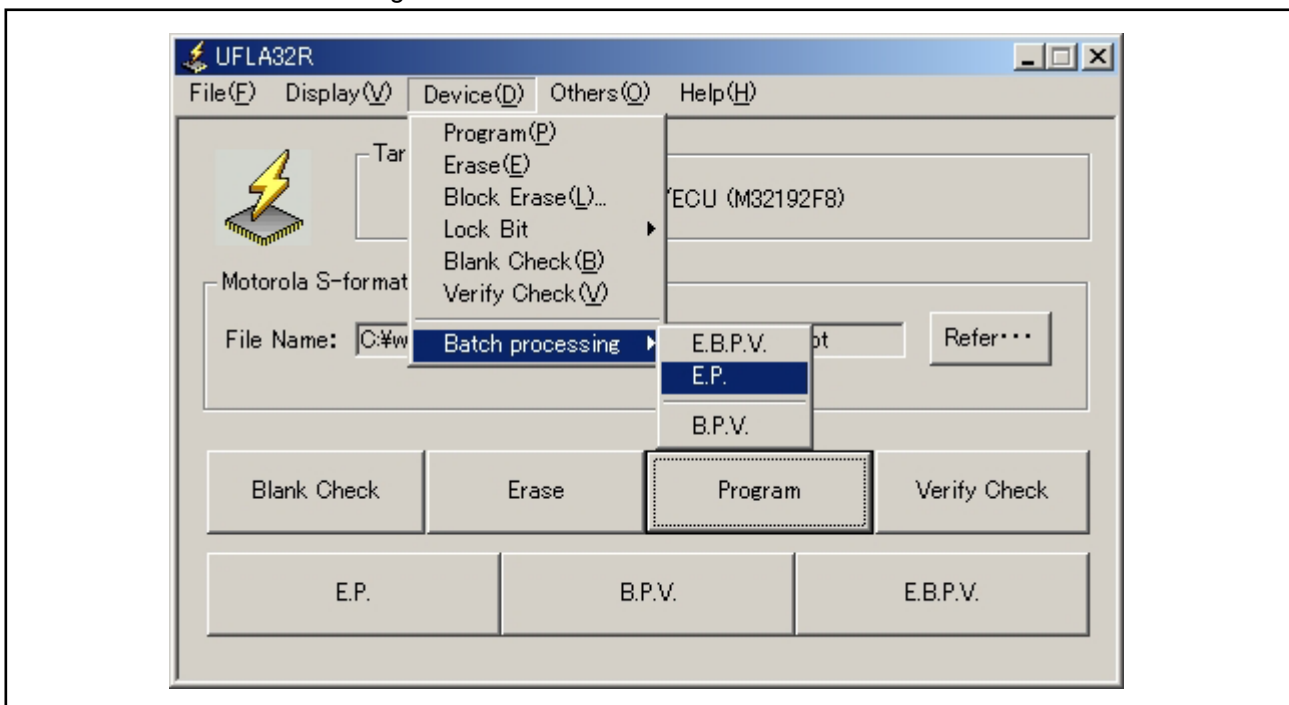

Figure 5.14.1 E.P.

5.15 B.P.V. (Blank Check, Program, Verify Check)

- (1) Choose [Batch Processing]-[B.P.V.] from [Device(D)] menu or click [B.P.V.] button to consecutively execute "Blank Check," "Program," and "Verify Check."

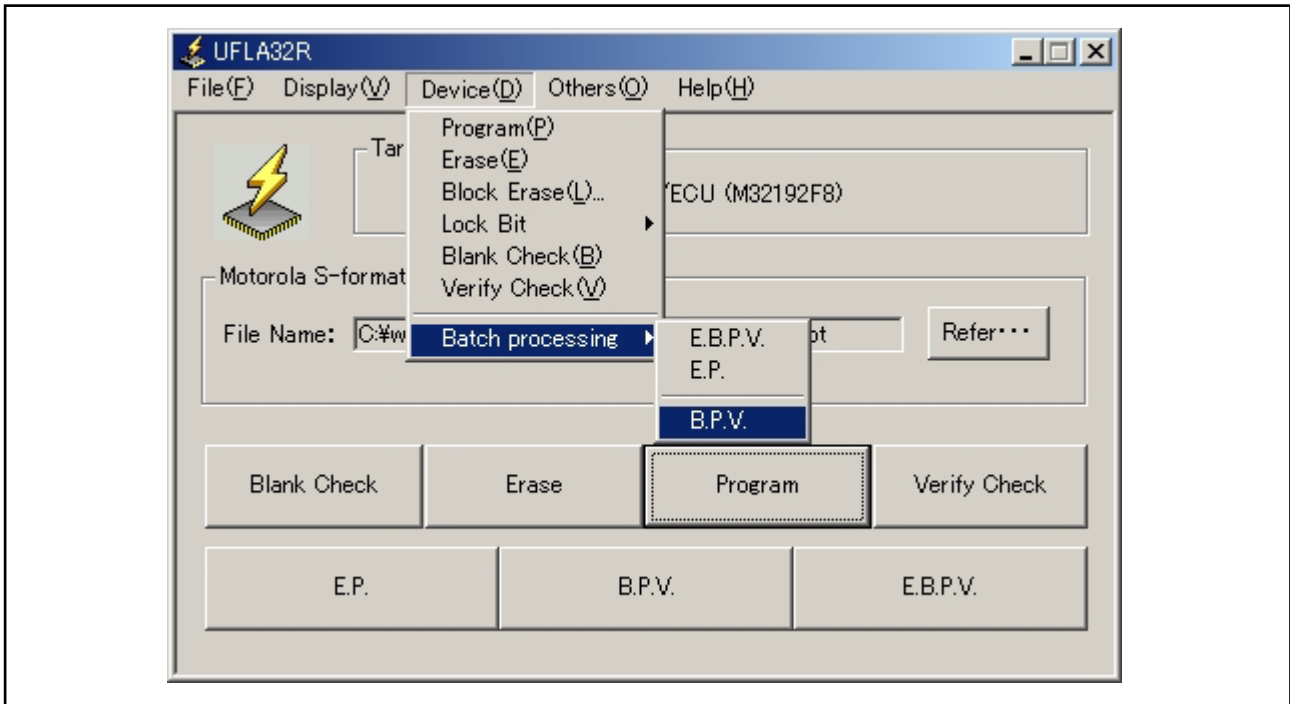

Figure 5.15.1 B.P.V.

5.16 Setting

- (1) Choose [Setting(S)] from [Others(O)] menu to display "Setup" dialog.

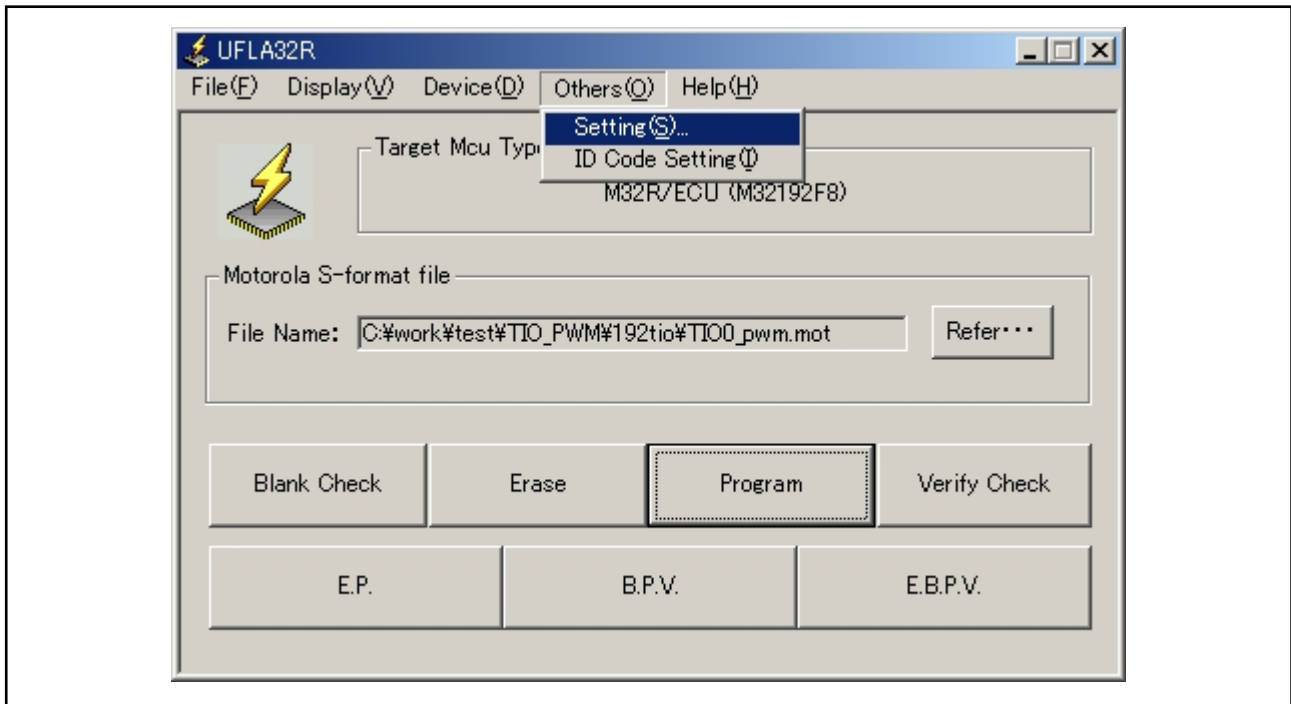

Figure 5.16.1 Setting

- (2) In the "Setup" dialog, it is possible to choose MCU type, verify process, and write ID code into the ID code area.

It is possible to choose MCU from "Mcu Type(M)" pull-down menu.

It is possible to choose verify check process from "Verify process(V).".

Choose [Sum check (high speed)] to compare the data in MCU to the check sum value of the program data file.

Choose [Read array (high reliability)] to compare the data in MCU to the program data file by the byte.

Choose [Permit to write ID code into Target MCU] to write data into ID code area of the MCU at the time of program. If it is not chosen, ID code area of the MCU is filled with FFh.

Write the data other than FFh into ID code area to enable protect function of the flash memory. When protect function is enabled, the ID code is verified before executing operation to the flash memory (erase or write). When the ID code is not corresponding as a result of verification, the operation to the flash memory is not available.

When the whole area of the ID code is filled with FFh, the ID code is not verified.

Note: At the time of the M3S-UFLA32R startup, previously chosen MCU is set to "MCU Type(M)". However, [Sum check (high speed)] is checked at "Verify process(V)" and [Permit to write ID code into Target MCU] is unchecked.

Click [OK] to enable the setting, and then close the "Setup" dialog.

Click [Cancel] to disable the setting, and then close the "Setup" dialog.

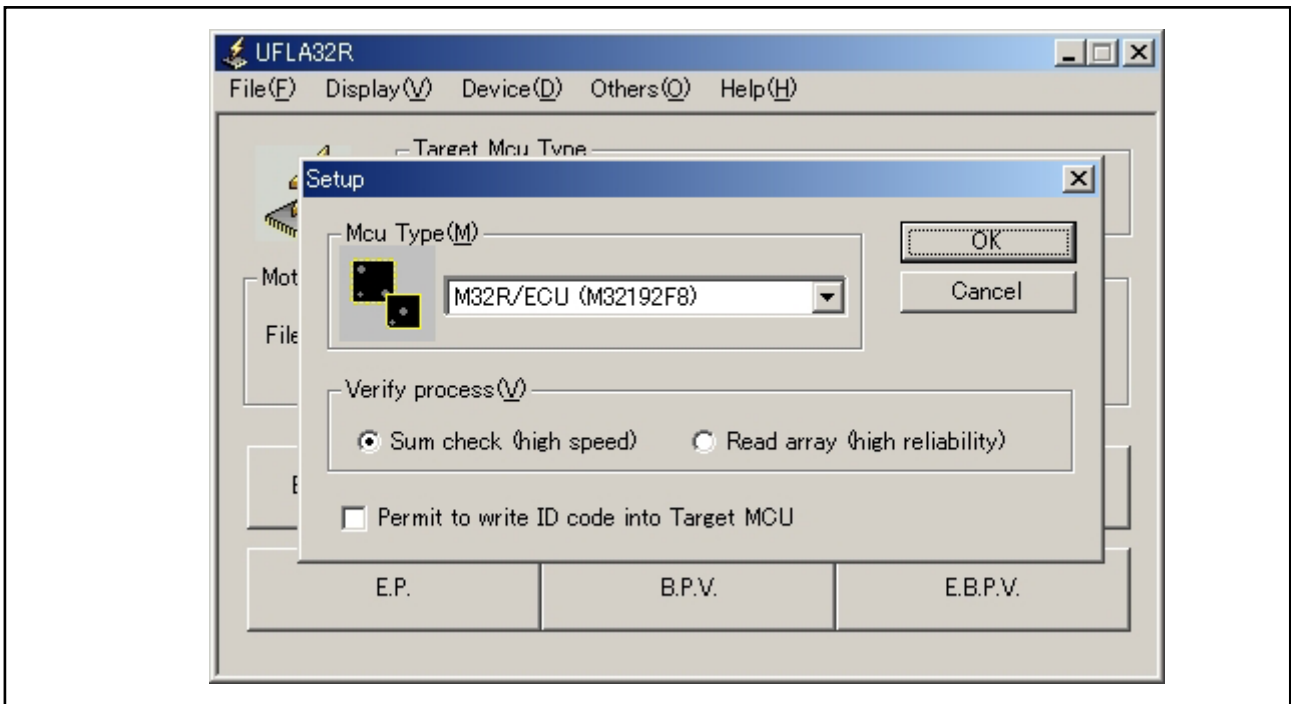

Figure 5.16.2 Setup Dialog

5.17 ID Code Setting

- (1) Choose [ID Code Setting(L)] from [Others(O)] menu to display "ID code setting" dialog.

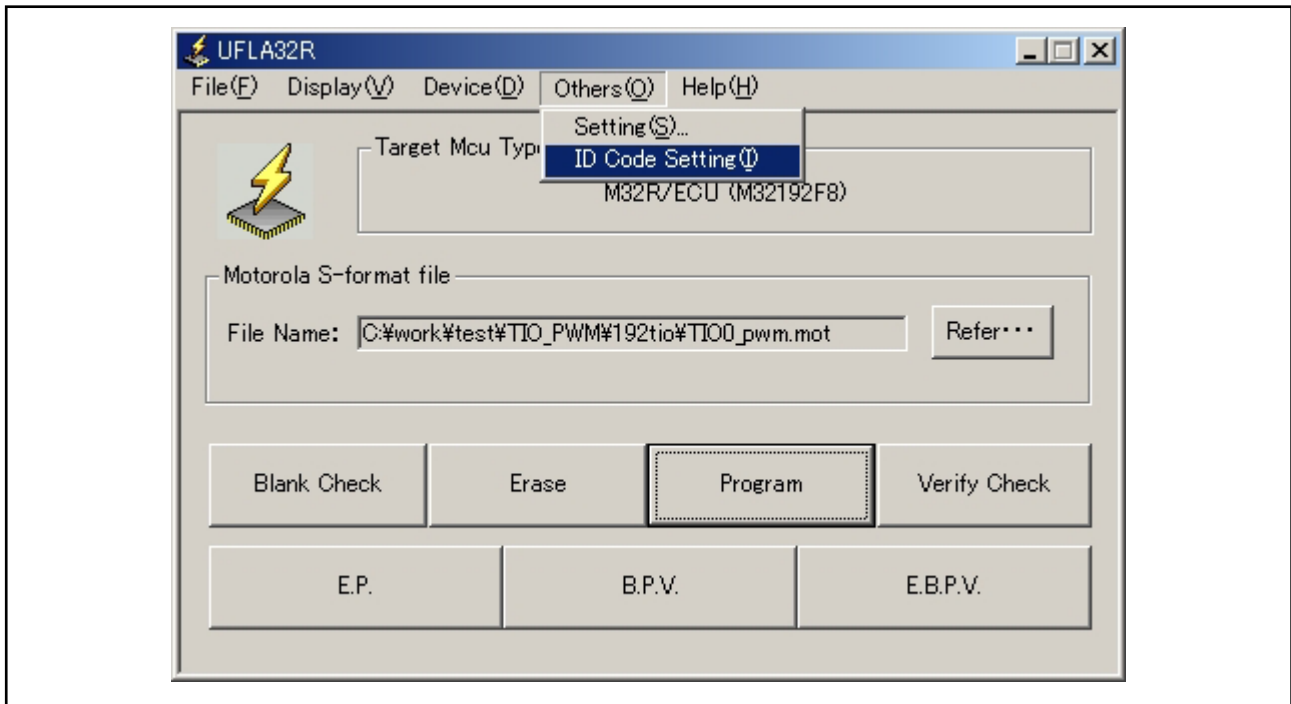

Figure 5.17.1 ID Code Setting

- (2) In the "ID code setting" dialog, the ID code for verification is set.
 Table 5.17.1 shows function list of operable and not operable functions according with the verify result.
 Choose [Specify ID code by hexadecimal] to set the ID code by hexadecimal.
 Choose [Specify ID code by alphanumeric] to set the ID code by alphanumeric characters.
 Click [OK] to enable the setting, and then close the "ID code setting" dialog.
 Click [Cancel] to disable the setting, and then close the "ID code setting" dialog.

Note: In the 3218x Group and 3219x Group, 12-byte of the address H'84 to H'8F is enabled.
 In the other MCU, 16-byte of the address H'84 to H'93 is enabled.

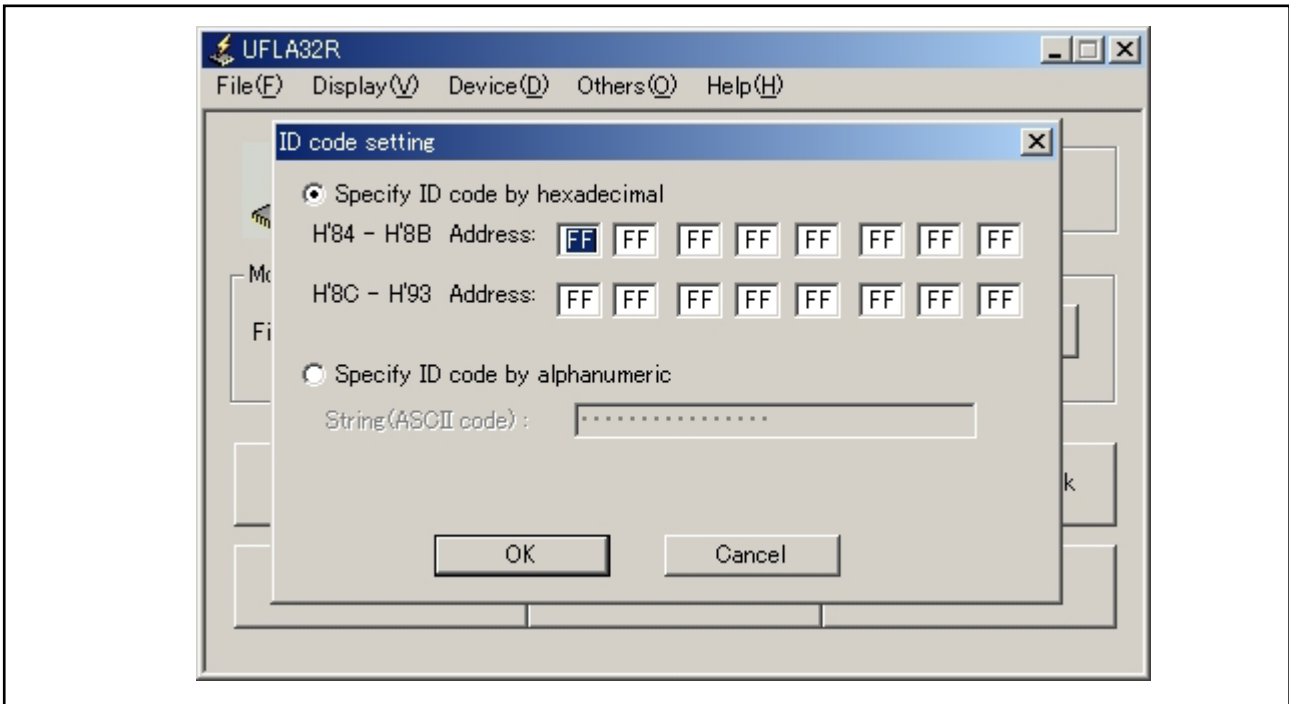

Figure 5.17.2 ID Code Setting Dialog

Table 5.17.1 Operable, Not Operable List

Function	ID code is corresponding or every ID code in the MCU is FFh	ID code is not corresponding
Load	YES	YES
Exit	YES	YES
Lock Bit Information	YES	NO
Program	YES	NO
Erase	YES	NO
Block Erase	YES	NO
Lock Bit / Set	YES	NO
Lock Bit / Enable	YES	NO
Lock Bit / Disable	YES	NO
Blank Check	YES	NO
Verify Check	YES	NO
Batch processing / E.B.P.V.	YES	NO
Batch processing / E.P.	YES	NO
Batch processing / B.P.V.	YES	NO
Setting	YES	YES
ID Code Setting	YES	YES
Version information	YES	YES

Note: YES: Operable, NO: Not operable

5.18 Version Information

- (1) Choose [Version information (UFLA32R) (A)] from [Help(H)] menu to display "Version information (UFLA32R)" dialog.

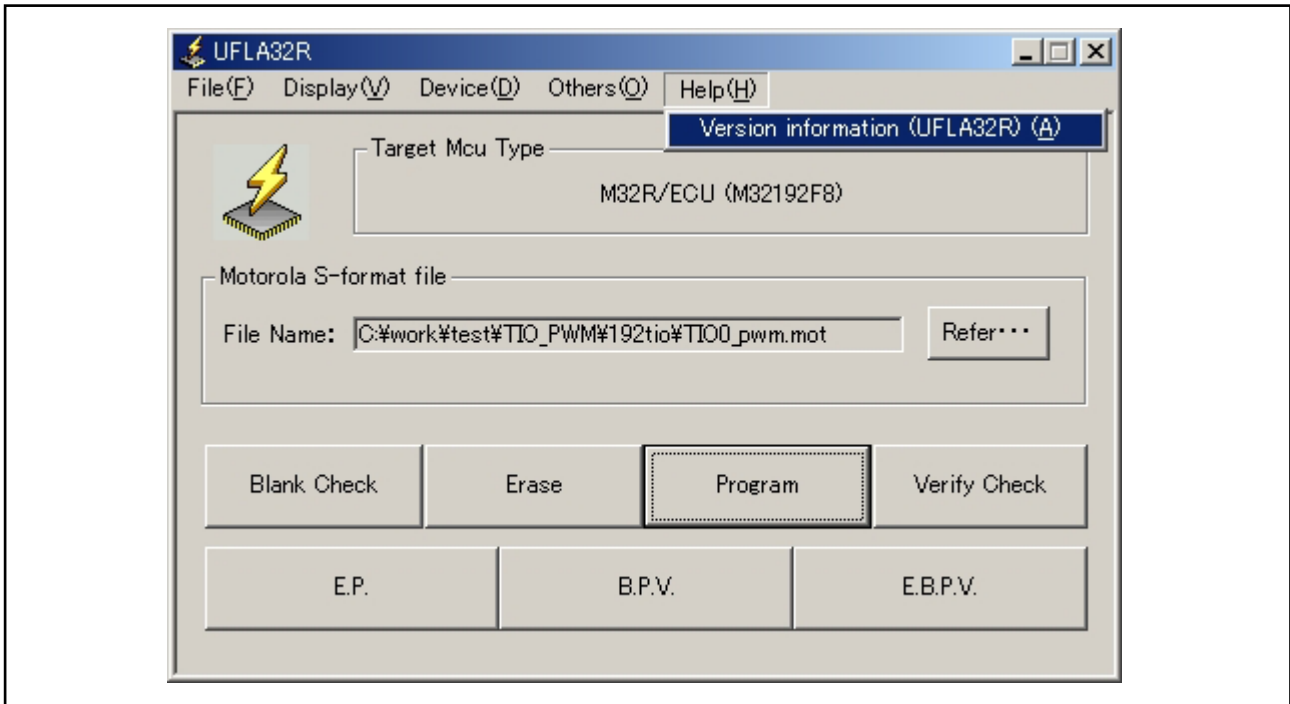

Figure 5.18.1 Version Information

- (2) In the "Version information (UFLA32R)" dialog, the M3S-UFLA32R version and Flash E/W Firmware version in the MCU are displayed. Click [OK] to close the dialog.

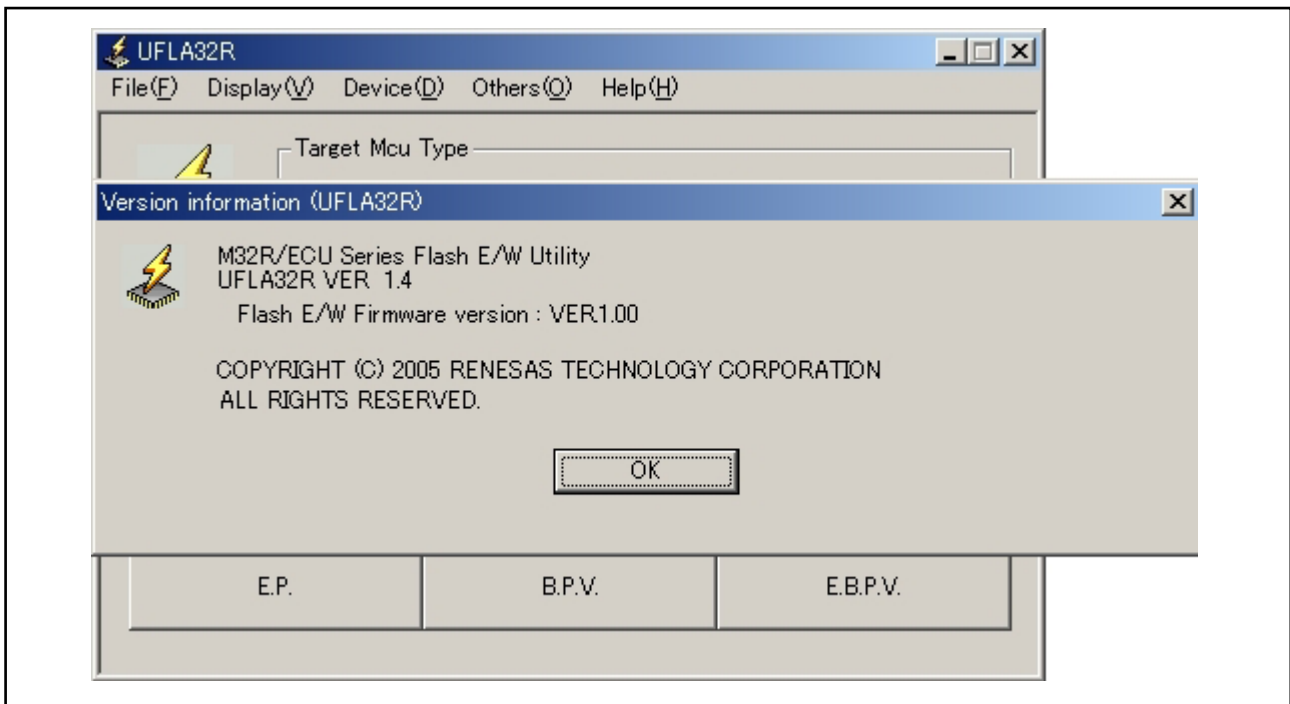

Figure 5.18.2 Version Information (UFLA32R) Dialog

6. Error Message List

Table 6.1.1 lists error messages, causes, and approaches provided from the M3S-UFLA32R.

Table 6.1.1 Error Message List

	Error Message	Cause	Approach
1	MCU information is incorrect. Please check whether the "UFLA32R.ini" file is installed correctly.	There is no INI file.	Reinstall the M3S-UFLA32R.
2	Can not open COM1.	Can not open COM1.	Check if the COM1 is used in the other application.
3	Motorola file is not specified. Please specify Motorola file.	Motorola S format file is not specified.	Specify the Motorola S format file.
4	The specified file is not a S-format file. Please specify S-format file (*.mot).	The specified file is not Motorola S-format file or there are some contents errors.	Check the contents of the selected file or specify different file.
5	Address Error. Start Address < NNNNNNNNh	The data record address of chosen file is beyond the flash memory.	Check the contents of Motorola S format file or specify different file.
6	Address Error. End Address > NNNNNNNNh	The record length of the chosen file has an error.	Check the contents of Motorola S format file or specify different file.
7	Receive timeout error.	Timeout occurs during reception.	Check the connection state of the communication cable or restart the M3S-UFLA32R, and then reset the MCU.
8	Communication parameter error.	Receive reply other than ACK and NAK from the MCU.	Restart the M3S-UFLA32R and reset the MCU.
9	Command execution error.	Receive NAK from the MCU.	Restart the M3S-UFLA32R and reset the MCU.
10	Blank Check Error. (Error Address: H'NNNNNN)	There is no blank after the address H'NNNNNN.	-
11	Verify Check Error. Error Address : H'NNNNNN Error Data : H'AAAA (H'BBBB)	At the time of verify, the data of the address H'NNNNNN are H'AAAA (MCU side) and H'BBBB (M3S-UFLA32R side) and not corresponding.	Check if it is the same Motorola S format file as the program in the MCU.
12	Verify Check Error.	Check sum value is not corresponding at the time of verification	Check if it is the same Motorola S format file as the program in the MCU.
13	ID verification error. Please set up the ID code correctly.	The ID code in the MCU and the one set in the M3S-UFLA32R are different	Set the correct ID code to the M3S-UFLA32R.
14	ID code is incorrect. Please enter ID code with Hexadecimal.	Input ID code has an error.	Enter ID code with Hexadecimal.
15	ID code is incorrect. Please enter ID code correctly.	Input ID code has an error.	Enter ID code with alphanumeric characters.

Revision History	M3S-UFLA32R UART Flash Memory Programming Utility
------------------	------------------------------------------------------

Rev.	Date	Description	
		Page	Summary
1.00	Jun 25, 2000	-	First edition issued.
1.01	Dec 4, 2000	-	Changed output message from Japanese to English.
1.02	Jan 29, 2002	7	Added references to 2) Connecting Host PC with Target System in Chapter 3. Changed product name from UFLA32 to M3A-UFLA32R.
1.03	Feb 14, 2002	7	Changed the description of 2) Connecting Host PC with Target System in Chapter 3.
1.04	Mar 1, 2002	2	Added "Notes regarding these materials."
1.10	Oct 28, 2002	6	Added description to 1) Setting up M3S-UFLA32R in Chapter 3.
1.20	Dec 3, 2002	6	Changed the location where "Setup.exe" is stored in a CD-ROM.
1.30	Jul 11, 2003	-	Changed the layout of window. Supported 32176/32180/32182 Group MCUs.
1.40	Mar 6, 2007	-	Supported 32185/32186 Group and 32192/32195/32196 Group MCUs. Reviewed overall contents.

**Uart Flash Memory Programming Utility
User's Manual
M3S-UFLA32R**

Publication Date: 1st Edition, Jun., 2000
Rev.1.40, Mar. 06, 2007
Published by: Sales Strategic Planning Div.
Renesas Technology Corp.

© 2007. Renesas Technology Corp., All rights reserved. Printed in Japan.

M3S-UFLA32R User's Manual



Renesas Electronics Corporation

1753, Shimonumabe, Nakahara-ku, Kawasaki-shi, Kanagawa 211-8668 Japan

REJ10B0239-0140