

To our customers,

Old Company Name in Catalogs and Other Documents

On April 1st, 2010, NEC Electronics Corporation merged with Renesas Technology Corporation, and Renesas Electronics Corporation took over all the business of both companies. Therefore, although the old company name remains in this document, it is a valid Renesas Electronics document. We appreciate your understanding.

Renesas Electronics website: <http://www.renesas.com>

April 1st, 2010
Renesas Electronics Corporation

Issued by: Renesas Electronics Corporation (<http://www.renesas.com>)

Send any inquiries to <http://www.renesas.com/inquiry>.

Notice

1. All information included in this document is current as of the date this document is issued. Such information, however, is subject to change without any prior notice. Before purchasing or using any Renesas Electronics products listed herein, please confirm the latest product information with a Renesas Electronics sales office. Also, please pay regular and careful attention to additional and different information to be disclosed by Renesas Electronics such as that disclosed through our website.
2. Renesas Electronics does not assume any liability for infringement of patents, copyrights, or other intellectual property rights of third parties by or arising from the use of Renesas Electronics products or technical information described in this document. No license, express, implied or otherwise, is granted hereby under any patents, copyrights or other intellectual property rights of Renesas Electronics or others.
3. You should not alter, modify, copy, or otherwise misappropriate any Renesas Electronics product, whether in whole or in part.
4. Descriptions of circuits, software and other related information in this document are provided only to illustrate the operation of semiconductor products and application examples. You are fully responsible for the incorporation of these circuits, software, and information in the design of your equipment. Renesas Electronics assumes no responsibility for any losses incurred by you or third parties arising from the use of these circuits, software, or information.
5. When exporting the products or technology described in this document, you should comply with the applicable export control laws and regulations and follow the procedures required by such laws and regulations. You should not use Renesas Electronics products or the technology described in this document for any purpose relating to military applications or use by the military, including but not limited to the development of weapons of mass destruction. Renesas Electronics products and technology may not be used for or incorporated into any products or systems whose manufacture, use, or sale is prohibited under any applicable domestic or foreign laws or regulations.
6. Renesas Electronics has used reasonable care in preparing the information included in this document, but Renesas Electronics does not warrant that such information is error free. Renesas Electronics assumes no liability whatsoever for any damages incurred by you resulting from errors in or omissions from the information included herein.
7. Renesas Electronics products are classified according to the following three quality grades: “Standard”, “High Quality”, and “Specific”. The recommended applications for each Renesas Electronics product depends on the product’s quality grade, as indicated below. You must check the quality grade of each Renesas Electronics product before using it in a particular application. You may not use any Renesas Electronics product for any application categorized as “Specific” without the prior written consent of Renesas Electronics. Further, you may not use any Renesas Electronics product for any application for which it is not intended without the prior written consent of Renesas Electronics. Renesas Electronics shall not be in any way liable for any damages or losses incurred by you or third parties arising from the use of any Renesas Electronics product for an application categorized as “Specific” or for which the product is not intended where you have failed to obtain the prior written consent of Renesas Electronics. The quality grade of each Renesas Electronics product is “Standard” unless otherwise expressly specified in a Renesas Electronics data sheets or data books, etc.
 - “Standard”: Computers; office equipment; communications equipment; test and measurement equipment; audio and visual equipment; home electronic appliances; machine tools; personal electronic equipment; and industrial robots.
 - “High Quality”: Transportation equipment (automobiles, trains, ships, etc.); traffic control systems; anti-disaster systems; anti-crime systems; safety equipment; and medical equipment not specifically designed for life support.
 - “Specific”: Aircraft; aerospace equipment; submersible repeaters; nuclear reactor control systems; medical equipment or systems for life support (e.g. artificial life support devices or systems), surgical implantations, or healthcare intervention (e.g. excision, etc.), and any other applications or purposes that pose a direct threat to human life.
8. You should use the Renesas Electronics products described in this document within the range specified by Renesas Electronics, especially with respect to the maximum rating, operating supply voltage range, movement power voltage range, heat radiation characteristics, installation and other product characteristics. Renesas Electronics shall have no liability for malfunctions or damages arising out of the use of Renesas Electronics products beyond such specified ranges.
9. Although Renesas Electronics endeavors to improve the quality and reliability of its products, semiconductor products have specific characteristics such as the occurrence of failure at a certain rate and malfunctions under certain use conditions. Further, Renesas Electronics products are not subject to radiation resistance design. Please be sure to implement safety measures to guard them against the possibility of physical injury, and injury or damage caused by fire in the event of the failure of a Renesas Electronics product, such as safety design for hardware and software including but not limited to redundancy, fire control and malfunction prevention, appropriate treatment for aging degradation or any other appropriate measures. Because the evaluation of microcomputer software alone is very difficult, please evaluate the safety of the final products or system manufactured by you.
10. Please contact a Renesas Electronics sales office for details as to environmental matters such as the environmental compatibility of each Renesas Electronics product. Please use Renesas Electronics products in compliance with all applicable laws and regulations that regulate the inclusion or use of controlled substances, including without limitation, the EU RoHS Directive. Renesas Electronics assumes no liability for damages or losses occurring as a result of your noncompliance with applicable laws and regulations.
11. This document may not be reproduced or duplicated, in any form, in whole or in part, without prior written consent of Renesas Electronics.
12. Please contact a Renesas Electronics sales office if you have any questions regarding the information contained in this document or Renesas Electronics products, or if you have any other inquiries.

(Note 1) “Renesas Electronics” as used in this document means Renesas Electronics Corporation and also includes its majority-owned subsidiaries.

(Note 2) “Renesas Electronics product(s)” means any product developed or manufactured by or for Renesas Electronics.

M3T-PD38SIM V.2.10

User's Manual

Simulator Debugger for 740 Family

- Microsoft, MS-DOS, Windows, and Windows NT are registered trademarks of Microsoft Corporation in the U.S. and other countries.
- IBM and AT are registered trademarks of International Business Machines Corporation.
- Intel and Pentium are registered trademarks of Intel Corporation.
- Adobe, Acrobat, and Acrobat Reader are trademarks of Adobe Systems Incorporated.
- All other brand and product names are trademarks, registered trademarks or service marks of their respective holders.

Keep safety first in your circuit designs!

- Renesas Technology Corporation and Renesas Solutions Corporation put the maximum effort into making semiconductor products better and more reliable, but there is always the possibility that trouble may occur with them. Trouble with semiconductors may lead to personal injury, fire or property damage. Remember to give due consideration to safety when making your circuit designs, with appropriate measures such as (i) placement of substitutive, auxiliary circuits, (ii) use of nonflammable material or (iii) prevention against any malfunction or mishap.

Notes regarding these materials

- These materials are intended as a reference to assist our customers in the selection of the Renesas Technology product best suited to the customer's application; they do not convey any license under any intellectual property rights, or any other rights, belonging to Renesas Technology Corporation, Renesas Solutions Corporation or a third party.
- Renesas Technology Corporation and Renesas Solutions Corporation assume no responsibility for any damage, or infringement of any third-party's rights, originating in the use of any product data, diagrams, charts, programs, algorithms, or circuit application examples contained in these materials.
- All information contained in these materials, including product data, diagrams, charts, programs and algorithms represents information on products at the time of publication of these materials, and are subject to change by Renesas Technology Corporation and Renesas Solutions Corporation without notice due to product improvements or other reasons. It is therefore recommended that customers contact Renesas Technology Corporation, Renesas Solutions Corporation or an authorized Renesas Technology product distributor for the latest product information before purchasing a product listed herein. The information described here may contain technical inaccuracies or typographical errors. Renesas Technology Corporation and Renesas Solutions Corporation assume no responsibility for any damage, liability, or other loss rising from these inaccuracies or errors. Please also pay attention to information published by Renesas Technology Corporation and Renesas Solutions Corporation by various means, including the Renesas home page (<http://www.renesas.com>).
- When using any or all of the information contained in these materials, including product data, diagrams, charts, programs, and algorithms, please be sure to evaluate all information as a total system before making a final decision on the applicability of the information and products. Renesas Technology Corporation and Renesas Solutions Corporation assume no responsibility for any damage, liability or other loss resulting from the information contained herein.
- Renesas Technology semiconductors are not designed or manufactured for use in a device or system that is used under circumstances in which human life is potentially at stake. Please contact Renesas Technology Corporation, Renesas Solutions Corporation or an authorized Renesas Technology product distributor when considering the use of a product contained herein for any specific purposes, such as apparatus or systems for transportation, vehicular, medical, aerospace, nuclear, or undersea repeater use.
- The prior written approval of Renesas Technology Corporation and Renesas Solutions Corporation is necessary to reprint or reproduce in whole or in part these materials.
- If these products or technologies are subject to the Japanese export control restrictions, they must be exported under a license from the Japanese government and cannot be imported into a country other than the approved destination. Any diversion or reexport contrary to the export control laws and regulations of Japan and/or the country of destination is prohibited.
- Please contact Renesas Technology Corporation or Renesas Solutions Corporation for further details on these materials or the products contained therein.

For inquiries about the contents of this document or product, fill in the text file the installer generates in the following directory and email to your local distributor.

¥SUPPORT¥Product-name¥SUPPORT.TXT

Renesas Tools Homepage <http://www.renesas.com/en/tools>

Preface

The PD38SIM is a simulator debugger for Windows, which simulates the 740 family operation of 8-bit microcomputer and evaluates the target program. This user's manual describes the PD38SIM's features, functions, setting up and operational procedures.

Rights to the Program

The right to use the program is granted according to provisions under a software license agreement. The PD38SIM program can only be used for the purposes of product development by the user, and cannot be used for any other purposes.

Note also that the information in this manual does not convey any guarantee or license for the use of software.

[MEMO]

Contents

INTRODUCTION	1
1 PD38SIM INTRODUCTION	3
2 PD38SIM FEATURES	4
2.1 Multi-Windowing Function	4
2.2 I/O Simulation Function	4
2.3 Interrupt Simulation Function	4
2.4 Simplified System Simulation Function	4
2.5 RAM Monitor Function	4
2.6 Break Functions	5
2.7 Source Level Debugging Function	5
2.8 On-Demand Method	6
3 PD38SIM SIMULATION SPECIFICATIONS	7
3.1 Main Differences to Actual MCU	7
3.2 Operation of Instructions	8
3.3 Resetting	8
3.4 Memory	9
3.5 Virtual Port Input Function	9
3.6 Virtual Port Output Function	9
3.7 Virtual Interrupt Function	10
3.8 GUI Input Function	10
3.9 GUI Output Function	11
3.10 I/O Script Function	11
3.11 Unique Simulator Functions	11
4 PD38SIM INPUT AND OUTPUT FILES	12
4.1 Input Files	12
4.2 Output Files	14
4.3 Temporary Files	15
SETUP	17

1 SETUP	19
1.1 Installation	19
1.2 Starting PD38SIM.....	19
1.3 PD38SIM Setup.....	20
1.4 sim38 Setup	23

WINDOW FUNCTION 25

1 WINDOW FUNCTION OF PD38SIM	27
1.1 The PD38SIM Window.....	27
1.2 Program Window.....	33
1.3 Source Window.....	38
1.4 Register Window	41
1.5 Memory Window	43
1.6 Dump Window.....	45
1.7 RAM Monitor Window.....	47
1.8 ASM Watch Window	50
1.9 C Watch Window.....	53
1.10 Local Window	56
1.11 File Local Window	58
1.12 Global Window	60
1.13 Script Window	61
1.14 I/O Window.....	63
1.15 GUI Input Window.....	80
1.16 GUI Output Window	82
1.17 Coverage Window.....	84
1.18 S/W Break Point Setting Dialog Box.....	87
1.19 H/W Break Point Setting Dialog Box.....	89

BASIC OPERATION 91

1 LOADING AND DISPLAYING THE TARGET PROGRAM	93
1.1 Downloading.....	93
1.2 To Reload the recent downloaded file	95
1.3 To download the target program automatically when updated	95
1.4 Changing Program Display Position Immediately After Downloading.....	96

1.5 Uploading	97
1.6 Saving Results of Disassembly.....	97
1.7 Continuing to Display a Selected Program Position.....	97
1.8 Changing the Program Display Position	98
1.9 Checking Source Programs in Other Directories	100
1.10 Mixing Source and Disassemble Displays.....	101
1.11 Displaying the Results of Disassembling.....	102
1.12 Changing Display Colors.....	103
2 STARTING AND STOPPING TARGET PROGRAM EXECUTION	104
2.1 Starting and Stopping.....	104
2.2 Step Execution.....	105
2.3 Returning from Current to Calling Routine	106
2.4 Program Execution to Specified Location	107
2.5 Resetting the Program	107
3 CHECKING AND SETTING REGISTER DATA AND MEMORY CONTENTS	108
3.1 Checking the Contents of Registers.....	108
3.2 Changing the Contents of Registers	109
3.3 Checking Changes in RAM During Target Program Execution.....	111
3.4 Checking the Value at a Specified Address	111
3.5 To switch scope.....	114
3.6 Setting Data at a Specified Address.....	114
3.7 Updating the Memory Display.....	116
3.8 To change the acquisition mode of the memory.....	116
4 SOFTWARE BREAKS	117
4.1 Opening the S/W Break Point Setting Dialog Box	117
4.2 Setting a Break Point.....	118
4.3 Deleting a Break Point.....	119
4.4 Temporarily Disabling Break Points	119
4.5 Temporarily Enabling Break Points	120
4.6 Setting a Break Point from Program (Source) Window.....	120
4.7 Setting Breakpoints from the Toolbar	121
4.8 Saving Breakpoints	121
4.9 Loading Breakpoints	121
5 HARDWARE BREAKS	122
5.1 Opening the H/W Break Point Setting Dialog Box.....	122

5.2 Setting Hardware Breakpoints	123
5.3 Deleting a Hardware Breakpoint.....	126
6 CHECKING C VARIABLES	127
6.1 Checking C Variables	127
6.2 To change the value of a C variable.....	130
7 SCRIPT COMMANDS	131
7.1 Executing Script Commands.....	131
7.2 Logging the Results of Executing Script Commands.....	132
7.3 Executing Script Commands in Batch Mode	135
8 EXITING PD38SIM	137
8.1 Exiting PD38SIM	137
9 MISCELLANEOUS	138
9.1 Line Assemble	138
9.2 Starting Up Make.....	140
9.3 Searching for Character Strings in Target Program.....	141
9.4 Changing Window Proportions	142
9.5 Switching Over Active Windows.....	143
9.6 Displaying the Version of PD38SIM.....	143
9.7 To Configure the operation of the PD38SIM	144
9.8 To Open the Editor.....	144

HIGH-END DEBUGGING	145
---------------------------	------------

1 SETTING VIRTUAL PORT INPUTS IN I/O WINDOW	147
1.1 Overview.....	147
1.2 Setting Cycle-synchronized Inputs	147
1.3 Setting Read Access-synchronized Inputs	150
1.4 Setting Interrupt-synchronized Inputs.....	152
2 SETTING VIRTUAL PORT OUTPUTS IN I/O WINDOW	156
2.1 Overview.....	156
2.2 Setting Virtual Port Outputs	156
3 SETTING VIRTUAL INTERRUPTS IN I/O WINDOW	158
3.1 Overview.....	158
3.2 Setting Cycle-synchronized Interrupts.....	158

3.3 Setting Executed Address-synchronized Interrupts.....	161
4 OTHER FUNCTIONS OF I/O WINDOW	164
4.1 Changing Setup Data of Virtual Port Inputs and Virtual Interrupts.....	164
4.2 Deleting Virtual Port Inputs, Virtual Port Outputs, Virtual Interrupts, or I/O Script Files Set.....	169
4.3 Changing Display Mode of Virtual Port Input, Virtual Port Output, or Virtual Interrupt.....	174
4.4 Changing Scale of Display Screen	175
4.5 Changing Colors of Display Screen.....	176
4.6 Searching for Display Data.....	177
4.7 Listing Registered I/O Script Files.....	178
4.8 Regarding Evaluation Timings of Virtual Port Inputs, Virtual Interrupts, and I/O Script Files Set.....	178
5 SETTING GUI INPUT WINDOW	179
5.1 Overview.....	179
5.2 Creating Buttons.....	179
5.3 Saving Buttons You've Created	181
5.4 Changing Button Position or Settings after Creating Button.....	182
5.5 Copying buttons	183
5.6 Deleting buttons.....	184
5.7 Displaying Grid Lines	184
6 SETTING GUI OUTPUT WINDOW	185
6.1 Overview.....	185
6.2 Creating Labels	185
6.3 Creating LEDs.....	189
6.4 Saving Parts You've Created	192
6.5 Changing Parts Position or Settings after Creating Parts.....	192
6.6 Copying Parts.....	193
6.7 Deleting Parts	193
6.8 Displaying Grid Lines	194
7 I/O SCRIPT FUNCTION	195
7.1 Overview.....	195
7.2 Method for Writing I/O Script.....	195
7.3 Composition of I/O Script	196
7.4 Method for Writing Right-side Expressions.....	200
7.5 Method for Writing Left-side Expressions.....	203

8 COVERAGE INFORMATION	205
8.1 Referencing Coverage.....	205
8.2 Updating Coverage Display	205
8.3 Initializing Coverage.....	205
8.4 Saving/Loading Coverage Measurement Information.....	206
9 CUSTOMIZE FUNCTION	207
9.1 About Customize Function.....	207

REFERENCE	211
------------------	------------

1 TABLE OF SCRIPT COMMANDS	213
1.1 Input Format.....	213
1.2 Tables of Commands	214
2 WRITING SCRIPT FILES	223
2.1 Structural Elements of a Script File.....	223
2.2 Writing Expressions.....	225
3 C EXPRESSIONS	230
3.1 Writing C Expressions	230
3.2 Display Format of C Expressions.....	233
4 ERROR MESSAGES	238

INDEX	249
--------------	------------

Introduction

1 PD38SIM Introduction

The PD38SIM is a simulator debugger for Windows, which simulates the 740 family operation of 8-bit microcomputer and evaluates the target program.

PD38SIM comprises the following software:

1. pd38sim (the simulator debugger front end)
2. sim38 (the simulator engine)

2 PD38SIM Features

2.1 Multi-Windowing Function

PD38SIM supports multiple overlapping windows, enabling you to simultaneously view a wide range of data. Each window contains menus and buttons, allowing commands to be executed by clicking with the mouse.

2.2 I/O Simulation Function

PD38SIM provides the following I/O simulation functions:

- Virtual port input function
Changes of the data that is input from external devices to memory can be defined in the I/O Window or a file.
- Virtual port output function
The data that is output to memory by a program can be recorded. Changes of the recorded data can be graphically displayed.

2.3 Interrupt Simulation Function

Software interrupts can be defined. You can define the interrupts you want to be generated in the I/O Window or a file.

2.4 Simplified System Simulation Function

- GUI Input function
Key matrix can be defined by GUI.
- GUI output function
LEDs, etc. can be defined by GUI.

2.5 RAM Monitor Function

PD38SIM supports a RAM monitoring function, making it possible to check the contents of memory while executing the target program. The memory area monitored by this function is called the RAM monitor area. The PD38SIM have a 1KB RAM monitor area, which can be mapped to any address. You can use the RAM Monitor Window to monitor the RAM monitor area.

2.6 Break Functions

PD38SIM has the following four break functions:

2.6.1 Software Break

Software breaks allow program execution to be stopped before the command at the specified address. The point at which this break occurs is called the software breakpoint. You can set software breakpoints from the S/W Break Point Setting dialog box. You can also easily set them from the Program Window and Source Window. PD38SIM supports up to 64 software breakpoints. You can set and read in the software breakpoint file via the S/W Break Point Setting dialog box.

2.6.2 Hardware Break

Hardware breaks allow program execution to be stopped on detection of data being written to memory, read from memory, or an instruction being fetched. The point at which this break occurs is called the hardware breakpoint. You can set hardware breakpoints from the H/W Break Point Setting dialog box. PD38SIM supports up to 64 hardware breakpoints.

2.7 Source Level Debugging Function

You can display source files and perform source level debugging such as setting break points in the source lines and performing step execution. PD38SIM allows debugging at the C language level and at the assembly language level.

- You can use the Program Window and Source Window to view source files.
- You can use the C Watch Window, Local Window, File Local Window, and Global Window to view the C variables and C expressions in C source files.
- You can use the ASM Watch Window to view labels and symbols in assembler source files.
- You can use labels and symbols to specify the addresses of breakpoints, etc. First local, then global, labels and symbols are converted to values. When you specify variables (or functions) defined in a C source file, add the underbar (`_`) before the name of the variable (or function).

2.8 On-Demand Method

PD38SIM supports the "on-demand" method whereby a temporary file is created when a target program has been downloaded, and the required debugging information is read into memory as required. This method conserves memory. However, by default, PD38SIM uses the "on-memory" method, in which all debugging information is stored in memory.

Use the PD38SIM setup to select the "on-demand" or "on-memory" method of storing debugging information. See Section 1.3, "PD38SIM Setup" in the setup section of this manual for details.

Temporary files are created with the filename `pdb_xxxx.tmp` (where `xxxx` is a 4-digit hexadecimal value) in the directory containing the downloaded files. Temporary files are deleted immediately before downloading and when you quit PD38SIM. Select the "on-memory" method if there is any file with the same name as the temporary file.

Temporary files are created in the directory specified from the Init dialog box. If the specified directory contains a file of the same name as the temporary file, change the directory where you want the temporary file to be created or choose the "on-memory" method.

3 PD38SIM Simulation Specifications

3.1 Main Differences to Actual MCU

This section describes the main differences between PD38SIM and the actual MCU.

See later sections for details.

3.1.1 Realtime Timings

Time management by PD38SIM is performed in cycles. However, the following differs from the actual chip. Here, the number of cycles are indicated by values stipulated in 740 family Software Manual.

- The bus width, queue, and wait states are not considered when measuring the number of cycles.
- PD38SIM starts counting cycles immediately after a reset. (Cycles immediately after a reset are 0.) The number of cycles needed to execute one machine instruction are added on for each instruction executed. (See Figure 3.1 shown below.)

If two cycles are required for the LDA instruction, cycles are added at this point in time.

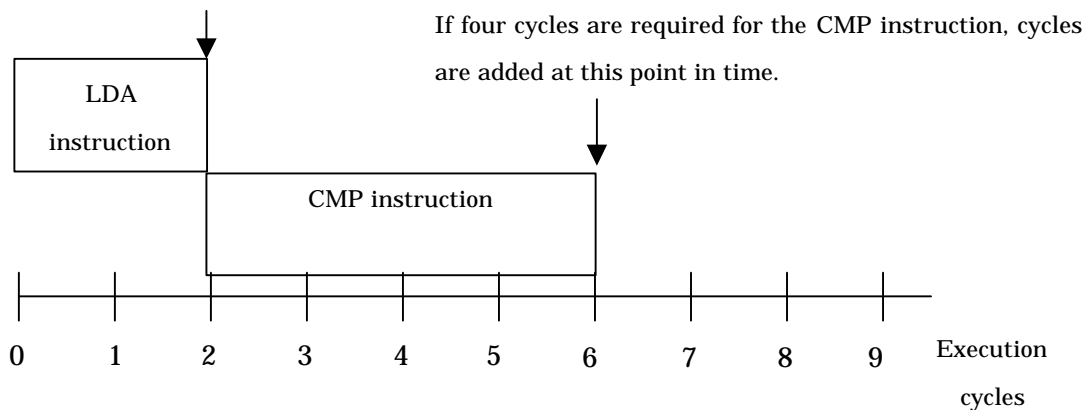

Figure 3.1 Method for measuring cycles

In the above example, no cycles are added while the LDA or CMP instruction is being executed. The cycles required for each instruction are added after instruction execution. Note that the virtual port input/output and virtual interrupt functions are processed after instruction execution is completed.

3.1.2 Peripheral I/O

No peripheral I/Os such as timers and serial I/O in the actual chip are supported. Only the CPU core is supported. Consequently, PD38SIM handles the SFR area to which peripheral I/Os are connected simply as RAM.

However, the CPU Mode Register's stack page select bit and the Interrupt Control Register each are handled as SFR. (For details about each register location, refer to the user's manual of your chip.)

When the stack page select bit is set to 1, one page of RAM can be used as a stack area.

When a bit of the Interrupt Control Register is set to 1, the corresponding interrupt of that bit is enabled.

Moreover, a method is provided that allows you to accomplish interrupts, e.g., a timer interrupt, and data input to SRF or other memory by simulating these operations without having to actually execute them. For details about this method, refer to the virtual port input/output and virtual interrupt functions described later in this manual.

3.1.3 Memory Space

Processor mode is not supported. The entire 64 KB of memory space from 0000₁₆ to FFFF₁₆ is allocated as RAM.

3.1.4 Interrupts

In the actual MCU, peripheral I/O (including external interrupt signals) are generating factors for interrupts. However, PD38SIM has nothing corresponding to peripheral I/O.

PD38SIM provides another method in place of this, which allows you to generate interrupts in a simulated manner (virtual interrupt function). Virtual interrupts can be generated at any time, e.g., in a specified cycle or at an executed address.

3.2 Operation of Instructions

3.2.1 WAIT

Executed as an NOP instruction.

Other instructions operate the same as those of the actual MCU.

3.3 Resetting

Resetting is performed in the same way as the actual MCU.

A reset is also performed when PD38SIM starts. The value 0000₁₆ is set in the reset vector (FFFC₁₆ to FFFD₁₆) immediately after starting. The program counter is therefore set to 0000₁₆ immediately after PD38SIM starts.

3.4 Memory

3.4.1 Types of Memory

The entire memory space (0000₁₆ to FFFF₁₆) functions as RAM. At startup, memory is allocated for the entire area.

3.4.2 Memory Structure and Initial Values Immediately after Starting

The memory is set up as follows immediately after starting PD38SIM.

0000₁₆ to FFFF₁₆

Filled with 00₁₆

3.5 Virtual Port Input Function

This function defines changes of the data that is input from external devices to a specified memory address. Using this function you can simulate data inputs to the ports defined in SFR.

The following shows timings at which data can be input to memory:

1. When program execution has reached a specified number of cycles
2. When a specified memory location is accessed for read by a program
3. When a specified virtual interrupt is generated

The input data at the above timings can be defined from the I/O Window. Furthermore, this function can be used in combination with the I/O script function, a function that allows you to define virtual port inputs and virtual interrupts. (For details, refer to "High-end Debugging" described later in this manual.) Using this I/O script function, you can specify more precise data input timings such as when the program fetches an instruction, when the program writes to memory, or when the program has executed instructions a specified number of times.

3.6 Virtual Port Output Function

When a data write to some memory address by the program occurs, this function records the written data value and the cycle at which the data was written.

The recorded data can be verified in graphic or numeric format from the I/O Window. The maximum number of data that can be recorded by this function is 30,000 entries counted from the beginning of program execution.

3.7 Virtual Interrupt Function

This function defines interrupt generation. Using this function you can generate timer interrupts and key input interrupts in a simulated manner without having to actually generate them.

The following shows timings at which virtual interrupts can be generated:

1. When program execution has reached a specified number of cycles
2. When the program has executed a specified address

Virtual interrupts at the above timings can be defined from the I/O Window. Furthermore, this function can be used in combination with the I/O script function, a function that allows you to define virtual port inputs and virtual interrupts. (For details, refer to "High-end Debugging" described later in this manual.) Using this I/O script function, you can specify more precise interrupt generation timings such as when the program reads or writes to memory or when the program has executed instructions a specified number of times.

3.7.1 Differences between Virtual Interrupts and Interrupts in Actual Chip

Virtual interrupts differ from interrupts in the actual chip in the following points:

1. About the Interrupt Control and Interrupt Request Registers
When a virtual interrupt is generated, PD38SIM looks up the Interrupt Control Register's interrupt control bit as it simulates virtual interrupt generation. If a virtual interrupt occurs when interrupt generation is disabled, the interrupt request is saved inside the simulator so that a virtual interrupt is generated after interrupt generation is enabled. However, since the interrupt request bit is not simulated, the interrupt request bit is not set even when an interrupt request is saved. Nor can the virtual interrupts that have been saved be deleted by clearing the interrupt request bit.
(The virtual interrupts saved in the simulator are deleted when the device is reset.)
Note that you can use the I/O script function to write a statement to the effect that the interrupt request bit is set when an interrupt occurs.
2. Reset interrupts cannot be generated.

3.8 GUI Input Function

This function implements the user target system's simple key input panel (buttons) in a window. The key input panel is created in the GUI input window.

By pressing a button created in the GUI input window, you can accomplish virtual port inputs and virtual interrupts.

- Input data to a specified memory address (virtual port input)
- Generate a specified virtual interrupt
- Accomplish specified virtual interrupt and virtual port input simultaneously

3.9 GUI Output Function

This function implements the user target system's simple output panel in a window. The output panel is created in the GUI input window.

The following parts can be arranged on this output panel:

- Character string
User-specified character strings are displayed or erased when some value is written to a specified memory address or according to logic 1 or 0 in bits.
- LED
LEDs are lit when some value is written to a specified memory address or according to logic 1 or 0 in bits.

3.10 I/O Script Function

This function allows you to write virtual port input and virtual interrupt settings to a file in script form. Therefore, it provides a more flexible way to define virtual port inputs and virtual interrupts than can be set from the I/O Window. Specifically, this includes, for example, reading the divide-by-N ratios you've set in the timer register and generating a timer interrupt periodically.

For details about I/O scripts, refer to "High-end Debugging" described later in this manual.

3.11 Unique Simulator Functions

3.11.1 Stack Utilization Monitor: The StackMonitor (SM) Command

Use the StackMonitor command to check the maximum and minimum addresses of the stack, and to determine how much the program has used of what part of the stack.

The stack monitoring continues from the time that a Go or GoFree command is invoked until it is interrupted, the maximum and minimum values being recorded for the stack pointer (S register).

If, while the program is running, it causes a change in the value of a stack pointer, monitoring of stack utilization of that stack stops at that point.

3.11.2 Cycle Count Monitor Function: The CYcle (CY) Command

Use the CYcle command to determine the number of cycles in a program that has been run. The number of cycles is obtained using the values described in the "740 Software Manual". The number of cycles is counted when the program is run with the cycle count monitor mode ON. They are not monitored when the mode is OFF.

The results of monitoring the cycles are initialized when the cycle count monitor mode is set ON. If the cycle count monitor mode is left ON, the results are accumulated each time the program is run. To restart monitoring from the beginning, set the cycle count monitor mode ON again using the CYcle command (it is not necessary to turn the mode OFF beforehand).

4 PD38SIM Input and Output Files

4.1 Input Files

PD38SIM processes the following input files.

4.1.1 IEEE-695 Absolute Format Files

The IEEE-695 absolute format files contain debugging information such as data on the variables used in the source files as well as line data, and machine language data. These files, which are generated by the ICC740 C compiler made of the IAR company, take the attribute ".695".

4.1.2 Symbol Files

This file contains debug information such as symbol information and line number information. A SYM file can be generated by specifying the "-S" option when executing LINK74. The file attribute is .SYM. Although a SYM file is not necessarily required for PD38SIM to operate, most of its functions are unavailable to use without a SYM file read in. Therefore, always be sure to read in a SYM file along with a HEX file.

4.1.3 Intel HEX-format Files

This file contains the machine language generated by the LINK74 Linker for the SRA74 Assembler. The file attribute is .HEX. PD38SIM reads in a HEX file and loads the target program into the emulator.

4.1.4 Register Information File

The register information file, which is named "PD38SIM.rdf", contains information of MCU registers (register name and size, etc.).

PD38SIM automatically reads this file and uses the information to display the register window (The register window does not open if this file does not exist).

This file is supplied with PD38SIM. The user cannot edit it.

4.1.5 Script File

The script file is for automatic execution of script commands. This file, which is read from the Script Window, takes the attribute ".scr".

4.1.6 Help File

The help file contains help messages for PD38SIM. This file, which is supplied with PD38SIM, takes the attribute ".hlp".

4.1.7 Environmental Setup File

The environmental setup file, which is automatically generated by PD38SIM and cannot be directly created or edited by the user, stores information about the environmental setup of PD38SIM. The filename is pd38sim.ini. The environmental setup file is saved to the Windows directory (the directory in which you have installed Windows).

4.1.8 SFR File

This file contains the information inherent to the target MCU. The SFR file is included with product. The file name is M3xxxx.SFR.

4.1.9 Coverage File

This is a binary file that contains the results of coverage measurements. The file attribute is ".cov." This file can be saved and loaded from and into the coverage window.

4.1.10 ASM Watch Point Data File

The ASM watch point data file contains data on the ASM watch point that is input from the ASM Watch window. The file extension is ".wpt" and the file itself can be read from the ASM Watch window.

4.1.11 C Watch point Data File

The C watch point data file, which is created automatically by PD38SIM, stores information on the C watch points recorded in the C Watch Window. The file attribute is ".cwp". This file is stored in the Windows directory (the directory in which you installed Windows). It cannot be created or edited by the user.

4.1.12 Software Breakpoint File

The software breakpoint file, which takes the suffix ".brk", contains the software breakpoint settings.

You can read in this file via the S/W Breakpoint dialog box to set the software breakpoints.

4.1.13 I/O Script File

This file contains a description of virtual port inputs and virtual interrupts. The created I/O script file is read from the I/O Window. The file attribute is ".scr."

4.1.14 GUI Input File

This file contains definitions of the key panel created in the GUI input window that have been saved to a file. The file attribute is ".btn."

By reading this file from the GUI input window, you can set up the panel key you've created newly again.

4.1.15 GUI Output File

This file contains definitions of the output panel created in the GUI output window that have been saved to a file. The file attribute is ".gof."

By reading this file from the GUI output window, you can set up the output panel you've created newly again.

4.2 Output Files

PD38SIM outputs the following files.

4.2.1 Intel HEX-format Files

The Intel HEX-format files store machine language data. These files, which are saved using PD38SIM's upload function, take the attribute ".hex". Files saved in the Intel HEX format can be downloaded by PD38SIM.

4.2.2 Disassemble Files

Disassemble files store the results of disassembling program memory. These files, which are reference text files, take the attribute ".txt". Disassemble files cannot be reassembled or downloaded.

4.2.3 Log File

The log file is a text file containing the results of executing the script commands. This file, which takes the attribute ".log", contains the results from the logon point to the logoff point.

4.2.4 View File

The view file is a text file that contains the contents of the script window. In PD38SIM, the last 1000 lines of the results of executing the script commands are stored in the view buffer. The view file, which takes the attribute ".viw", contains the contents of the view buffer.

4.2.5 Coverage File

This is a binary file that contains the results of coverage measurements. The file attribute is ".cov." This file can be saved and loaded from and into the coverage window.

4.2.6 ASM Watch Point Data File

The ASM watch point data file contains data on the ASM watch point that is input from the ASM Watch window. The file extension is ".wpt" and the file itself can be read from the ASM Watch window.

4.2.7 Software Breakpoint File

The software breakpoint file, which takes the suffix ".brk", contains the software breakpoint settings.

You can save this file via the S/W Breakpoint dialog box to set the software breakpoints.

4.2.8 I/O Script File

This file contains definitions of virtual port inputs and virtual interrupts set or created in the I/O Window that have been saved to a file.

4.2.9 GUI Input File

This file contains definitions of the key panel created in the GUI input window that have been saved to a file. The file attribute is ".btn."
This file is saved from the GUI input window.

4.2.10 GUI Output File

This file contains definitions of the output panel created in the GUI output window that have been saved to a file. The file attribute is ".gof."
This file is saved from the GUI output window.

4.2.11 Virtual Port Output File

This file contains the results of virtual port outputs specified in the I/O Window that have been saved to a file.
This file is referenced by PD38SIM when it displays the results of virtual port outputs in the I/O Window.

4.3 Temporary Files

4.3.1 Files Created When Using On-Demand Method

A temporary file is created when you specify on-demand reading of debugging information when downloading a target program. Temporary files are created with the filename pdb_xxxx.tmp (where xxxx is a 4-digit hexadecimal value) in the directory containing the downloaded files. Temporary files are deleted immediately prior to downloading and when you quit PD38SIM.

4.3.2 Files Created in I/O Window

Temporary files are created when you set virtual port inputs or virtual interrupts or I/O script files in the I/O Window. PD38SIM creates these temporary files in the directory in the files that contain virtual port input or virtual interrupt settings are stored or the directory in which the I/O script files are stored. Therefore, unless these directories are permitted for access, an error may occur when an attempt is made to read files from the directory using the I/O Window menus [Option] - [Load].

[MEMO]

Setup

1. Setup

1.1. Installation

See the Release Notes provided with the product for how to install PD38SIM.

1.2. Starting PD38SIM

Follow the instructions below to start PD38SIM:

Click the start button, then select

program (P)-> [RENESAS - TOOLS] -> [PD38SIM V.X.XX Release X] -> [PD38SIM]



This operation starts pd38sim(the simulator debugger front end), and simultaneously starts sim38 (the simulator engine). If sim38 is already running, only pd38sim starts.

1.3. PD38SIM Setup

When you start PD38SIM, the Init dialog box is displayed, allowing you to set up the operating environment.

1.3.1. Init Dialog Box Screen Configuration

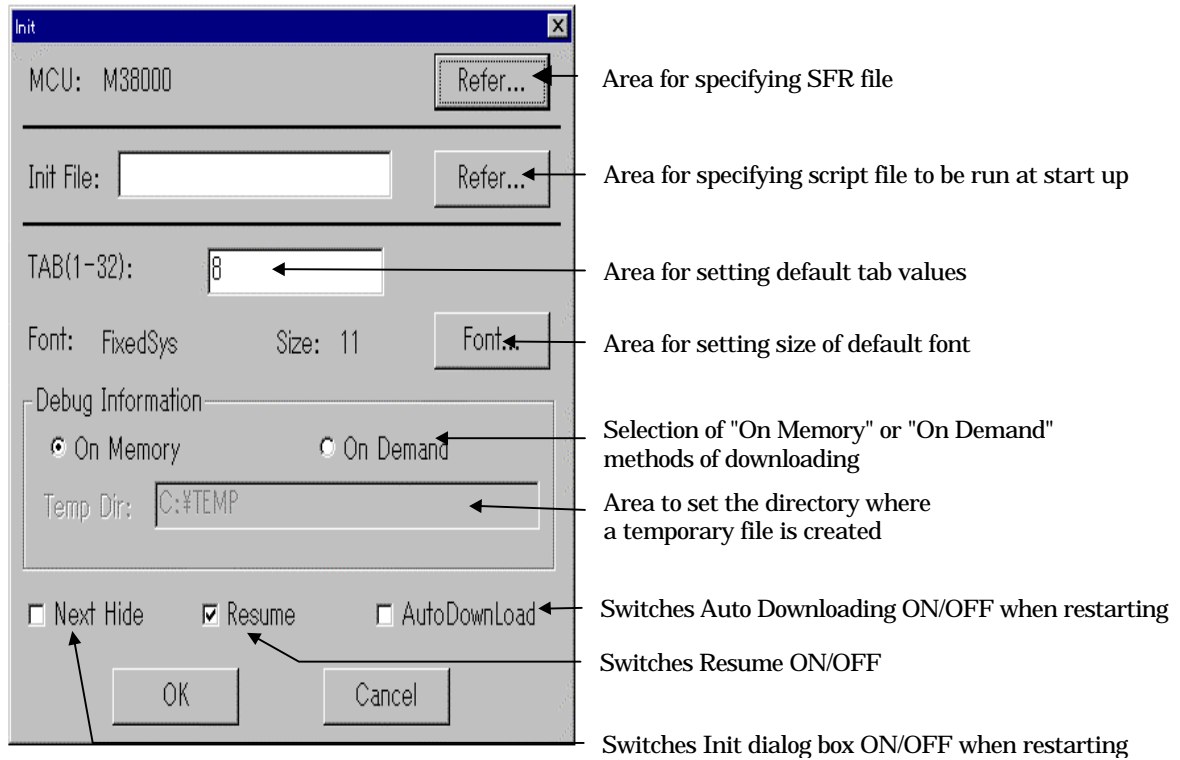

1.3.2. Environment Setup

Specifying the SFR file

Specify the SFR file for the target MCU. Click the "Refer" button to open the file selection dialog box and select the SFR file. When the corresponding SFR file does not exist, it is necessary to make the SFR file newly. Please refer to item "Method of making the SFR file" of the release note appended to this product package for the method of making the SFR file.

Specifying the script file to be executed at startup

Specify a script file if you want to execute script commands at startup. These commands must have been saved as a script file. Click the "Refer" button to open the file selection dialog box, then use the mouse to select the script file to be executed at startup. The selected script file is displayed after InitFile: in the Init dialog box.

Setting of default TAB values

Specify the default tab values for the Program Window, Source Window. You can specify TAB values between 1 and 32.

Note:

You can set the tabs independently in each window. With the target window active, select [Option] -> [TAB] from the menu in the PD38SIM Window to open the TAB Setting dialog box. You can now set the tabs for the active window.

Setting of default font size

Specify the default font for the characters displayed by PD38SIM. Click the "Font" button to open the Font dialog box, then specify the font and the font size.

Note:

You can set the font size independently in each window. With the target window active, select [Option] -> [Font] from the menu in the PD38SIM Window to open the Font Setting dialog box. You can now set the font size for the active window.

Selection of "On Memory" or "On Demand" method of downloading

This selection determines whether the debugging information is fetched using the "On Memory" or "On Demand" method when a target program has been downloaded. When you select "On Memory", all the debugging information is stored in memory. When you select "On Demand", a temporary file is created when you download the target program, and the required debugging information is read from that file into memory as it is required.

When you select [Environ] -> [Init] from the PD38SIM and select "On Memory" or "On Demand" from the Init dialog box, the specified method is valid from the next time you download a target program.

Specifying temporary directory in on-demand mode

PD38SIM creates a temporary file when the target program has been downloaded using the on-demand method. This temporary file is created in a specified directory. If no directory is specified, the temporary file is created in the directory where the downloaded file exists.

Switches of Init dialog box ON/OFF of restarting

Specify whether the Init dialog box should be opened when restarting PD38SIM. Check "Next Hide" to stop the Init dialog box being opened when you next start PD38SIM. If you want to display the Init dialog box when you next start PD38SIM, select [Init] -> [Environ] from the PD38SIM Window menu, then uncheck "Next Hide" in the Init dialog box. You can also force the Init dialog box to be displayed when you start up by pressing and holding the Ctrl key when starting PD38SIM.

Switches of Resume ON/OFF

You can specify whether, when you restart PD38SIM, the windows are restored to their status when you last quit the program. Check the Resume box to do so.

Selection of Auto downloading at startup

You can specify whether, when you restart PD38SIM, the program automatically fetches the last-read target program. Check the Auto Download box to do so.

1.4. sim38 Setup

When **sim38** starts up, it is registered in the system tray.

1.4.1.sim38 When Running



Right-clicking on the running **sim38** and selecting [Version...] from the menu bar will open up the Version Information dialog box.

1.4.2. Structure of Version Information Dialog Box

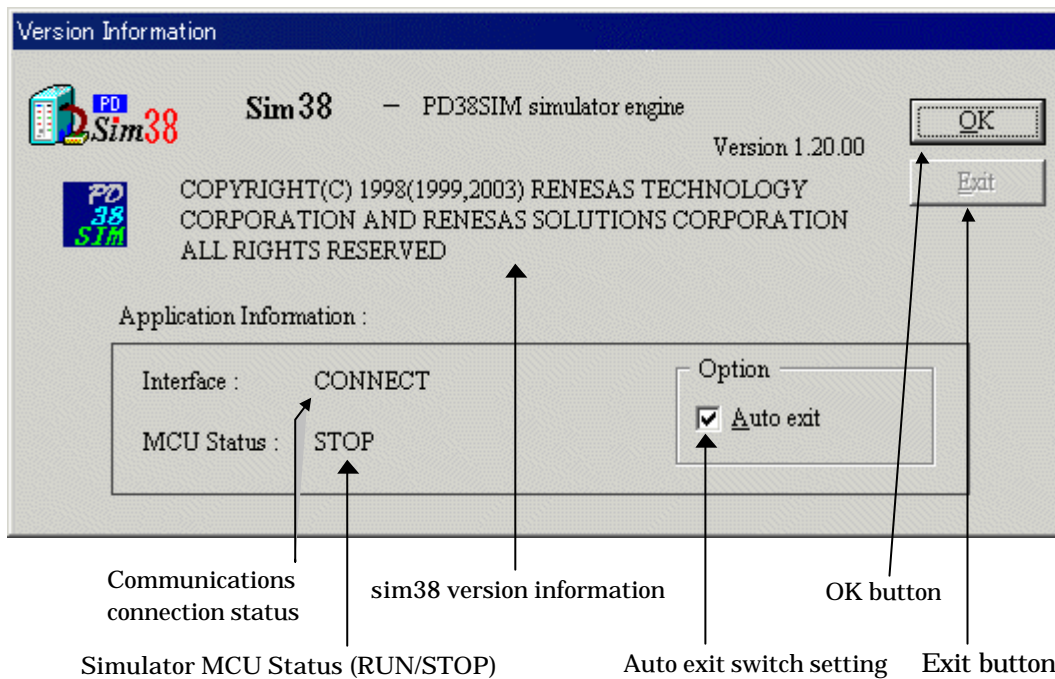

1.4.3. Setting Up

Auto Exit Switch Setting

Check the Auto exit checkbox to automatically exit sim38 when you exit pd38sim.

Communications Connection Status

CONNECT is displayed when connected to pd38sim. CUT is displayed when there is no connection.

Simulator MCU Status (RUN/STOP)

RUN is displayed when the simulator MCU is running, STOP when stopped.

OK button

Closes the Version Information dialog box

Exit button

Exits sim38. Note that you cannot exit sim38 while connected to pd38sim.

Window function

1 Window function of PD38SIM

1.1 The PD38SIM Window

The PD38SIM Window is the main window for PD38SIM. This window displays the main commands on a toolbar. You can click on the buttons on this toolbar to run the target program in normal or one-step mode. The main display area accommodates windows such as the Target Program Window.

1.1.1 PD38SIM Window Screen Configuration

Annotations in the image:

- Menu for executing commands
- Toolbar with main command buttons
- Main display area
- Sub windows
- Displays help on how to use windows and menus
- Displays status of execution of target program

RAM Monitor Window Data:

Address	0	1	2	3	4	5	6	7	8	9	A	B	C	D	E	F	ASCII
00D0	00	00	00	00	00	00	00	00	00	00	00	00	00	00	00	00
00E0	00	00	00	00	00	00	00	00	00	00	00	00	00	00	00	00
00F0	00	00	00	00	00	00	00	00	00	00	00	00	00	00	00	00
0100	D6	02	00	00	00	00	00	00	00	00	00	00	00	00	00	00
0110	00	00	00	02	01	00	00	00	00	00	00	00	00	00	00	00
0120	00	00	00	00	00	00	00	00	00	00	00	00	00	00	00	00
0130	00	00	00	00	00	00	00	00	00	00	00	00	00	00	00	00
0140	00	00	00	00	00	00	00	00	00	00	00	00	00	00	00	00
0150	00	00	00	00	00	00	00	00	00	00	00	00	00	00	00	00
0160	00	00	00	00	00	00	00	00	00	00	00	00	00	00	00	00

1.1.2 PD38SIM Window Toolbar

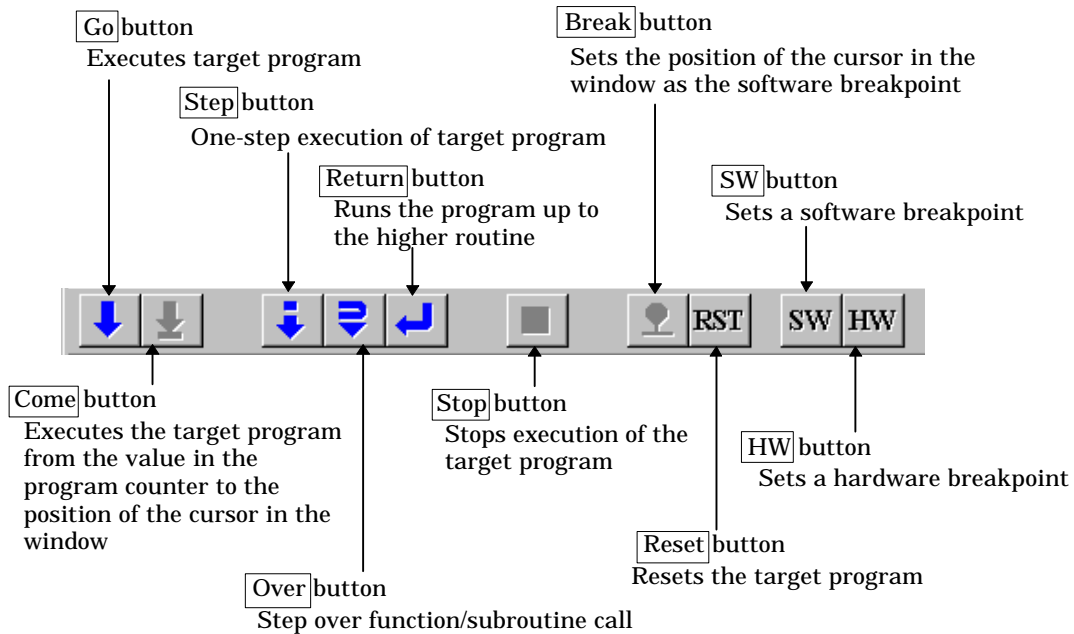

1.1.3 PD38SIM Window Menu

The menus in the PD38SIM Window can be classified as basic menus and extended menus.

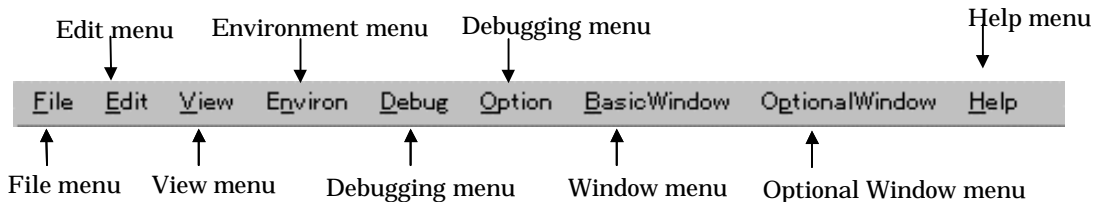

Basic Menus and Extended Menus

The sub-menu items of the optional menu in PD38SIM automatically change according to which window is active in the main display area of the PD38SIM window. The optional menus are called extension menus.

In contrast, the items on all menus other than the optional menu remain the same no matter which window is active. These are called basic menus, and provide the items for the basic operation of PD38SIM and debugging.

Below, we look at the functions of each item on the basic menus. The functions of the items on the extended menus are described under the respective windows.

1.1.3.1 File operation

The [File] menu in PD38SIM contains the items required for file operation such as including files, saving files, and terminating PD38SIM.

Menu	Menu options	Function	Shortcut keys
File	Download	Download target program.	–
	Load Module...	Download machine language data and debugging information.	Shift + F.1
	Memory Image...	Download only machine language data.	–
	Symbol...	Download only debugging information.	–
	Reload	Reload target program.	–
	Upload...	Upload target program.	–
	AutoDownload...	Automatically download when the target program is updated.	–
	Save Disasm...	Save disassembly result.	–
File Name	List the file name of target program downloaded.	–	
Exit	Terminate PD38SIM.	–	

1.1.3.2 Editing

The [Edit] menu in PD38SIM contains the items required for editing operation such as character strings copy, paste, and search.

Menu	Menu options	Function	Shortcut keys
Edit	Copy	Copy character strings specified to clipboard.	Ctrl + C
	Paste	Paste character strings of clipboard.	Ctrl + V
	Find...	Find character strings.	–

1.1.3.3 Display

The [View] menu in PD38SIM contains the items required for switching display of the tool bar and status bar.

Menu	Menu options	Function	Shortcut keys
View	Tool Bar	Switch display or non-display of tool bar.	–
	Status Bar	Switch display or non-display of status bar.	–

1.1.3.4 Setup

The [Environ] menu in PD38SIM contains the items required for setting up the operating environment.

Menu	Menu options	Function	Shortcut keys
Environ	Init...	Environment setup	–
	Path...	Source file search path	–
	Start Up...	Startup function settings	–
	Customize...	Open Customize dialog box.	–

1.1.3.5 Debugging (Basic)

The [Debug] menu in PD38SIM contains the items for basic debugging such as starting and stopping and one-step execution of the target program.

Menu	Menu options	Function	Shortcut keys
Debug	Go	Start target program.	–
	Go	Run from current program counter.	F.1
	Go Option...	Run from specified address.	–
	GoFree	Free-run target program.	–
	Come	Run to cursor position.	F.2
	Step	Step execution.	–
	Step	Execute one step.	F.3
	Step Option...	Execute specified No. of steps.	–
	Over	Over-step execution.	–
	Over	Execute one over-step.	F.4
	Over Option...	Execute specified No. of over-steps.	–
	Return	Execute until return from current subroutine.	F.5
	Break Point	Set break point.	–
	S/W Break Point...	Open S/W Break Point Setting dialog box.	F.7
	H/W Break Point...	Open H/W Break Point Setting dialog box.	Shift + F.7
	Break	Set/cancel software break at cursor.	–
Reset	Reset target program.	F.8	
Stop	Stop target program.	–	
Scope...	Open Scope Setting dialog box	–	
Entry...	Entry makefile	–	
Make	Make target program	–	

1.1.3.6 Debugging (Option)

The extended menus in PD38SIM contains the items for operating the various PD38SIM windows. The items on the extended menu differ according to which window is active. The functions of the items on the extended menus are described under the respective windows.

Menu	Menu options	Function	Shortcut keys
Option		(This menu contains the extended menus for the various PD38SIM windows.)	–

1.1.3.7 Window Operations

The [BasicWindow] menu has assigned to it the menus which among PD38SIM functions, are used to control the display mode of each window provided by PD38SIM and to open the basic windows of PD38SIM.

Menu	Menu options	Function	Shortcut keys
BasicWindow	Cascade	Cascade windows.	–
	Tile	Tile windows.	–
	Arrange Icon	Arrange icons.	–
	Program Window	Make Program Window active.	–
	Source Window	Open Source Window.	–
	Register Window	Open Register Window.	–
	Memory Window	Open Memory Window.	–
	Dump Window	Open Dump Window.	–
	RAM Monitor Window	Open RAM Monitor Window.	–
	ASM Watch Window	Open ASM Watch Window.	–
	C Watch Window	Open C (language-level) Watch Window.	–
	C Watch Window	Open C Watch Window.	–
	Local Window	Open Local Window.	–
File Local Window	Open File Local Window.	–	
Global Window	Open Global Window.	–	
Script Window	Open Script Window.	–	

The [OptionalWindow] menu has assigned to it the menus which among PD38SIM functions, are used to open windows of greater functionality.

Menu	Menu options	Function	Shortcut keys
OptionalWindow	IO Window	Open IO Window.	–
	GUI Input Window	Open GUI input Window.	–
	GUI Output Window	Open GUI Output Window.	–
	Coverage Window	Open Coverage Window.	–
	Custom Window		–
	Option	Entry Custom Window	–
	User definition menu	Open the custom window	–

1.1.3.8 Help

The [Help] menu contains the items for displaying PD38SIM help messages and the PD38SIM version No.

Menu	Menu options	Function	Shortcut keys
Help	Index	Display help.	–
	About...	Display version information about PD38SIM.	–

1.2 Program Window

The Program Window displays the machine code at the current program counter. The line at the program counter is highlighted in yellow. The Program Window is automatically opened in the main display area of the PD38SIM Window when you start PD38SIM. The Program Window can be used for executing the target program up to the cursor position, set or cancel software breakpoints using the mouse, and displaying reverse assembles of the target program, etc. Double-click the software breakpoint display/setting area to set or cancel software breakpoints.

By choosing menus [Option] → [Line Assemble] after clicking on a program display area, you can perform line assemble beginning with the position you have clicked.

1.2.1 Structure of Program Window

The Program Window has three display modes: source, disassemble, and mixes source with disassemble. The structure of the Program Window is described for each display mode below.

1.2.1.1 Structure of Program Window in Source Display Mode

The source display mode is provided for debugging at the source level. You can check the source files of the target program in source display mode.

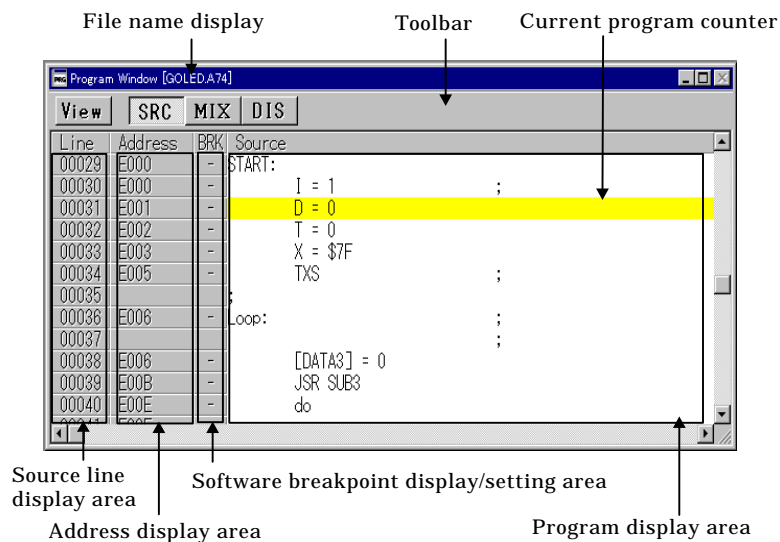

- The line No. display area and address display area can be displayed or hidden by selecting or canceling [Option] → [Layout] → [Line Area] and [Option] → [Layout] → [Address Area]. Note that, by default, the address display area is hidden.
- Double-click the line No. display area to change the display source file.
- Double-click the address display area to change the display starting address or the display starting line.
- The value of the C variable is displayed, when the mouse cursor stand still (about 0.5 seconds) on the strings of the variable in the Program display.
- The result of the Coverage measurement is displayed by selecting [On] in the Menu [Option] → [Coverage].

1.2.1.2 Structure of Program Window in MIX Display Mode

In MIX display mode, the source program is displayed with the results of its disassembly. The source program is displayed in a different color from the results of disassembly.

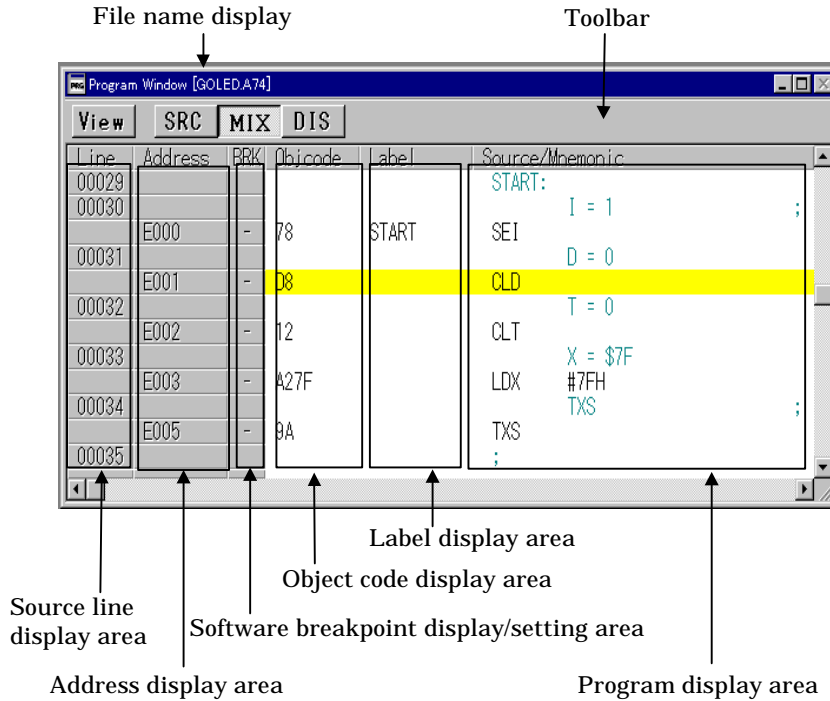

- The line No. display area, address display area, and object code display area can be displayed or hidden by selecting or canceling [Option] -> [Layout] -> [Line Area], [Option] -> [Layout] -> [Address Area], and [Option] -> [Layout] -> [Code Area]. Note that, by default, the address display area is hidden.
- Double-click the line No. display area to change the display source file.
- Double-click the address display area to change the display starting address or the display starting line.
- The result of the Coverage measurement is displayed by selecting [On] in the Menu [Option] -> [Coverage].

1.2.1.3 Structure of Program Window in Disassemble Display Mode

The disassemble display mode is provided for debugging at the instruction level. You can check the results of disassembling the target program in disassemble display mode.

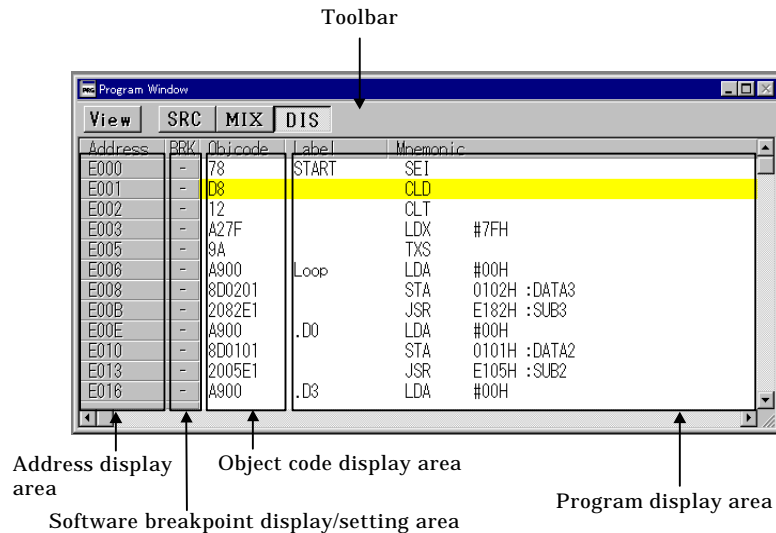

- The address display area and object code display area can be displayed or hidden by selecting or canceling [Option] → [Layout] → [Address Area] and [Option] → [Layout] → [Code Area].
- Note that you cannot scroll backwards vertically until you have scrolled forwards. When you scroll forwards, the previous display address is stored in the internal buffer. This address information is used when you scroll backwards.
Note that the internal buffer is cleared if you execute a command that changes the first line address.
- If you disassemble an area (data or empty area, etc.) other than the program, the contents of memory are interpreted as instruction code and displayed in disassembled format. In this case, "???" is displayed for undefined instructions and operands.
- Double-click the address display area to change the display starting address.
- The result of the Coverage measurement is displayed by selecting [On] in the Menu [Option] → [Coverage].

1.2.2 Shortcut Menus of the Program Window

When you click the right mouse button in the Program Window, the shortcut menu opens. And you can display the source file that contains the selected function, or you can register the selected variable as C watch point.

Menu	Menu options	Function	Shortcut keys
Right Clicking	Jump to function	Display the selected function	–
	Open Source Window	Open Source Window Display the selected function (opening the new Source Window)	–
	Add C Watch...	Register the C watch point of the selected variable	–
	Add C Watch Pointer...	Register the C watch point of the selected variable's pointer.	–
	Add ASM Watch...	Register the ASM watch point of the selected symbol.	–
	BitAdd ASM Watch...	Register the ASM watch point of the selected bit symbol.	–
	Open Editor	Open the source file by the editor.	–
	Entry Editor...	Register the editor to open the source files.	–
Line Assemble...	Open the Line Assemble Dialog Box.	–	

1.2.3 Program Window Toolbar

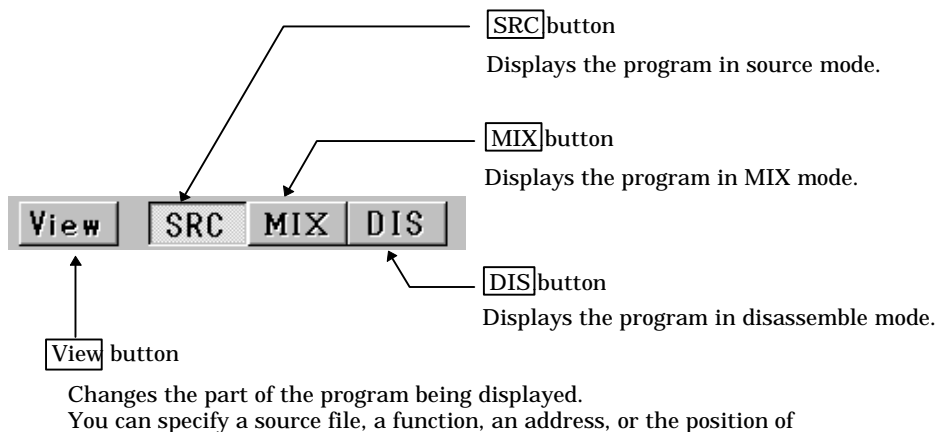

1.2.4 Extended menu in the Program Window

When the Program Window is active in the PD38SIM main display area, the [Option] menu contains the following items:

Menu	Menu options	Function	Shortcut keys
Option	Font...	Change font.	–
	TAB...	Set source file display tabs.	–
	Color...	Change display color	–
	View	Change contents of display.	–
	Source...	Display from specified source file or function.	–
	Address...	Display from specified address or line No.	–
	Program Counter	Display from current program counter.	–
	Mode	Switch display mode.	–
	Source mode	Switch to source display mode.	Ctrl + R
	Mix mode	Switch to MIX display mode.	Ctrl + R
	Disasm mode	Switch to disassemble display mode.	Ctrl + R
	Layout	Set layout.	–
	Line Area	Turn on/off line No. area.	–
	Address Area	Turn on/off address area.	–
	Code Area	Turn on/off object code area.	–
	Line Assemble...	Open Line Assemble dialog	Ctrl + L
	Coverage	Set Coverage measurement.	–
	On/Off	Turn on/off Measurement result.	–
	Clear	Initialize coverage measurement result	–
	Refresh	Update display of coverage measurement result	–

1.3 Source Window

The Source Window is provided for dedicated display of the program being checked. The line at the program counter is highlighted in yellow. In contrast to the Program Window, which follows the program counter, the Source Window is not updated until you specify. Use the Source Window to check what is happening in specific subroutines and tasks. You can open up to 10 Source Windows. Other functions are the same as in the Program Window.

1.3.1 Structure of Source Window

The Source Window has three display modes: source, disassemble, and mixes source with disassemble. The structure of the Source Window is described for each display mode below.

The Source Window has the same structure as the Program Window. See Section 1.2.1, "Structure of Program Window" under Window Functions for details.

1.3.1.1 Structure of Source Window in Source Display Mode

The source display mode is provided for debugging at the source level. You can check the source files of the target program in source display mode.

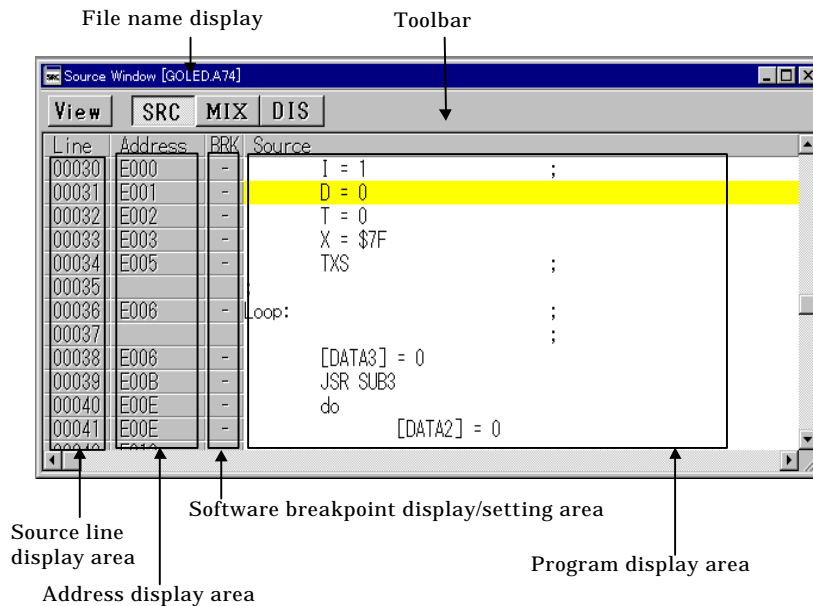

1.3.1.2 Structure of Source Window in MIX Display Mode

In MIX display mode, the source program is displayed with the results of its disassembly. The source program is displayed in a different color from the results of disassembly.

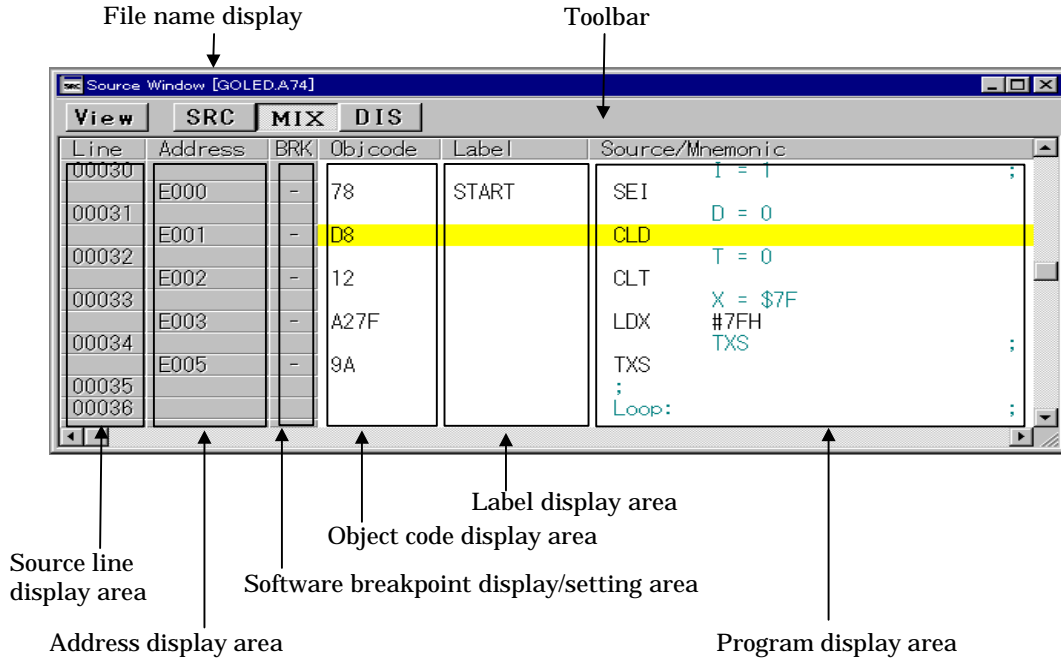

1.3.1.3 Structure of Source Window in Disassemble Display Mode

The disassemble display mode is provided for debugging at the instruction level. You can check the results of disassembling the target program in disassemble display mode.

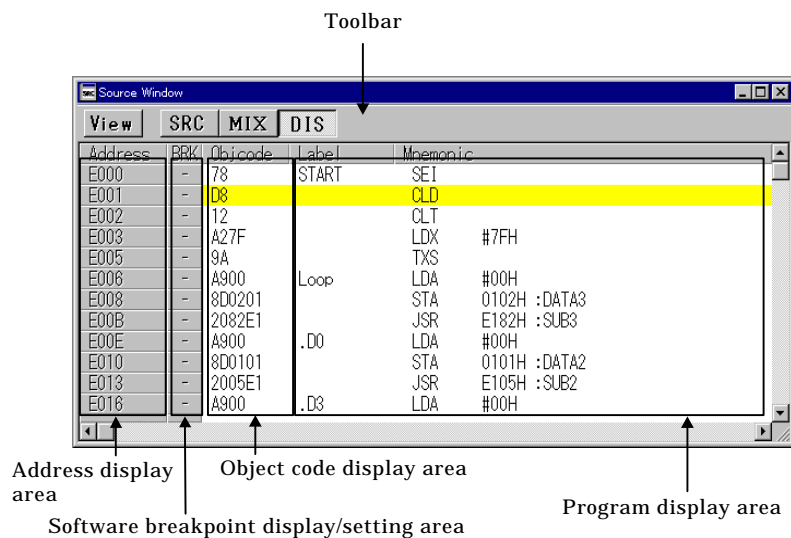

1.3.2 Shortcut menus in the Source Window

The Source Window shortcut menus is similar to that of the Program Window. See Section 1.2.2, "Shortcut Menus of the Program Window" under Window Functions for details.

1.3.3 Source Window Toolbar

The Source Window toolbar is the same as that in the Program Window. See Section 1.2.3, "Program Window Toolbar" under Window Functions for details.

1.3.4 Extended Menus in the Source Window

When the Source Window is active in the PD38SIM main display area, extended menus for the Source Window are allocated to the [Option] menus. The extended menus of the Source Window are identical to those of the Program Window. See Section 1.2.4, "Extended menu in the Program Window" under Window Functions for details.

1.4 Register Window

The Register Window shows the contents of the registers and flags. The display is updated after each command is executed. You can click the buttons corresponding to registers in the Register Window to quickly change the values of the registers and flags.

1.4.1 Structure of Register Window

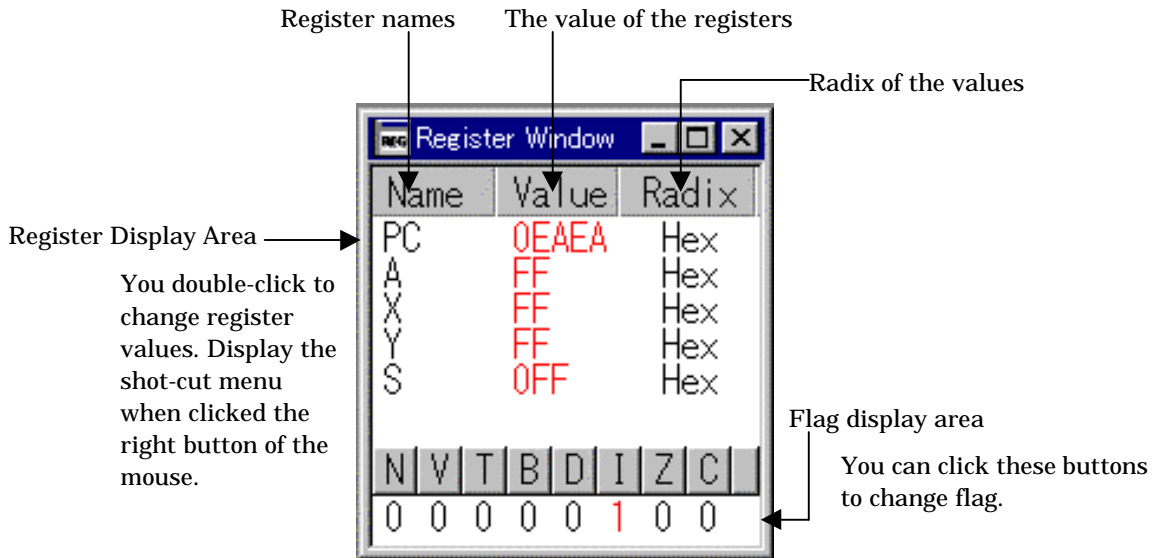

1.4.2 Extended Menu in the Register Window

When the Register Window is active in the PD38SIM main display area, the [Option] menu contains the following items:

Menu	Menu options	Function	Shortcut keys
Option	Layout	Set layout	-
	Hide Radix	Turn on/off radix.	-
	Hide ELAGs	Turn on/off flags.	-
	Font...	Change font.	-

1.4.3 Shortcut Menu in the Register Window

Press the right button of the mouse on the register display area in Register Window to display shortcut menu.

Menu	Menu options	Function	Shortcut keys
Right click	Hex	Display in hexadecimal.	–
	Dec	Display in decimal.	–
	Bin	Display in binary.	–
	Layout	Set layout.	–
	Hide Radix	Turn on/off radix.	–
	Hide ELAGs	Turn on/off flags display area.	–
Font...	Change font.	–	

- The value changed is displayed in red.

1.5 Memory Window

The Memory Window displays the contents of contiguous memory in "address", "label", and "data (contents of memory)" formats. The display is updated after each command is executed. Data can be displayed in binary, decimal, hexadecimal, and ASCII. You can open up to 10 Memory Windows. You can use the Memory Windows to modify the contents of memory, and also to fill and move specified blocks of memory.

1.5.1 Structure of Memory Window

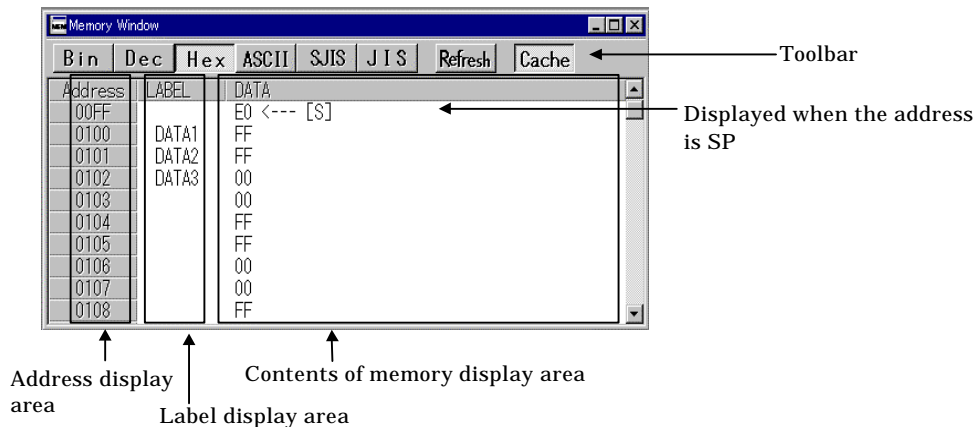

- Double-click the address display area to change the display starting address.
- Double-click a label or the memory display area to change the contents of memory.
- The start and end address in the FILL and MOVE Dialog Box can be specified by selecting data in the data display area.

After the selecting, when selecting the menu [Option] -> [Debug] -> [Move] or [Option] -> [Debug] -> [Fill], the start and end address of selected area are set in the MOVE or FILL Dialog Box.

1.5.2 Memory Window Toolbar

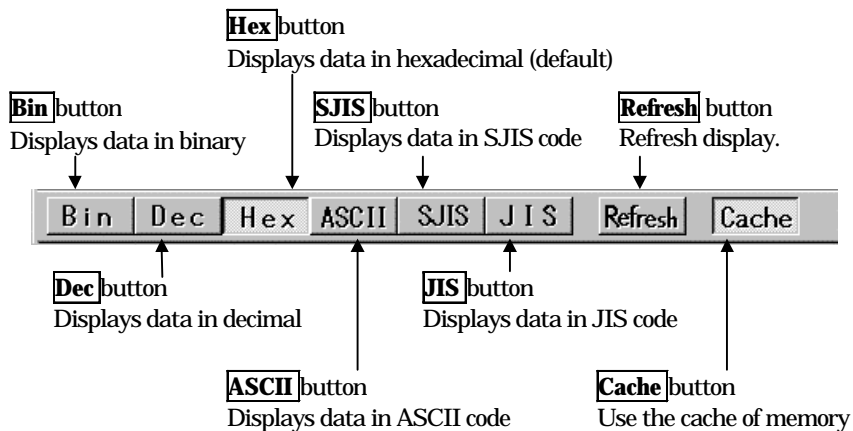

1.5.3 Extended Menus in the Memory Window

When the Memory Window is active in the PD38SIM main display area, the [Option] menu contains the following items:

Menu	Menu options	Function	Shortcut keys
Option	Font..	Change font.	–
	View	Change contents of display.	–
	Scroll Area..	Specify scroll range.	–
	Address..	Specify display starting address.	–
	S	Change display starting address to value of Stack Pointer.	–
	Data Length	Specify data length.	–
	Byte	Display in 1-byte units.	–
	Word	Display in 2-byte units.	–
	Radix	Specify radix.	–
	Bin	Display in binary.	–
	Dec	Display in decimal.	–
	Hex	Display in hexadecimal.	–
	Ascii	Display as ASCII characters.	–
	SJIS	Display as SJIS characters.	–
	JIS	Display as JIS characters.	–
	Refresh	Refresh display.	–
	Debug	Set memory contents.	–
	Set..	Set data at specified address.	–
	Fill..	Fill specified memory block with data.	–
	Move..	Move specified memory block to specified address.	–
Cache On	Use the cache of memory	–	

1.6 Dump Window

The Dump Window displays the contents of contiguous memory in dump format. The display is updated after each command is executed. You can open up to 10 Dump Windows. You can use the Dump Windows to modify the contents of memory, and also to fill and move specified blocks of memory.

1.6.1 Structure of Dump Window

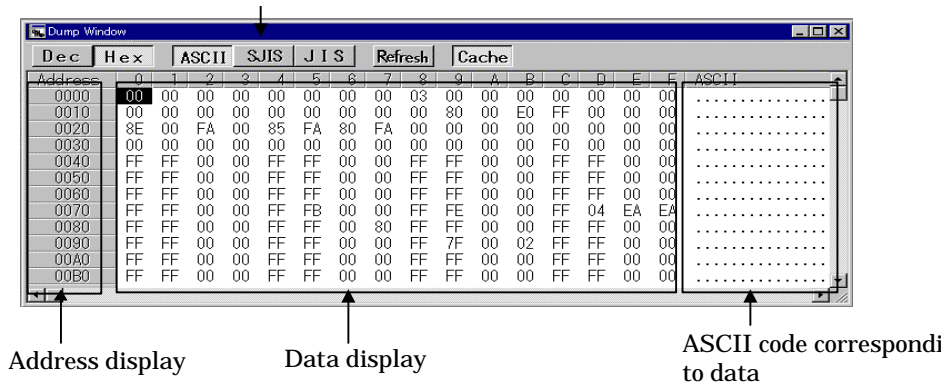

- Double-click the address display area to change the display starting address.
- Double-click a label or the memory display area to change the contents of memory.
- The start and end address in the FILL and MOVE Dialog Box can be specified by selecting data in the data display area.

After the selecting, when selecting the menu [Option] -> [Debug] -> [Move] or [Option] -> [Debug] -> [Fill], the start and end address of selected area are set in the MOVE or FILL Dialog Box.

1.6.2 Dump Window Toolbar

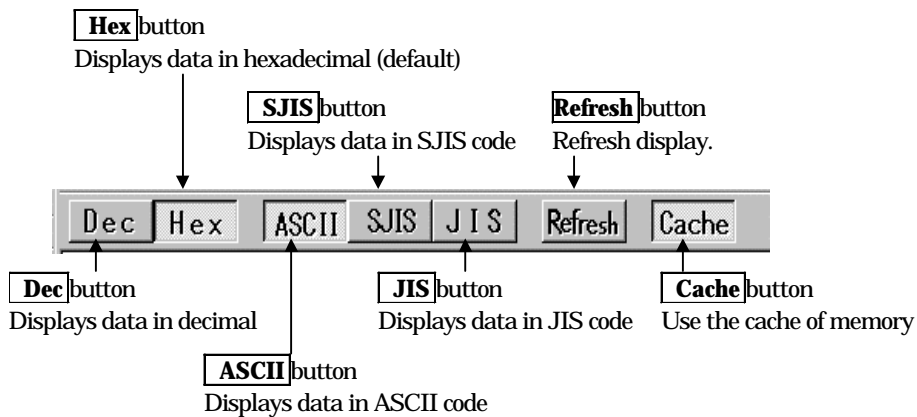

1.6.3 Extended Menus in the Dump Window

When the Dump Window is active in the PD38SIM main display area, the [Option] menu contains the following items:

Menu	Menu options	Function	Shortcut keys
Option	Font...	Change font.	–
	View	Change contents of display.	–
	Scroll Area...	Specify scroll range.	–
	Address...	Specify display starting address.	–
	Data Length	Specify data length.	–
	Byte	Display in 1-byte units.	–
	Word	Display in 2-byte units.	–
	Radix	Specify radix.	–
	Dec	Display in decimal.	–
	Hex	Display in hexadecimal.	–
	Ascii	Display as ASCII characters.	–
	SJIS	Display as SJIS characters.	–
	JIS	Display as JIS characters.	–
	Refresh	Refresh display.	–
	Debug	Set memory contents.	–
	Set...	Set data at specified address.	–
	Fill...	Fill specified memory block with data.	–
	Move...	Move specified memory block to specified address.	–
	Cache On	Use the cache of memory	–

1.7 RAM Monitor Window

The RAM Monitor Window displays the contents of memory in the RAM monitor area in dump format. The display is updated at constant intervals (default = 100ms) during execution of the target program. The PD38SIM have 1KB of RAM monitor memory area. You can set any contiguous address area as the RAM monitor area.

1.7.1 Structure of RAM Monitor Window

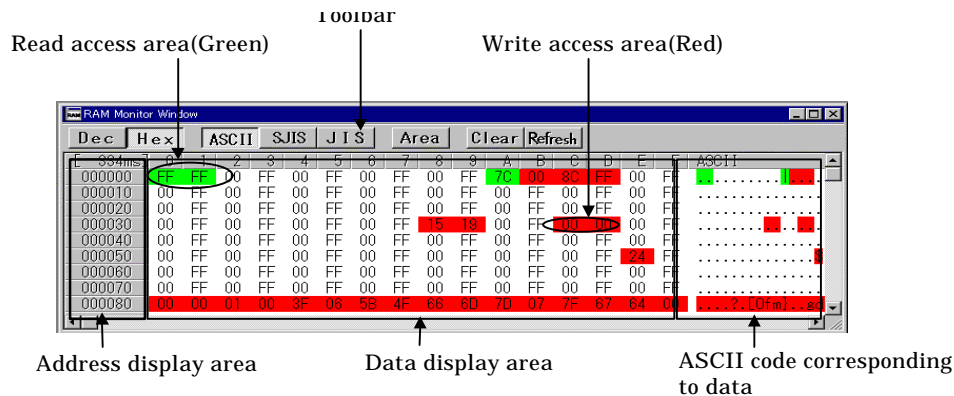

- Double-click the address display area to change the display starting address. If the specified starting address is outside the RAM monitor area, the RAM monitor area also changes.
- The refresh rate during execution of the target program is displayed in the refresh rate display area ("Address" is displayed when the target program is not running). Note that, due to the operating conditions, the refresh rate may be slightly slower than that specified. The following items have a great influence on the refresh rate:
 - Performance of and load on the host computer
 - Window size (amount of memory display)
 - The number of rewrites required (the number of memory addresses at which values have been changed)
- The background color for the display of data and ASCII code changes according to the access attribute, as follows (the background color is white if there is no access):
 - Areas accessed by READ: Green
 - Areas accessed by WRITE: Red

You can change the background color by selecting [Option] -> [Color]. The display of access attributes is cleared (the addresses are displayed as if not accessed) when you select [Option] -> [View] -> [Clear] and after downloading a target program.

Note:

- If you are displaying data in the RAM monitor area in 2-byte units (by selecting Word under [Option] -> [View] -> [Data Length]), the memory access attribute may differ for each of the bytes. If there are such mismatches in the access attributes within one data item, the data item is displayed in parentheses, as shown below. Note that the memory display background color is set to the color for the access attribute of the 1st byte.

Display when access attributes are mismatched between different bytes of the data.

Address	0	2	4	6	8	A	C	E	ASCII
00A0	0000	0000	0000	0000	0000	0000	0000	0000
00B0	0000	0000	0000	0000	0000	0000	0000	0000
00C0	0000	0000	0000	0000	0000	0000	0000	0000
00D0	0000	0000	0000	0000	0000	0000	0000	0000
00E0	0000	0000	0000	0000	0000	0000	0000	0000
00F0	0000	0000	0000	0000	0000	0000	0000	0000
0100	0000	(0000)	0000	0000	0000	0000	0000	0000
0110	077F	(0177)	(0000)	0000	0000	0000	0000	0000
0120	0000	0000	0000	0000	0000	0000	0000	0000

Display when access attribute is identical for all bytes of the data.

1.7.2 RAM Monitor Window Toolbar

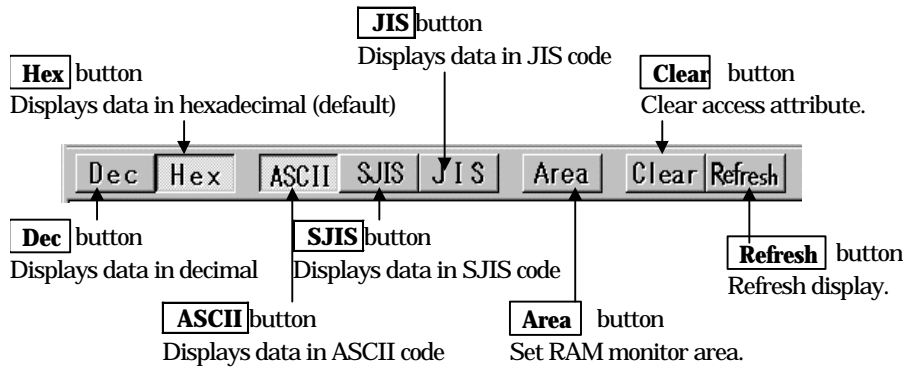

1.7.3 Extended Menus in the RAM Monitor Window

When the RAM Monitor Window is active in the PD38SIM main display area, the [Option] menu contains the following items:

Menu	Menu options	Function	Shortcut keys
Option	Font...	Change font.	—
	View	Change contents of display.	—
	Address...	Display from specified address.	—
	Data Length	Specify data length.	—
	Byte	Display in 1-byte units.	—
	Word	Display in 2-byte units.	—
	Radix	Specify radix.	—
	Dec	Display in decimal.	—
	Hex	Display in hexadecimal.	—
	Ascii	Display as ASCII characters.	—
	SJIS	Display as SJIS characters.	—
	JIS	Display as JIS characters.	—
	Refresh	Refresh display.	—
	Clear	Clear access attribute.	—
	Layout	Set layout.	—
	Ascii	Turn on/off ASCII strings.	—
RAM Monitor Area...	Set RAM monitor area.	—	
Color...	Set color of access attribute display.	—	
Sampling period...	Set sampling period for RAM monitor.	—	

1.8 ASM Watch Window

The ASM Watch Window allows you to check the values at any specified address. You can specify the point to watch as an address (symbol or global variable), as an address and bit No., or as a bit symbol. The display is updated after each command is executed.

1.8.1 Structure of ASM Watch Window

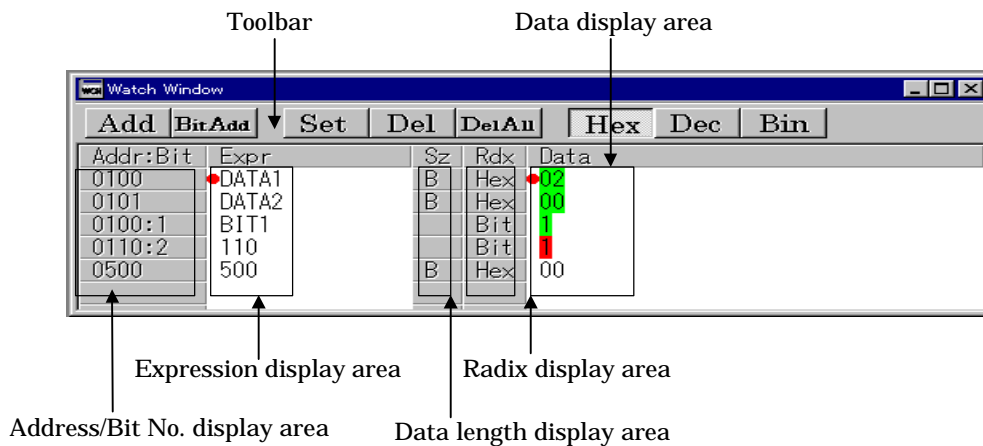

- The cursor position is indicated by a red mark in the address display area and data display area. Click either area or use the [UP-button] and [DOWN-button] cursor keys to move the cursor.
- Double-click the radix (Rdx) display area to switch the current radix for the data displayed in that area as follows:
... -> hex -> decimal -> binary -> hex -> ...
- Provided the watchpoint is within the RAM monitor area, the contents of the display are regularly updated while the target program is executing.
- Information about set watchpoints is stored in the Init file when you close the ASM Watch Window or exit PD38SIM. When you re-open the ASM Watch Window, the previously set watchpoints are automatically restored.
- In the case of the ASM Watch Window, the addresses of any previously set watchpoints are recalculated when you download a target program and the memory referenced using the new addresses. Thus there is no need to respecify the watchpoint addresses even when they change as a result of changes in the program.
 - When the addresses of inactive watchpoints (indicated by "--<not active>--") are recalculated and the result is a valid address, the watchpoints automatically become active again.

1.8.2 ASM Watch Window Toolbar

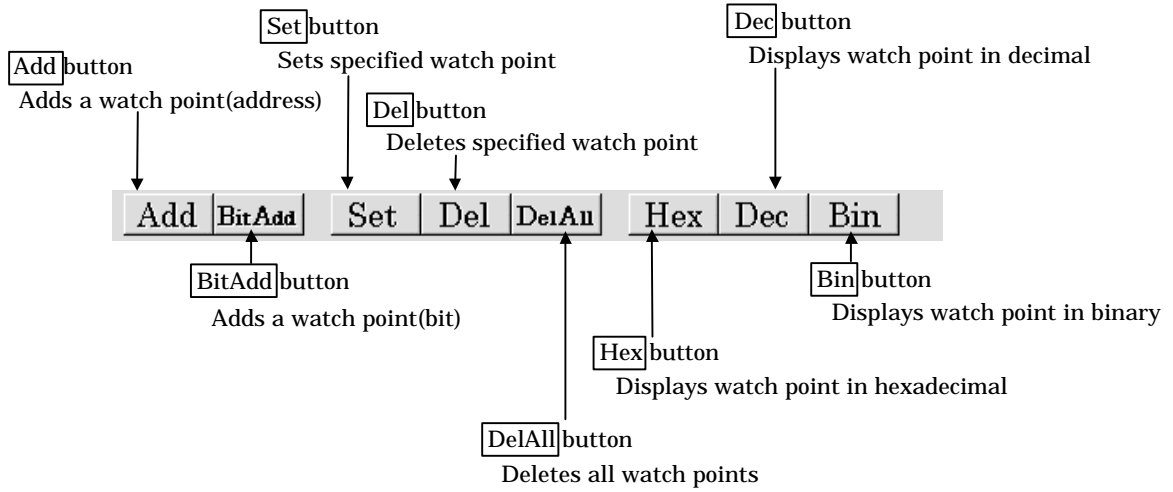

1.8.3 Extended Menus in the ASM Watch Window

When the ASM Watch Window is active in the PD38SIM main display area, the [Option] menu contains the following items:

Menu	Menu options	Function	Shortcut keys
Option	Font...	Change font.	–
	Watch	Register / delete watch point.	–
	Add...	Register watch point.	Ctrl+A
	Bitadd...	Register bit-level watch point.	Ctrl+B
	Set...	Set new data to be written to selected watch point.	Ctrl+S
	Del	Delete selected watch point.	Ctrl+D
	DelAll	Delete all watch points.	–
	Radix	Change display radix.	–
	Bin	Display value at selected watch point in binary.	–
	Dec	Display value at selected watch point in decimal.	–
	Hex	Display value at selected watch point in hexadecimal.	–
	Layout	Set layout.	–
	Address Area	Turn on/off address/bit area.	–
	Size Area	Turn on/off data size area.	–
	RAM Monitor	Display RAM monitor.	–
	Sampling period...	Set sampling period for RAM monitor.	–
	Color...	Set color of access attribute display.	–
	File	Watch point save/load.	–
	Save	Watch point save.	–
	Load	Watch point load.	–

1.9 C Watch Window

The C Watch Window displays C expressions and their values (results of calculations). The C expressions displayed in the C Watch Window are known as C watchpoints. The displays of the results of calculating the C watchpoints are updated each time a command is executed.

1.9.1 Structure of C Watch Window

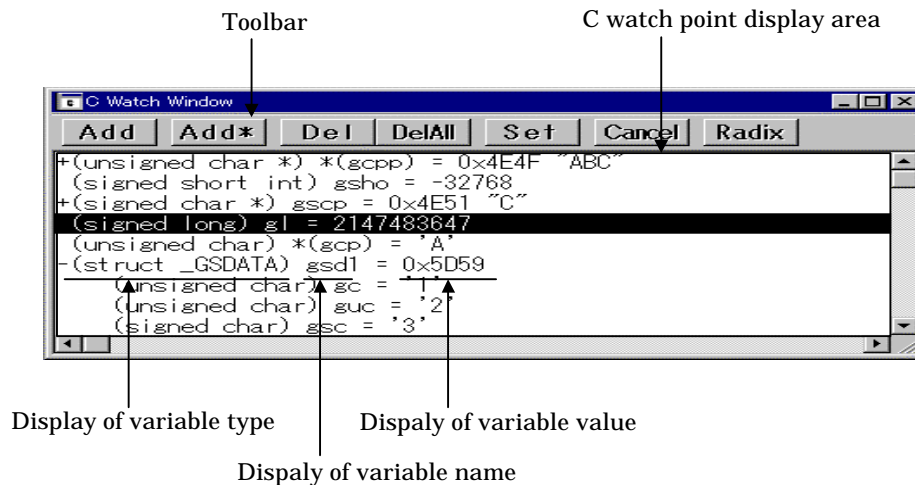

- You can use the following as C watchpoints:
 - C symbols
Variable names and function names defined in the C source program.
 - Expressions including C symbols (C expressions)
For details of tokens that can be used in C expressions, see Section 3.1, "Writing C Expressions" in the Reference part.
- If a C expression cannot be correctly calculated (it includes an undefined symbol, for example), it is recorded as an inactive C watchpoint. Inactive C watchpoints are not included in the display of calculated results. However, if an inactive C watchpoint is recalculated and the result is valid, it becomes an active C watchpoint.
- Note that values cannot be assigned in the following C watchpoints:
 - Floating point type variables
 - Bit field type variables
 - Register variables
 - C watchpoints that do not indicate addresses
- Double-click the radix (Rdx) display area to switch the current radix for the data displayed in that area as follows:
... -> hex -> decimal -> binary -> hex -> ...
- When RAM monitor function is effective and the C watch points are within the RAM monitor area, the displayed values are updated during execution of the target program. And the values of the accessed variables are colored.
The selecting the menu [Option] -> [RAM Monitor] -> [Enable] makes RAM monitor function effective or not.

- Information about set C watchpoints is stored in the C watchpoint information file when you close the C Watch Window or exit PD38SIM. When you re-open the C Watch Window, previously set C watchpoints are automatically restored.
 A C watchpoint information file is created for each loaded object file (and includes information on the name of the loaded object file).
 When you set a new C watchpoint, the program first searches for a C watchpoint information file with information on a file with the same name as the currently loaded object file. If an appropriate file is found, C watchpoints are restored from the information in that file.

1.9.2 C Watch Window Toolbar

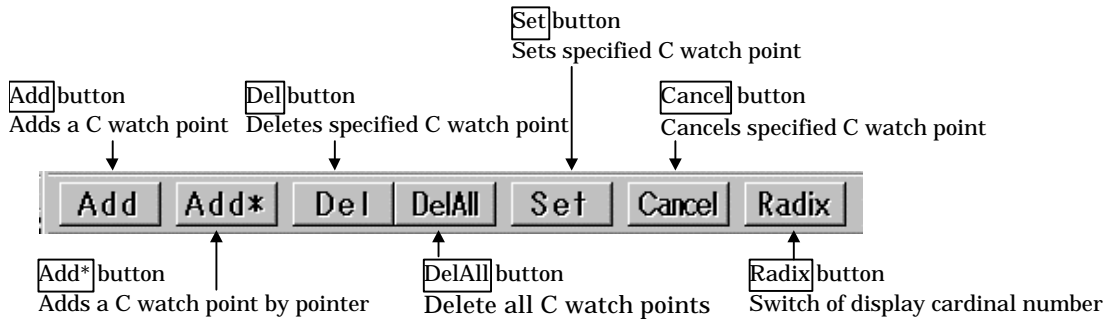

- You can delete or set new values for C watchpoints selected by clicking in the C watchpoint display area. You cannot delete only additional information such as the members of structures displayed when recording C watchpoints.
- The addresses for pointers, etc., are displayed in hexadecimal regardless of the display radix. See Section 3.2, "Display Format of C Expressions" in the Reference part for details of display formats.

1.9.3 Extended Menus in the C Watch Window

When the C Watch Window is active in the PD38SIM main display area, the [Option] menu contains the following items:

Menu	Menu options	Function	Shortcut keys
Option	Font...	Change font.	—
	Watch	Register/delete C watch point.	—
	Add...	Register C watch point.	—
	Add Pointer...	Register C watch point (pointer).	—
	Del	Delete selected C watch point.	—
	Set...	Set new value for selected C watch point.	—
	Cancel	Cancel selection of C watch point.	—
	Del All	Delete all C watch points.	—
	View	Change contents of display.	—
	Radix	Change radix.	—
	Layout	Turn on/off type name.	—
	Sort	Sort.	—
	Display String	Display the string / Display character.	—
	RAM Monitor	Display RAM monitor.	—
	Enable	Turn on/off RAM monitor area.	—
	RAM Monitor Area...	Set RAM monitor area.	—
	Color...	Set color of access attribute display.	—
	Sampling period...	Set sampling period for RAM monitor.	—
	Clear	Clear access attribute.	—

1.10 Local Window

The Local Window lists local variables in the C function with their values. The display is updated after each command is executed.

1.10.1 Structure of Local Window

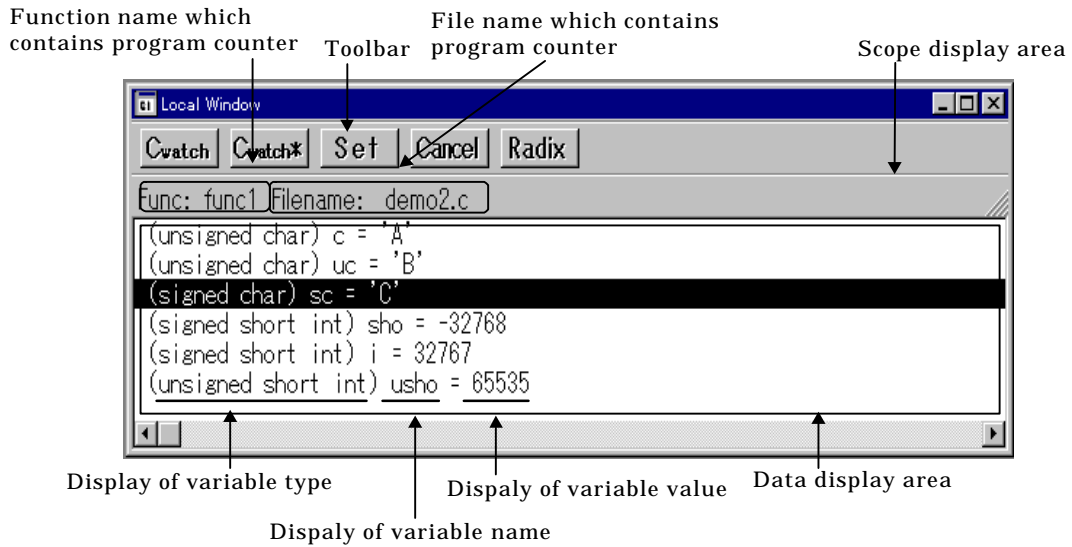

- When performing step execution, etc., and there is a change in the function that includes the address specified by the program counter, previously displayed variables are cleared and the local variables in the new function are automatically displayed.

1.10.2 Local Window Toolbar

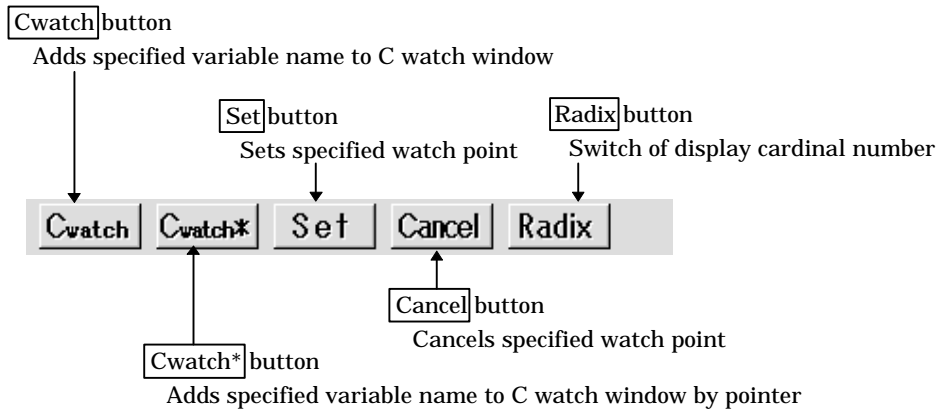

- You can register variables selected by clicking in the data display area as C watchpoints in the C Watch Window, or change their values. You can use C expressions to set the values. For details of tokens that can be used in C expressions, see Section 3.1, "Writing C Expressions" in the Reference part.
- The addresses for pointers, etc., are displayed in hexadecimal regardless of the display radix. See Section 3.2, "Display Format of C Expressions" in the Reference part for details of display formats.

1.10.3 Extended Menus in the Local Window

When one of the Local Window is active in the PD38SIM main display area, the [Option] menu contains the following items:

Menu	Menu options	Function	Shortcut keys
Option	Font..	Change font.	-
	W <u>atch</u>	Operations related to C-function.	-
	C <u>w</u> atch	Register selected C variable as C watch point.	-
	C <u>w</u> atch <u>P</u> ointer	Register pointer of selected C variable as C watch point.	-
	S <u>e</u> t..	Set new value for selected C variable.	-
	C <u>a</u> ncel	Cancel selection of C variable.	-
	V <u>iew</u>	Change contents of display.	-
	R <u>a</u> dix	Change radix.	-
	L <u>a</u> ayout	Turn on/off type name.	-
	S <u>o</u> rt	Sort.	-
D <u>i</u> splay S <u>tr</u> ing	Display the string / Display character.	-	

1.11 File Local Window

The File Local Window lists local variables in the C file with their values. The display is updated after each command is executed.

1.11.1 Structure of File Local Window

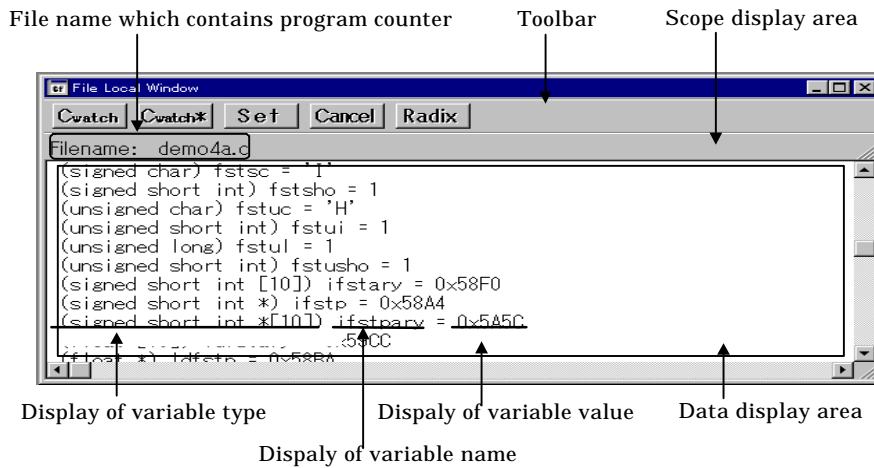

- When performing step execution, etc., and there is a change in the file that includes the address specified by the program counter, previously displayed variables are cleared and the local variables in the new source file are automatically displayed.

1.11.2 File Local Window Toolbar

The File Local Window toolbar is the same as that in the Local Window. See Section 1.10.2, "Local Window Toolbar" under Window Functions for details.

1.11.3 Extended Menus in the File Local Window

When one of the File Local Window is active in the PD38SIM main display area, the [Option] menu contains the following items:

Menu	Menu options	Function	Shortcut keys
Option	Font...	Change font.	–
	Watch	Operations related to C-function.	–
	Cwatch	Register selected C variable as C watch point.	–
	CwatchPointer	Register pointer of selected C variable as C watch point.	–
	Set...	Set new value for selected C variable.	–
	Cancel	Cancel selection of C variable.	–
	View	Change contents of display.	–
	Radix	Change radix.	–
	Layout	Turn on/off type name.	–
	Sort	Sort.	–
	Display String	Display the string / Display character.	–
	RAMMonitor	Display RAM monitor.	–
	Enable	Turn on/off RAM monitor area.	–
	RAMMonitor Area...	Set RAM monitor area.	–
	Color...	Set color of access attribute display.	–
	Sampling period...	Set sampling period for RAM monitor.	–
	Clear	Clear access attribute.	–

1.12 Global Window

The Global Window lists C global variables and their values. The display is updated after each command is executed.

1.12.1 Structure of Global Window

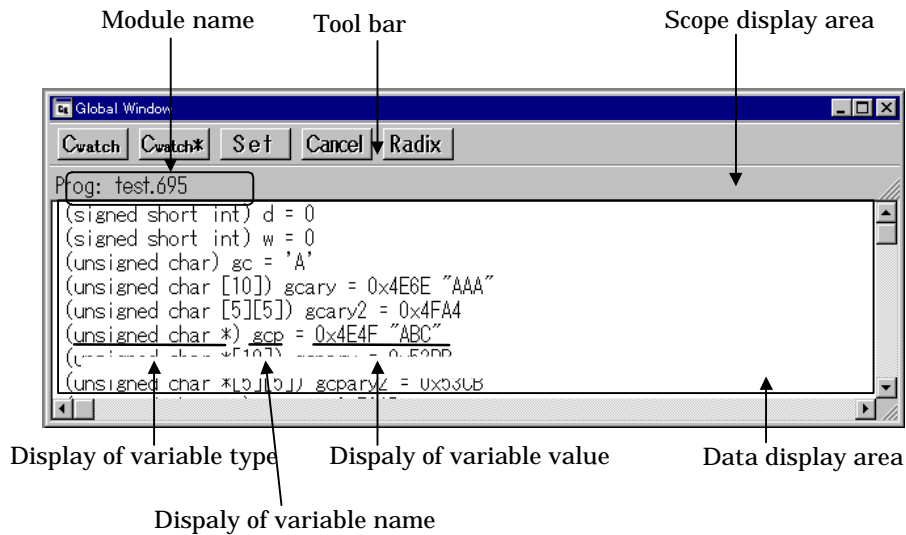

1.12.2 Global Window Toolbar

The Global Window toolbar is the same as that in the Local Window. See Section 1.10.2, "Local Window Toolbar" under Window Functions for details.

1.12.3 Extended Menus in the Global Window

When the Global Window is active in the PD38SIM main display area, extended menus for the Global Window are allocated to the [Option] menus. The extended menus of the Global Window are identical to those of the Local Window. See Section 1.11.3, "Extended Menu in the Local Window" under Window Functions for details.

1.13 Script Window

The Script Window displays the execution of text-format script commands and the results of that execution. Script commands can be executed using a script file or interactively. You can also write script commands in the script file so that they are automatically executed. The results of script command execution can also be stored in a previously specified log file.

1.13.1 Structure of Script Window

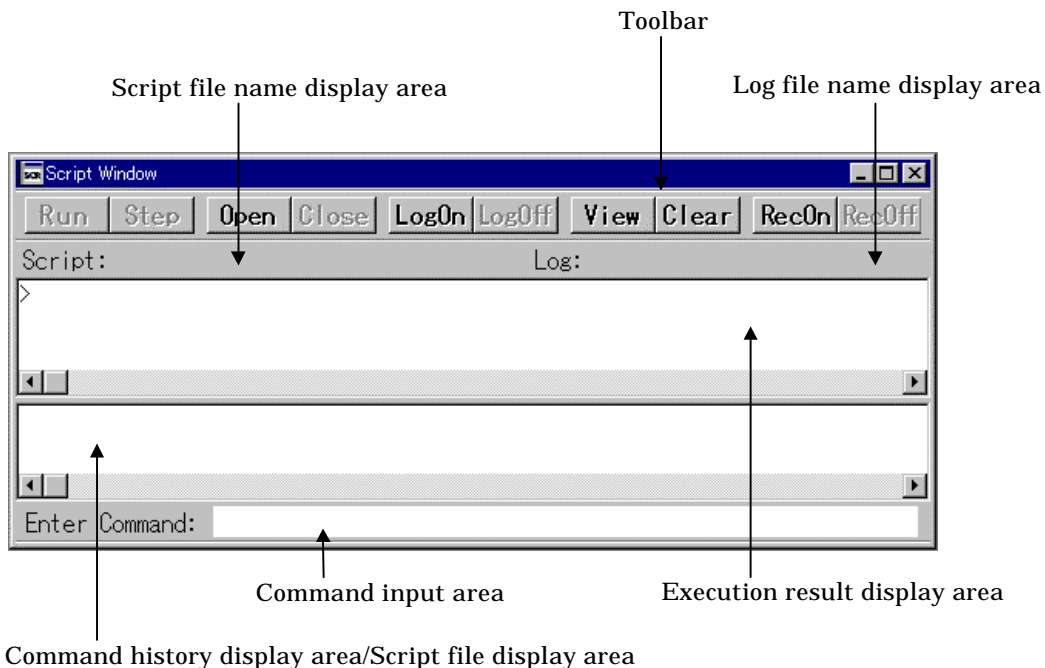

- The Script Window has a view buffer that stores the results of executing the last 1000 lines. The results of execution can therefore be stored in a file (view file) without specifying a log file.
- When a script file is opened, the command history area changes to become the script file display area and displays the contents of the script file. When script files are nested, the contents of the last opened script file are displayed. The script file display area shows the line currently being executed in inverse vide.
- When a script file is open, you can invoke script commands from the command input area provided the script file is not being executed.
- The Script Window can record the history of the executed commands to a file. This function is not the same as the log function. This function records not the result but only the executed commands, so the saved files can be used as the script files.

1.13.2 Script Window Toolbar

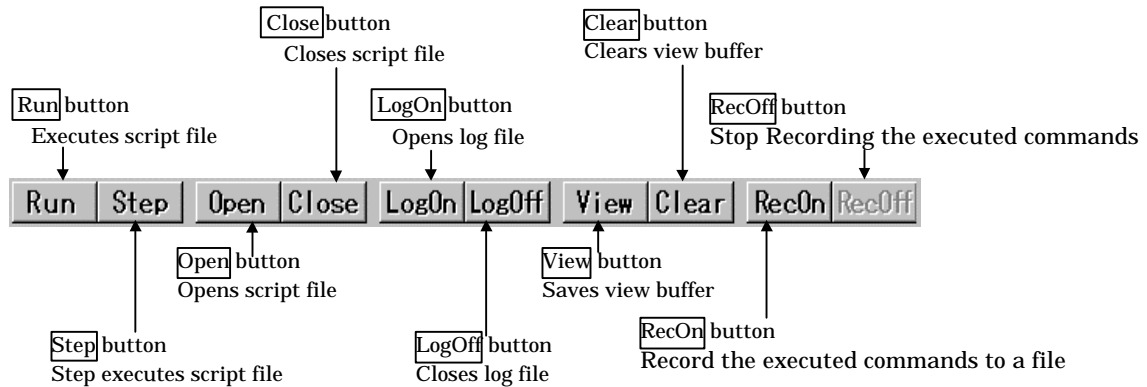

1.13.3 Extended Menus in the Script Window

When the Script Window is active in the PD38SIM main display area, the [Option] menu contains the following items:

Menu	Menu options	Function	Shortcut keys
Option	Font...	Change font.	-
	Script	Script file operations.	-
	Open...	Open script file.	-
	Run	Run script file.	-
	Stop	Stop execution of script file.	-
	Step	One-step execution of script file.	-
	Close	Close script file.	-
	View	View buffer operations.	-
	Save...	Save view buffer file.	-
	Clear	Clear view buffer.	-
	Log	Log file operations.	-
	On...	Open log file (start output to file).	-
	Off	Close log file (stop output to file).	-
	Record	Record the executed commands.	-
	On...	Record the executed commands to a file.	-
	Off	Stop Recording the executed commands.	-

1.14 I/O Window

This window is used to set and display virtual port input/outputs or virtual interrupts. Virtual port inputs, virtual interrupt settings, and virtual port output results can be displayed for your reference in numeric or graphic mode.

For details about virtual port input/outputs, and on how to set virtual interrupts, refer to "High-end Debugging" described later in this manual.

The functions, screen configuration, tool bar, and menus of the I/O Window are explained here.

- Up to a total of 20 virtual port inputs and virtual interrupts can be set. Up to 20 virtual port outputs can be set.

1.14.1 Virtual Port Input

Virtual Port Input refers to a function that defines changes in the data that is input from external sources to a specified memory address. Use of this function makes it possible to simulate data inputs to the ports defined in the SFR.

The defined input data can be referenced by displaying it in chart, numeric (hexadecimal), or graphic mode.

There are following three types of virtual port inputs:

(1) Cycle synchronized input

The input data can be written to memory when program execution has reached a specified number of cycles. The data size that can be input is one byte.

The diagram below shows an example of a virtual port input that is synchronized to machine cycles.

Example where data is input to address 0

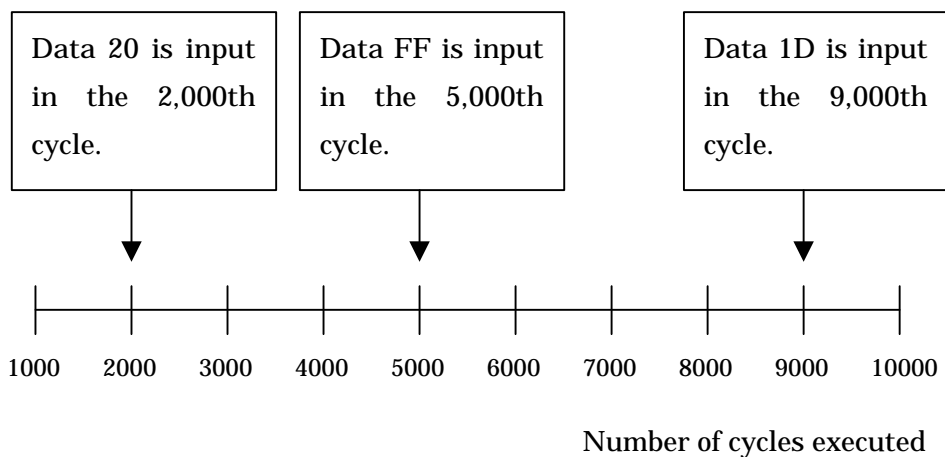

As shown above, data can be input to memory address 0 in any desired cycle as specified by the user.

(2) Read access synchronized input

Data can be input when the program accesses a specified memory location for read. The data size that can be input is one byte. The diagram below shows an example of a virtual port input that is synchronized to memory accesses for read.

Shown in the sample program below is a function that reads data from port0 (address0).

```

T_PORT0:          .byte          0000H
                  .section        Z
                  .org           0040H
                  :
                  :
READ_PORT:
                  A = [T_PORT0]
                  :
                  :
    
```

This function aims to assign the value of port 0 to accumulator. In such a case, a value can be assigned to accumulator by entering it to port 0 when the program accesses port 0 (address 0) for read.

To support processing of functions like this, PD38SIM provides a function that allows you to define the data to be input according to a number of times the specified memory address is read (a virtual input port synchronized to memory accesses for read). By using this function, you can perform an operation where data 0x10 is input to memory address 0 when address 0 is read first and data 0x20 is input to said memory address when the address is read next.

Number of times the address 0 is read	Data input to address 0
First	0x10
Second	0x20
Third	0x30
:	:
:	:

(3) Interrupt synchronized input

Data can be input to a specified memory location when a virtual interrupt occurs.

The data size that can be input is one byte.

The diagram below shows an example of a virtual port input that is synchronized to interrupts.

Shown in the sample program below is the case where data is read from port 1 (address 2) using an interrupt handler routine.

```

                                .section      DATA
                                .org          0080H
T_PORT1:                        .byte       0002H

                                .section      PROGRAM
                                .org          8000H

;
INT_2

                                A = [T_PORT1]
                                :
                                :
                                RTI

```

This interrupt handler routine aims to assign the value of port 1 to accumulator when a virtual interrupt is generated. In such a case, a value can be assigned to accumulator by entering it to port 1 when a virtual interrupt is generated.

It is assumed that interrupts are generated using a separately available virtual interrupt function. (For details, refer to the virtual interrupt function described later in this manual.)

To support processing of interrupt handlers like this, PD38SIM provides a function that allows you to define the data to be input according to a number of times a virtual interrupt is generated (a virtual input port synchronized to virtual interrupts). By using this function, you can perform an operation where data 0xFF is input to memory address 2 when the virtual interrupt occurs first and data 0xFE is input to said memory address when the virtual interrupt occurs next time.

Number of times a virtual interrupt is generated	Data input to address 2
First	0xFF
Second	0xFE
Third	0xFD
:	:
:	:

1.14.2 Virtual Port Output

Virtual Port Output is a function that when data is written to some memory address by the program, allows the written data value to be recorded along with the cycle in which the data was written.

The recorded data can be displayed for your reference in chart, numeric, or graphic mode. The maximum number of data that can be recorded by this function is 30,000 entries counted from the beginning of program execution.

For example, if data is written to port 0 (address 0) by executing a program like the one shown below,

```

T_PORT0:          .byte          0000H

DATABUFF:         .section       Z
                  .blkb         1
                  :
OUT_PORT0:        [T_PORT0] = [DATABUFF]
    
```

the data written to address 0 is recorded along with the cycle count in which the data was written.

1.14.3 Virtual Interrupt

This function defines interrupt generation. Using this function, you can generate timer interrupts in a simulated manner without having to actually generate them.

There are following three types of virtual interrupts:

(1) Cycle synchronized interrupt

A specified virtual interrupt can be generated when program execution has reached a specified number of cycles.

The diagram below shows an example of a virtual interrupt that is synchronized to machine cycles.

Example where virtual interrupt of vector address. 0xffec (timer 2) is defined

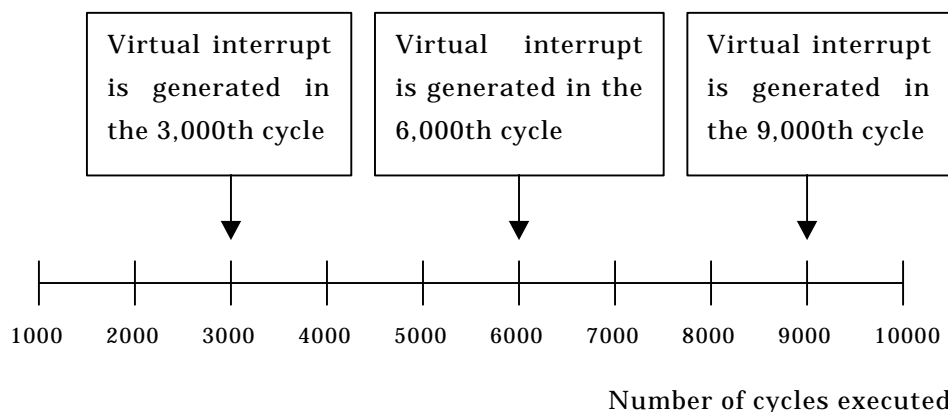

As shown above, virtual interrupts (in this case, timer 2 interrupt) can be generated in any desired cycle.

(2) Executed address synchronized interrupt

Virtual interrupts can be generated when the program has executed a specified address. The diagram below shows an example of a virtual interrupt that is synchronized to executed addresses.

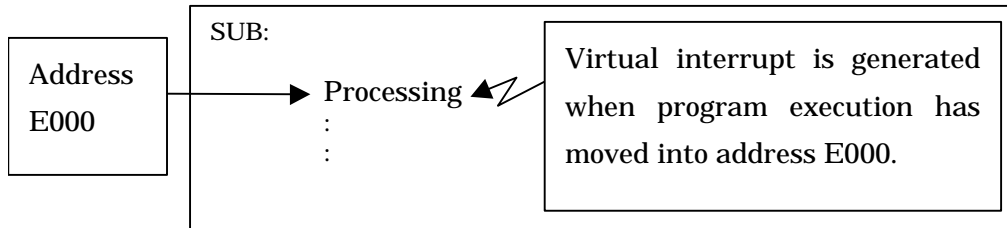

As shown above, a specified virtual interrupt can be generated when program execution has moved into address E000.

By using this function, you can specify that a virtual interrupt be generated when address E000 is executed first by the program, and that no virtual interrupt be generated when the address is executed next, as shown below.

Number of times the address E000 is executed	Whether virtual interrupt is generated
First	Virtual interrupt is generated
Second	Virtual interrupt is not generated
Third	Virtual interrupt is generated
:	:
:	:

1.14.4 Screen Configuration of I/O Window

This window is split into three sections, each displaying the setup contents of virtual port inputs, the output results of virtual port outputs, and the setup contents of virtual interrupts.

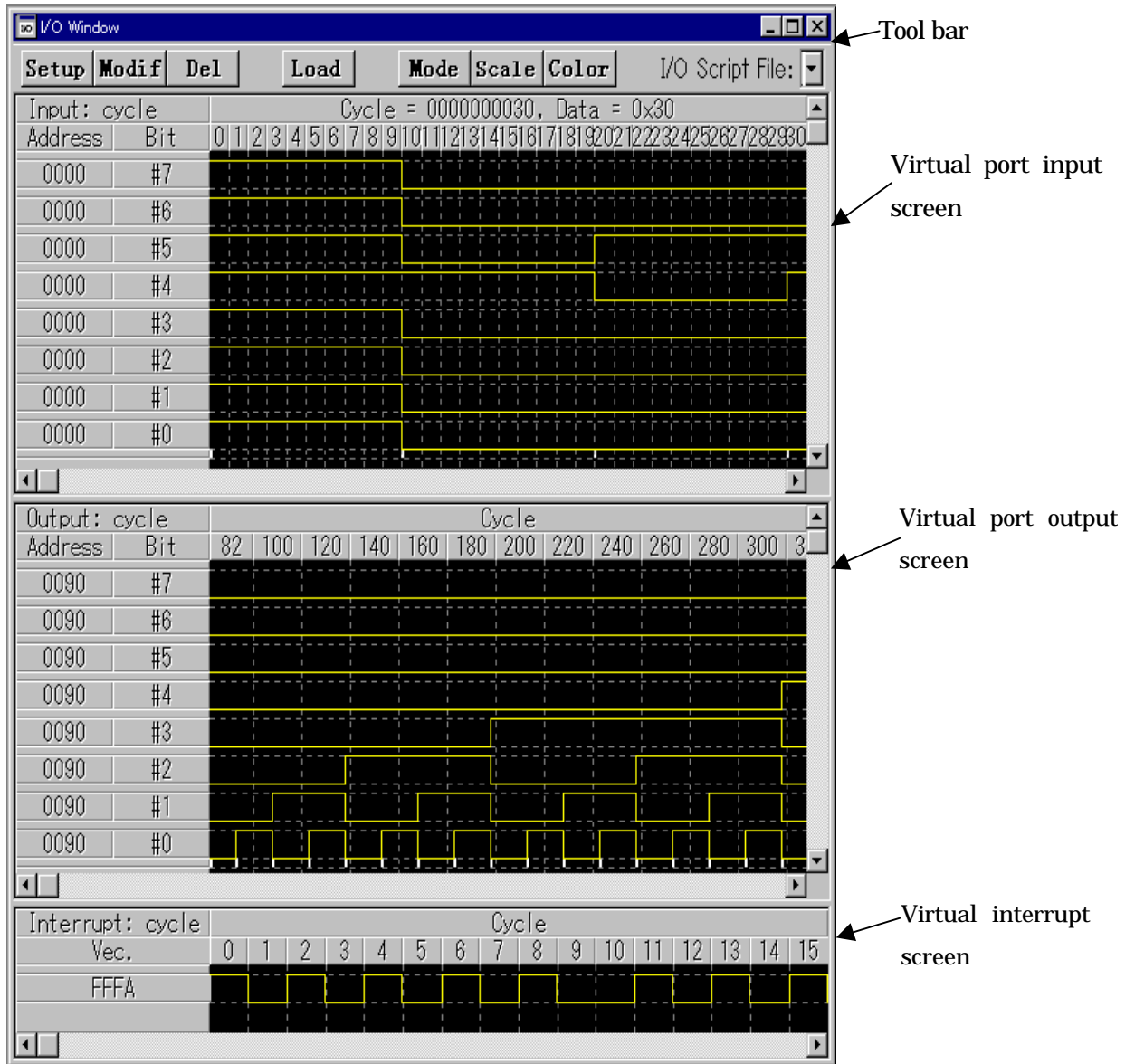

Each screen is detailed in the pages to follow.

1.14.5 Structure of Virtual Port Input Screen

1.14.5.1 Screen structure for cycle-synchronized inputs

If you've set virtual port inputs that are synchronized to machine cycles, they can be displayed in one of the three modes shown below. The display modes can be changed from the Mode menu.

(1) Chart mode (displayed in units of bits)

The virtual port input that has been set is displayed in chart mode in units of bits.

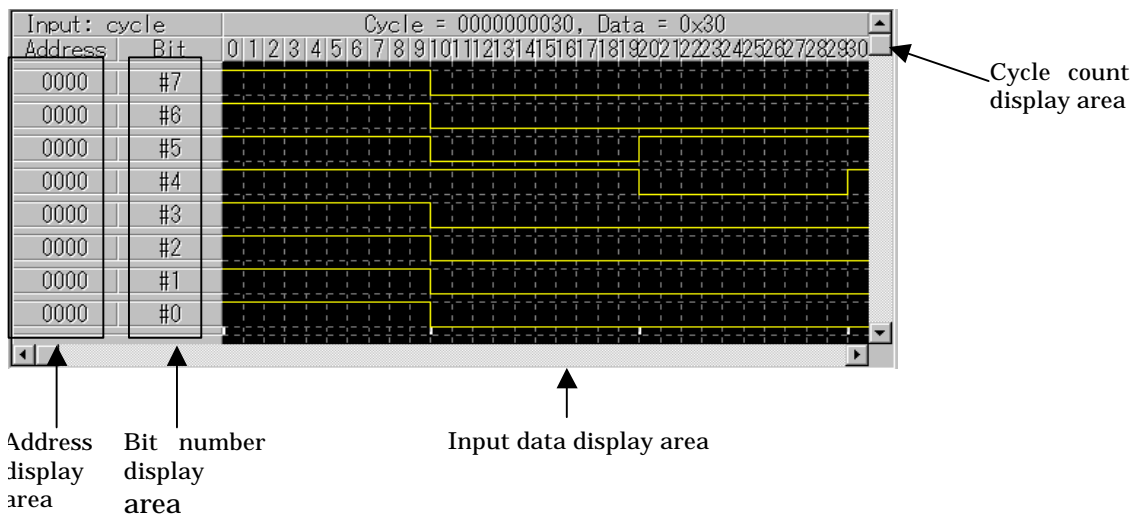

Address display area

It displays the memory address to which a virtual port is input.

Bit number display area

It displays bit numbers of memory to which a virtual port is input.

Input data display area

It displays the virtual port input data that has been set in chart mode in units of bits.

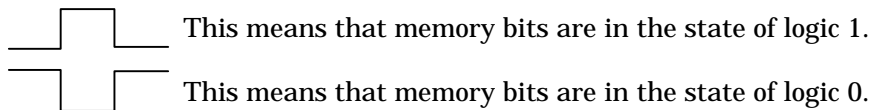

The short white lines appearing at the bottom of the input data display area indicate points at which data are input.

To reference data values, move the mouse cursor into this area and the value and the cycle count of the data at which the cursor is positioned will be displayed in the cycle count display area.

Cycle count display area

It displays cycle counts.

- (2) Graphic mode (displayed in units of bytes)
 The virtual port input that has been set is displayed in graphic mode in units of bytes.

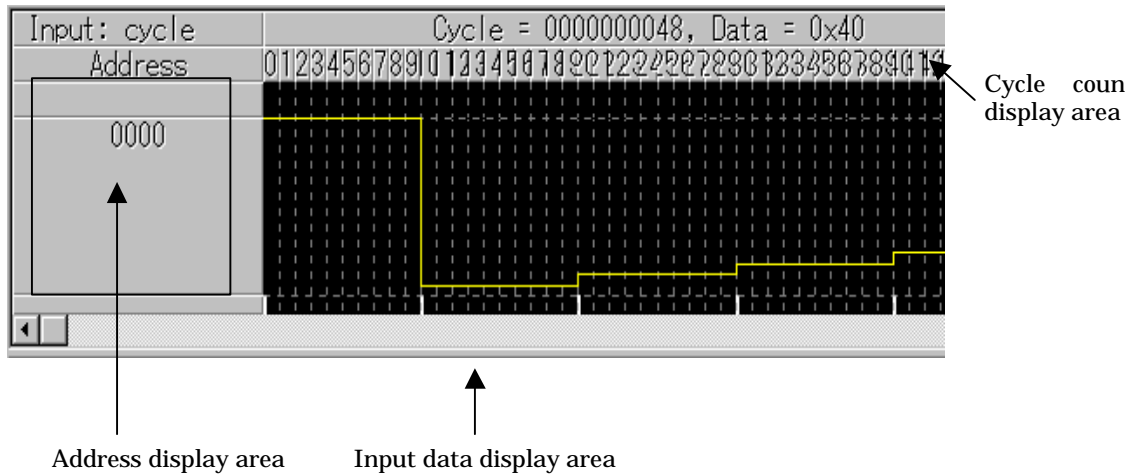

Address display area

It displays the memory address to which a virtual port is input.

Input data display area

It displays the virtual port input data that has been set in graphic mode.
 The peaks in this graph represent data values derived by equally dividing the height of the data-displaying area by 255 (maximum value of 1-byte data).
 The short white lines appearing at the bottom of the input data display area indicate points at which data are input.
 To reference data values, move the mouse cursor into this area and the value and the cycle count of the data at which the cursor is positioned will be displayed in the cycle count display area.

Cycle count display area

It displays cycle counts.

(3) Hexadecimal mode

The virtual port input that has been set is displayed in hexadecimal mode.

Input: cycle	Cycle = 0000000022, Data = 0x20																					
Address	0	1	2	3	4	5	6	7	8	9	10	11	12	13	14	15	16	17	18	19	20	21
0000	FF								10													20

Address display area (points to 0000)
 Input data display area (points to 10)
 Cycle count display area (points to 22)

Address display area

It displays the memory address to which a virtual port is input.

Input data display area

It displays the virtual port input data that has been set by hexadecimal numbers.

To reference data values, move the mouse cursor into this area and the value and the cycle count of the data at which the cursor is positioned will be displayed in the cycle count display area.

Cycle count display area

It displays cycle counts.

1.14.5.2 Screen structure for read access-synchronized inputs

When you've set virtual port inputs that are synchronized to memory accesses for read, a display screen configured as shown below will appear.

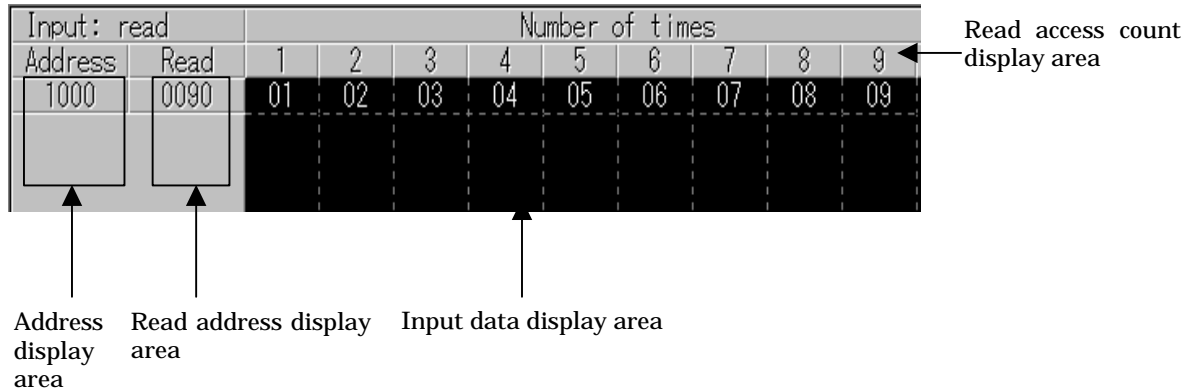

Address display area

It displays the memory address to which a virtual port is input.

Read address display area

It displays the address to be monitored for read access.

Input data display area

It displays the virtual port input data that has been set by hexadecimal numbers. To reference data values, move the mouse cursor into this area and the value and the read access count of the data at which the cursor is positioned will be displayed in the read access count display area.

Read access count display area

It displays read access counts.

1.14.5.3 Screen structure for interrupt-synchronized inputs

When you've set virtual port inputs that are synchronized to virtual interrupts, a display screen configured as shown below will appear.

Input: interrupt		Number of times								
Address	Vec.	1	2	3	4	5	6	7	8	9
1000	FFFA	01	02	03	04	05	06	07	08	09

← Virtual interrupt occurrence count display area

↑ Address display area ↑ Vector number display area ↑ Input data display area

Address display area

It displays the memory address to which a virtual port is input.

Vector number display area

It displays the virtual interrupt vector number to be monitored.

Input data display area

It displays the virtual port input data that has been set by hexadecimal numbers.

To reference data values, move the mouse cursor into this area and the value and the virtual interrupt occurrence count of the data at which the cursor is positioned will be displayed in the virtual interrupt occurrence count display area.

Virtual interrupt occurrence count display area

It displays virtual interrupt occurrence counts.

Virtual interrupt occurrence count display area

It displays virtual interrupt occurrence counts.

1.14.6 Structure of Virtual Port Output Screen

Virtual port output results can be displayed in one of the three modes shown below. The display modes can be changed from the Mode menu.

(1) Chart mode (displayed in units of bits)

Virtual port output results are displayed in chart mode in units of bits.

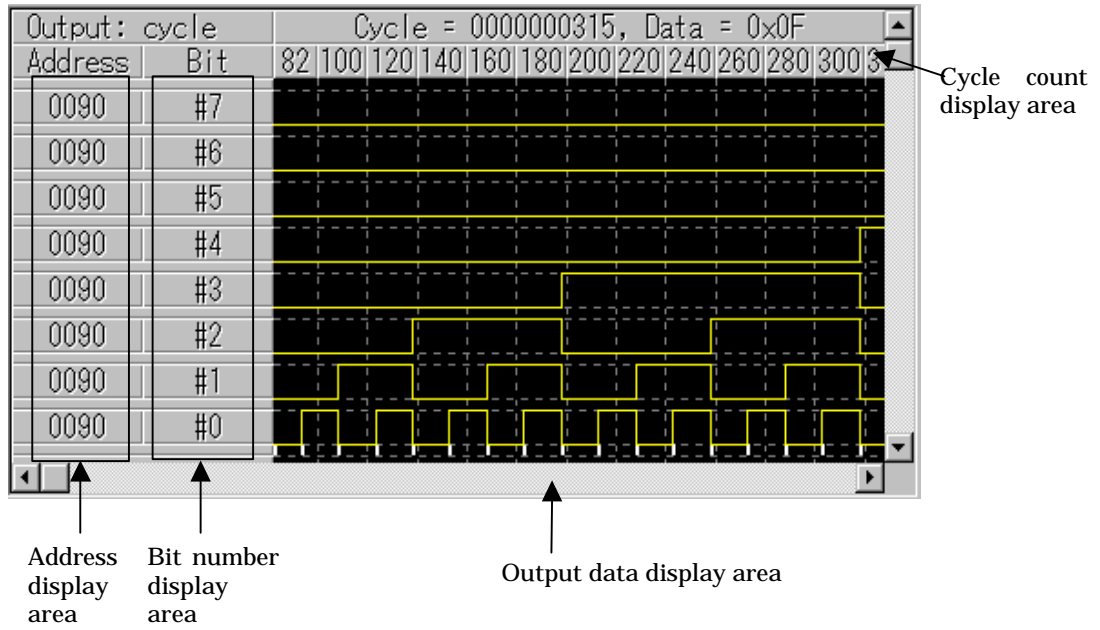

Address display area

It displays the address to be monitored for virtual port output.

Bit number display area

It displays bit numbers of memory being monitored for virtual port output.

Output data display area

It displays the data as virtual port output results in chart mode in units of bits.

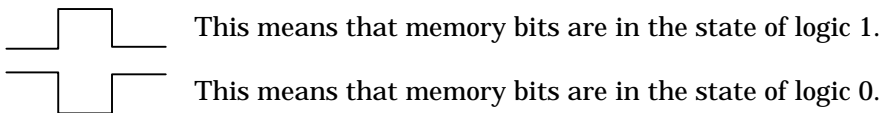

The short white lines appearing at the bottom of the output data display area indicate points at which data are output.

To reference data values, move the mouse cursor into this area and the value and the cycle count of the data at which the cursor is positioned will be displayed in the cycle count display area.

Cycle count display area

It displays cycle counts.

(2) Graphic mode (displayed in units of bytes)

Virtual port output results are displayed in graphic mode in units of bytes.

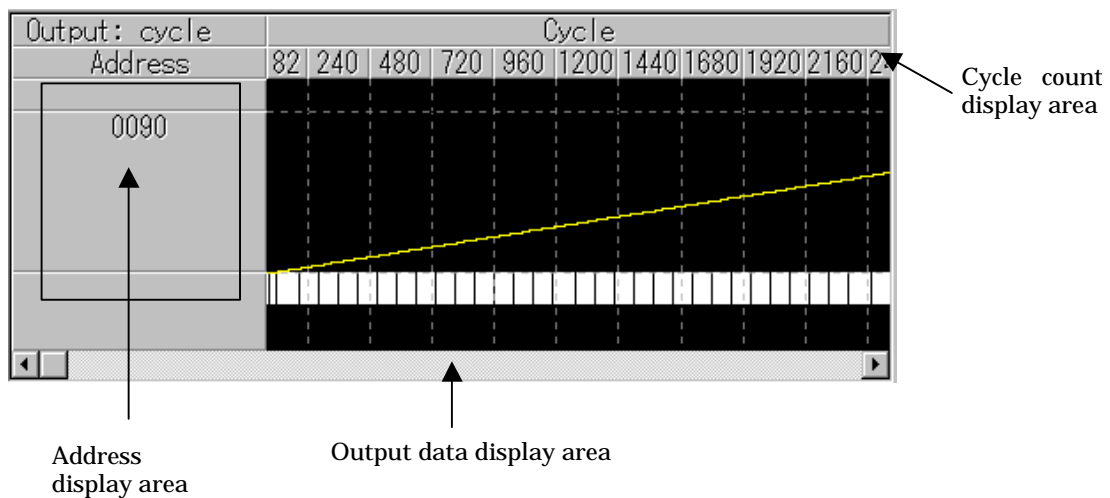
Address display area

It displays the address to be monitored for virtual port output.

Output data display area

It displays the data as virtual port output results in graphic mode in units of bytes.

The peaks [] in this graph represent data values derived by equally dividing the height of the data-displaying area by 255 (maximum value of 1-byte data).

The short white lines appearing at the bottom of the output data display area indicate points at which data are output.

To reference data values, move the mouse cursor into this area and the value and the cycle count of the data at which the cursor is positioned will be displayed in the cycle count display area.

Cycle count display area

It displays cycle counts.

(3) Hexadecimal mode

Virtual port output results are displayed in hexadecimal mode.

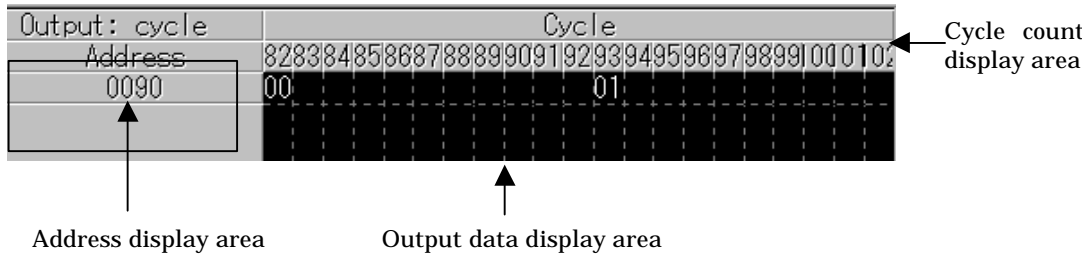

Address display area

It displays the address to be monitored for virtual port output.

Output data display area

It displays the data as virtual port output results by hexadecimal numbers.

To reference data values, move the mouse cursor into this area and the value and the cycle count of the data at which the cursor is positioned will be displayed in the cycle count display area.

Cycle count display area

It displays cycle counts.

1.14.7 Structure of Virtual Interrupt Screen

1.14.7.1 Screen structure for cycle-synchronized interrupts

When you've set virtual interrupts that are synchronized to machine cycles, a display screen configured as shown below will appear.

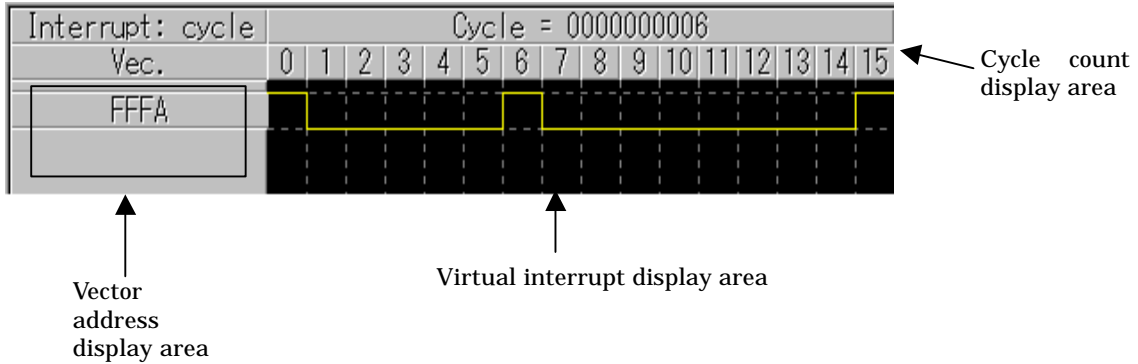

Vector number display area

It displays the vector number of a virtual interrupt.

Priority level display area

It displays the priority level of a virtual interrupt.

Virtual interrupt display area

It displays timing at which the virtual interrupt you've set is generated.

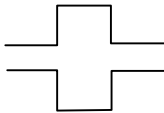

This means that a virtual interrupt is generated.

This means that a virtual interrupt is not generated.

Cycle count display area

It displays cycle counts.

1.14.7.2 Screen structure for executed address-synchronized interrupts

When you've set virtual interrupts that are synchronized to executed addresses, a display screen configured as shown below will appear.

Interrupt: address		Number of times									
Address	Vec.	1	2	3	4	5	6	7	8	9	10
803E	FFF6	*		*		*		*	*	*	

Execution count display area

Executed address display area

Vector address display area

Virtual interrupt display area

Executed address display area

It displays the fetch address (the address where the program is executed) at which time a virtual interrupt is generated.

Vector number display area

It displays the vector number of a virtual interrupt.

Priority level display area

It displays the priority level of a virtual interrupt.

Virtual interrupt display area

It displays timings by an asterisk (*) at which the virtual interrupt you've set is generated.

When an asterisk (*) is indicated, it means that a virtual interrupt is generated.

When an asterisk (*) is not indicated, it means that a virtual interrupt is not generated.

Execution count display area

It displays execution counts or a number of times the program has executed a specified address.

1.14.8 I/O Window Tool Bar

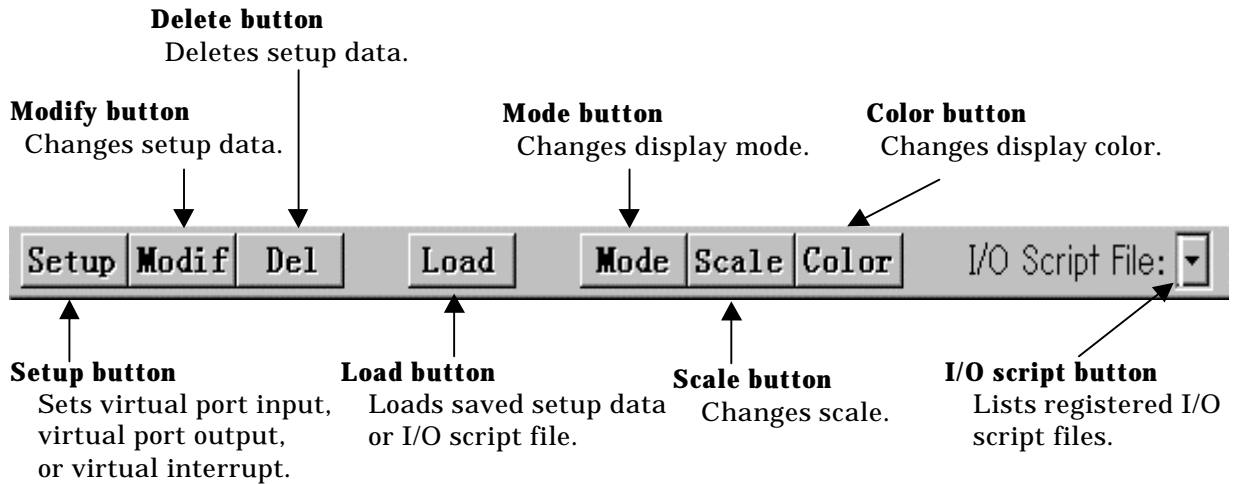

1.14.9 Extended Menu of I/O Window

If the I/O Window is active among the windows brought up in the main display area of PD38SIM, the [Option] menu has the following menu items assigned to it.

Menu	Menu item	Function	Shortcut key
Option	Font.....	Changes font.	-
	Setup...	Sets virtual port input, virtual port output, or virtual interrupt.	-
	Modify...	Changes set virtual port input or virtual interrupt.	-
	Delete...	Deletes set virtual port input, virtual port output, or virtual interrupt or user-created I/O script file.	-
	Load...	Loads saved virtual port input, virtual port output, or virtual interrupt or user-created I/O script file.	-
	Mode...	Changes display mode.	-
	Scale...	Changes display scale.	-
	Color...	Changes display color.	-

1.15 GUI Input Window

This window allows you to create a simple key input panel (buttons) of the user target system in a window and execute virtual port input or virtual interrupt by pressing one of the buttons you've created.

For details on how to create and set up a key input panel, refer to "High-end Debugging" described later in this manual.

The screen configuration, tool bar, and menus of the GUI Input Window are explained here.

One of the following three operations can be executed by pressing a button you've created in the key input panel of the GUI Input Window.

- Virtual port input
- Virtual interrupt generation
- Simultaneous generation of virtual interrupt and virtual port input

1.15.1 Screen Configuration of GUI Input Window

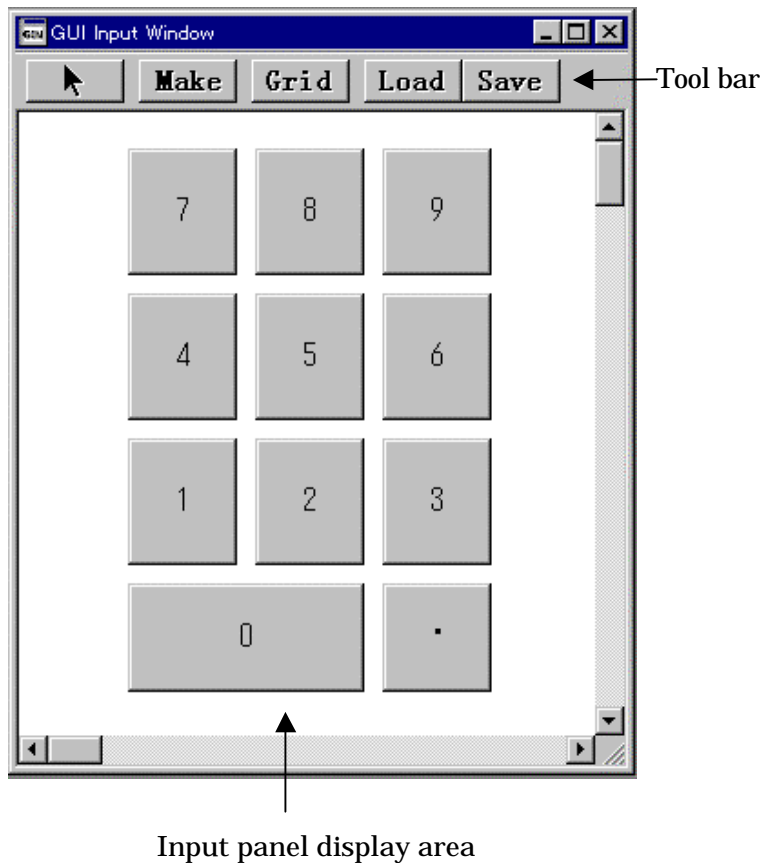

- You can create, edit, and move buttons in the input panel display area.
- The buttons you've created can be assigned labels (button names).
- By pressing the buttons you've created, you can generate virtual port input, virtual interrupt, or virtual port input plus virtual interrupt.
- The input panel you've created can be saved to a file (GUI input file).

1.15.2 Tool Bar of GUI Input Window

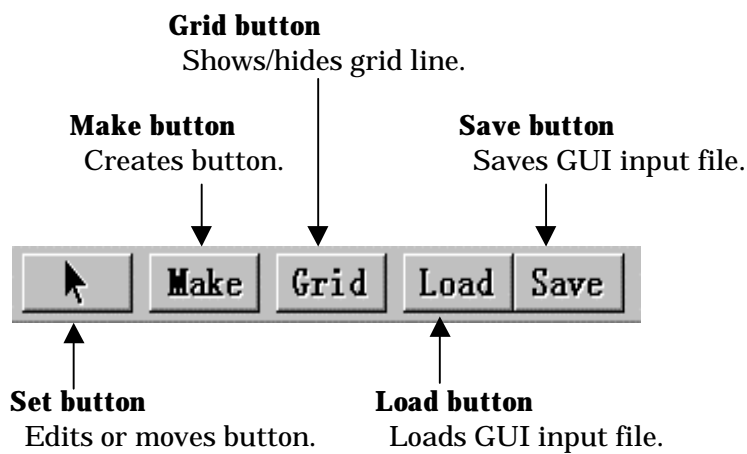

1.15.3 Extended Menu of GUI Input Window

If the GUI Input Window is active among the windows brought up in the main display area of PD38SIM, the [Option] menu has the following menu items assigned to it.

Menu	Menu item	Function	Shortcut key
Option	Set	Edits or moves button.	–
	Del	Deletes button.	–
	Copy	Copies button.	–
	Paste	Pastes button.	–
	Make Button	Creates button.	–
	Display Grid Line	Shows/hides grid line.	–
	Load...	Loads GUI input file.	–
	Save...	Saves GUI input file.	–

1.16 GUI Output Window

This window allows you to implement a simple output panel of the user target system in a window.

The following parts can be arranged in this output panel:

- Label (character string)
User-specified character strings are displayed or erased when some value is written to a specified memory address or according to logic 1 or 0 in a bit.
- LED
LEDs are lit when some value is written to a specified memory address or according to logic 1 or 0 in a bit.

For details on how to create and set up an output panel, refer to "High-end Debugging" described later in this manual.

The screen configuration, tool bar, and menus of the GUI Output Window are explained here.

1.16.1 Screen Configuration of GUI Output Window

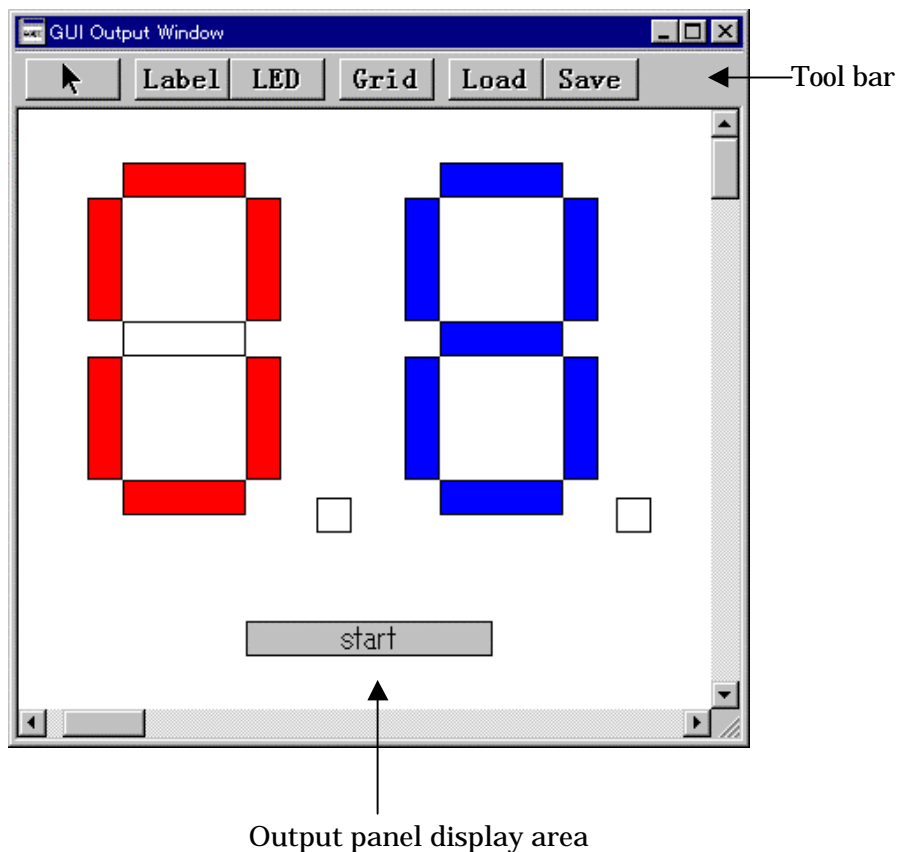

- You can create, edit, or move labels and LEDs in the output panel display area.
- The output panel you've created can be saved to a file (GUI output file).

1.16.2 Tool Bar of GUI Output Window

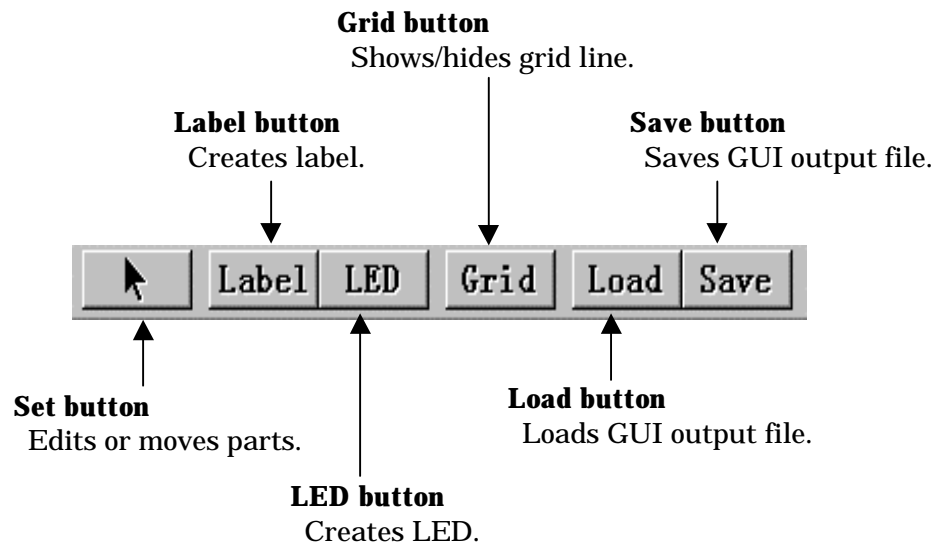

1.16.3 Extended Menu of GUI Output Window

If the GUI Output Window is active among the windows brought up in the main display area of PD38SIM, the [Option] menu has the following menu items assigned to it.

Menu	Menu item	Function	Shortcut key
Option	Set	Edits or moves parts.	–
	Del	Deletes parts.	–
	Copy	Copies parts.	–
	Paste	Pastes parts.	–
	Make Label	Creates label.	–
	Make LED	Creates LED.	–
	Display Grid Line	Shows/hides grid line.	–
	Load...	Loads GUI output file.	–
	Save...	Saves GUI output file.	–

1.17 Coverage Window

This window is used to measure the coverage (C0 coverage) of each function in the currently downloaded C language program. There are two types of coverage windows: a coverage window that allows you to reference the start/end addresses and the coverage of each function and a coverage source window that allows you to reference for each source line whether the target program has been executed or not.

1.17.1 Structure of Coverage Window

1.17.1.1 Structure of Coverage Window

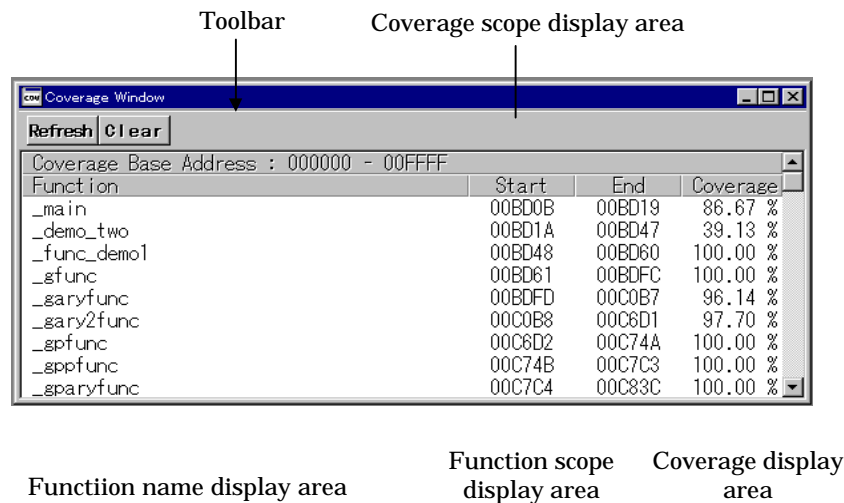

- When the target program is executed using a GO or STEP command, the display in the Coverage column changes to '--'. To update the display, press the Refresh button on the toolbar (or select [Option] → [Refresh] from the menu).
- The coverage source window that allows you to reference for each source line whether the target program has been executed or not can be opened by double-clicking on any desired line in the Function column.
- The function scope display area can be turned on or off by selecting or deselecting [Option] → [Layout] → [Address Area] from the menu.

1.17.1.2 Structure of Coverage Source Window

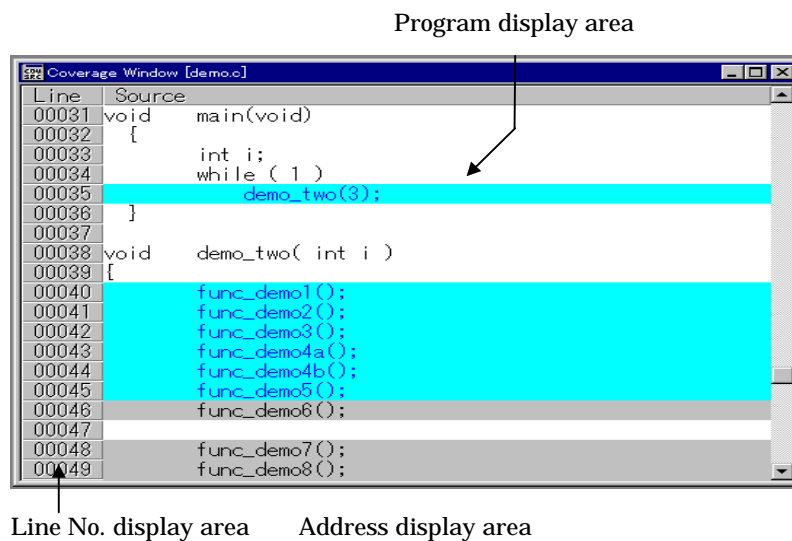

- The lines that have already been executed are displayed in blue. The lines for which there is no line debug information available (e.g., comment lines) are displayed in white. Unexecuted lines are displayed in gray.
- The executed/non-executed information in the program display area is automatically updated when the program has stopped. If you want to see some other function, double-click on the desired function in the coverage window. (The window can be scrolled through functions providing that they exist in the same source file.)
- The line No. display area and address display area can be displayed or hidden by selecting or canceling [Option] → [Layout] → [Line Area] and [Option] → [Layout] → [Address Area]. Note that, by default, the address display area is hidden.

1.17.2 Coverage Window Toolbar

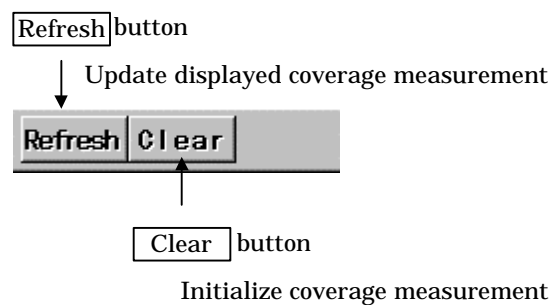

1.17.3 Extended Menus in the Coverage Window

1.17.3.1 Extended Menus in the Coverage Window

When the Coverage Window is active in the PD38SIM main display area, the [Option] menu contains the following items:

Menu	Menu options	Function	Shortcut keys
Option	Font...	Change font.	–
	Refresh	Update displayed coverage measurement results.	–
	Clear	Initialize coverage measurement results.	–
	File	Input/output coverage measurement result files.	–
	Save...	Save coverage measurement result file.	–
	Load...	Load coverage measurement result file.	–
	Layout	Set layout.	–
	Address Area	Turn on/off address area.	–

1.17.3.2 Extended Menus in the Coverage Source Window

When the Coverage Source Window is active in the PD38SIM main display area, the [Option] menu contains the following items:

Menu	Menu options	Function	Shortcut keys
Option	Font...	Change font.	–
	TAB...	Set source file display tabs.	–
	Layout	Set layout.	–
	Line Area	Turn on/off line No. area.	–
	Address Area	Turn on/off address area.	–

1.18 S/W Break Point Setting Dialog Box

The S/W Break Point Setting dialog box allows you to set software break points. Software breaks stop the execution of instructions immediately before the specified break point. You can also enable and disable each of those break points.

1.18.1 Structure of S/W Break Point Setting Dialog Box

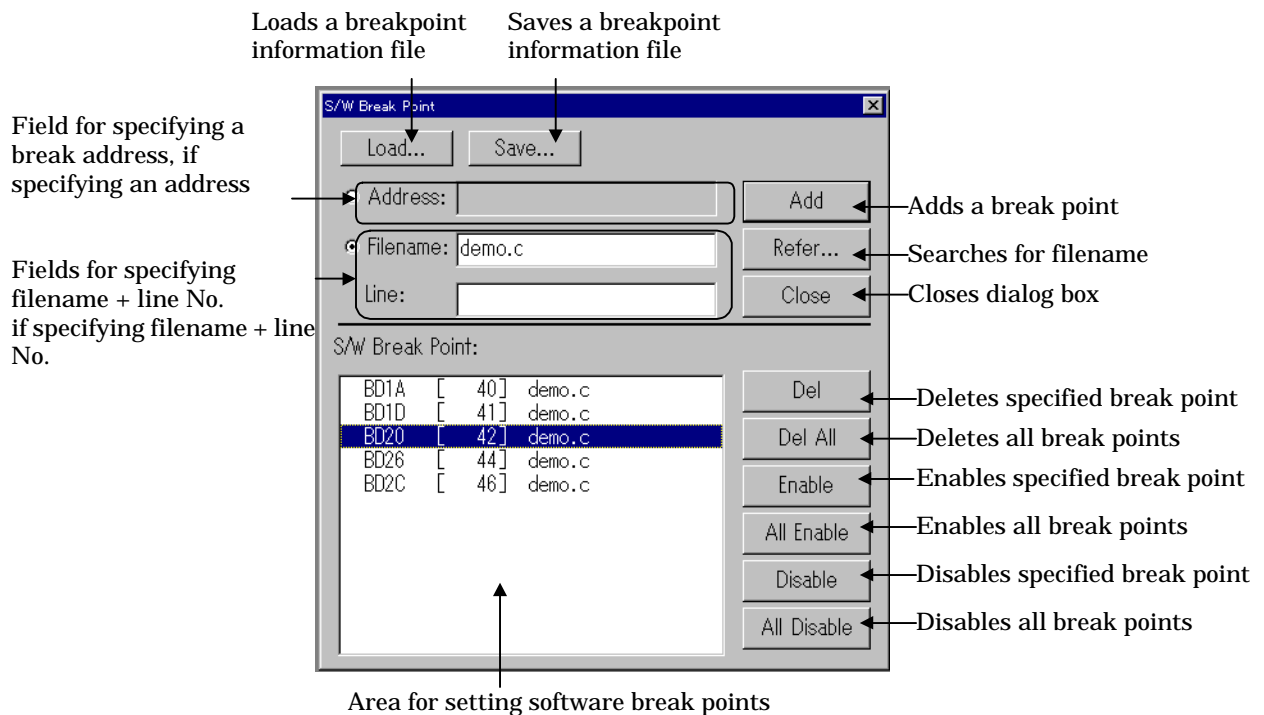

- You can set up to 64 software break points in PD38SIM.
- If you have set multiple software breakpoints, program execution stops when any one software break address is encountered (OR conditions).
- You can continue to set software breakpoints until you click the <Close> button to close the S/W BreakPoint setting dialog box.
- You can clear, enable or disable software breakpoints selected by clicking in the software breakpoint display area. You can also enable and disable software breakpoints by double-clicking on them.

1.18.2 Entries in List of Software Break Points

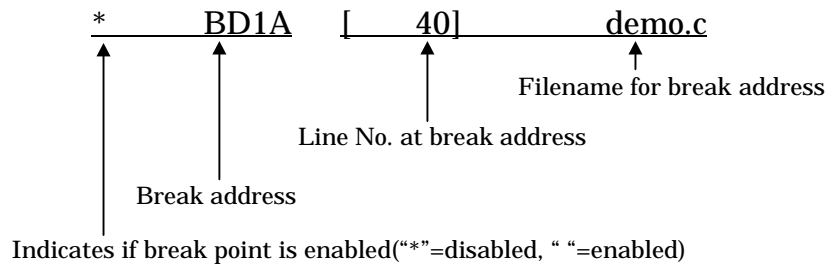

- If there is no source line, etc., for the address, only the address is displayed.

1.19 H/W Break Point Setting Dialog Box

The H/W Break Point Setting dialog box allows you to set hardware break points. Hardware breaks are effected when data is written to or read from memory, or an instruction is fetched from memory.

1.19.1 Structure of H/W Break Point Setting Dialog Box

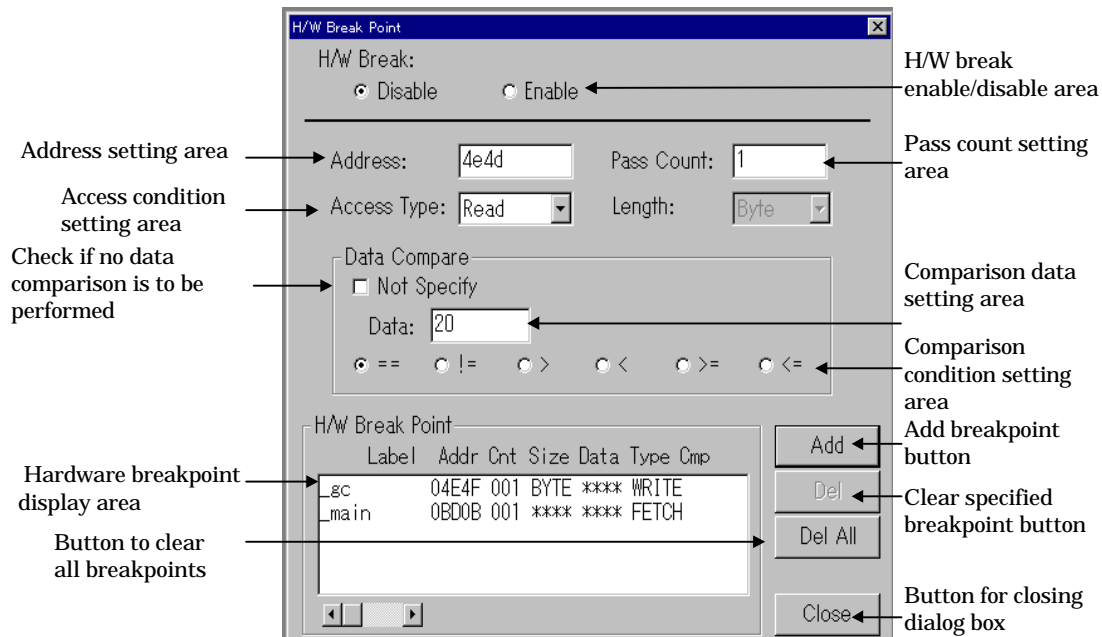

- You can set up to 64 hardware break points in PD38SIM.
- If you have set multiple hardware breakpoints, program execution stops when any one hardware break address is encountered (OR conditions).
- You can continue to set hardware breakpoints until you click the <Close> button to close the H/W BreakPoint setting dialog box.
- You can clear hardware breakpoints selected by clicking in the hardware breakpoint display area.

1.19.2 Entries in List of Hardware Break Points

<u>gc</u>	<u>04E4F</u>	<u>001</u>	<u>BYTE</u>	<u>40</u>	<u>READ</u>	<u>≥</u>
↑	↑	↑	↑	↑	↑	↑
Label for break address	Break address	Pass count	Data size	Comparison data	Access condition	Comparison condition

[MEMO]

Basic Operation

1 Loading and Displaying the Target Program

1.1 Downloading

To download the target program, select the following from the PD38SIM Window:

[File] -> [Download] -> [Load module...]

The File Selection dialog box opens. Select the target program from the File Selection dialog box. The file to be downloaded is in the Intel HEX format file (called an HEX file) or the IEEE-695 absolute file format (called an 695 file). HEX files have the filename extension ".HEX", 695 files have the filename extension ".695". When the HEX file is specified for the down-loading file, After the HEX file is down-loaded, the symbol file of this name is read. The file attribute of the symbol file is ". sym".

You can also press Shift+F1 to open the File Selection dialog box for downloading files.

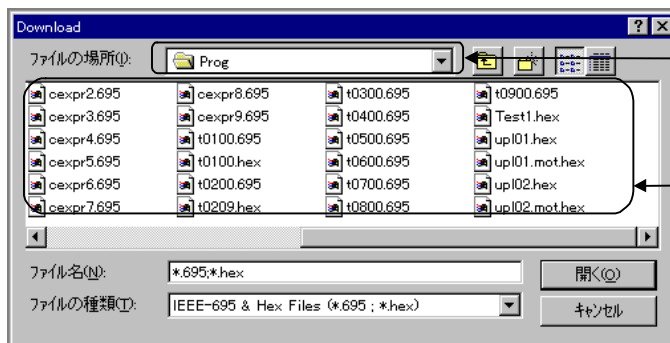

1. Find the directory.

2. Double-click the file name.

Note:

If you download the file but the Program and Source Window does not switch to Source Program mode, the file may not contain source line information. Check the options that you specified when compiling, assembling, and linking.

To download only machine language data

To download only machine language data, select the following from the PD38SIM Window menu:

[File] -> [Download] -> [Memory Image...]

The File Selection dialog box opens. Select the HEX file or the 695 file, then download the machine language data.

To download only symbol data

To download only symbol data, select the following from the PD38SIM Window menu:

[File] -> [Download] -> [Symbol...]

Select 695 file or sym file from the file Selection dialog box, then download the symbol data. When you download only symbol data, only the symbol data from the file 695 is read.

To reload a file...

When downloading a previously downloaded file again, PD38SIM allows you to download it without having to specify its file name. To reload a file, choose the PD38SIM window menus.

[File] -> [Reload]

The file is reloaded when these menus are selected.

When using IAR C compiler ICC740...

It is necessary to make the IEEE-695 absolute format file specifying the option when compile and linking. Please refer to the release note of PD38SIM for details.

1.2 To Reload the recent downloaded file

The recent downloaded files (maximum files of 4) are listed in the PD38SIM Window menu [File].

To reload the file, select the file name listed.

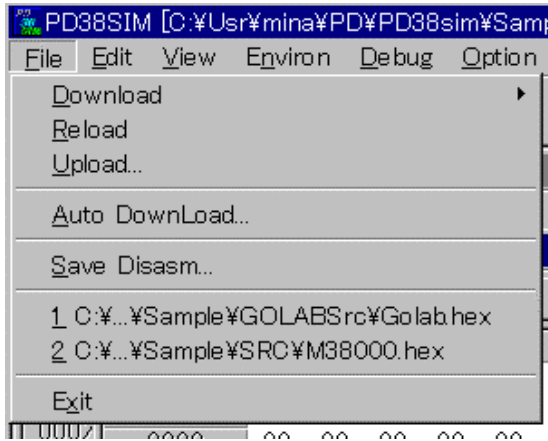

Note:

If the length of the file name with path is more than 25 characters, the display of the upper directory is abbreviated.

1.3 To download the target program automatically when updated

If the target program is updated when a command executing the target program, it can be downloaded automatically.

To select the PD38SIM Window menu [File] -> [AutoDownLoad...], the AutoDownLoad dialog box open. You can specify this function in this dialog box.

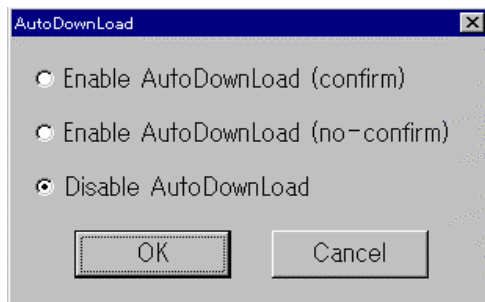

- Enable AutoDownLoad (confirm)
Downloading automatically with confirmation when the target program is updated.
- Enable AutoDownLoad (no-confirm)
Downloading automatically without confirmation when the target program is updated.
- Disable AutoDownLoad
Not downloading automatically even if the target program is updated.

1.4 Changing Program Display Position Immediately After Downloading

When you download a target program in PD38SIM, The Program Window displays the source program at the position of the program counter after the target program has been reset. If there is no source line data at this program counter position (the startup program, for example, has no source line data), the program is displayed in disassemble mode.

If, after downloading a target program, you want to automatically display a source program such as the "main" function, you must first specify the name of that function. From the PD38SIM Window menu, select

[Environ] -> [StartUp...]

to open the StartUp Dialog box. Specify the name of the function to be displayed.

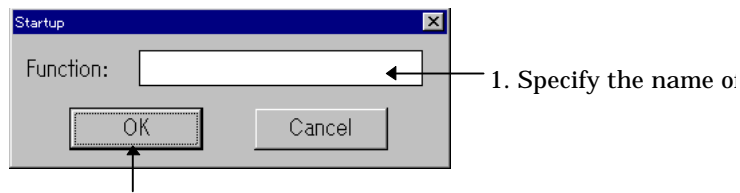

2. Click the "OK" button.

Even when you display the function specified in the StartUp dialog box in the Program Window, the program counter remains at the same value it held immediately after downloading. To advance the program counter to the function you specified in the StartUp dialog box, perform "Come" execution. See Section 2.4, "Program Execution to Specified Location" in the Basic Operation for details.

Note:

This setting is ignored if there is source line data at the position of the program counter immediately after downloading.

1.5 Uploading

From the PD38SIM Window menu, select

[File] -> [Upload...]

to open the Upload dialog box. Enter the upload area and the name of the file to be saved. You can specify files in the Intel HEX format. To save a file in the Intel HEX format, specify the ".hex" attribute. If you specify an existing filename, that file is overwritten.

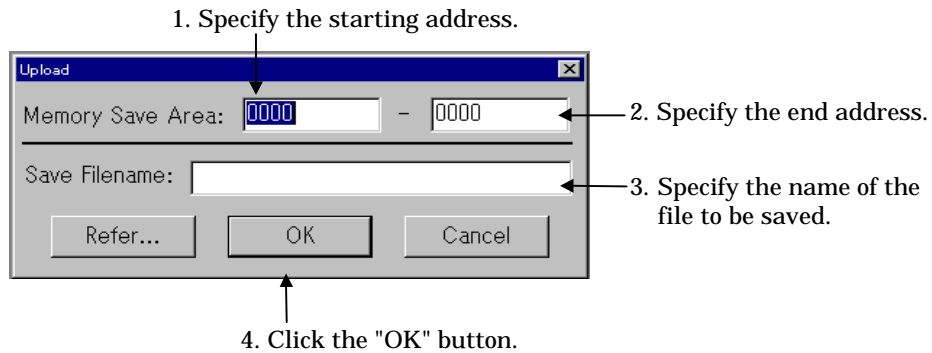

1.6 Saving Results of Disassembly

From the PD38SIM Window menu, select

[File] -> [Save Disasm...]

to open the Save Disasm dialog box. Enter the area to be saved and the filename. You can specify any filename and attribute. If you specify an existing filename, that file is overwritten.

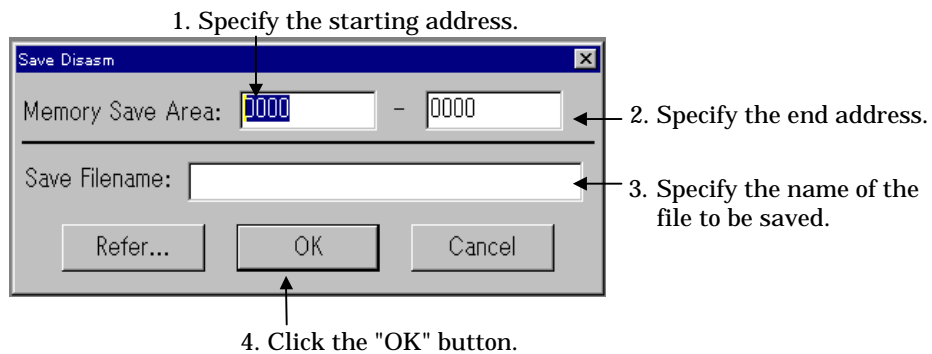

1.7 Continuing to Display a Selected Program Position

The Program Window always displays the target program at the position of the program counter and you cannot, therefore, choose to always display the same position. You can do so, however, in the Source Window. To open the Source Window, select the following from the PD38SIM Window menu:

[Window] -> [Source Window]

1.8 Changing the Program Display Position

You can display the source program in the Program Window and in the Source Window. To change the display position of the Program (or Source) Window, click on the "View" button in the toolbar of the Program (or Source) Window to open the Disp Area dialog box. You can only change the display position in the active window.



Click the "View" button to open the Disp Area dialog box.

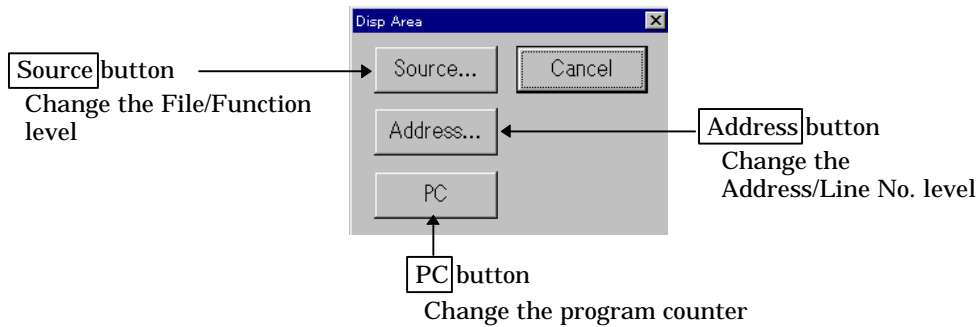

If no debugging information has been read in, no changes can be made at the file or function level, or at the line No. level. Further, if the Program (or Source) Window is in disassemble display mode, no changes can be made at the line No. level.

Changing the display position at the file/function level

Click the "Source" button in the Disp Area dialog box to open the Source dialog box. (The "Source" button cannot be clicked if no debugging information has been read in.) The Source dialog box shows the file structure of the downloaded target program plus data on functions. Click the name of the file and the function name to be changed.

1. Select the file name.

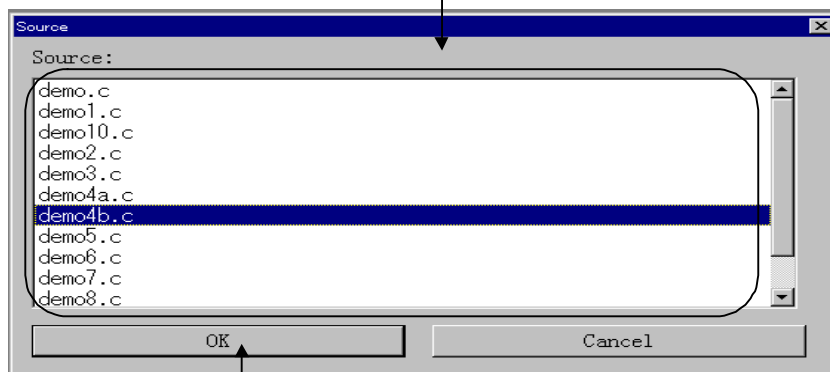

3. Click the "OK" button.

To open the Source dialog box, select the following from the PD38SIM Window menu:
 [Option] -> [View] -> [Source]

You can also double-click the line No. display area of the Program (Source) Window to open the Source dialog box.

Changing the display position at the address level

When the Program (Source) Window is in disassemble display mode, click the "Address" button from the Disp Area dialog box. Click the "Address" button to open the Disp Address dialog box.

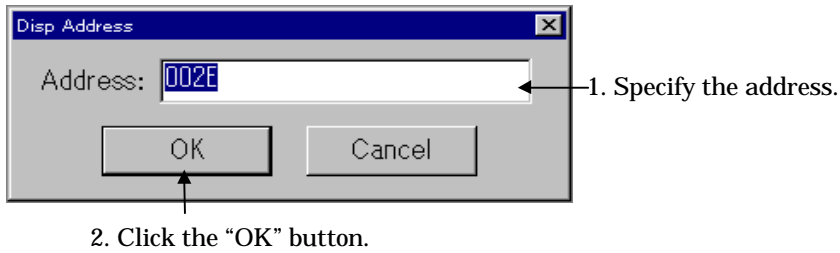

When the Program (Source) Window is in source display mode, or in mixed display mode, the Address dialog box (see below) is open. Click the Address button in the Address dialog box to enter the new address.

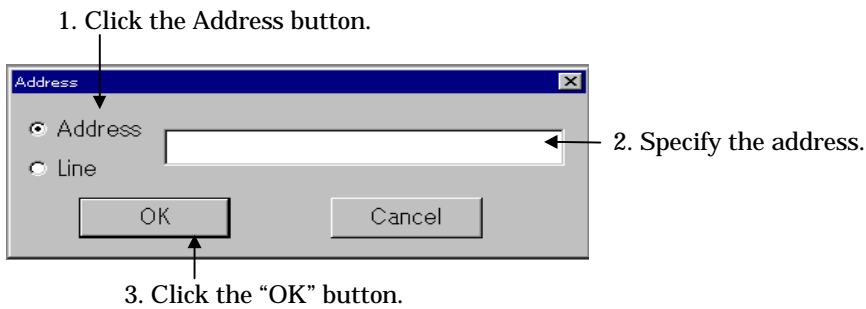

To open the Disp Address dialog box, select the following from the PD38SIM Window menu:

[Option] -> [View] -> [Address...]

You can also double-click the address display area of the Program (Source) Window to open the Disp Address dialog box.

Changing the display position at the line No. level

When the Program (Source) Window is in source display mode, click the "Address" button from the Disp Area dialog box. Click the "Address" button to open the Address dialog box. Click the Line button in the Address dialog box to enter the new line No.

1. Click the Line button.

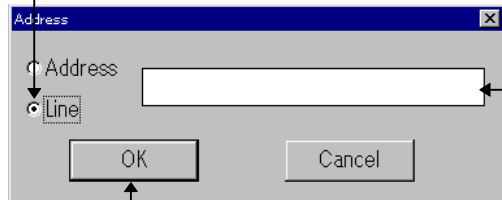

2. Specify the line No.

3. Click the "OK" button.

To open the Address dialog box, select the following from the PD38SIM Window menu:
 [Option] -> [View] -> [Address...]

You can also double-click the address display area of the Program (Source) Window to open the Address dialog box.

Changing the position of the program counter

Click the "PC" button in the Disp Area dialog box. When you click the "PC" button, the display position changes to the position of the program counter. Change the position of the program counter, select the following from the PD38SIM Window:

[Option] -> [View] -> [Program Counter]

1.9 Checking Source Programs in Other Directories

You can specify the search path for source files. This is helpful when the source files for target programs are stored in multiple subdirectories or not in the current directory. This function allows you to check these source files and set software breakpoints, etc., from the Program (or Source) Window. To open the Path dialog box and set the search path, select the following from the PD38SIM Window menu:

[Environ] -> [Path...]

To add a search path, click the "Add" button in the Path dialog box. The File Selection dialog box opens. Use the mouse to select the name of the file to be checked.

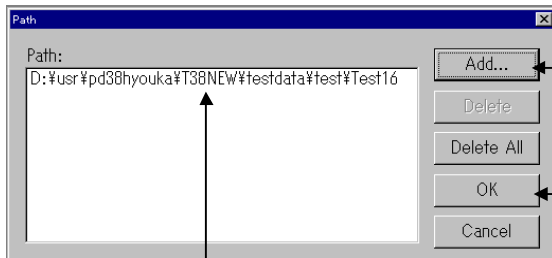

1. Click the "Add" button.

2. Specify the search path in the File Selection dialog box.

3. Click the "OK" button.

To delete a search path

Open the Path dialog box, then carry out the following:

1. Click the search path to be deleted.

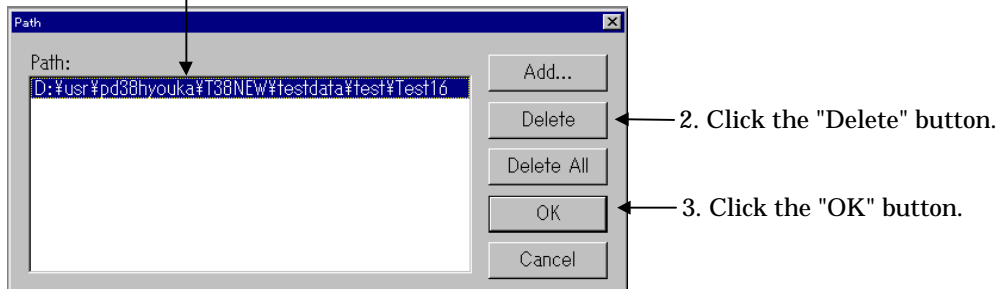

* Click "Delete All" to delete all search paths.

1.10 Mixing Source and Disassemble Displays

Click the "MIX" button on the Program (or Source) Window toolbar to simultaneously display both the source file and the results of disassembly. You can also select the following from the PD38SIM Window menu:

[Option] -> [Mode] -> [MIX Mode]

The display mode changes only in the active window.

The Program Window automatically switches to MIX display mode when the position of the program counter when the target program stops in the area output in the source line information and does not match the starting address of the source line.

To return to source program display from MIX display mode

Click the "SRC" button on the Program (or Source) Window toolbar. You can also select the following from the PD38SIM Window:

[Option] -> [Mode] -> [Source Mode]

Note:

If the macro definitions include a program counter value, the yellow line indicating the PC value may not be displayed.

1.11 Displaying the Results of Disassembling

To display the results of disassembling, click the "DIS" button on the Program (or Source) Window toolbar. You can also select the following from the PD38SIM Window menu:

[Option] -> [Mode] -> [Disasm Mode]

The display mode can only be changed in the active window.

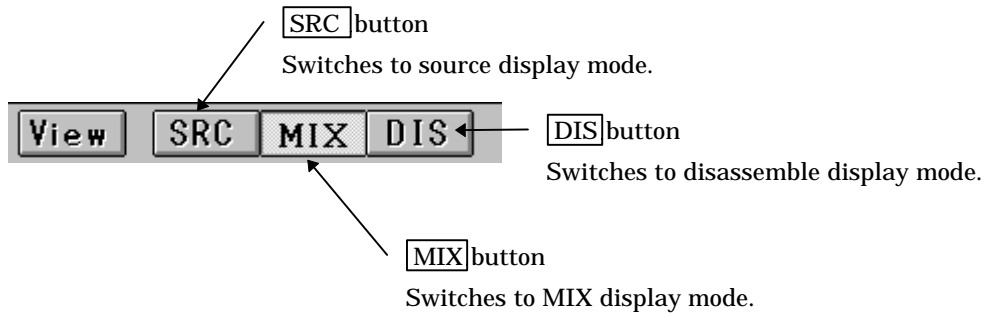

If, when the target program stops, the program counter is in an area with no source line data, the Program Window automatically switches to disassemble display mode.

To revert from disassemble display to source program display mode

Click the "SRC" button on the Program (or Source) Window toolbar.

You can also switch to source program display mode by selecting the following from the PD38SIM Window menu:

[Option] -> [Mode] -> [Source Mode]

To revert from disassemble display to MIX display mode

Click the "MIX" button on the Program (or Source) Window toolbar.

You can also switch to source program display mode by selecting the following from the PD38SIM Window menu:

[Option] -> [Mode] -> [MIX Mode]

Note:

If there is no source line data in the first line in the program display area of the Program (or Source) Window, you cannot switch from disassemble display mode to source display mode or MIX mode (the "SRC" and "MIX" buttons are invalid). In this case, use the vertical scrollbar or Up/Down cursor keys to move the starting address of the program display area to a position where there is source line data.

1.12 Changing Display Colors

To change display colors in the Program Window, when you select the menu [Option] -> [Color...], the Color Setup Dialog Box open.

Note that this setting have effect on all Source Windows.

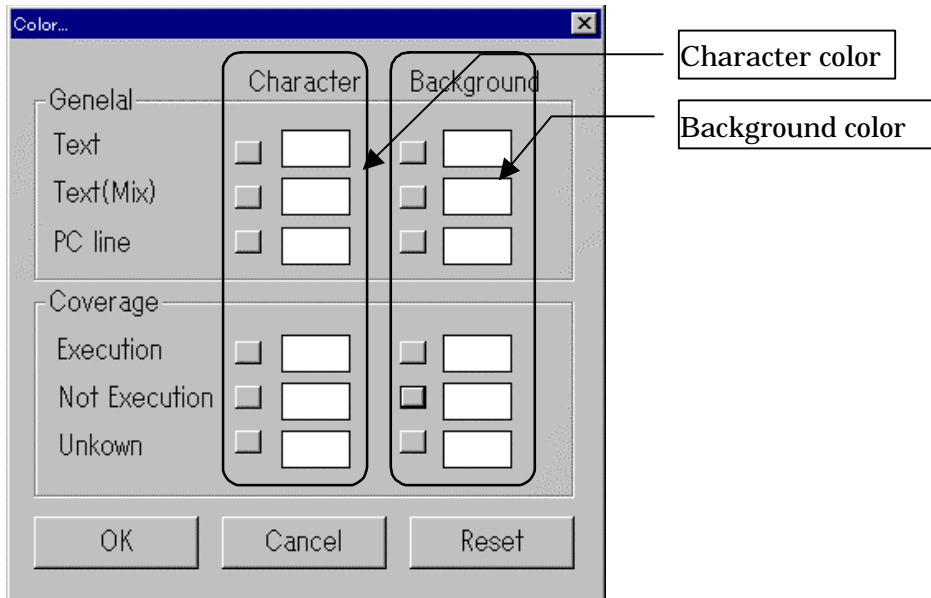

1.12.1 The functions of Color Setup Dialog Box

- Pushing the button to the left of each color box make the Color Setup Dialog Box open. You can change the display colors in this dialog box.
- Pushing the Reset button set the colors default.

2 Starting and Stopping Target Program Execution

2.1 Starting and Stopping

To start the target program

Click the "Go" button on the PD38SIM Window toolbar. You can also press the "F1" key.



Click the "Go" button.

You can also start the target program by selecting the following from the PD38SIM Window menu:

[Debug] -> [Go]

The target program runs until it reaches a breakpoint.

Free-running the target program

Selecting the PD38SIM Window menu [Debug] -> [GoFree] make the target program executed with software break points and hardware break points disabled.

To stop the target program

Click the "Stop" button on the PD38SIM Window toolbar.



Click the "Stop" button.

You can also stop the target program by selecting the following from the PD38SIM Window menu:

[Debug] -> [Stop]

Note:

If, when the target program stops, the program counter is in an area with no source line data, the Program Window automatically switches to disassemble display mode.

To start the target program from a specific address

Select the following from the PD38SIM Window menu:
 [Debug]-> [Go]-> [Go Option...]
 The Go dialog box opens. Enter the starting address.

To check if the target program is running

The current execution status is displayed at the right end of the status bar in the PD38SIM Window.

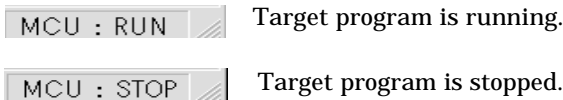

2.2 Step Execution

Click the "Step" button on the PD38SIM Window toolbar. Or press F3.



When the Program Window is in source program mode, each line of the source program is executed, step by step. When the Program Window is in disassemble mode, each instruction is executed, step by step.

You can also start step execution by selecting the following from the PD38SIM Window menu:

[Debug] -> [Step] -> [Step]

To execute subroutines as single instructions in step mode

Executing subroutines as single instructions in step mode is called as over-step execution. Click the "Over" button on the PD38SIM Window toolbar. Or press F4.



You can also start over-step execution by selecting the following from the PD38SIM Window menu:

[Debug] -> [Step] -> [Over]

To specify the time of steps

Select the following from the PD38SIM Window menu:

[Debug] -> [Step] -> [Step Option...]

(For over-step execution, select [Debug] -> [Over] -> [Over Option...].)

Specify the time of steps in the displayed Step (or Over) dialog box.

To stop step execution

Click the "Stop" button on the toolbar. You can also stop step execution by selecting the following from the PD38SIM Window menu:

[Debug] -> [Stop]

This also applies to over-step execution.

2.3 Returning from Current to Calling Routine

Click the "Return" button on the PD38SIM Window toolbar (called as Return execution). You can also press F5.



Click the "Return" button.

You can also return to a calling routine by selecting the following from the PD38SIM Window menu:

[Debug] -> [Return]

To stop return execution

Click the "Stop" button on the toolbar. You can also stop return execution by selecting the following from the PD38SIM Window menu:

[Debug] -> [Stop]

2.4 Program Execution to Specified Location

To run the target program to the specified position (known as Come Execution), first click the line at which you want the program to stop in the program display area of the Program (Source) Window to specify the cursor position. Note, however, that Come Execution cannot be carried out if the cursor is positioned on a line in which no software breakpoint can be set (comment lines, and data definition lines, etc.).

Line	Address	BRK	Source
00001			.section P
00002			.org \$e000
00003			
00004	E000	-	start:
00005	E000	-	nop
00006	E001	-	nop
00007	E002	-	nop
00008	E003	-	nop
00009	E004	-	loop:
00010	E004	-	jmp loop
00011			

Cursor position set by clicking the mouse.

To start Come execution, click the "Come" button on the PD38SIM Window toolbar. You can also press F2.



Click the "Come" button.

You can also start Come execution by selecting the following from the PD38SIM Window menu:

[Debug] -> [Come]

To stop come execution

Click the "Stop" button on the toolbar. You can also stop Come execution by selecting the following from the PD38SIM Window menu:

[Debug] -> [Stop]

2.5 Resetting the Program

To reset the target program, click the "Reset" button on the PD38SIM Window toolbar. You can also press F8.



Click the "Reset" button.

You can also reset the target program by selecting the following from the PD38SIM Window menu:

[Debug] -> [Reset]

3 Checking and Setting Register Data and Memory Contents

3.1 Checking the Contents of Registers

Open the Register Window to check the contents of the registers. The Register Window, which lists the CPU registers, is opened from the PD38SIM Window menu by selecting the following:

[Basic Window] -> [Register Window]

See Section 1.4, "Register Window" in the Window Functions for details of the Register Window.

To Change the Display Radix of the Register Value

The display radix can be changed for each register. This is done with the following procedure.

1. Click the right mouse button on the Name of the register whose display radix you want to change.
2. Select the radix you want displayed from the menu.

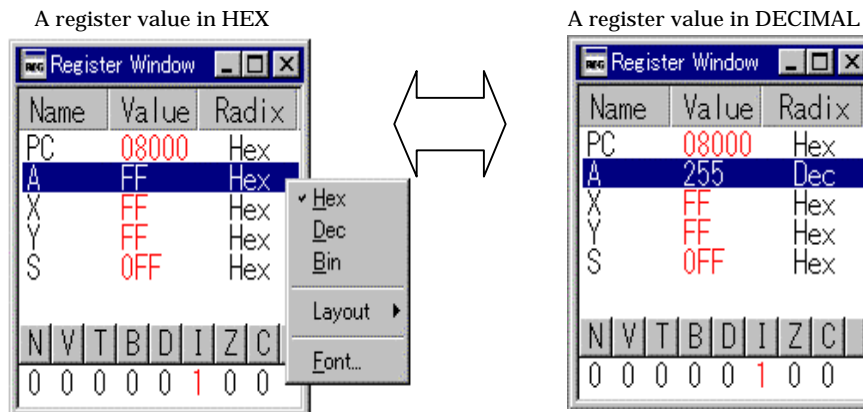

3.2 Changing the Contents of Registers

To Change the Register Value

Register contents can be changed with the following procedure.

1. Either double-click on the register line you want to change or select the line and press the Enter key.
2. A dialog box for setting the register value and radix will open up, therefore input the new value and radix.

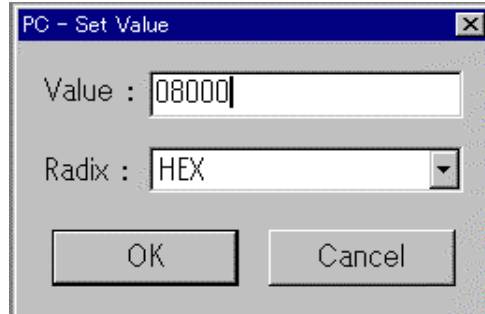

To change the values of flags

- When flag window is open
 Click on the button of the flag you want to change.
 The flag value will change ever time it is clicked on.
 However, for flags like IPL whose size is larger than 1 bit, a dialog box for setting the register value will open up.
- When the flag window is not open
 Flag values can be changed in the same way as register values. Either click on the line where "FLG" is displayed or select the line and press the Enter key.

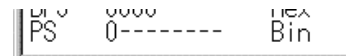
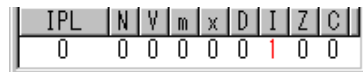

To Change Register Window Layout

- Changing window size
 When window size is changed, the contents of the window are laid out to fit the new window size.

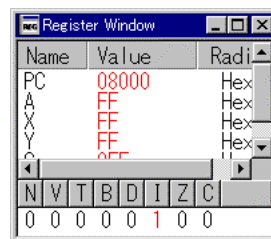
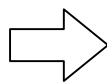
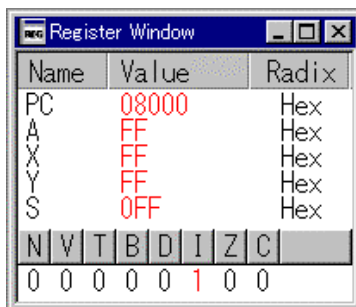

1. A scroll bar is Added where necessary.
1. Flags are assigned depending on window and font size.

- To hide the radix item

With the Register Window active, either select [Option] >> [Layout] >> [Hide Radix] from the menus or click the right mouse button on the register window list area and select [Layout] >> [Hide Radix].

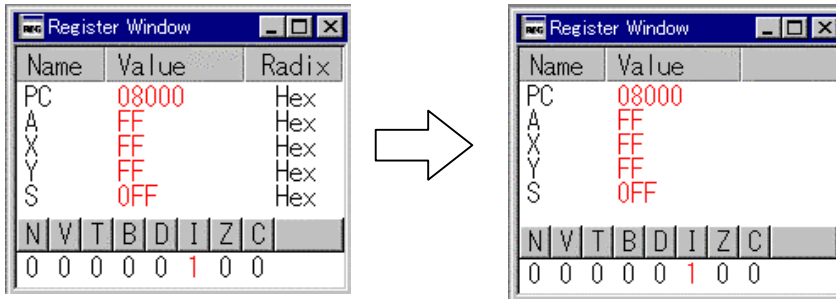

- To hide the flag item

With the Register Window active, either select [Option] >> [Layout] >> [Hide FLAGS] from the menus or click the right mouse button on the FLG line and select [Layout] >> [Hide FLAGS].

The radix in the flag item will not change.

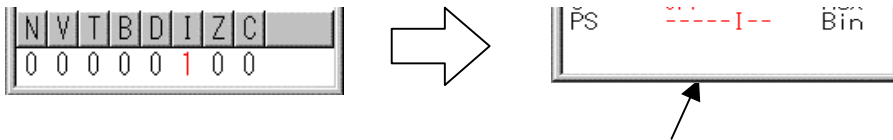

Flag register item. The name of the currently set flag is displayed.

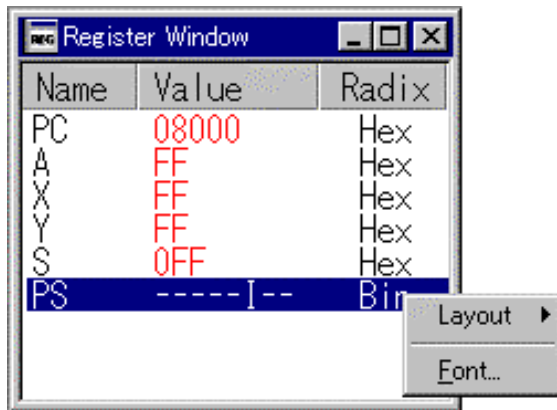

The radix item does not appear in the pop-up menu displayed over the register window.

- To adjust column width

The width of each of the Name, Value and Radix columns in the register window can be adjusted. Drag the separator to do so. Also, double-clicking on the separator will automatically adjust the width to the length of the longest character string.

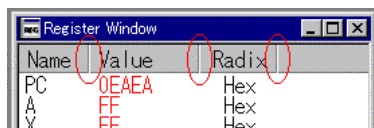

3.3 Checking Changes in RAM During Target Program Execution

Use the RAM monitor function to check changes in the contents of memory while the target program is running. Check the changes in memory during execution using the RAM Monitor Window. To open the RAM Monitor Window, select the following from the PD38SIM Window menu:

[Basic Window] -> [RAM Monitor Window]

See Section 1.7, "RAM Monitor Window" in the Window Functions for details of the RAM Monitor Window.

To change the RAM monitor area

PD38SIM has a 1KB RAM monitor area, which by default is mapped to 0 to 3FF₁₆. If you want to check another area, you must change the RAM monitor area. To do so, click the **Area** button on the toolbar in the RAM Monitor Window, or make sure the RAM Monitor Window is active, then select the following from the PD38SIM Window menu to open the RAM Monitor Area dialog box:

[Option] -> [RAM Monitor Area...]

Enter the starting address of the RAM monitor area.

The RAM monitor area is also changed when you double-click the address display area in the RAM monitor window to change the display starting address. In this case, if the specified display starting address is not within the current RAM monitor area, a confirmation dialog box is displayed asking whether or not to adjust the RAM monitor area. Click the **OK** button to adjust the area.

To change the sampling period

The contents of memory displayed in the RAM Monitor Window are automatically updated at regular intervals. The default sampling period is 100[ms]. To change the sampling period, make sure the RAM Monitor Window is active, then select the following from the PD38SIM Window menu to open the Sampling Period dialog box.

[Option] -> [Sampling Period...]

However, depending on operating conditions, updating may be slower than specified.

3.4 Checking the Value at a Specified Address

Use the watch function to check the value at a specified address. Check the value at the specified address in the ASM Watch Window. The address is called as the watch point. To open the ASM Watch Window, select the following from the PD38SIM Window menu:

[Basic Window] -> [ASM Watch Window]

If the specified watch point is within the RAM monitor area, changes during program execution can be monitored from the ASM Watch Window.

See Section 1.8, "ASM Watch Window" in the Window Functions for details of the ASM Watch Window.

To register a watch point

Click the **Add** button in the menu bar in the ASM Watch Window to open the Add dialog box. Input the address to monitor.

You can register the watch points also in the pop-up menu [Add ASM Watch] of the Program Window.

1. Click the "Add" button to open the following dialog box.

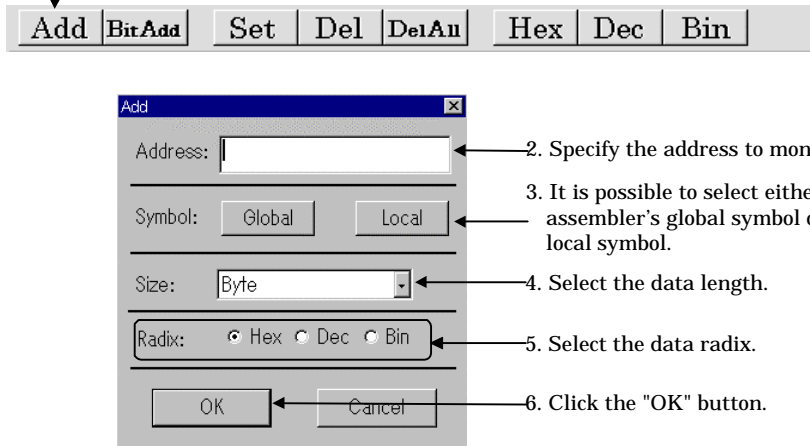

The registered watchpoint is added at the current cursor position in the ASM Watch Window. The cursor position is indicated by a red mark in the address display area and data display area. You can move the cursor by clicking on either area or using the **Up** and **Down** keys.

To register a specific bit as a watch point

Click the **BitAdd** button in the menu bar in the ASM Watch Window to open the BitAdd dialog box. Input the bit symbol or the address and bit No. to monitor.

You can register the watch points also in the pop-up menu [BitAdd ASM Watch] of the Program Window.

1. Click the "BitAdd" button to open the following dialog box.

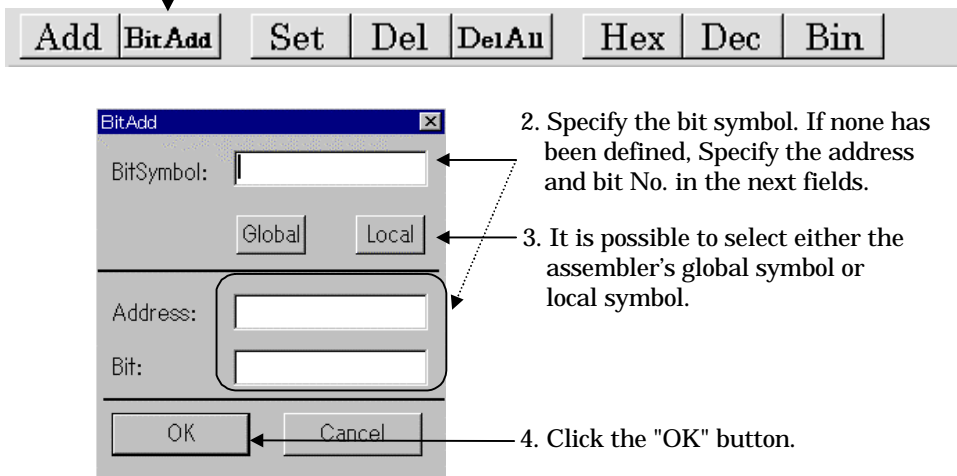

To change the value at a specified address

Select the watch point to change in the ASM Watch Window, then click the **Set** button on the toolbar of the ASM Watch Window.

2. Click the **Set** button.

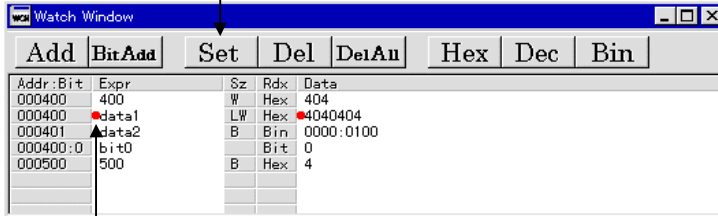

1. Click the watch point to be changed.

The Set dialog box opens. Enter the new value.

To delete a watch point

Select the watch point to be deleted in the ASM Watch Window, then click the **Del** button on the toolbar of the ASM Watch Window.

2. Click the **Del** button.

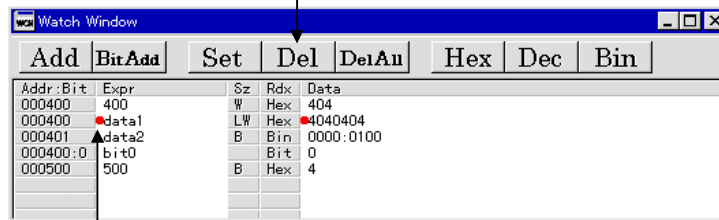

1. Click the watch point to be deleted.

* To delete all watch points, click the **DelAll** button.

You can also click the watch point to be deleted, then press the Delete key.

To change the memory display format

You can change the radix in which data is displayed to select the watch point to be changed in the ASM Watch Window, then clicking **Hex**, **Dec**, or **Bin** in the toolbar of the ASM Watch Window.

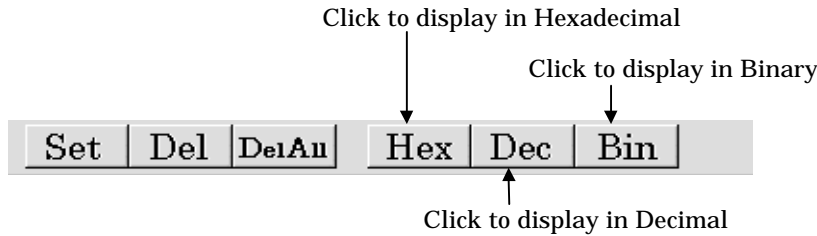

You can also double-click the radix display area in the ASM Watch Window.

3.5 To switch scope

To set a Scope, open the Scope Setting dialog box by selecting [Scope...] under [Debug] from the menu in the PD38SIM Window.

Selecting the object listed in this dialog box make change the scope to the object

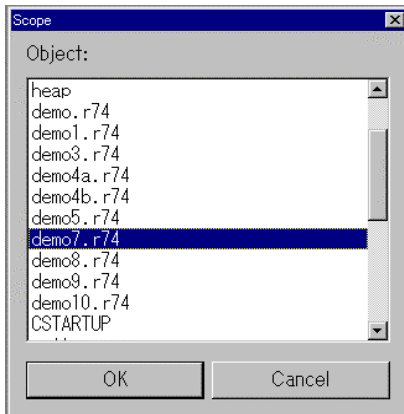

3.6 Setting Data at a Specified Address

You can use the Memory Window or Dump Window to set data at a specified address. To use the Memory Window, select the following from the PD38SIM Window menu:

[Basic Window] -> [Memory Window]

To use the Dump Window, select the following from the PD38SIM Window menu:

[Basic Window] -> [Dump Window]

See Section 1.5, "Memory Window" in the Window Functions for details of the Memory Window, and Section 1.6, "Dump Window" in the Window Functions for details of the Dump Window.

To change data at a specified address

With the Memory Window or Dump Window active, select the following from the PD38SIM Window menu:

[Option] -> [Debug] -> [Set...]

When the Set dialog box opens, enter the address to be changed and the new data.

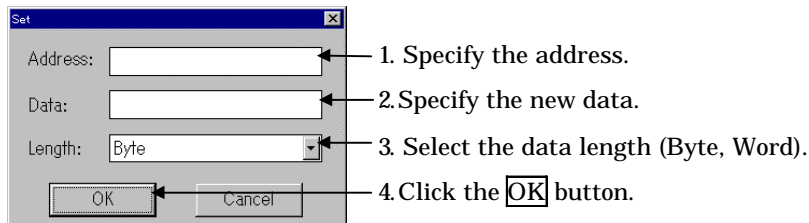

You can also double-click the data display area in the Memory Window or Dump Window to open the Set dialog box.

To fill a specified area with data

With the Memory Window or Dump Window active, select the following from the PD38SIM Window menu:

[Option] -> [Debug] -> [Fill...]

When the Fill dialog box opens, enter the area to be filled and the fill data.

When the Fill Dialog Box open after selecting the area by mouse in the Memory Window or in the Dump Window, the start and end address of the area are set in this Dialog box.

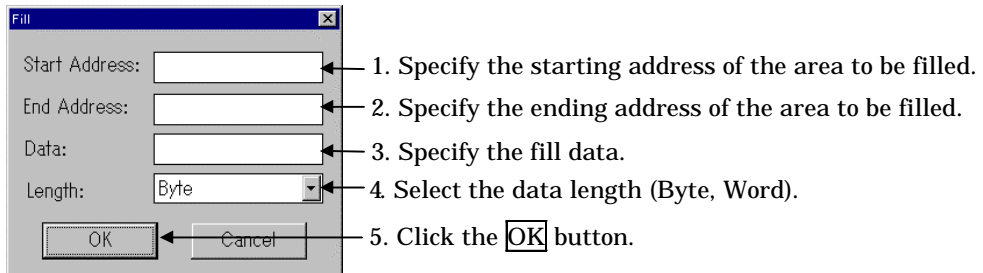

To move the contents of a specified area to another area

With the Memory Window or Dump Window active, select the following from the PD38SIM Window menu:

[Option] -> [Debug] -> [Move...]

When the Move dialog box opens, enter the starting and ending addresses of the source area and the starting address of the destination area.

When the Move Dialog Box open after selecting the area by mouse in the Memory Window or in the Dump Window, the start and end address of the area are set in this Dialog box.

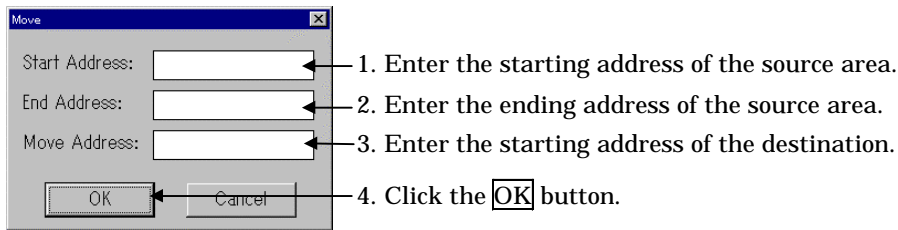

3.7 Updating the Memory Display

When you execute a command (setting, filling, moving memory, stopping execution, or step execution, etc.) that changes the contents of memory, the memory display in the Memory Window and Dump Window is automatically updated. However, if an area such as I/O, which is changed without any relationship to MCU execution, is displayed, there may be a discrepancy between the data displayed and the actual contents of memory.

In this case, you can display the latest contents of memory in the Memory Window by clicking the **Refresh** button on the toolbar in the Memory Window, or making the Memory Window the active window, then selecting the following from the PD38SIM Window menu:

[Option] -> [View] -> [Refresh]

To display the latest contents of memory in the Dump Window, click the **Refresh** button on the toolbar in the Dump Window, or make the Dump Window the active window, then select the following from the PD38SIM Window menu:

[Option] -> [View] -> [Refresh]

3.8 To change the acquisition mode of the memory

The Memory Window and the Dump Window have internal cache storing the 512 Kbytes memory data for quick displaying.

When the window is resized or scrolled within this 512 Kbytes memory area, the memory of the area is not accessed.

To disable this caching, click the Cache button or select the menu [Option] -> [CacheOn].

When the memory cache is disabled, the memory out of the display is not accessed and if the display area changes by scrolling and resizing the memory is accessed.

4 Software Breaks

Use a software break to break target program execution at a specified line (address). Use the S/W Break Point Setting dialog box to set a software break point. When you set a software break, execution of the target program stops immediately before the software break point.

- You can set up to 64 software break points.
- If you set multiple software break points, the target program stops as soon as execution reaches any of the software break addresses.

4.1 Opening the S/W Break Point Setting Dialog Box

Click the "SW" button on the PD38SIM Window toolbar. Press function key F7 to open the software breakpoint setting dialog box.



Click the "SW" button.

You can also open the S/W Break Point Setting dialog box by selecting the following from the PD38SIM Window menu:

[Debug] -> [Break Point] -> [S/W Break Point...]

See Section 1.18, "S/W Break Point Setting Dialog Box" in the Introduction for the structure of the S/W Break Point Setting dialog box.

4.2 Setting a Break Point

To specify an address as a break point

In the S/W Break Point Setting dialog box, specify an address or label in the Address field, as follows:

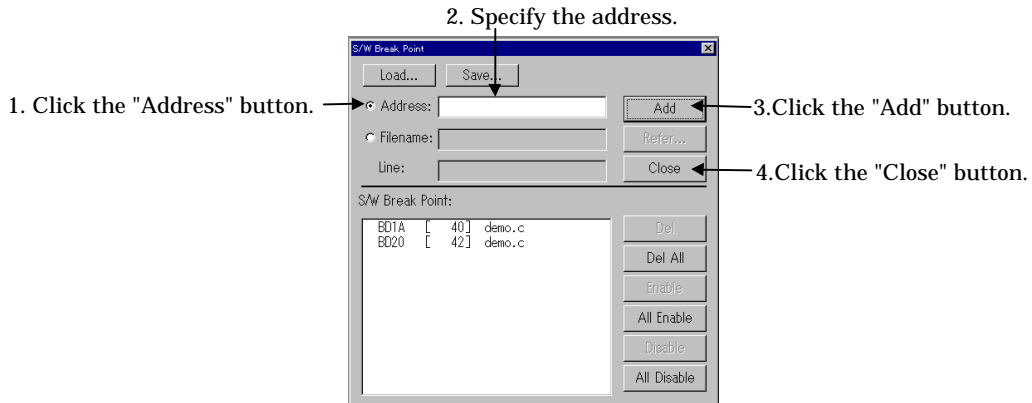

To specify a line No. as a break point

In the S/W Break Point Setting dialog box, specify a filename and a line No, as follows:

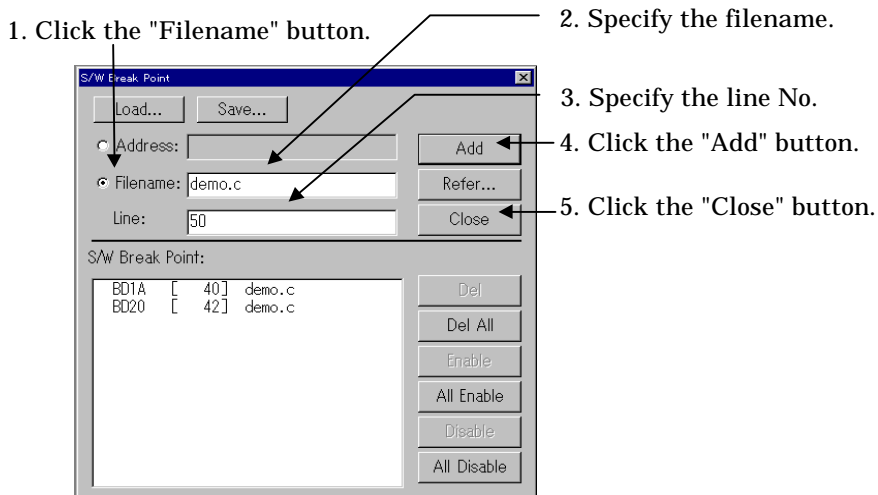

4.3 Deleting a Break Point

In the S/W Break Point Setting dialog box, delete the break point as follows:

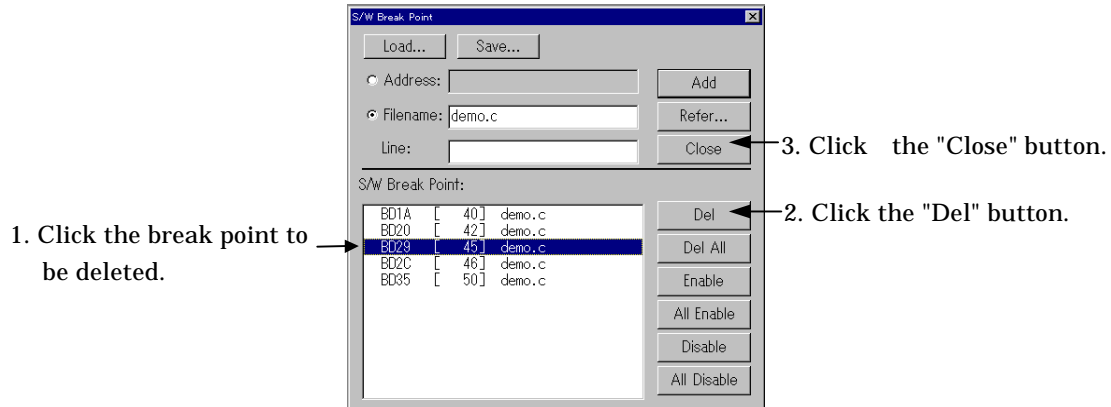

* Click "Del All" to delete all break points.

You can also click the breakpoint to be deleted, then press the Delete key.

4.4 Temporarily Disabling Break Points

In the S/W Break Point Setting dialog box, disable the break point as follows:

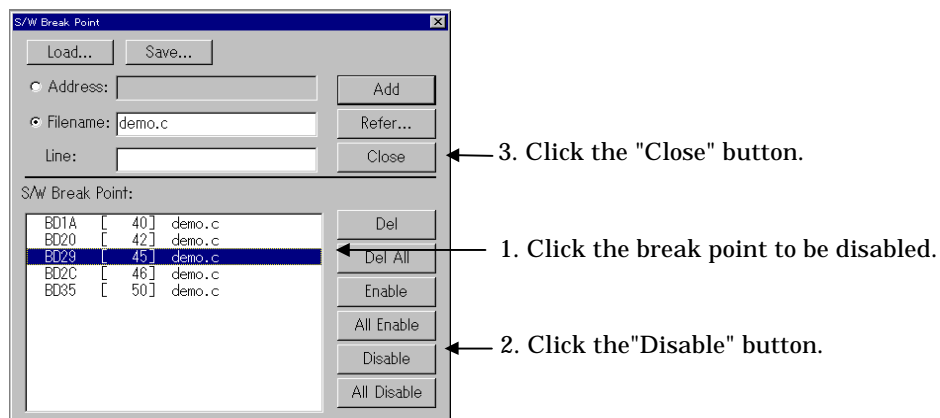

* Click "All Disable" to disable all break points.

You can also double-click the breakpoint to be disabled. (An asterisk (*) is displayed).

4.5 Temporarily Enabling Break Points

In the S/W Break Point Setting dialog box, enable the break point as follows:

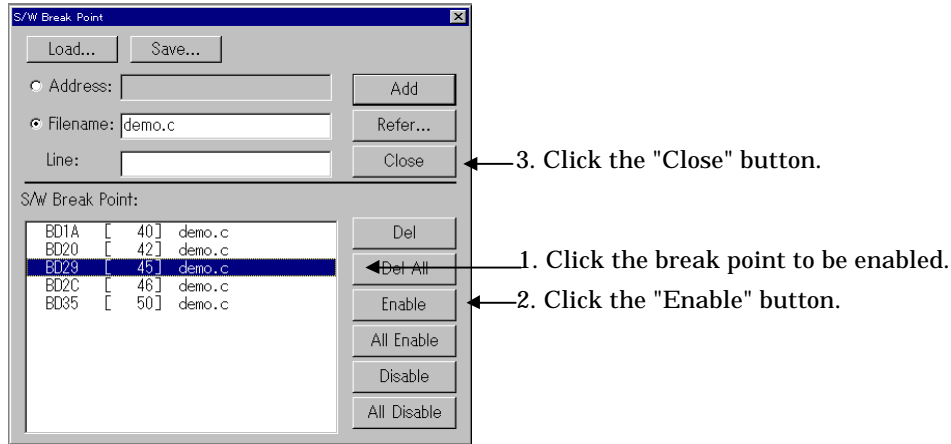

* Click "All Enable" to enable all break points.

You can also double-click the breakpoint to be enabled. (An asterisk (*) is deleted).

4.6 Setting a Break Point from Program (Source) Window

You can also set break points in the Program or Source Window. To do so, double-click the break point setting display area (BRK column) (indicated by "-") for the line in which you want to set the break.

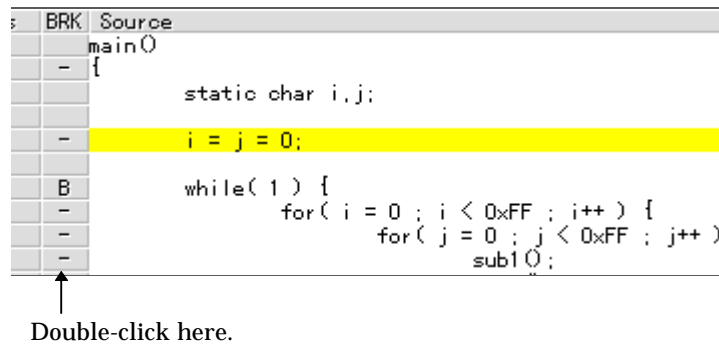

Lines in which a software break point have been set are marked by a "B" in place of the "-" in the break point setting display area (BRK column). You can delete the break point by double-clicking again in the BRK column.

4.7 Setting Breakpoints from the Toolbar

You can set breakpoints from the toolbar in the PD38SIM Window. In the Program (Source) Window, click the program display area of the line in which you want to set the break (lines for which "-" is displayed in the corresponding breakpoint display area).

To set the breakpoint, click the "Break" button in the PD38SIM Window toolbar.



Click the "Break" button.

You can also set a breakpoint by selecting the following from the PD38SIM Window menu:
[Debug] -> [Break Point] -> [Break]

The mark on the lines set as software breakpoints changes from "-" to "B" in the breakpoint display area of the window. You can cancel a software breakpoint by again clicking the line indicated by "B" then clicking the "Break" button.

4.8 Saving Breakpoints

Click the "Save" button in the S/W Break Point setting dialog box to open the file selection dialog box. Specify the name of the file in which to save the breakpoints. The default filename suffix, if not specified, is ".brk".

4.9 Loading Breakpoints

Click the "Load" button in the S/W Break Point setting dialog box to open the file selection dialog box and load breakpoints from a saved file. Specify the name of the file to be loaded. The breakpoints loaded from the file are added to any currently set breakpoints. If the number of software breakpoints exceeds 64, the excess are ignored.

5 Hardware Breaks

Use hardware breaks to break target program execution when memory is accessed. Use the H/W Break Point Setting dialog box to set a hardware break point. Hardware breaks are effected when data is written to or read from memory, or an instruction is fetched.

- You can set up to 64 hardware break points.
- If you set multiple hardware break points, the target program stops as soon as execution reaches any of the hardware break addresses.

5.1 Opening the H/W Break Point Setting Dialog Box

Click the "HW" button on the PD38SIM Window toolbar. Press function key Shift + F7 to open the hardware breakpoint setting dialog box.



Click the "HW" button.

You can also open the H/W Break Point Setting dialog box by selecting the following from the PD38SIM Window menu:

[Debug] -> [Break Point] -> [H/W Break Point...]

See Section 1.19, "H/W Break Point Setting Dialog Box" in the Introduction for the structure of the S/W Break Point Setting dialog box.

5.2 Setting Hardware Breakpoints

To break when the instruction at a specified address is executed

The following example shows how to break when the instruction at address BD0B₁₆ is executed. Make the following settings in the H/W Break Point setting dialog box.

The screenshot shows the 'H/W Break Point' dialog box with the following settings and annotations:

- 1. Select "Enable".** The 'Enable' radio button is selected under the 'H/W Break:' section.
- 2. Enter address "BD0B".** The 'Address:' text box contains 'bd0b'.
- 3. Select "Fetch".** The 'Access Type:' dropdown menu is set to 'Fetch'.
- 4. Click the "Add" button.** The 'Add' button is highlighted.
- 5. Click the "Close" button.** The 'Close' button is highlighted.

The dialog box also includes a 'Pass Count' field set to '1', a 'Length' dropdown set to 'Byte', a 'Data Compare' section with 'Not Specify' checked and 'Data:' set to '0', and a table for existing breakpoints.

Label	Addr	Cnt	Size	Data	Type	Cmp

To break when data is read from the specified address

The following example shows how to break when data has been read twice from address 4E4F₁₆. Make the following settings in the H/W Break Point setting dialog box.

The screenshot shows the 'H/W Break Point' dialog box with the following settings and annotations:

- 1. Select "Enable".** The 'Enable' radio button is selected under the 'H/W Break:' section.
- 2. Enter address "4E4F".** The 'Address:' text box contains '4e4f'.
- 3. Select "Read".** The 'Access Type:' dropdown menu is set to 'Read'.
- 4. Enter a pass count of "2".** The 'Pass Count:' text box contains '2'.
- 5. Click the "Add" button.** The 'Add' button is highlighted.
- 6. Click the "Close" button.** The 'Close' button is highlighted.

The dialog box also includes a 'Length' dropdown set to 'Byte', a 'Data Compare' section with 'Not Specify' checked and 'Data:' set to '0', and a table for existing breakpoints.

Label	Addr	Cnt	Size	Data	Type	Cmp
_main	0BD0B	001	****	****	FETCH	

To break when the specified data is read from the specified address

The following example shows how to break when the specified data (12₁₆) has been read twice from address 4E4D₁₆. Make the following settings in the H/W Break Point setting dialog box.

The screenshot shows the 'H/W Break Point' dialog box with the following settings and annotations:

- H/W Break:** Enable (1. Select "Enable").
- Address:** 4e4d (2. Enter address "4E4D").
- Access Type:** Read (3. Select "Read").
- Pass Count:** 2 (4. Enter a pass count of "2").
- Data Compare:** Not Specify (5. Deselect "Not Specify").
- Data:** 12 (6. Enter data "12").
- Comparison:** == (7. Select "==").
- Buttons:** Add (8. Click the "Add" button), Del, Del All, Close (9. Click the "Close" button).

Label	Addr	Cnt	Size	Data	Type	Cmp
_gc	04E4F	002	BYTE	****	READ	
_main	0BD0B	001	****	****	FETCH	

To break when data is written to the specified address

The following example shows how to break when the specified data (12₁₆) has been written five times to address 4E4B₁₆. Make the following settings in the H/W Break Point setting dialog box.

The screenshot shows the 'H/W Break Point' dialog box with the following settings and annotations:

- H/W Break:** Enable (1. Select "Enable").
- Address:** 4e4b (2. Enter address "4E4B").
- Access Type:** Write (3. Select "Write").
- Pass Count:** 5 (4. Enter a pass count of "5").
- Data Compare:** Not Specify (5. Deselect "Not Specify").
- Data:** 12 (6. Enter data "12").
- Comparison:** == (7. Select "==").
- Buttons:** Add (8. Click the "Add" button), Del, Del All, Close (9. Click the "Close" button).

Label	Addr	Cnt	Size	Data	Type	Cmp
_w	04E4D	002	BYTE	0012	READ	==
_gc	04E4F	002	BYTE	****	READ	
_main	0BD0B	001	****	****	FETCH	

To break when the specified data or greater is written to the specified address

The following example shows how to break when the specified data (56₁₆) or greater is written to address 4E40₁₆. Make the following settings in the H/W Break Point setting dialog box.

The screenshot shows the 'H/W Break Point' dialog box with the following settings and annotations:

- 1. Select "Enable".** The 'Enable' radio button is selected.
- 2. Enter address "4E40".** The 'Address' field contains '4e40'.
- 3. Select "Write".** The 'Access Type' dropdown is set to 'Write'.
- 4. Deselect "Not Specify".** The 'Not Specify' checkbox under 'Data Compare' is unchecked.
- 5. Enter data "56".** The 'Data' field contains '56'.
- 6. Select ">=".** The '>=' comparison operator is selected in the 'Data Compare' section.
- 7. Click the "Add" button.** The 'Add' button is highlighted.
- 8. Click the "Close" button.** The 'Close' button is highlighted.

The 'H/W Break Point' table in the dialog box contains the following data:

Label	Addr	Cnt	Size	Data	Type	Cmp
_d	04E4B	005	BYTE	0012	WRITE	==
_w	04E4D	002	BYTE	0012	READ	==
_gc	04E4F	002	BYTE	****	READ	==
_main	0B00B	001	****	****	FETCH	==

To disable a hardware break

The following shows how to disable a hardware break. Make the following settings in the H/W Break Point dialog box.

The screenshot shows the 'H/W Break Point' dialog box with the following settings and annotations:

- 1. Select "Disable".** The 'Disable' radio button is selected.
- 2. Click the "Close" button.** The 'Close' button is highlighted.

The 'H/W Break Point' table in the dialog box contains the following data:

Label	Addr	Cnt	Size	Data	Type	Cmp
_d	04E40	001	BYTE	0056	WRITE	>=
_w	04E4B	005	BYTE	0012	WRITE	==
_gc	04E4D	002	BYTE	0012	READ	==
_main	04E4F	002	BYTE	****	READ	==
	0B00B	001	****	****	FETCH	==

5.3 Deleting a Hardware Breakpoint

Make the following settings in the H/W Break Point dialog box.

1. Click the breakpoint to be deleted.

2. Click the "Del" button.

3. Click the "Close" button.

Label	Addr	Cnt	Size	Data	Type	Cmp
_d	04E40	001	BYTE	0056	WRITE	>=
_w	04E4B	005	BYTE	0012	WRITE	=
sc	04E4F	002	BYTE	****	READ	=
_main	0BD0B	001	****	****	FETCH	

* Click the "Del All" button to delete all breakpoints.

You can also click the breakpoint to be deleted, then press the Delete key.

6 Checking C Variables

6.1 Checking C Variables

6.1.1 Checking C Variables in Source/Program display

The value of the C variable is displayed, when the mouse cursor stand still (about 0.5 seconds) on the strings of the variable in the Program display.

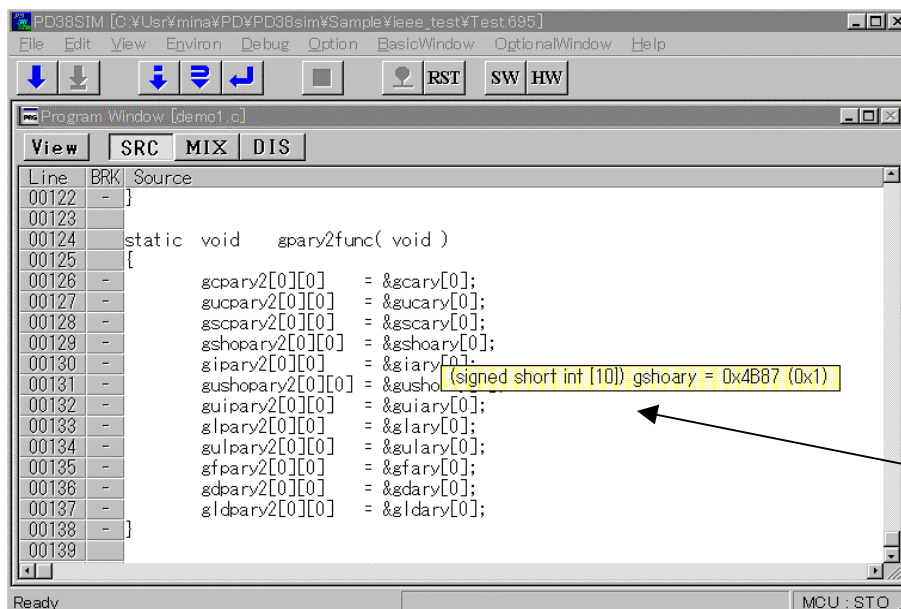

The value of the C variable is displayed

6.1.2 Checking C Variables in Cwatch display

PD38SIM has four windows for checking the C variables declared in the target program.

- Local Window:
- File Local Window:
- Global Window:
- C Watch Window:

The Local Window displays the values of variables that are valid only within a function. To open the Local Window, select the following from the PD38SIM Window menu:

[Basic Window] -> [C Watch Window] -> [Local Window]

The File Local Window displays the values of variables that are valid only within the file. To open the File Local Window, select the following from the PD38SIM Window menu:

[Basic Window] -> [C Watch Window] -> [File Local Window]

The Global Window displays the values of global variables. To open the Global Window, select the following from the PD38SIM Window menu:

[Basic Window] -> [C Watch Window] -> [Global Window]

The C Watch Window displays the values of any variables. To open the C Watch Window, select the following from the PD38SIM Window menu:

[Basic Window] -> [C Watch Window] -> [C Watch Window]

You cannot select the referenced C variables in the Local Window, File Local Window, or Global Window. The variables displayed in the respective windows change with the current position of execution of the target program.

- Local Window
The variables displayed change according to the function currently being executed.
- File Local Window
The variables displayed change according to the currently executing source file.
- Global Window
This lists the C global variables regardless of the execution position.
Use the C Watch Window to check C variables.

To register the C watch point

(Method 1: Registering a C Watch Point from the C Watch Window)

Click the "Add" button on the toolbar in the C Watch Window to open the Add dialog box, then enter the C language expression (C variables, expressions, etc.). To register a C expression as a pointer, click the "Add*" button on the toolbar in the C Watch Window. This registers the C expression as a C watch point.

1. Click the "Add" button to register the C watch point.



1. Click the "Add*" button to register the C watch point as a pointer.

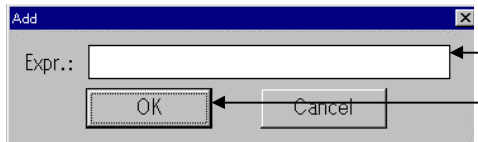

2. Specify the C expression.

3. Click the "OK" button.

(Method 2: Registering a C Watch Point from the Local, File Local, or Global Window)

You can register variables displayed in the Local Window, File Local Window, and Global Window as C watch points. Click the variable to be registered, then click the "Cwatch" button on the toolbar. To register the variable as a pointer, click the "Cwatch*" button.

2. Click the "Cwatch" button.

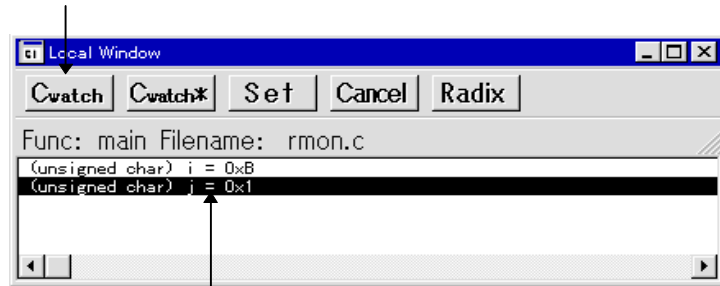

1. Click the C variable to be registered.

Note:

There is a possibility that compiler arranges a different variable in the same address for optimization.

6.2 To change the value of a C variable

You can change the values of C variables in the Local Window, File Local Window, Global Window, or C Watch Window. Click the variable to be changed, then click the "Set" button on the toolbar to open the Set dialog box. Enter the new value for the variable.

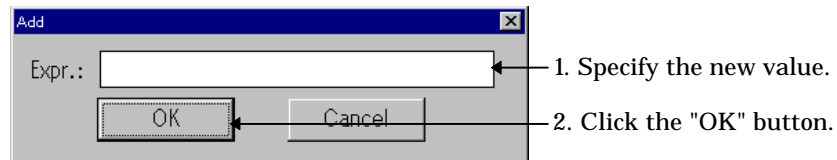

Note:

There is a possibility that compiler arranges a different variable in the same address for optimization.

7 Script Commands

7.1 Executing Script Commands

Script commands are executed from the Script Window. To open the Script Window, select the following from the PD38SIM Window menu:

[Basic Window] -> [Script Window]

Enter script commands in the Command input area in the Script window. Click the Command input area to locate the cursor in that field, then enter the script command. After executing the command, the results are output to the execution result display area.

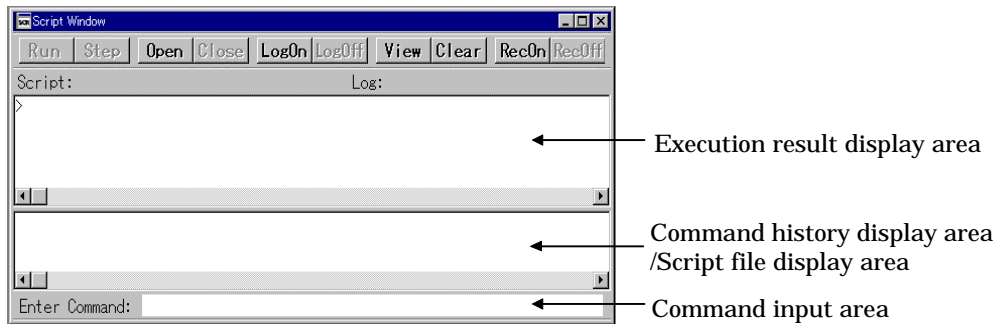

To re-execute a previously executed command

The history of command execution is displayed in the command history display area. Double-click the command you want to execute again.

To quit a script command that is executing

Click the STOP button, which is displayed only while the command is being executed.



7.2 Logging the Results of Executing Script Commands

Use the logging function to log the results of executing script commands. Before executing the script command, click the "LogOn" button on the toolbar of the Script Window.

Clicking the "LogOn" button opens the File Selection dialog box. Specify the name of the file to be saved. The default file attribute, if omitted, is ".log".



Click "LogOn" to start logging.

You can also select the following from the PD38SIM Window menu (when the Script Window is active):

[Option] -> [Log] -> [On...]

- If, after starting PD38SIM, you open and close a log file, then re-open it, the new data is appended to the data already in that file. However, if you re-open a log file that was created before starting PD38SIM, the contents of that file will be overwritten.
- The file list in the File Selection dialog box starts with files with the ".log" attribute. However, you can enter a full filename (including the attribute) directly into the filename input area to open a log file with an attribute other than ".log".
- You can nest log files up to 8 levels.

To quit logging the results of executing script commands

Click the "LogOff" button on the toolbar of the Script Window.



Click "LogOff" to stop logging.

You can also select the following from the PD38SIM Window menu (when the Script Window is active):

[Option] -> [Log] -> [Off]

- When log files are nested, output to the current log file stops, but output to the next higher-level log file resumes.

To save the results of executing script commands after execution

PD38SIM has a View Buffer that stores the results of executing the last 1000 lines of command results. To save the contents of the view buffer, click "View" on the toolbar of the Script Window.

Clicking "View" opens the File Selection dialog box. Specify the name of the file to be saved. The default file attribute, if omitted, is ".viv".



Click "View" to save the contents of the view buffer.

You can also select the following from the PD38SIM Window menu (when the Script Window is active):

[Option] -> [View] -> [Save...]

- When you specify an existing filename, the contents of the view buffer are appended to the existing file.
- The file list in the File Selection dialog box starts with files with the ".viv" attribute. However, you can enter a full filename (including the attribute) directly into the filename input area to open a view file with an attribute other than ".viv".

To clear the results of execution from the screen

Click the "Clear" button on the menu in the Script Window to clear the contents of the command display.

Note that the contents of the View buffer are cleared at the same time as the command display.



Click the "Clear" button to clear the command display.

You can also select the following from the PD38SIM Window menu (when the Script Window is active):

[Option] -> [View] -> [Clear]

To record the executed commands...

PD38SIM have the function recording the history of executed commands to a file. This function records not the result but only the executed commands, so the saved files can be used as the script files.

To record the executed commands, click the "RecOn" button in the Script Window toolbar.

Clicking "RecOn" opens the File Selection dialog box. Specify the name of the file to be saved. The default file attribute, if omitted, is ".scr".



Click "RecOn" to record the executed commands.

You can also select the following from the PD38SIM Window menu (when the Script Window is active):

[Option] -> [Record] -> [On...]

- The file list in the File Selection dialog box starts with files with the ".scr" attribute. However, you can enter a full filename (including the attribute) directly into the filename input area to open a view file with an attribute other than ".scr".

To stop recording the executed commands...

To stop recording the executed commands, click the "RecOff" button in the Script Window toolbar. Clicking the "RecOff" button make the commands saved file closed.



Click "RecOff" to stop recording the executed commands

You can also select the following from the PD38SIM Window menu (when the Script Window is active):

[Option] -> [Record] -> [Off...]

7.3 Executing Script Commands in Batch Mode

You can execute script commands in batches. To do so, use an editor to write the commands to be executed in a script file. Script files take the ".scr" attribute.

Script files are opened from the Script Window. Click the "Open" button on the Script Window toolbar.

When the file selection dialog box opens, select the script file to be executed.



Click the "Open" button to open a script file.

You can also select the following from the PD38SIM Window menu (when the Script Window is active):

[Option] -> [Script] -> [Open...]

- The file list in the File Selection dialog box starts with files with the ".scr" attribute. However, you can enter a full filename (including the attribute) directly into the filename input area to open a script file with an attribute other than ".scr".
- You can nest script files up to 5 levels.

When a script file is read in, the command history display in the Script Window changes into the script file display.

To execute the contents of the script file as a batch, click "Run" on the toolbar of the Script Window.

Batch execution starts and the script file is then closed after all the commands have been executed.



Click the "Run" button to execute all the commands in the script file in batch mode.

You can also select the following from the PD38SIM Window menu (when the Script Window is active):

[Option] -> [Script] -> [Run]

To stop execution of a script file

Click the STOP button displayed in the Running script dialog box.

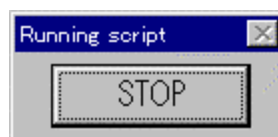

Execution of the script file stops before the next line.

To independently execute each command in a script file

Click the "Step" button on the Script Window toolbar (for step execution of the script). A command is executed each time you click the "Step" button.



Click the "Step" button for step execution of the script file.

You can also select the following from the PD38SIM Window menu (when the Script Window is active):

[Option] -> [Script] -> [Step]

To close a script file

Click the "Close" button on the Script Window toolbar.



Click the "Close" button to close the script file.

You can also close a script file by selecting the following (when the Script Window is active) from the PD38SIM Window menu:

[Option] -> [Script] -> [Close]

- If the script files are nested, the current script file is closed and the next higher level script file is opened.

To execute a script file on PD38SIM startup

Specify the name of the script file to be executed on startup in the Init dialog box which is displayed when you start PD38SIM.

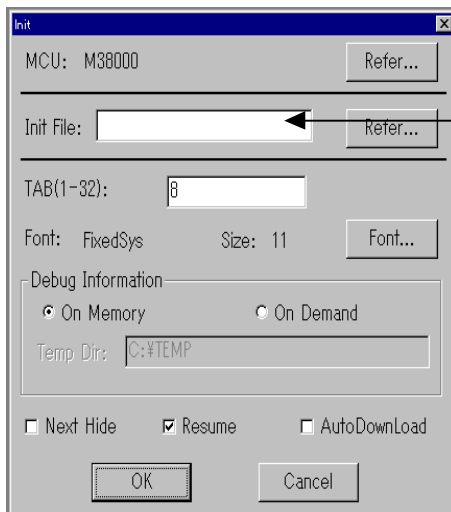

Specify the name of the script file to be executed on startup.

8 Exiting PD38SIM

8.1 Exiting PD38SIM

Select the following from the PD38SIM Window menu:

[File] -> [Exit]

A confirmation dialog box is displayed. Click OK to exit.

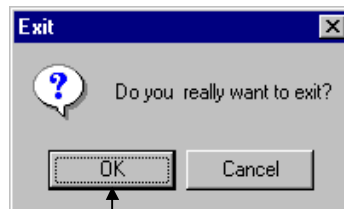

Click the "OK" button.

9 Miscellaneous

9.1 Line Assemble

There are two methods for line-assembling the source program, one using a line assemble dialog box and one using a script command.

9.1.1 Line Assembling from Dialog Box

Click on a position in the Program (Source) Window that you want to be line-assembled and choose menus [Option] -> [Line Assemble]. A line assemble dialog box like the one shown below will appear. (If you do not specify a position, input the desired address in this dialog box after it is open.)

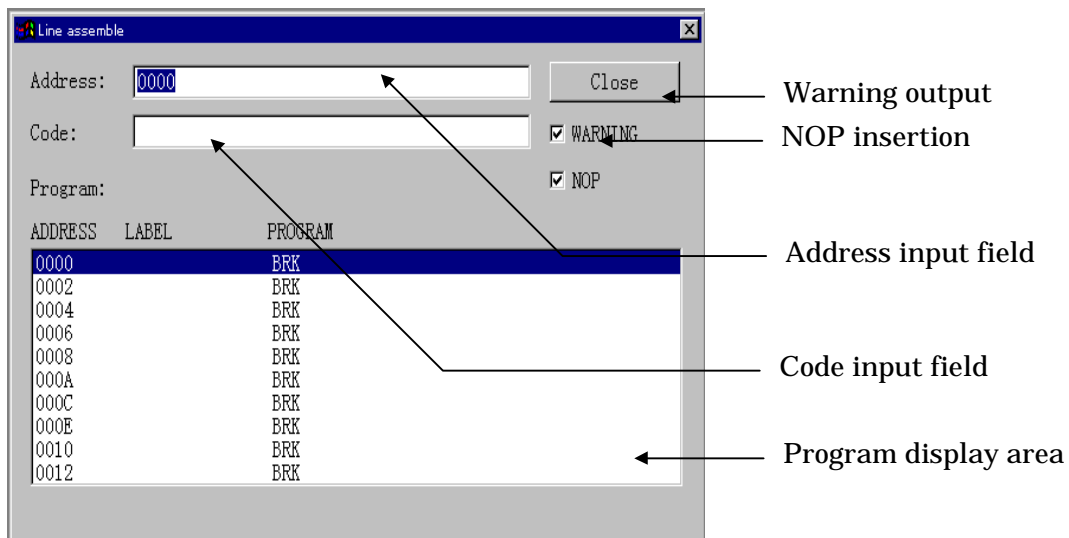

- Input the address you want to be line-assembled and the assemble instruction in the address input and the code input fields, then hit the return key. The line that is highlighted in the program display area of this dialog box is the address to be line-assembled.
 - If the number of instruction bytes input is fewer than that of instruction bytes before the change, insert a NOP instruction to make the number of bytes matched.
 - If the number of instruction bytes input is greater than that of instruction bytes before the change, a warning dialog box is opened. Press the OK button in this dialog box and the instruction you have input will be written to the program. If you press the Cancel button, PD38SIM abandons writing the instruction.
- If NOP insertion is turned off, no NOP instruction is inserted even when the number of instruction bytes input is fewer than that of instruction bytes before the change.

- If warning output is turned off, the instruction you have input is forcibly written to the program without bringing up a warning dialog box.
- By clicking on a line in the program display area of this dialog box, you can choose the line to be line-assembled.

9.1.2 Line Assembling from Assemble Command

Execute the assemble command (Assemble(A)) from the Script Window for line assembling. Specify the address for line assembling after the command.

>Assemble assemble-address

On execution of the Assemble command, the command input area of the Script Window changes to a mnemonic input field.

See Section 7.1, "Executing Script Commands" in the Basic Operation for details of how to use script commands. Enter the mnemonic for line assembling. The following shows the Script Window when waiting for a mnemonic to be input.

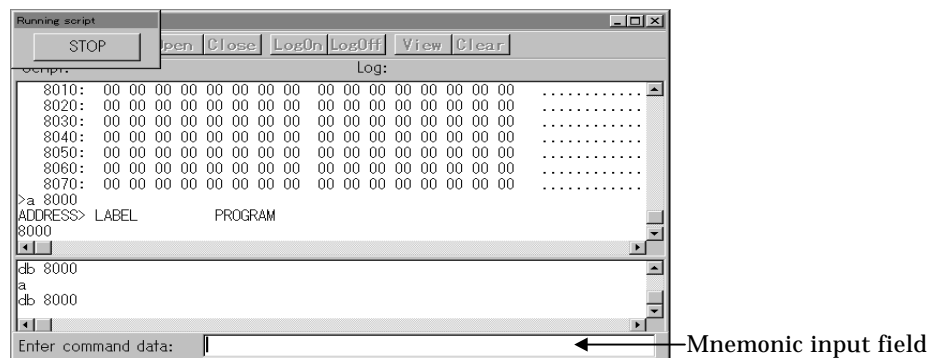

To exit the line assemble mode

Specify "Enter" in the mnemonic input area. The Script Window changes back to the status in which it waits for a script command to be entered.

9.2 Starting Up Make

The operation conventionally used to Make the target program after entering commands from the DOS window can be performed from PD38SIM.

The following shows the procedure for performing Make in PD38SIM.

1. Create a pif file.
 Follow the procedure below to create the pif file.
 - (a) Create a keyboard shortcut for command.com located in the Windows directory.
 - (b) For the keyboard shortcut thus created, assign a file name xxxx.pif (xxxx denotes a name specified by the user) and copies the file into the directory that contains makefile. This file becomes a pif file. Don't specify a suffix (.pif), when changing a file name.
 - (c) Open a property dialog box for this file and input the same command in the command line of this dialog box that was input from the DOS window.

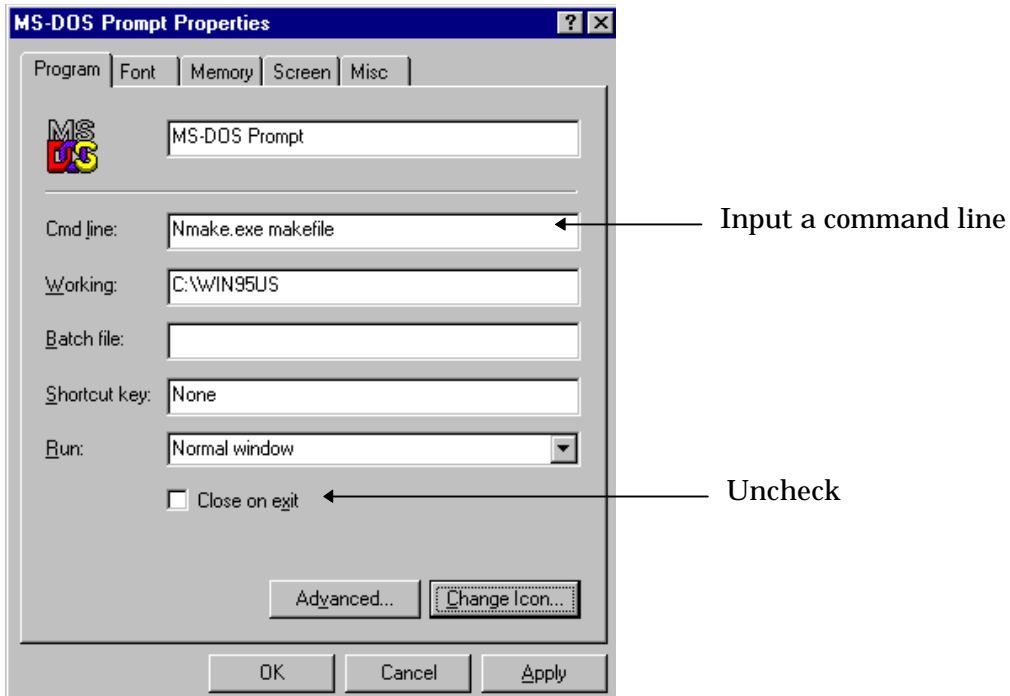

To open the property dialog box, choose [Property] from the menu that is displayed when you click the right mouse button after selecting a pif file using the explorer, etc.

- Register the pif file in PD38SIM.
Choose menus [Debug] -> [Entry] to bring up the dialog box shown below. Use this dialog box to register the pif file.

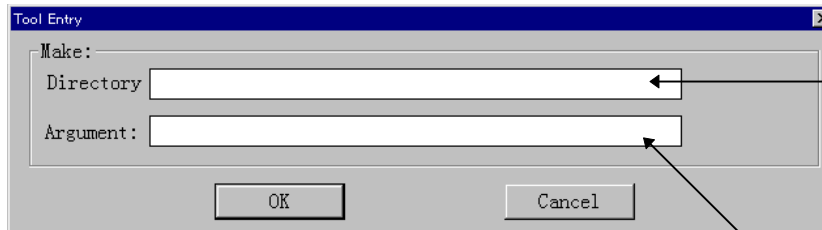

Input the directory to which the pif file has been copied.

Input a pif file name.

- Start up Make.
When you choose menus [Debug] -> [Make], the contents specified by the pif file are executed.

9.3 Searching for Character Strings in Target Program

You can search for character strings in the target program when the Program Window or Source Window is active. Make sure the target Program or Source Window is active, then select the following from the PD38SIM Window menu:

[Edit] -> [Find...]

The Find dialog box is displayed. Enter the search string, then click "Find Next" to start the search.

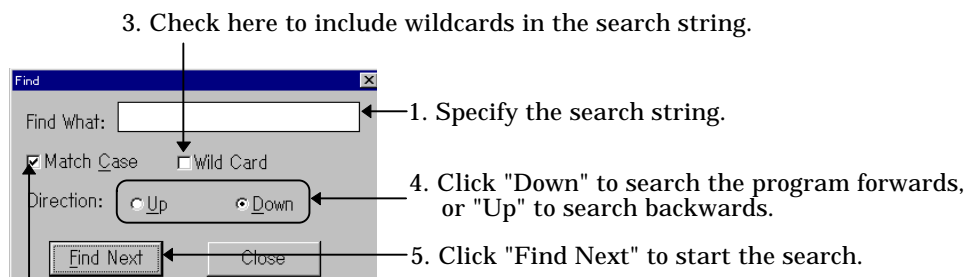

- Check here if you want to differentiate between uppercase and lowercase letters.

9.4 Changing Window Proportions

You can change the proportions of the Program Window, Source Window, Memory Window and ASM Watch Window using the mouse as described below.

- Program Window and Source Window

When in disassemble display mode, you can change the relative proportions of the object code display area (<Objcode>) and the two parts (<Label> and <Mnemonic>) of the Program display area.

Drag to resize.

BRK	Objcode	Label	Mnemonic
-	AD1301	.D3	LDA 0113H
-	18		CLC

- Memory Window

You can change the relative proportions of the label display area (<LABEL>) and the memory content display area (<DATA>).

Drag to resize.

Address	LABEL	DATA
007B		00 <--- [S]
007C		03

- ASM Watch Window

You can change the relative proportion of the expression display area (<Expr>).

Drag to resize.

Addr:Bit	Expr	Sz	Rdx	Data
0100	DATA1	B	Hex	03
0101	DATA2	B	Hex	00

- Coverage Window

You can change the relative proportion of the Function me display area (<Function>).

Drag to resize.

Function	Start	E
_main	00BD0B	00E
_demo_two	00BD1A	00E

9.5 Switching Over Active Windows

PD38SIM requires that the window to be operated on is active. In addition to using the mouse to switch over the active windows by clicking on a desired window, you can switch over the active windows from the keyboard.

To switch over the active windows from the keyboard, enter the keys as follows:

[Ctrl] + [TAB]

Hold down the Shift key while you enter the above keys, and the active windows will be switched over in reverse order.

9.6 Displaying the Version of PD38SIM

Select the following from the PD38SIM Window menu:

[Help] -> [About..]

The About dialog box, which shows the PD38SIM version is displayed.

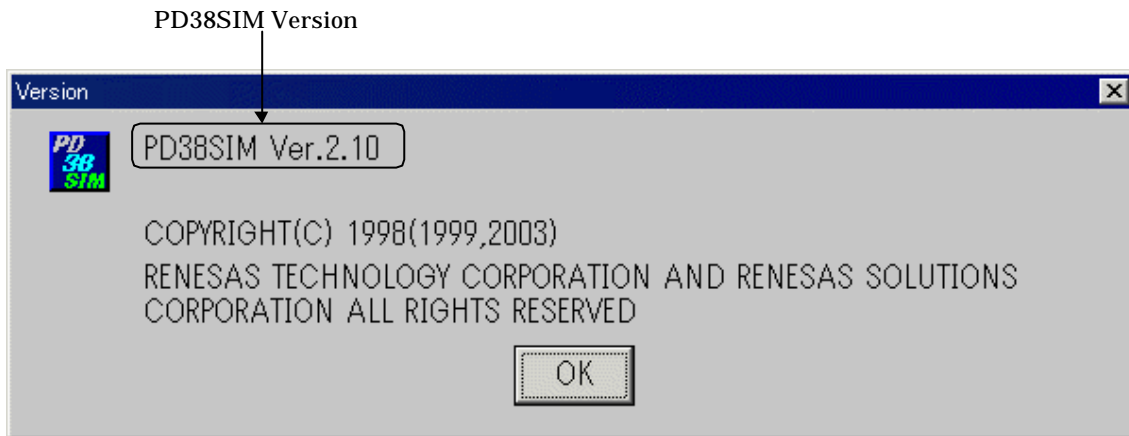

Press "OK" to close the About dialog box.

9.7 To Configure the operation of the PD38SIM

Select the following from the PD38SIM Window menu:

[Environ] -> [Customize...]

The Customize dialog box, to configure the operation of the PD38SIM.

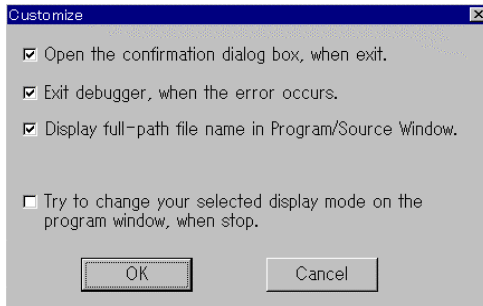

- Open the confirmation dialog box, when exit.
- Exit debugger, when the error occurs.
- Display full-path name in Program/Source Window.
- Try to change your selected display mode on the program window, when stop.

9.8 To Open the Editor

The following show how to open the editor which you usually use.

1. Registering the Editor

Select the pop-up menu [Entry Editor] in the Program window and specify the editor program and their parameters in the following dialog box.

You can specify the parameters of %F as the file name and %L as the line number to the editor if the editor is possible.

About parameters of the editor you use, refer the manual of the editor.

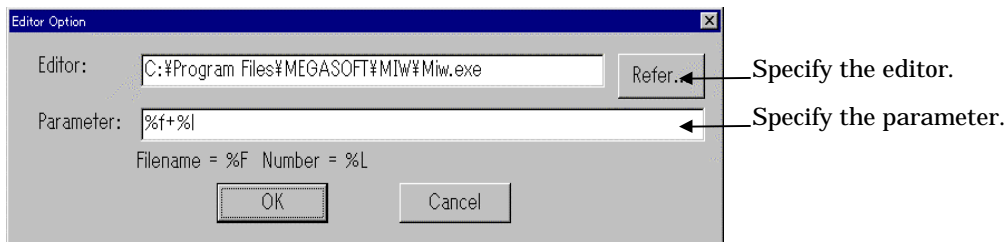

2. Opening the Editor

Select the pop-up menu [Open Editor] in the program window.

High-end Debugging

1 Setting Virtual Port Inputs in I/O Window

1.1 Overview

The Virtual Port Input function allows you to simulate data inputs and similar other operations performed on the ports defined in the SFR.

Data can be input to memory at one of the following timings:

1. If you want data to be input to some memory location with the lapse of time
Data can be input when program execution has reached a specified number of cycles.
In this case, set cycle-synchronized inputs.
2. If you want data to be input when some memory location is read
Data can be input when the program accesses a specified memory location for read.
For example, this method can be used in cases where you want a variable (e.g., global variables located at fixed addresses) to be assigned a value when it is read.
In this case, set read access-synchronized inputs.
3. If you want data to be input when some virtual interrupt occurs
Data can be input when a specified virtual interrupt is generated. For example, this method can be used in cases where memory for the SFR is referenced in an interrupt handler.
In this case, set interrupt-synchronized inputs.

1.2 Setting Cycle-synchronized Inputs

To set cycle-synchronized virtual port inputs, choose the I/O Window menus [Option] -> [Setup] (or the Setup button). The dialog box shown below will appear.

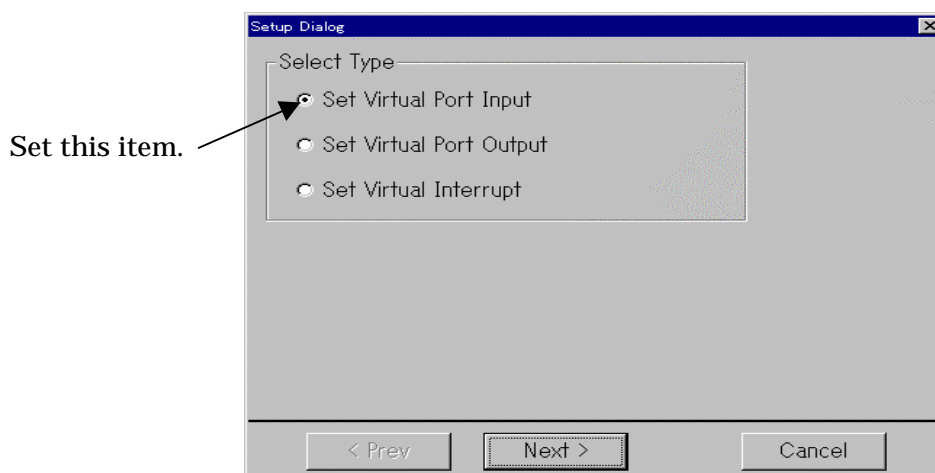

Here, choose the item Set Virtual Port Input and press the Next button. (Or press the Cancel button if you want cancel the setup session and close the dialog box.) A dialog box for setting up virtual port input timings will appear.

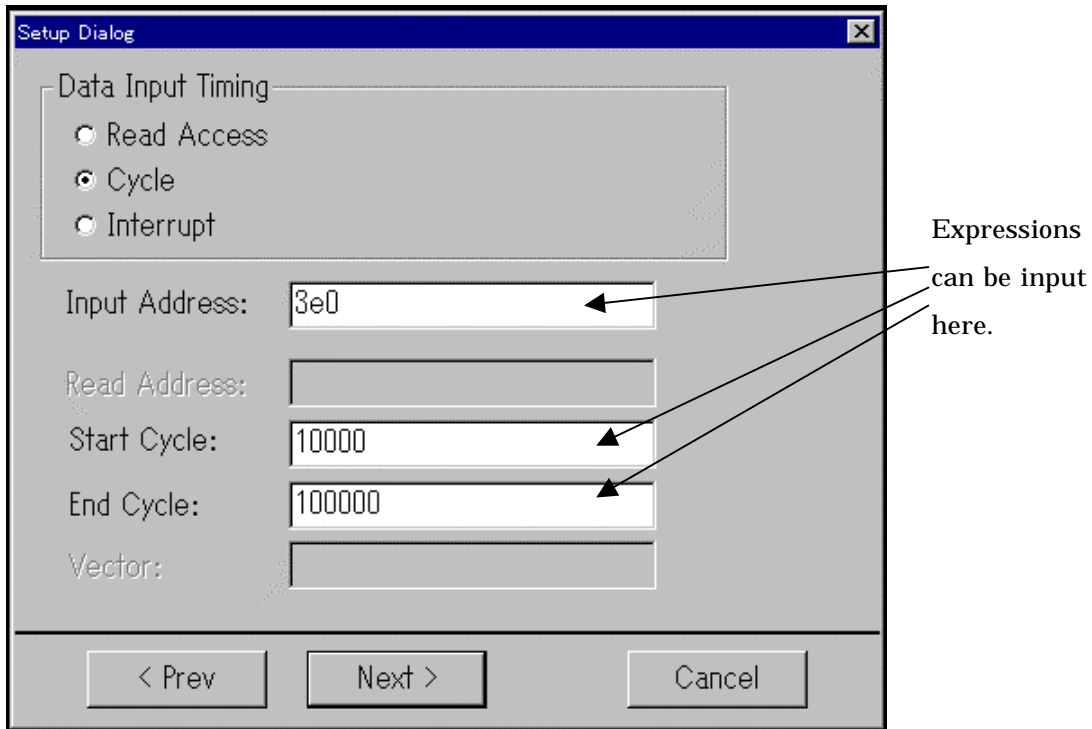

First, choose Cycle in the Data Input Timing column. Next, enter an address for virtual port input in the Input Address column (the address to which you want data to be input) using a hexadecimal number. Then enter the cycles at which you want the virtual port input to be started and ended for Start cycle and End cycle, respectively, using decimal numbers. Then press the Next button. (Or press the Prev button here if you want to return to the previous dialog box.)

A matrix dialog box for setting the virtual port input data will appear.

The Setup Dialog window contains a table with the following data:

Cycle	0	1	2	3	4	5	6	7	8	9
10000	11									
10010							22			
10020										
10030	33									
10040										
10050			44							
10060							55			
10070										
10080										
10090										

Annotations in the image:

- Up/Down buttons: Finds the previous data you've set (UP) or the next data (DOWN).
- Element 22: The setup example in this element specifies that "data 0x22 be set at the 10,016th cycle."
- Next button: Double-click on an element you want and set the desired input value in it.

In this dialog box, set the data you want to be actually input to memory. Follow the procedure below to set data:

1. Move the mouse cursor to the "cycles" location (called an element) where you want data to be set, then double-click the left mouse button. (Or you can scroll the screen to go to the desired location.)
2. Input data in the selected place using a hexadecimal number. The data size that can be input is one byte (from 0x0 up to 0xFF).
3. Repeat steps 1 and 2 as many times as the number of data you want to set.

When you finished entering all data, press the Next button.

A dialog box for saving the virtual port input data you've set to a file (virtual port input file) will appear.

The Save Data dialog box shows the following configuration:

- Save in: IO_Samples
- File name: input.scr
- Save as type: Script Files (*.scr)

Here, enter the directory and file names in which you want the data you've set to be saved. The saved file can be loaded into PD38SIM back again by using the I/O Window menus [Option] -> [Load] (or the Load button).

When you've input a file name, press the Save button.

Thus, you've finished setting the cycle-synchronized virtual port inputs.

1.3 Setting Read Access-synchronized Inputs

To set read access-synchronized virtual port inputs, choose the I/O Window menus [Option] -> [Setup] (or the Setup button). The dialog box shown below will appear.

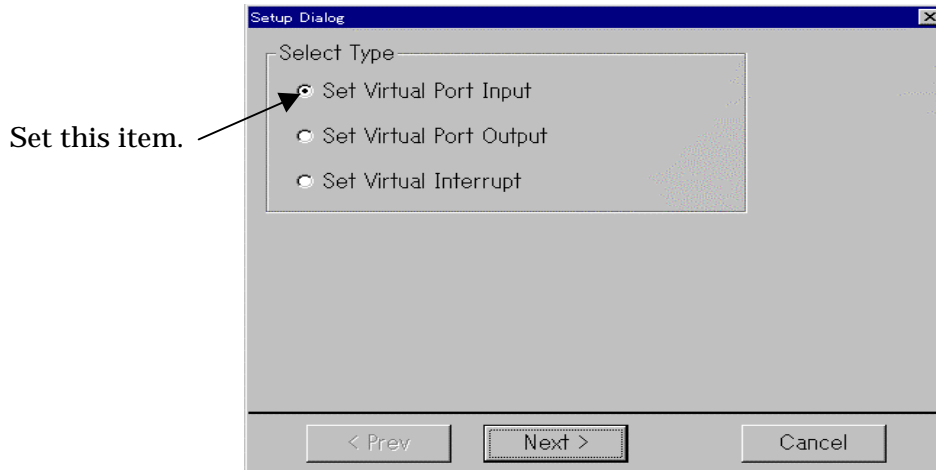

Here, choose the item Set Virtual Port Input and press the Next button. (Or press the Cancel button if you want cancel the setup session and close the dialog box.) A dialog box for setting up virtual port input timings will appear.

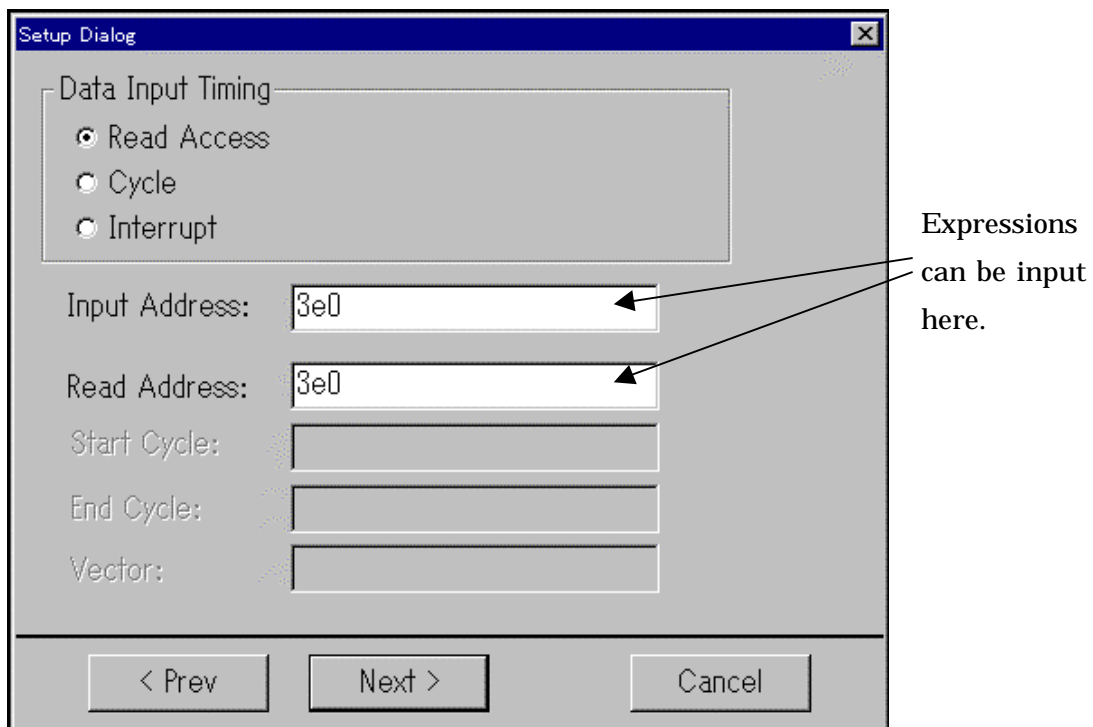

First, choose Read Access in the Data Input Timing column. Next, enter an address for virtual port input in the Input Address column (the address to which you want data to be input) using a hexadecimal number. Then enter the address to be accessed for read (to read data from memory) in the Read Address column. (Virtual port inputs are executed when the memory address you've specified here is accessed for read.) Then press the Next button. (Or press the Prev button here if you want to return to the previous dialog box.) A matrix dialog box for setting the virtual port input data will appear.

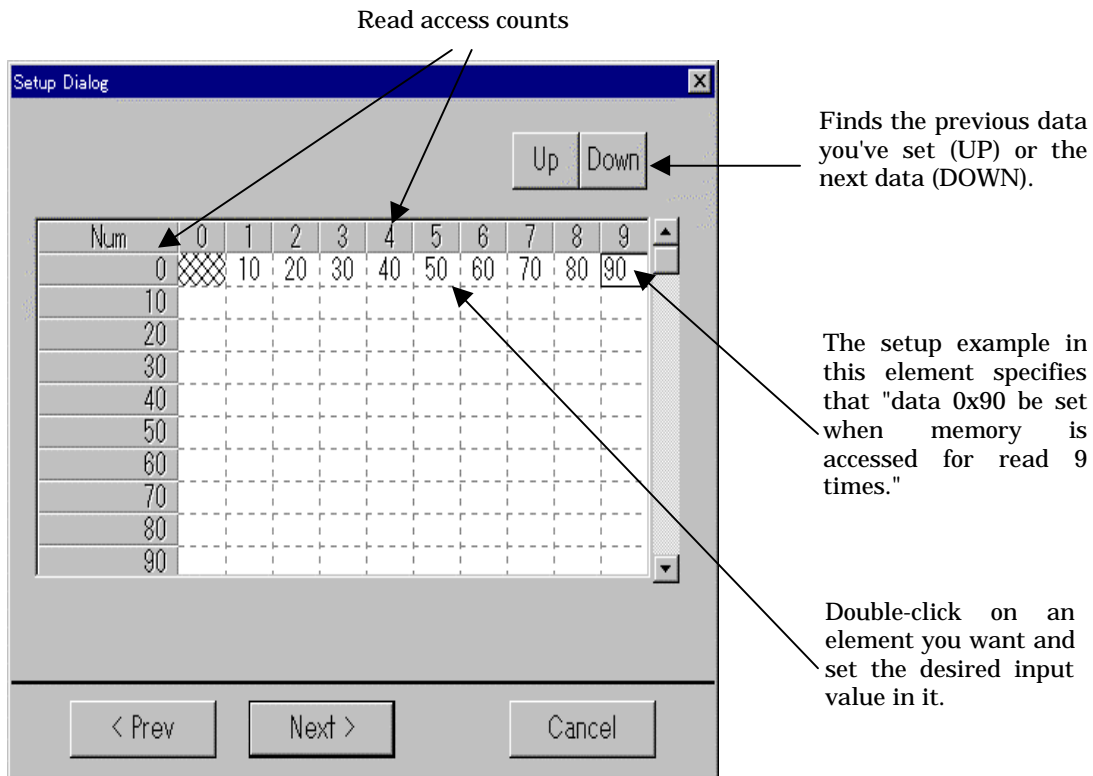

In this dialog box, set the data you want to be actually input to memory. Follow the procedure below to set data:

1. Move the mouse cursor to the "read access counts" location (called an element) where you want data to be set, then double-click the left mouse button. (Or you can scroll the screen to go to the desired location.)
2. Input data in the selected place using a hexadecimal number. The data size that can be input is one byte (from 0x0 up to 0xFF).
3. Repeat steps 1 and 2 as many times as the number of data you want to set.

When you finished entering all data, press the Next button.

A dialog box for saving the virtual port input data you've set to a file (virtual port input file) will appear.

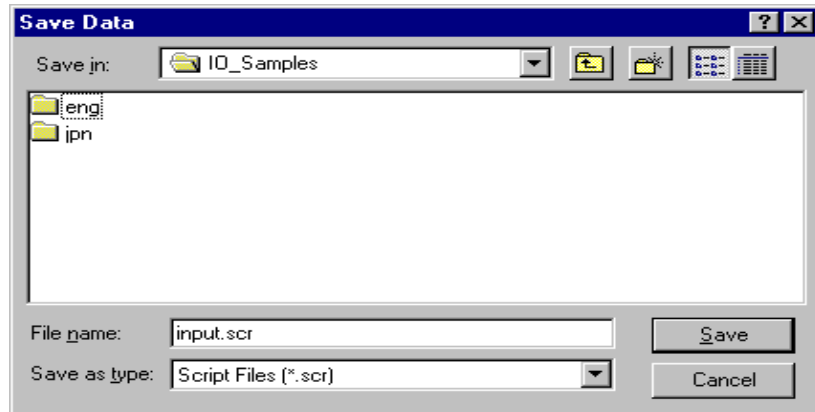

Here, enter the directory and file names in which you want the data you've set to be saved. The saved file can be loaded into PD38SIM back again by using the I/O Window menus [Option] -> [Load] (or the Load button).

When you've input a file name, press the Save button.

Thus, you've finished setting the read access-synchronized virtual port inputs.

1.4 Setting Interrupt-synchronized Inputs

To set interrupt-synchronized virtual port inputs, choose the I/O Window menus [Option] -> [Setup] (or the Setup button). The dialog box shown below will appear.

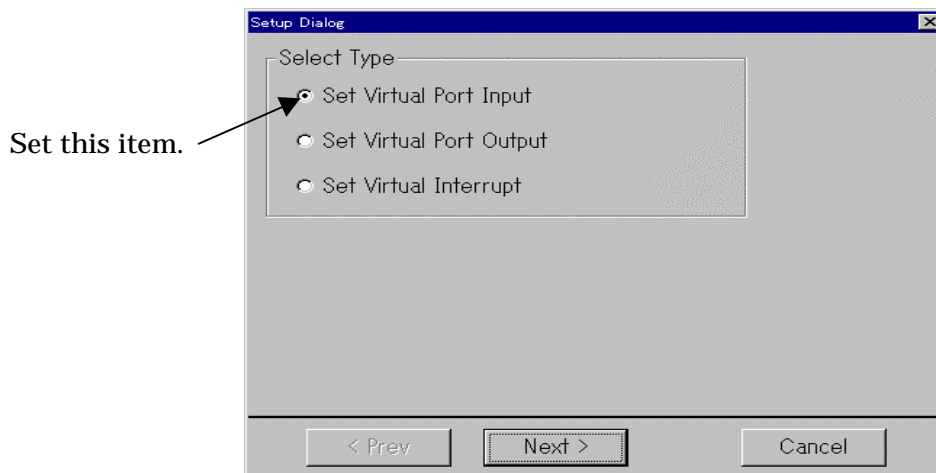

Here, choose the item Set Virtual Port Input and press the Next button. (Or press the Cancel button if you want cancel the setup session and close the dialog box.) A dialog box for setting up virtual port input timings will appear.

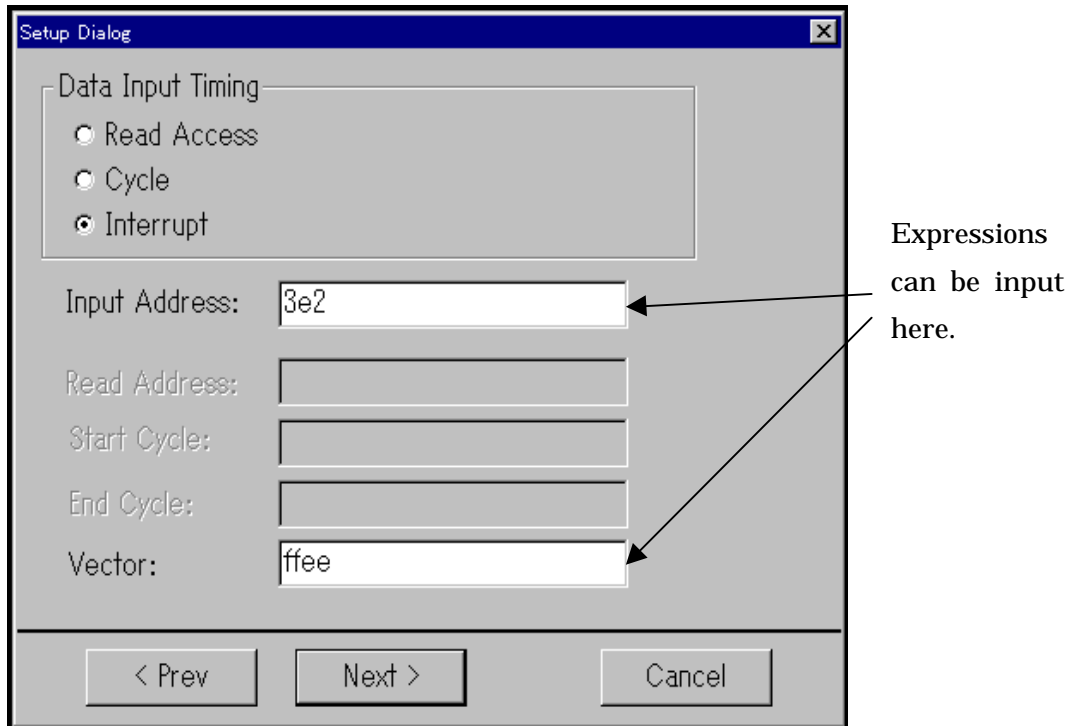

First, choose Interrupt in the Data Input Timing column. Next, enter an address for virtual port input in the Input Address column (the address to which you want data to be input) using a hexadecimal number. Then enter the vector address of a virtual interrupt that signals timing for virtual port input in the Vector Address column. (Or press the Prev button here if you want to return to the previous dialog box.)

A matrix dialog box for setting the virtual port input data will appear.

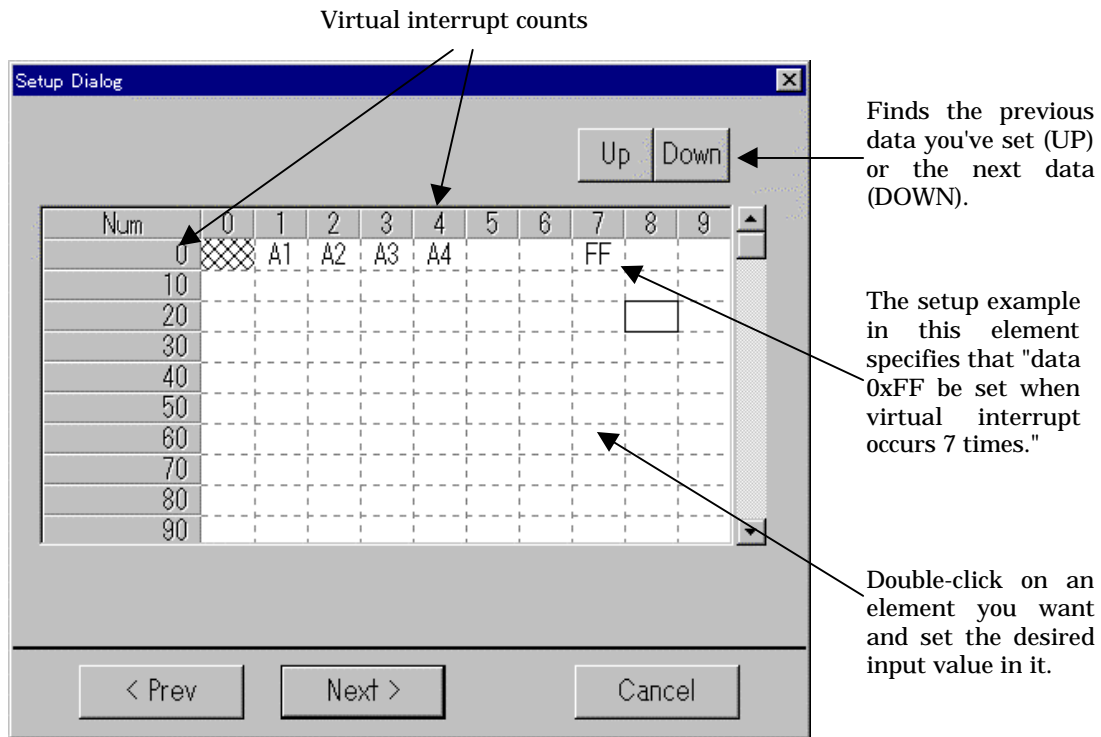

In this dialog box, set the data you want to be actually input to memory. Follow the procedure below to set data:

1. Move the mouse cursor to the "virtual interrupt counts" location (called an element) where you want data to be set, then double-click the left mouse button. (Or you can scroll the screen to go to the desired location.)
2. Input data in the selected place using a hexadecimal number. The data size that can be input is one byte (from 0x0 up to 0xFF).
3. Repeat steps 1 and 2 as many times as the number of data you want to set.

When you finished entering all data, press the Next button.

A dialog box for saving the virtual port input data you've set to a file (virtual port input file) will appear.

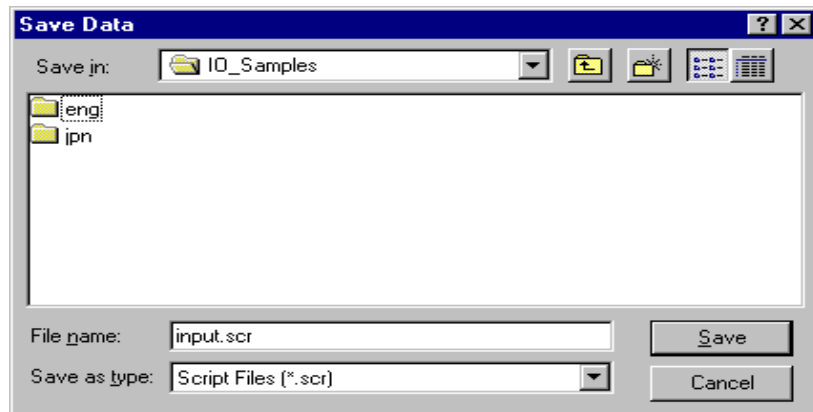

Here, enter the directory and file names in which you want the data you've set to be saved. The saved file can be loaded into PD38SIM back again by using the I/O Window menus [Option] -> [Load] (or the Load button).

When you've input a file name, press the Save button.

Thus, you've finished setting the virtual interrupt-synchronized virtual port inputs.

2 Setting Virtual Port Outputs in I/O Window

2.1 Overview

The Virtual Port Output function allows data values written to some memory address by a program to be recorded along with cycles at which data was written. The recorded data can be displayed for verification in graphic or numeric form.

The maximum number of data that can be recorded by this function is 30,000 entries counted from the beginning of program execution.

2.2 Setting Virtual Port Outputs

To set virtual port outputs, choose the I/O Window menus [Option] -> [Setup] (or the Setup button). The dialog box shown below will appear.

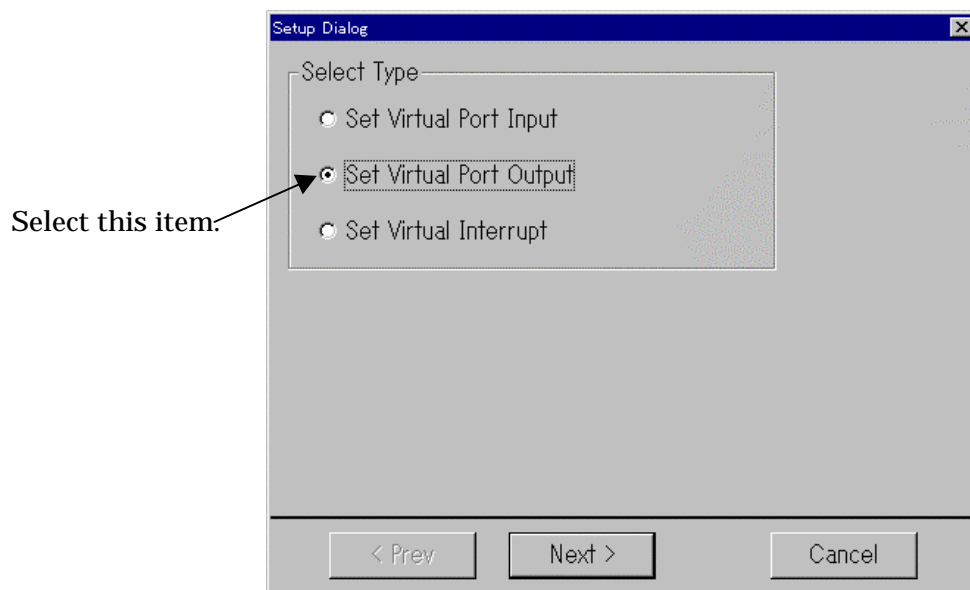

Here, choose the item Set Virtual Port Output and press the Next button. (Or press the Cancel button if you want cancel the setup session and close the dialog box.) A dialog box for setting the address you want to be monitored for virtual port output will appear.

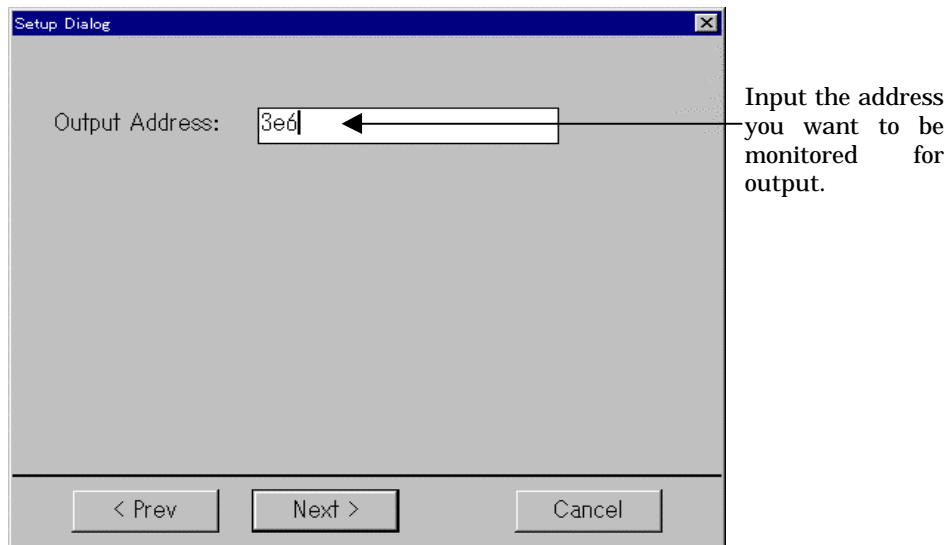

Input the address you want to be monitored for virtual port output in the Output Address column. Then press the Next button.

A dialog box for specifying a file (virtual port output file) to which you want the virtual port output results to be saved (recorded) will appear. (PD38SIM saves the virtual port output results that have occurred during program execution to this file and references it when the program stops running.)

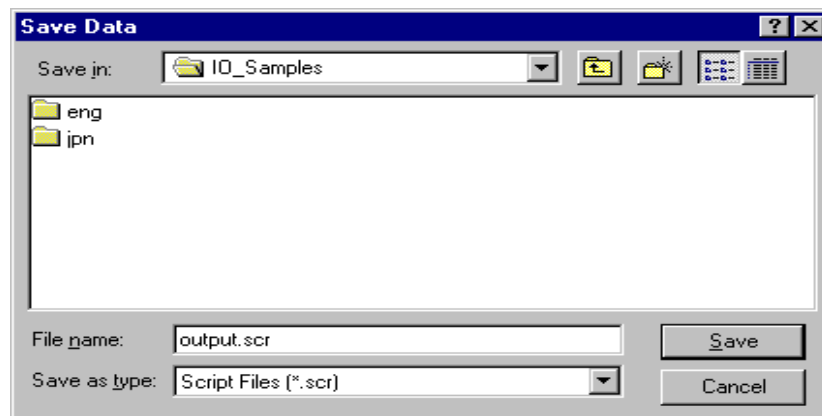

Here, input the directory and file names in which you want the virtual port output file to be saved. When you've input a file name, press the Save button. Thus, you've finished setting virtual port outputs.

3 Setting Virtual Interrupts in I/O Window

3.1 Overview

The Virtual Interrupt function allows you to generate interrupts in a simulated manner without having to actually generate them. Using this function you can generate timer interrupts in a simulated manner.

Virtual interrupts can be generated at one of the following timings:

1. If you want virtual interrupts to be generated with the lapse of time
Virtual interrupts can be generated when program execution has reached a specified number of cycles.
In this case, set cycle-synchronized interrupts.

2. If you want virtual interrupts to be generated when the program executes a specified address
Use this method if you want virtual interrupts to be generated when some specific function is executed.
In this case, set executed address-synchronized interrupts.

3.2 Setting Cycle-synchronized Interrupts

To set cycle-synchronized virtual interrupts, choose the I/O Window menus [Option] -> [Setup] (or the Setup button). The dialog box shown below will appear.

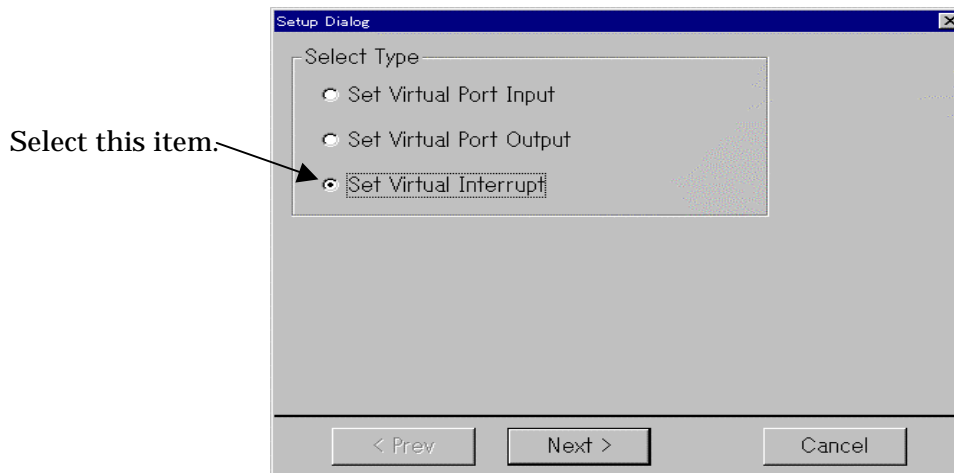

Here, choose the item Set Virtual Interrupt and press the Next button. (Or press the Cancel button if you want cancel the setup session and close the dialog box.) A dialog box for setting up virtual interrupt timings will appear.

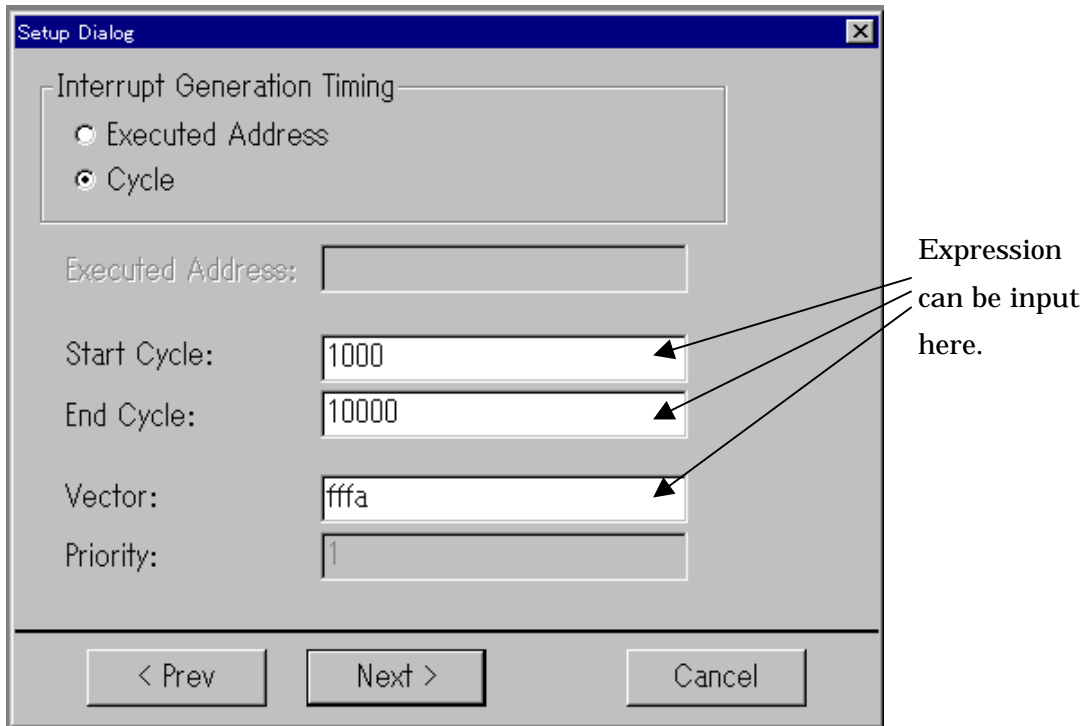

First, choose Cycle in the Interrupt Generation Timing column. Next, specify the cycles at which you want a virtual interrupt to be started and ended for Start cycle and End cycle, respectively, using decimal numbers. Then specify the vector address of the virtual interrupt to be generated for Vector Address using hexadecimal numbers. Then press the Next button. (Or press the Prev button here if you want to return to the previous dialog box.)

A matrix dialog box for setting virtual interrupts will appear.

Setup Dialog

Cycle	0	1	2	3	4	5	6	7	8	9
10000								*		
10010										
10020										
10030				*						
10040			*							
10050										
10060										
10070										
10080										
10090										

Up Down

Finds the previous data you've set (UP) or the next data (DOWN).

The setup example in this element specifies that "virtual interrupt be generated at the 10,007th cycle."

Point to the desired element and click the mouse button. The selected element is marked by an asterisk (*).

< Prev Next > Cancel

In this dialog box, set the virtual interrupts you want to be actually generated. Follow the procedure below to set virtual interrupts:

1. Move the mouse cursor to the "cycles" location (called an element) where you want a virtual interrupt to be generated, then click the left mouse button. (Or you can scroll the screen to go to the desired location.)
2. The element is marked by an asterisk (*) when you've clicked. Click at the same place again if you want the virtual interrupt you've set to be canceled. In this case, the asterisk goes out.
3. Repeat steps 1 and 2 as many times as the number of virtual interrupts to be generated.

When you finished setting all virtual interrupts, press the Next button.

A dialog box for saving the virtual interrupts you've set to a file (virtual interrupt file) will appear.

Save Data

Save in: IO_Samples

eng
ipn

File name: intr.scr

Save as type: Script Files (*.scr)

Save Cancel

Here, enter the directory and file names in which you want the data you've set to be saved. The saved file can be loaded into PD38SIM back again by using the I/O Window menus [Option] -> [Load] (or the Load button).

When you've input a file name, press the Save button.

Thus, you've finished setting cycle-synchronized virtual interrupts.

3.3 Setting Executed Address-synchronized Interrupts

To set executed address-synchronized virtual interrupts, choose the I/O Window menus [Option] -> [Setup] (or the Setup button). The dialog box shown below will appear.

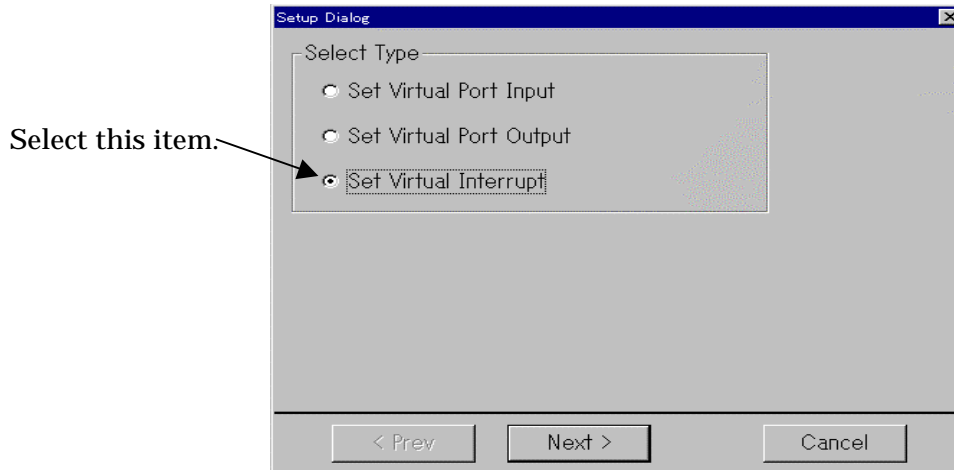

Here, choose the item Set Virtual Interrupt and press the Next button. (Or press the Cancel button if you want cancel the setup session and close the dialog box.) A dialog box for setting up virtual interrupt timings will appear.

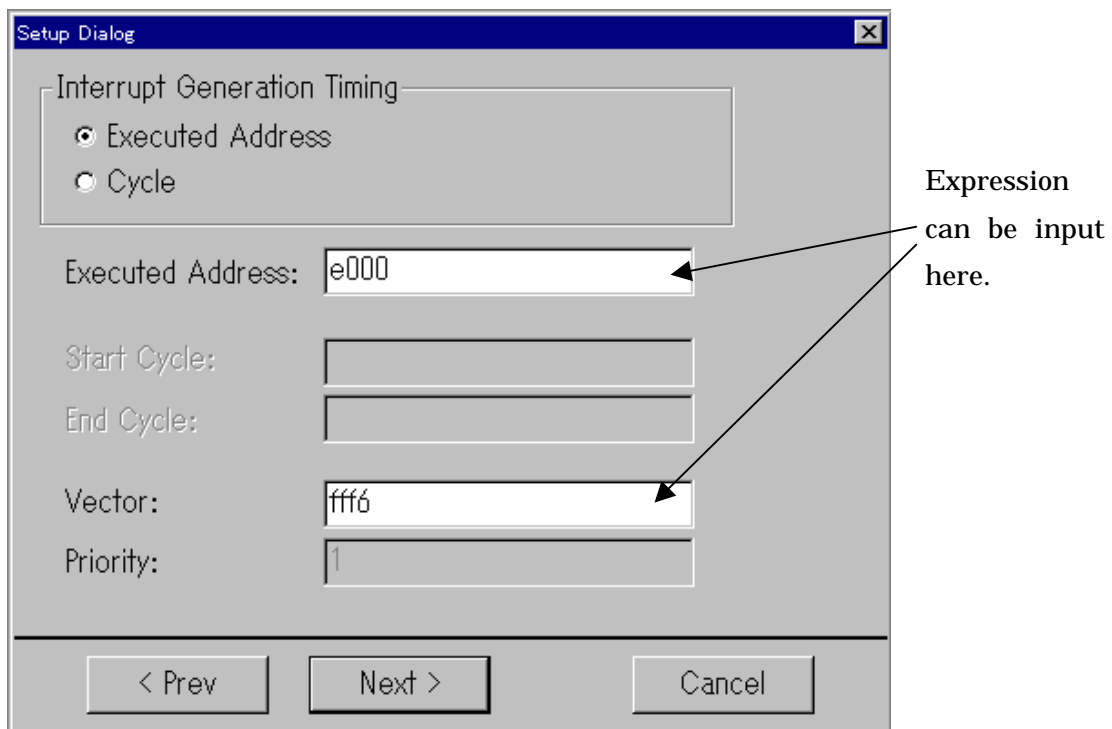

First, choose Executed Address in the Interrupt Generation Timing column. Next, specify the executed address (i.e., the address at which a virtual interrupt is generated when it is executed) for Executed Address. Then specify the vector address of the virtual interrupt to be generated for Vector Address using hexadecimal numbers. Then press the Next button. (Or press the Prev button here if you want to return to the previous dialog box.) A matrix dialog box for setting virtual interrupts will appear.

Setup Dialog

Up Down

Num	0	1	2	3	4	5	6	7	8	9
0	*	*	*	*	*	*	*	*	*	*
10	*	*		*		*				
20										
30										
40										
50										
60										
70										
80										
90										

< Prev Next > Cancel

Finds the previous data you've set (UP) or the next data (DOWN).

The setup example in this element specifies that "virtual interrupt be generated when a specified address is executed 7 times."

Point to the desired element and click the mouse button. The selected element is marked by an asterisk

In this dialog box, set the virtual interrupts you want to be actually generated. Follow the procedure below to set virtual interrupts:

1. Move the mouse cursor to the "cycles" location (called an element) where you want a virtual interrupt to be generated, then click the left mouse button. (Or you can scroll the screen to go to the desired location.)
2. The element is marked by an asterisk (*) when you've clicked. Click at the same place again if you want the virtual interrupt you've set to be canceled. In this case, the asterisk goes out.
3. Repeat steps 1 and 2 as many times as the number of virtual interrupts to be generated.

When you finished setting all virtual interrupts, press the Next button.

A dialog box for saving the virtual interrupts you've set to a file (virtual interrupt file) will appear.

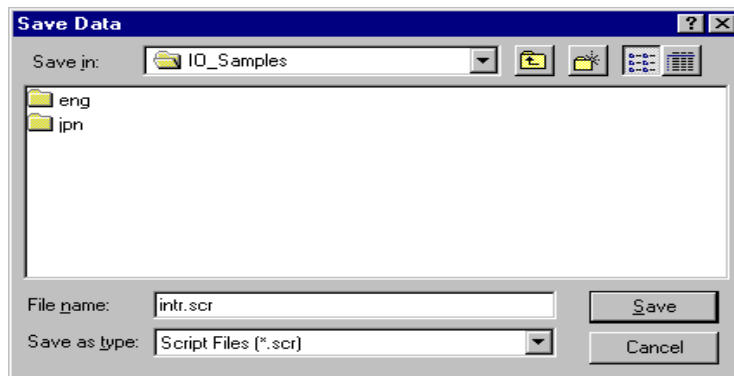

Here, enter the directory and file names in which you want the data you've set to be saved. The saved file can be loaded into PD38SIM back again by using the I/O Window menus [Option] -> [Load] (or the Load button). When you've input a file name, press the Save button. Thus, you've finished setting executed address-synchronized virtual interrupts.

4 Other Functions of I/O Window

4.1 Changing Setup Data of Virtual Port Inputs and Virtual Interrupts

The data for virtual port inputs or virtual interrupts you've set using the Setup menu can be changed.

4.1.1 Changing Setup Data of Virtual Port Inputs

To change the setup data, choose the menus [Option] -> [Modify] (or the Modify button). A dialog box like the one shown below will appear.

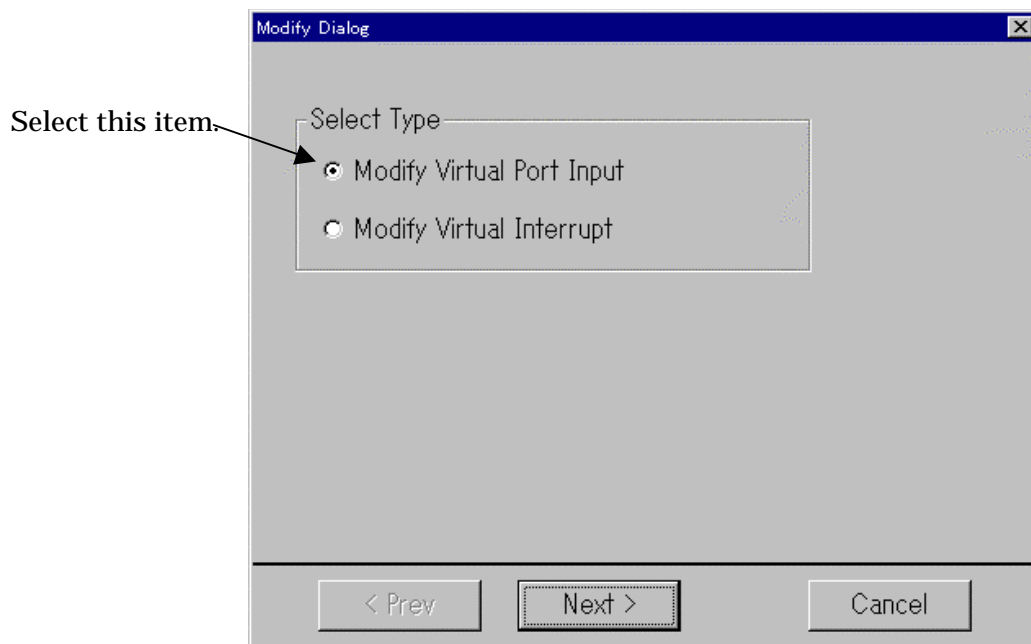

Here, choose the item Modify Virtual Port Input and press the Next button. (Or press the Cancel button if you want cancel the session and close the dialog box.) A dialog box for selecting the virtual port input whose settings you want to be changed will appear.

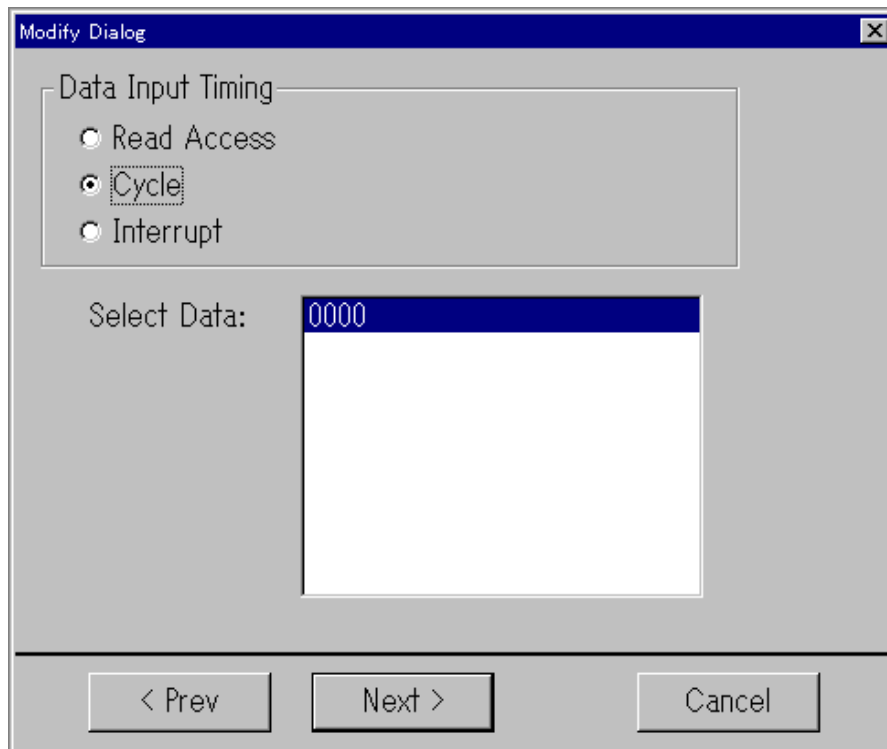

First, choose the type of virtual port input you want to be changed in the Data Input Timing column. When selected, the currently set virtual port inputs are listed in the Select Data column. Here, choose the virtual port input you want to be changed. Then press the Next button. (Or press the Prev button here if you want to return to the previous dialog box.)

A matrix dialog box for changing virtual port inputs will appear.

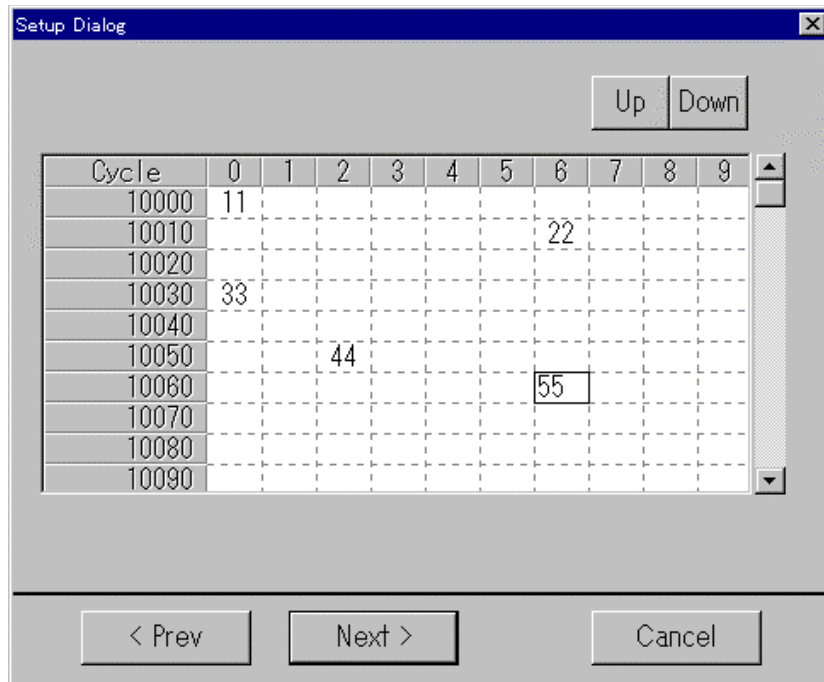

Here, change the data for the selected virtual port input as necessary. Data can be changed in the same way that data is set. (Refer to Section 1., "Setting Virtual Port Inputs in I/O Window.")

After changing the data, press the Next button.

A dialog box for saving the virtual port input data you've set (virtual port input file) will appear.

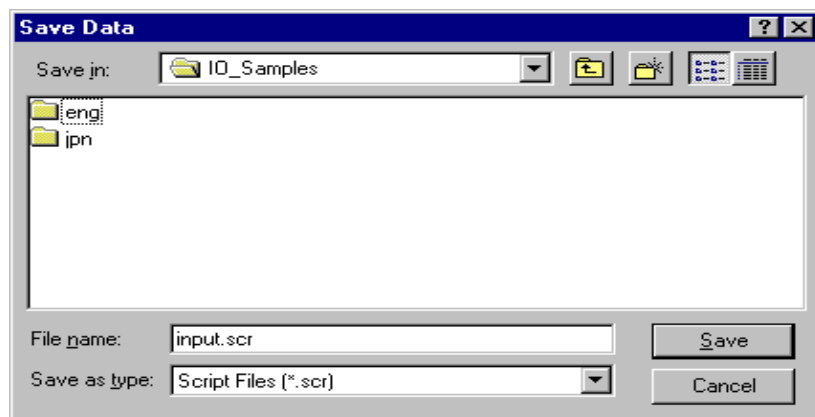

Here, enter the directory and file names in which you want the data you've set to be saved. The saved file can be loaded into PD38SIM back again by using the I/O Window menus [Option] -> [Load] (or the Load button).

When you've input a file name, press the Save button.

Thus, you've finished changing virtual port input data.

4.1.2 Changing Setup Data of Virtual Interrupts

To change the setup data, choose the menus [Option] -> [Modify] (or the Modify button). A dialog box like the one shown below will appear.

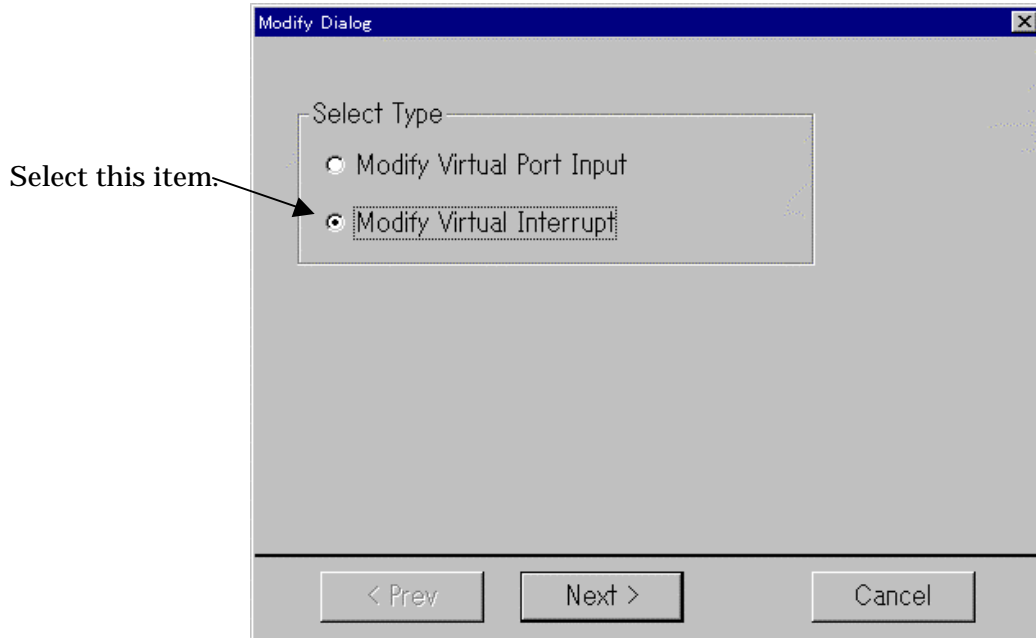

Here, choose the item Modify Virtual Interrupt and press the Next button. (Or press the Cancel button if you want cancel the session and close the dialog box.) A dialog box for selecting the virtual interrupt whose settings you want to be changed will appear.

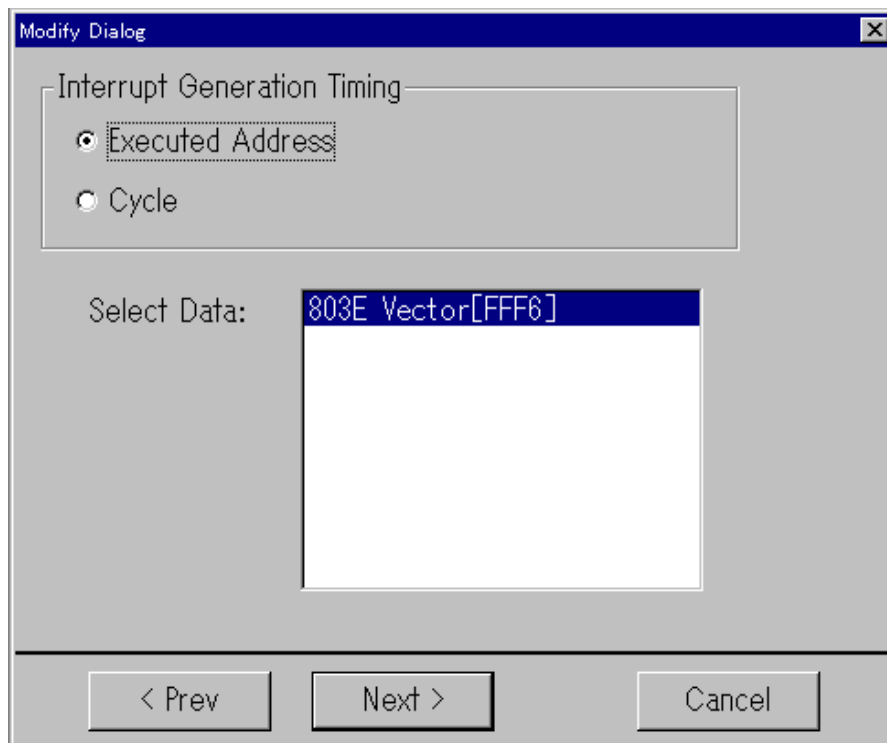

First, choose the type of virtual interrupt you want to be changed in the Interrupt Generation Timing column. When selected, the currently set virtual interrupts are listed in the Select Data column. Here, choose the virtual interrupt you want to be changed. Then press the Next button. (Or press the Prev button here if you want to return to the previous dialog box.)

A matrix dialog box for changing virtual interrupts will appear.

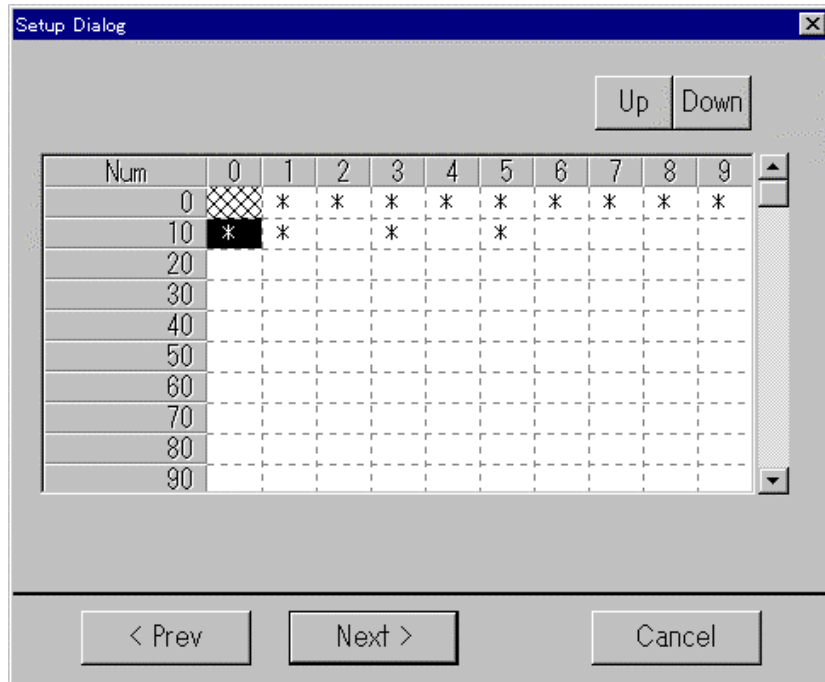

Here, change the data for the selected virtual interrupt as necessary. Data can be changed in the same way that data is set. (Refer to Section 3., "Setting Virtual Interrupts in I/O Window.")

After changing the data, press the Next button. A dialog box for saving the virtual interrupt data you've set (virtual interrupt file) will appear.

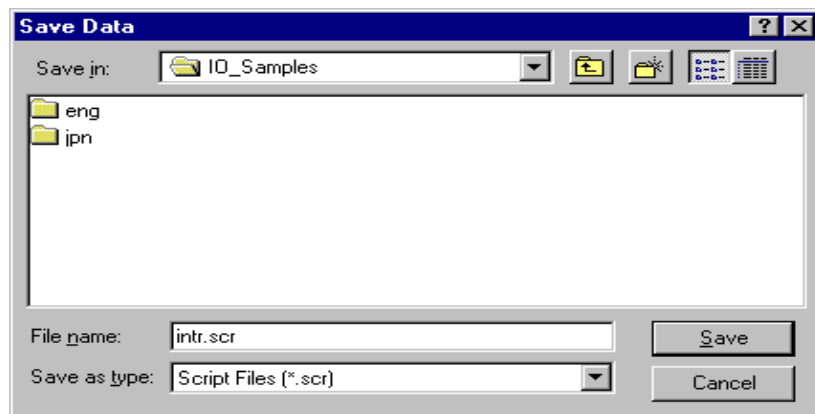

Here, enter the directory and file names in which you want the data you've set to be saved. The saved file can be loaded into PD38SIM back again by using the I/O Window menus [Option] -> [Load] (or the Load button).

When you've input a file name, press the Save button. Thus, you've finished changing virtual interrupt data.

4.2 Deleting Virtual Port Inputs, Virtual Port Outputs, Virtual Interrupts, or I/O Script Files Set

The virtual port inputs, virtual port outputs, virtual interrupts, or I/O script files you've set using the Setup menu can be deleted.

To delete one of these settings, choose the menus [Option] -> [Delete] (or the Delete button). A dialog box like the one shown below will appear.

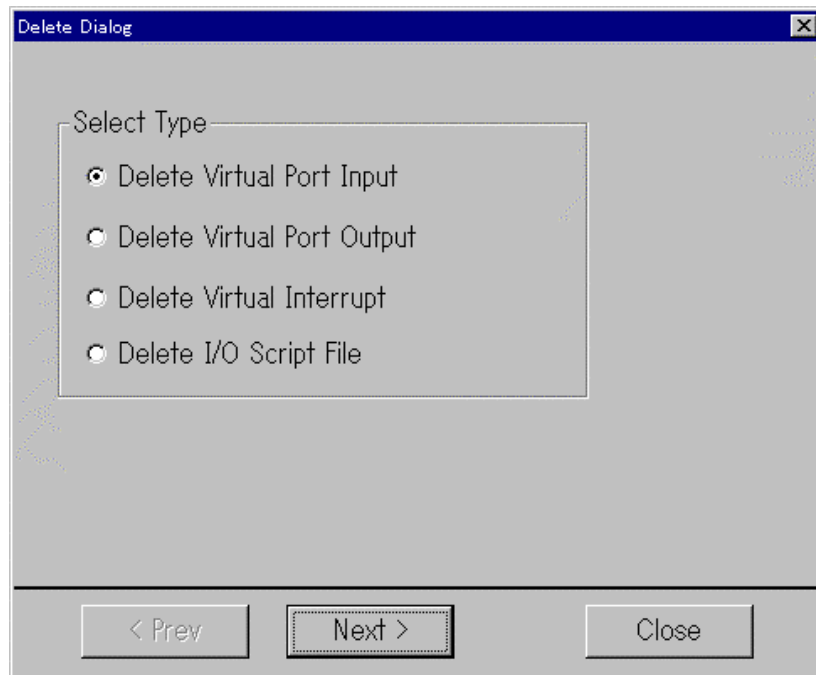

- To delete virtual port inputs that have been set, choose Delete Virtual Port Input.
- To delete virtual port outputs that have been set, choose Delete Virtual Port Output.
- To delete virtual interrupts that have been set, choose Delete Virtual Interrupt.
- To delete I/O script files that have been set, choose Delete I/O Script File.

When you've selected one, follow the procedure below to delete.

4.2.1 Deleting Virtual Port Input

After selecting Delete Virtual Port Input, press the Next button to bring up the dialog box shown below.

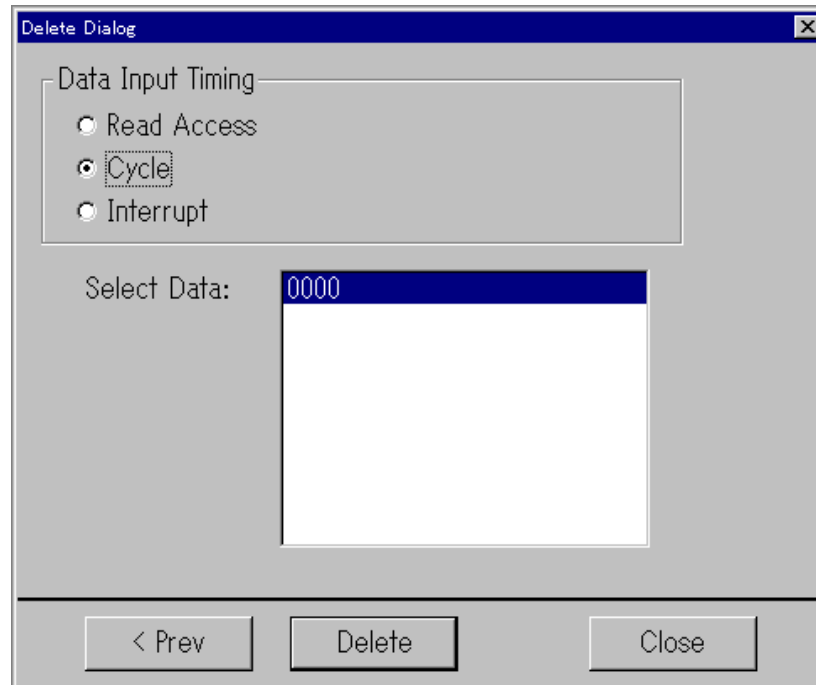

First, choose the type of virtual port input you want to be deleted in the Data Input Timing column. When selected, the currently set virtual port inputs are listed in the Select Data column. Here, choose the virtual port input you want to be deleted. Then press the Delete button. (Or press the Prev button here if you want to return to the previous dialog box.) Thus, the virtual port input is deleted. Press the Close button to close the dialog box.

4.2.2 Deleting Virtual Port Output

After selecting Delete Virtual Port Output, press the Next button to bring up the dialog box shown below.

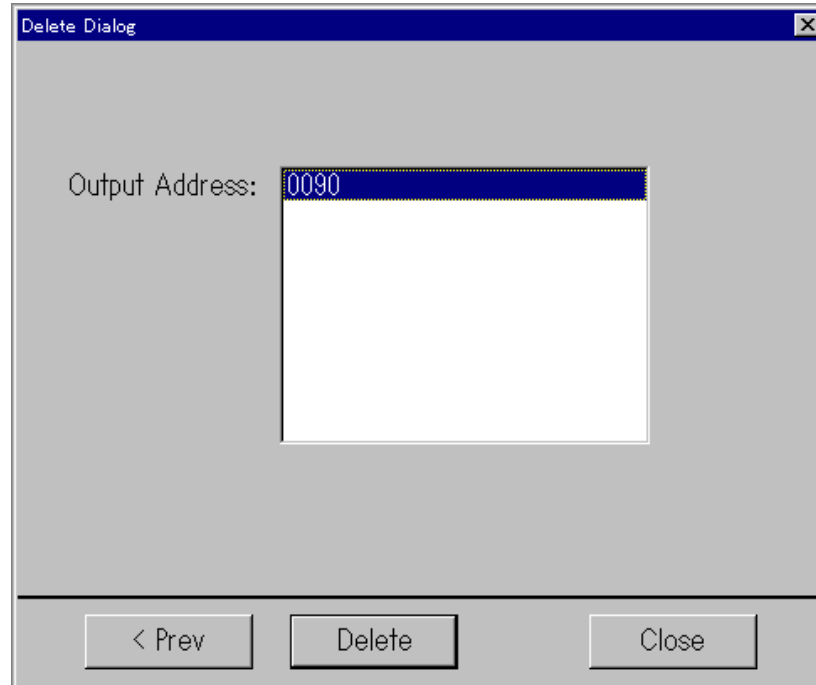

Here, choose the virtual port output you want to be deleted. Then press the Delete button. (Or press the Prev button here if you want to return to the previous dialog box.) Thus, the virtual port output is deleted. Press the Close button to close the dialog box.

4.2.3 Deleting Virtual Interrupt

After selecting Delete Virtual Interrupt, press the Next button to bring up the dialog box shown below.

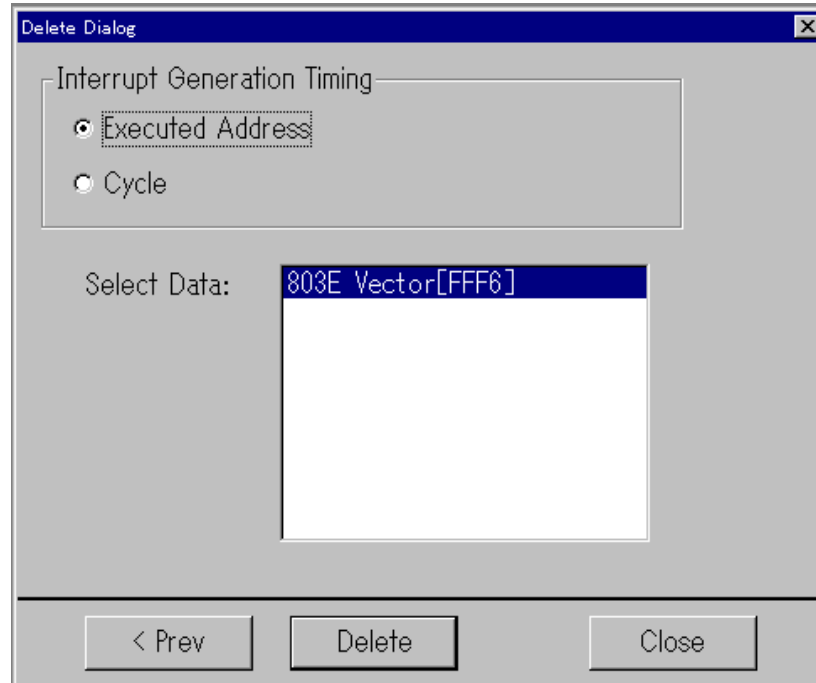

First, choose the type of virtual interrupt you want to be deleted in the Interrupt Generation Timing column. When selected, the currently set virtual interrupts are listed in the Select Data column. Here, choose the virtual interrupt you want to be deleted. Then press the Delete button. (Or press the Prev button here if you want to return to the previous dialog box.) Thus, the virtual interrupt is deleted. Press the Close button to close the dialog box.

4.2.4 Deleting I/O Script File

After selecting Delete I/O Script File, press the Next button to bring up the dialog box shown below.

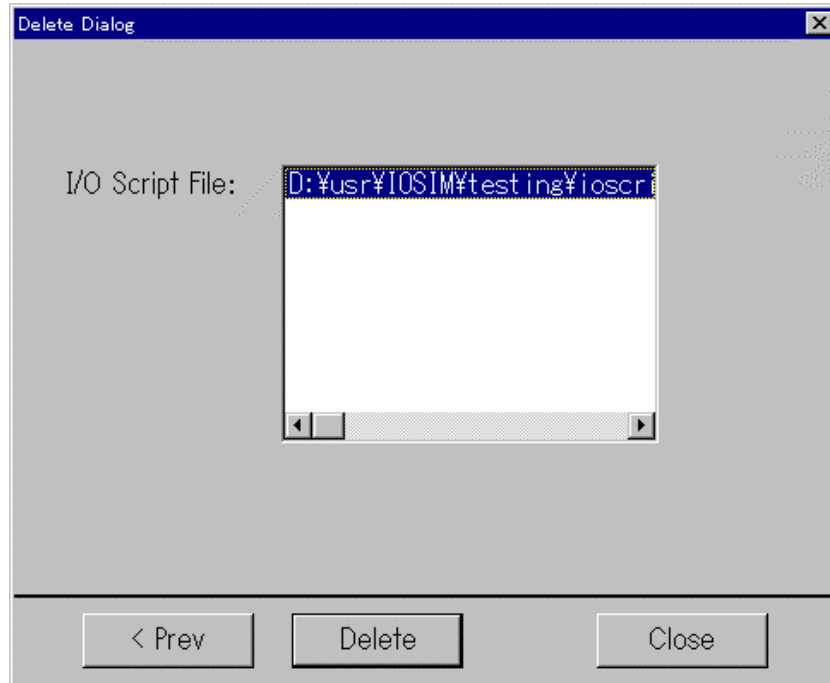

Here, choose the I/O script file you want to be deleted from registration. Then press the Delete button. (Or press the Prev button here if you want to return to the previous dialog box.) Thus, the I/O script file is deleted. Press the Close button to close the dialog box.

4.3 Changing Display Mode of Virtual Port Input, Virtual Port Output, or Virtual Interrupt

The display modes of the virtual port inputs, virtual port outputs, or virtual interrupts you've set using the Setup menu can be changed.

To change the display modes, choose the menus [Option] -> [Mode] (or the Mode button). A dialog box like the one shown below will appear.

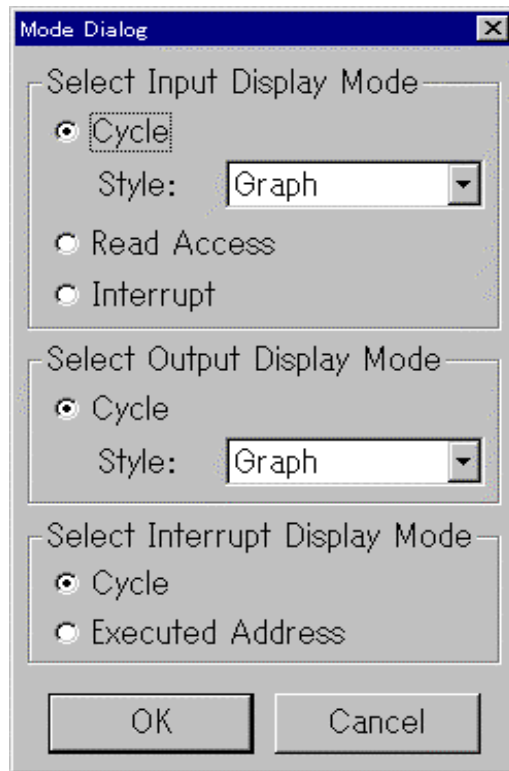

The following explains how to change each display mode.

4.3.1 Changing Display Mode of Virtual Port Input

1. For cycle-synchronized inputs
Choose Cycle in the Select Input Display Mode column. Then choose the desired display mode in the Style column.
 - Choose Chart if you want the selected input to be displayed in chart mode.
 - Choose Hex if you want the selected input to be displayed in hexadecimal mode.
 - Choose Graph if you want the selected input to be displayed in graphic mode.
2. For read access-synchronized inputs
Choose Read Access in the Select Input Display Mode column.
3. For interrupt-synchronized inputs
Choose Interrupt in the Select Input Display Mode column.

4.3.2 Changing Display Mode of Virtual Port Output

- Choose your desired display mode from Style in the Select Output Display Mode column.
- Choose Chart if you want the selected output to be displayed in chart mode.
 - Choose Hex if you want the selected output to be displayed in hexadecimal mode.
 - Choose Graph if you want the selected output to be displayed in graphic mode.

4.3.3 Changing Display Mode of Virtual Interrupt

1. For cycle-synchronized interrupts
Choose Cycle in the Select Interrupt Display Mode column.
2. For executed address-synchronized interrupts
Choose Executed Address in the Select Interrupt Display Mode column.

4.4 Changing Scale of Display Screen

The scale of the virtual port input, virtual port output, or virtual interrupt display screen can be changed. This means changing the number of cycles that can be displayed in one screen.

To change the display scale, choose the menus [Option] -> [Scale] (or the Scale button). A dialog box like the one shown below will appear.

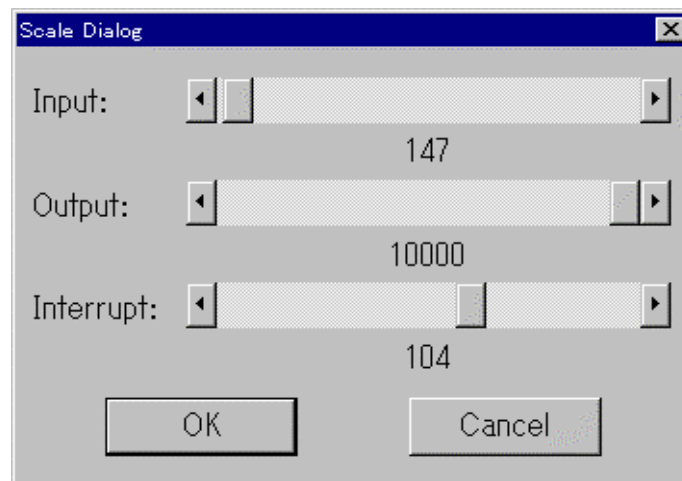

The following explains how to change the scale of each display screen.

1. To change the scale of the virtual port input display screen, slide the scroll bar in the Input column until the scale you want is reached.
2. To change the scale of the virtual port output display screen, slide the scroll bar in the Output column until the scale you want is reached.
3. To change the scale of the virtual interrupt display screen, slide the scroll bar in the Interrupt column until the scale you want is reached.

The display scale can be changed in the range of 1 to 10,000 [cycles].

For example, if you change the scale to 50 when displaying a virtual port input in chart mode, the data is displayed for 50 cycles in one screen.

Note, however, that when displayed in numeric form, the maximum scale is 50.

4.5 Changing Colors of Display Screen

The colors of the virtual port input, virtual port output, or virtual interrupt display screen can be changed.

You can change four colors in each data display area: grid lines, graph lines, text, and background.

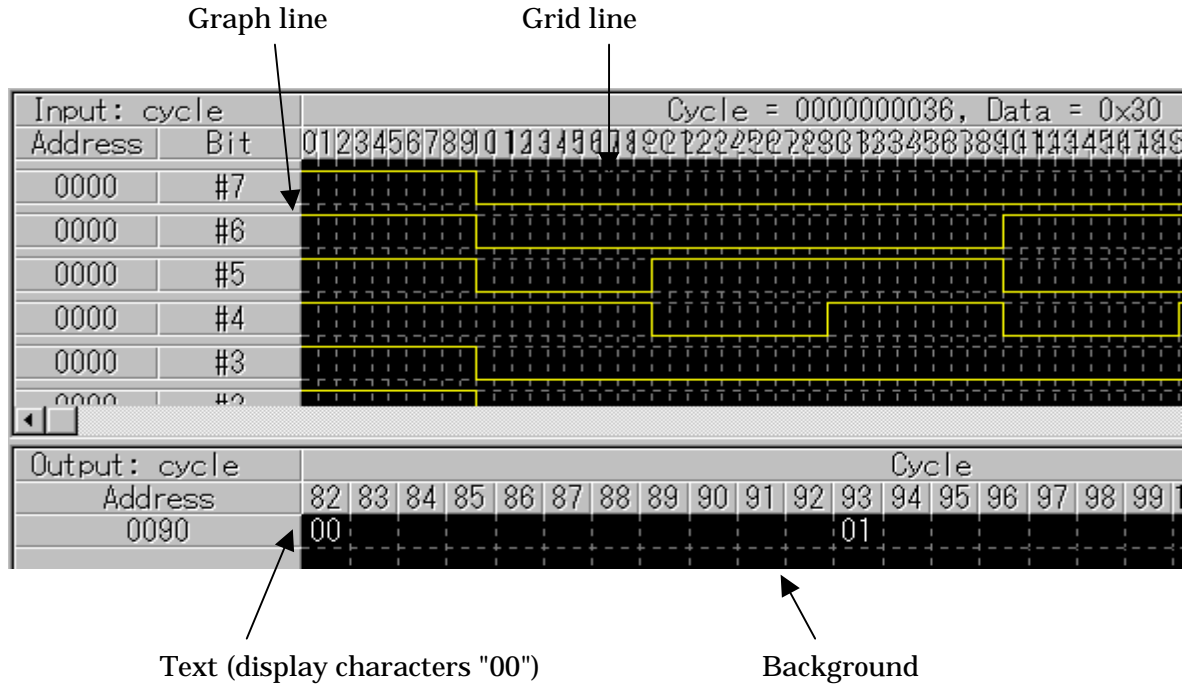

To change the display colors, choose the menu [Option] -> [Color] (or the Color button). A dialog box like the one shown below will appear.

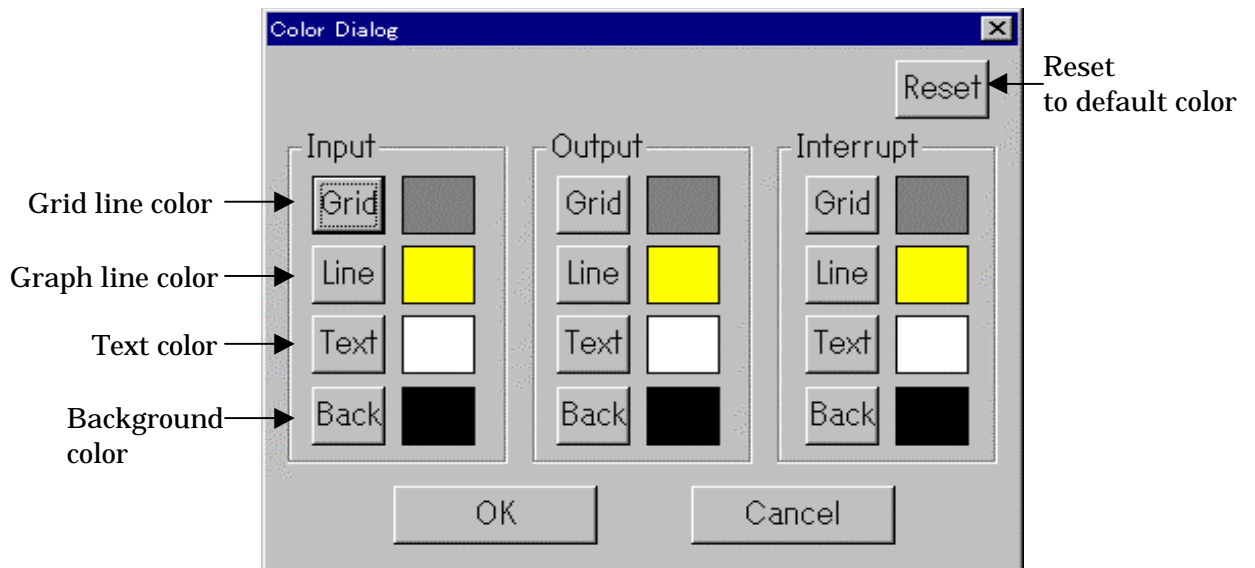

The following explains how to change colors in each display screen.

1. To change the colors of the virtual port input display screen
Press the button for the item whose color you want to be changed in the Input column.
A dialog box for selecting colors will appear. Use this dialog box to choose your desired colors.
2. To change the colors of the virtual port output display screen
Press the button for the item whose color you want to be changed in the Output column.
A dialog box for selecting colors will appear. Use this dialog box to choose your desired colors.
3. To change the colors of the virtual interrupt display screen
Press the button for the item whose color you want to be changed in the Interrupt column.
A dialog box for selecting colors will appear. Use this dialog box to choose your desired colors.

4.6 Searching for Display Data

The virtual port input or virtual interrupt data or the output result of virtual port output can be displayed at the left edge of the window after searching. However, the last data of each is displayed at the right edge.

The following shows how to search.

The screenshot shows the I/O Window interface with three main sections:

- Input: cycle**: Shows a table with columns for Address and Bit (0-31) and a corresponding waveform. The waveform shows data for bits #7 through #0.
- Output: cycle**: Shows a table with columns for Address and Bit (0-11) and a corresponding waveform. The waveform shows data for bits #7 through #0. The cycle number is 0000000991.
- Interrupt: cycle**: Shows a table with columns for Vec. (10000-10005) and a corresponding waveform. The waveform shows data for vector FFFA.

Arrows point to the right edge of each section, with a text box stating: "Point to somewhere in one of these areas and click the right mouse button. A popup menu for searching data will appear."

Move the mouse cursor to a position in one of the display areas where you want search for data to begin, then click the right mouse button. A popup menu like the one shown below will appear.

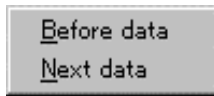

When you choose Before data here, data is searched backward from the position you've specified by clicking the mouse button. If you choose Next data here, data is searched forward from the position you've specified by clicking the mouse button.

4.7 Listing Registered I/O Script Files

The registered I/O scrip files can be listed on the screen. (For details about I/O script files, refer to Chapter 7, "I/O Script Functions")
The following shows how to list.

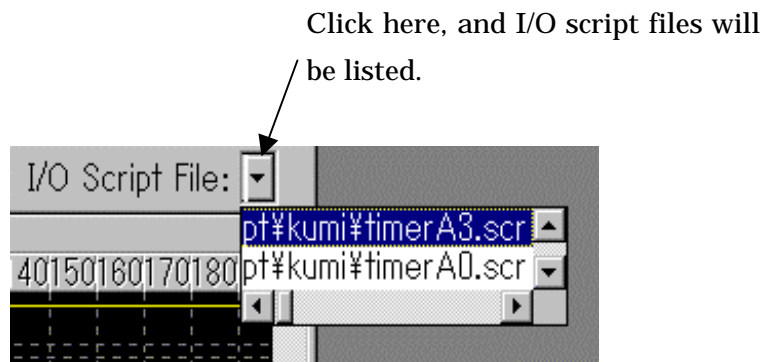

4.8 Regarding Evaluation Timings of Virtual Port Inputs, Virtual Interrupts, and I/O Script Files Set

The virtual port inputs, virtual interrupts, and I/O script files you've set are evaluated at the following timings:

Evaluation timings

- When program is executed (continuously); when come is executed
- When program is single-stepped
- When program is overstepped
- When control is returned

Processing when program is reset

The virtual port inputs, virtual interrupts, and I/O script files that you've set are reevaluated. Namely, when a program is reset, the virtual port inputs, virtual interrupts, and I/O script files you've set are set newly again.

Processing when I/O Window is closed

If the I/O Window is closed, the virtual port inputs, virtual interrupts, and I/O script files that you've set are not evaluated. This case is the same as when their settings have been deleted.

5 Setting GUI Input Window

5.1 Overview

The GUI Input Window allows you to create a simple key input panel (buttons) of the user target system in a window and execute virtual port inputs or virtual interrupts by pressing the buttons you've created.

Here, we'll explain how to create buttons.

5.2 Creating Buttons

Follow the procedure below to create buttons.

1. Choose the GUI Input Window menus [Option] -> [Make] (or the Make button).
2. Next, move the mouse cursor into the GUI Input Window's input panel display area, at which time the mouse cursor will have its shape changed to a cross (+).
3. While in this state, click the left mouse button at a position where you want a button to be created. Hold down the left mouse button while you move the mouse cursor to expand its size and release the left mouse button where the size is what you want.

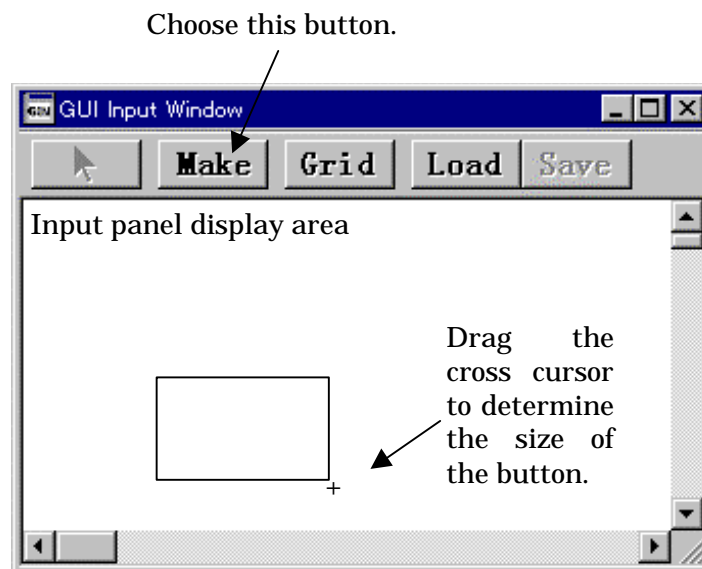

4. A button will be created as shown below.

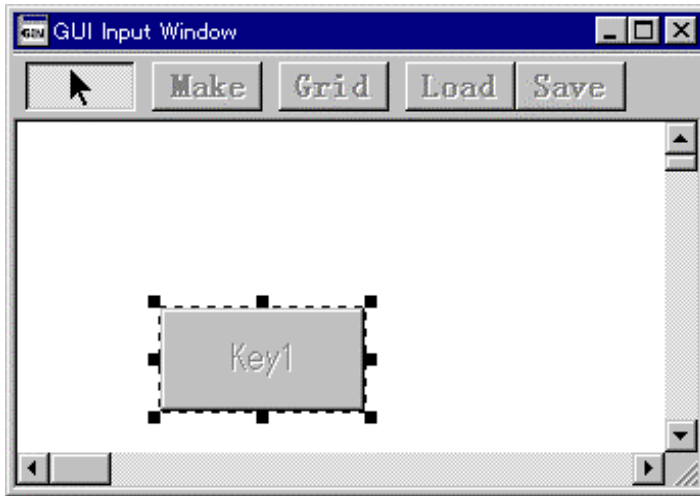

5. Next, double-click on the button you've created.

[CAUTION]

Before double-clicking on the button you've created, check to see that the arrow on the tool bar is selected. If not selected, choose the arrow before double-clicking on the button you've created.

6. A dialog box for setting the action to be performed by the button like the one shown below will appear. For this button action, set one of virtual port input, virtual interrupt, or virtual port input plus virtual interrupt.

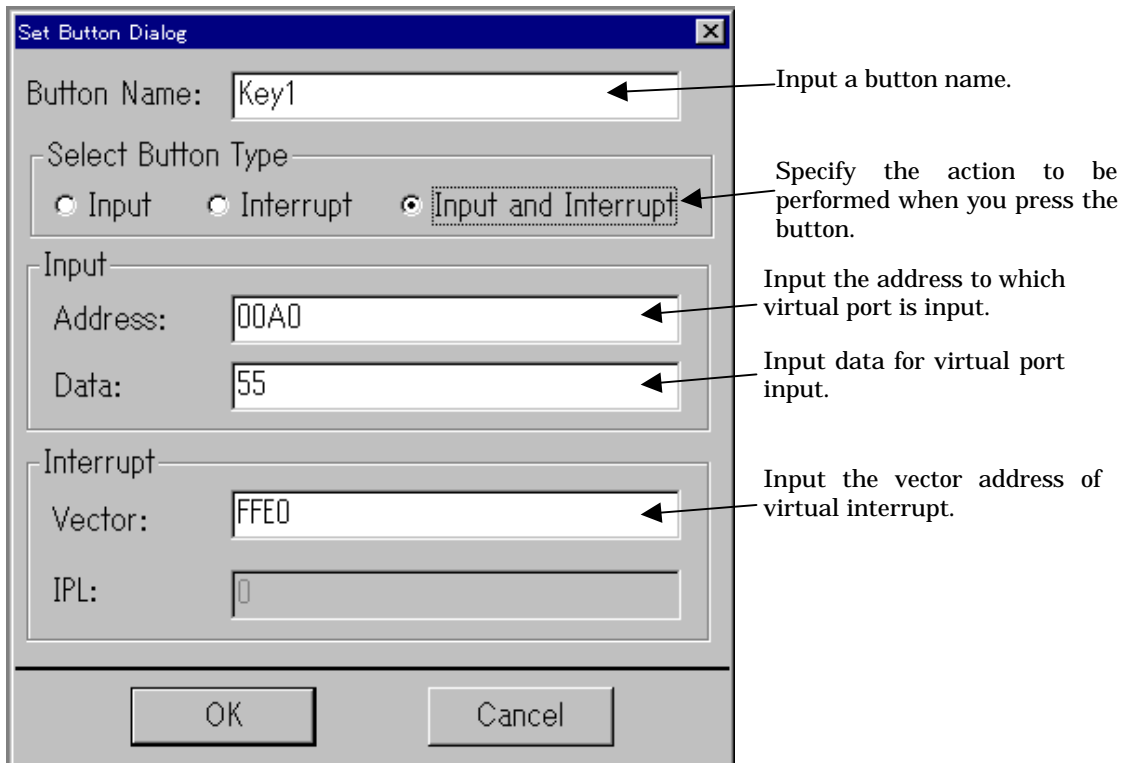

- (1) Assign the button a name. (Input your desired name in the Button Name column.)
- (2) Specify the action to be performed when you press the button in the Select Button Type column.
 - Choose Input for virtual port input.
 - Choose Interrupt for virtual interrupt.
 - Choose Input and interrupt for simultaneous generation of virtual port input and virtual interrupt.
- (3) If you've selected virtual port input, enter the address to which you want data to be input and the data to be input in the Input column.
If you've selected virtual interrupt, enter the vector address of the virtual interrupt in the Interrupt column.
7. Press the OK button in the dialog box. Thus, you've finished creating and setting a button.
8. To create another button, repeat steps 1 to 7 above.

5.3 Saving Buttons You've Created

When you've finished creating buttons, you can save the data (setup contents and layout) of the buttons you've created to a file (GUI input file). The saved GUI input file can be loaded into PD38SIM back again by using the menus [Option] -> [Load].

Follow the procedure below to save the button data.

Choose the GUI Input Window menus [Option] -> [Save] (or the Save button). When selected, the dialog box shown below will appear.

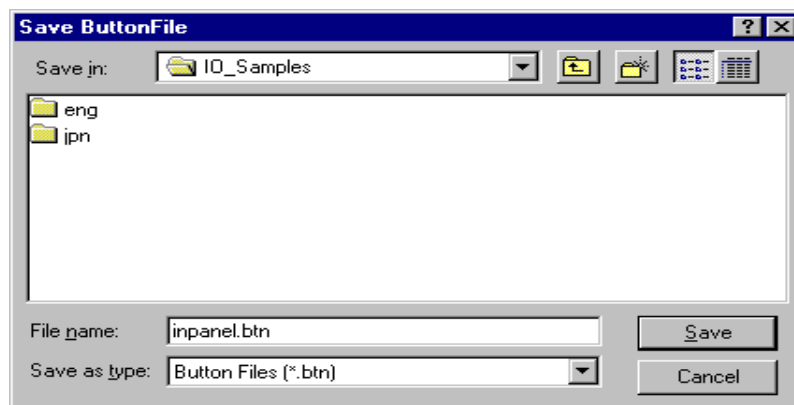

Here, enter the directory and file names in which you want the button data to be saved. When you've input a file name, press the Save button.

5.4 Changing Button Position or Settings after Creating Button

After creating buttons, you can change their positions or setup contents.

1. To change the position of a button

Choose the GUI Input Window menus [Option] -> [Set] (or the  button). Then point to the button whose position you want to be changed and click the left mouse button.

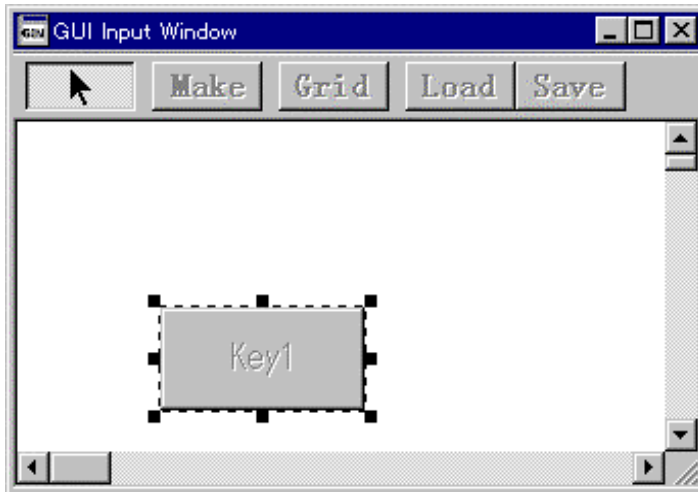

The button is placed in a selected state when you've clicked, as shown above. When in this state, hold down the left mouse button while you drag the button to a position where you want it.

2. To change the setup contents of a button

Choose the GUI Input Window menus [Option] -> [Set] (or the  button), as in 1 above. Then point to the button whose setup contents you want to be changed and double-click the left mouse button. The dialog box shown below will appear.

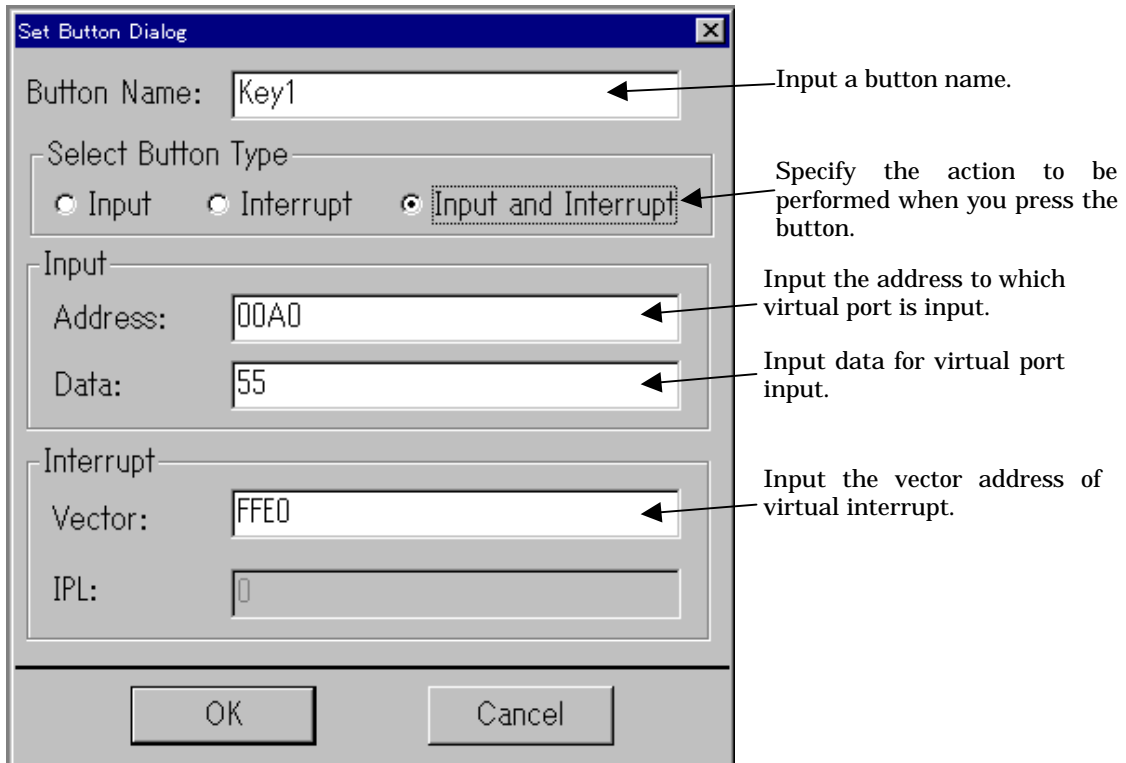

Here, change the setup contents of the selected button.

5.5 Copying buttons

Follow the procedure below to copy buttons.

1. Choose the GUI Input Window menus [Option] -> [Copy].
2. Next, move the mouse cursor into the GUI Input Window's input panel display area, at which time the mouse cursor will have its shape changed to a cross (+).
3. While in this state, point to the button you want to copy and click the left mouse button.
4. Next, choose the GUI Input Window menus [Option] -> [Paste]. A new button will be copied on to the button you've selected with the left mouse button.

Or choose the GUI Input Window menus [Option] -> [Set] (or the  button). After choosing the menu, point to the button you want to copy and click the left mouse button to select it. Then press the Ctrl + C key combination and Ctrl + V key combination.

5.6 Deleting buttons

Follow the procedure below to delete buttons.

1. Choose the GUI Input Window menus [Option] -> [Del].
2. Next, move the mouse cursor into the GUI Input Window's input panel display area, at which time the mouse cursor will have its shape changed to a cross (+).
3. While in this state, point to the button you want to delete and click the left mouse button.

Or choose the GUI Input Window menus [Option] -> [Set] (or the <- button). After choosing the menu, point to the button you want to delete and click the left mouse button to select it. Then press the Delete key.

5.7 Displaying Grid Lines

The GUI Input Window has a function to display grid lines at a position where buttons can be located. Use this function when you place buttons.

To display grid lines, choose the menus [Option] -> [Display Grid Line] (or the Grid button). When selected, grid lines like the one shown below are displayed.

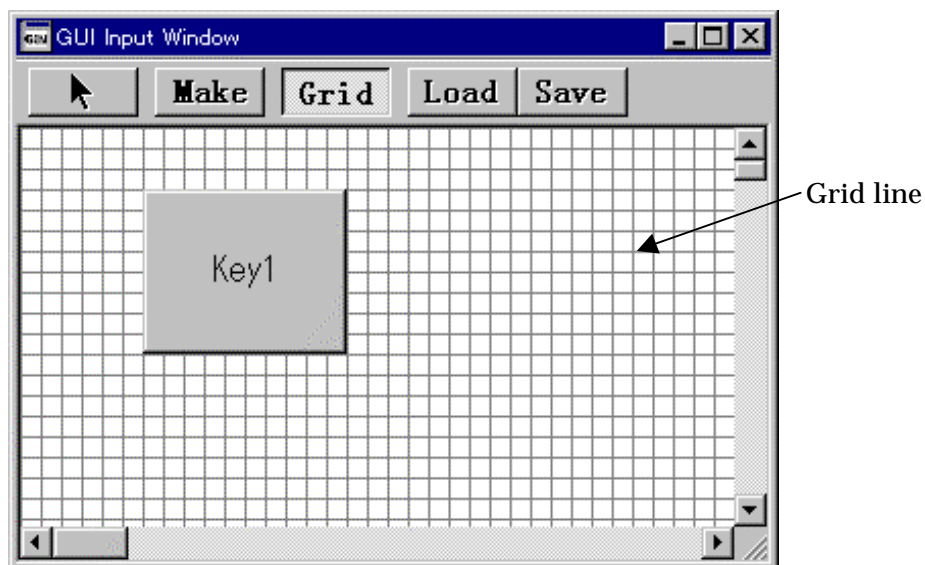

6 Setting GUI Output Window

6.1 Overview

The GUI Output Window allows you to implement the user target system's simple output panel in a window.

The following parts can be arranged in this output panel:

- Label (character string)
User-specified character strings are displayed or erased when some value is written to a specified memory address or according to logic 1 or 0 in a bit.
- LED
LEDs are lit when some value is written to a specified memory address or according to logic 1 or 0 in a bit.

Maximum number of parts that can be arranged

- The total number of addresses that can be set for the parts created is 20, including addresses of all parts. Therefore, if the addresses set for each part all are different, the maximum number of parts that can be arranged in the output panel is 20.
- If the number of addresses set for each part is less than 20, there is, in effect, no limit to the maximum number of parts that can be arranged.

The following explains how to create parts for the GUI Output Window.

6.2 Creating Labels

Follow the procedure below to create labels.

1. Choose the GUI Output Window menus [Option] -> [Make Label] (or the Label button).
2. Next, move the mouse cursor into the GUI Output Window's output panel display area, at which time the mouse cursor will have its shape changed to a cross (+).

3. While in this state, click the left mouse button at a position where you want to create a label. Hold down the left mouse button while you move the mouse cursor to expand its size and release the left mouse button where the size is what you want.

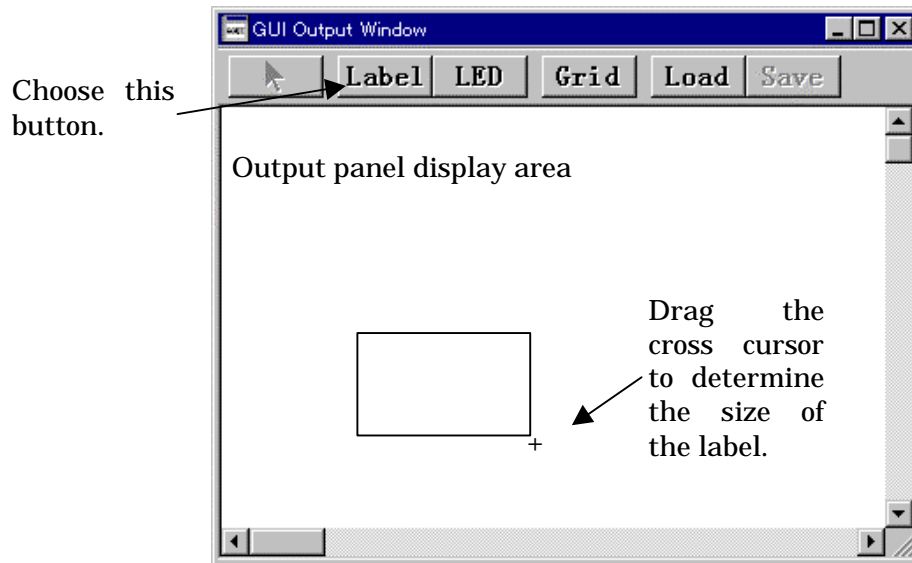

4. When a frame in which to display the label appears, double-click somewhere in the frame.

[CAUTION]

Before double-clicking on the label you've created, check to see that the arrow on the tool bar is selected. If not selected, choose the arrow before double-clicking on the label you've created.

5. A dialog box for setting a label like the one shown below will appear.
 Here, you can specify one of the following two methods for monitoring outputs:
- Display/erase a user-specified character string according to logic 1 or 0 in memory bit
 - Display/erase a character string when some value is written to memory

(1) For displaying/erasing a user-specified character string according to logic 1 or 0 in memory bit

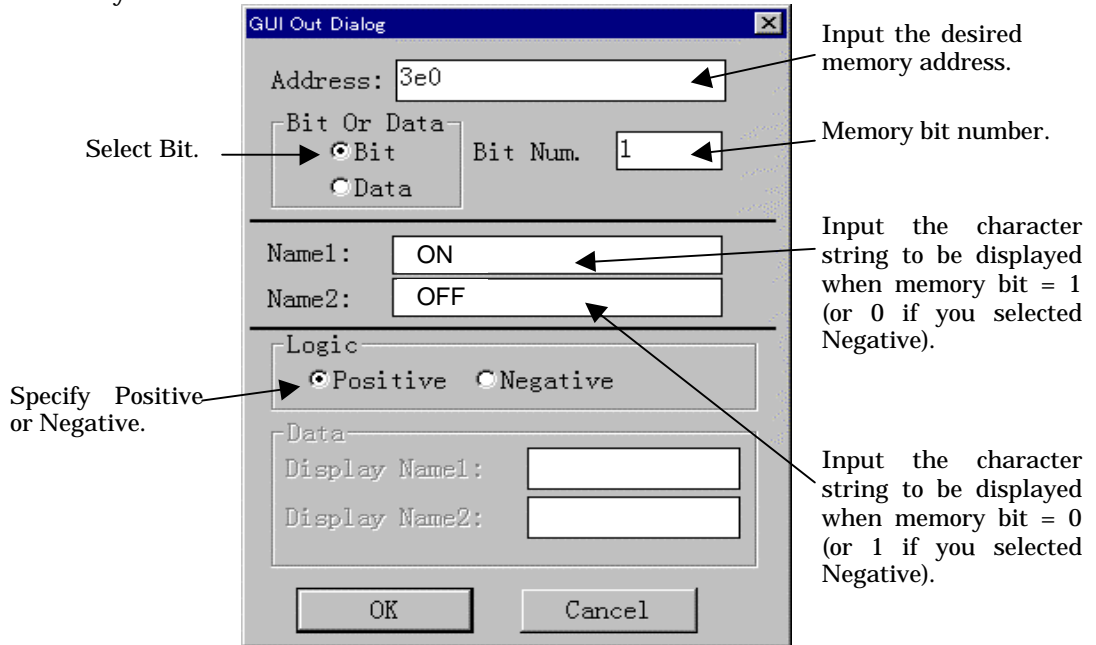

(2) For displaying/erasing a character string when some value is written to memory

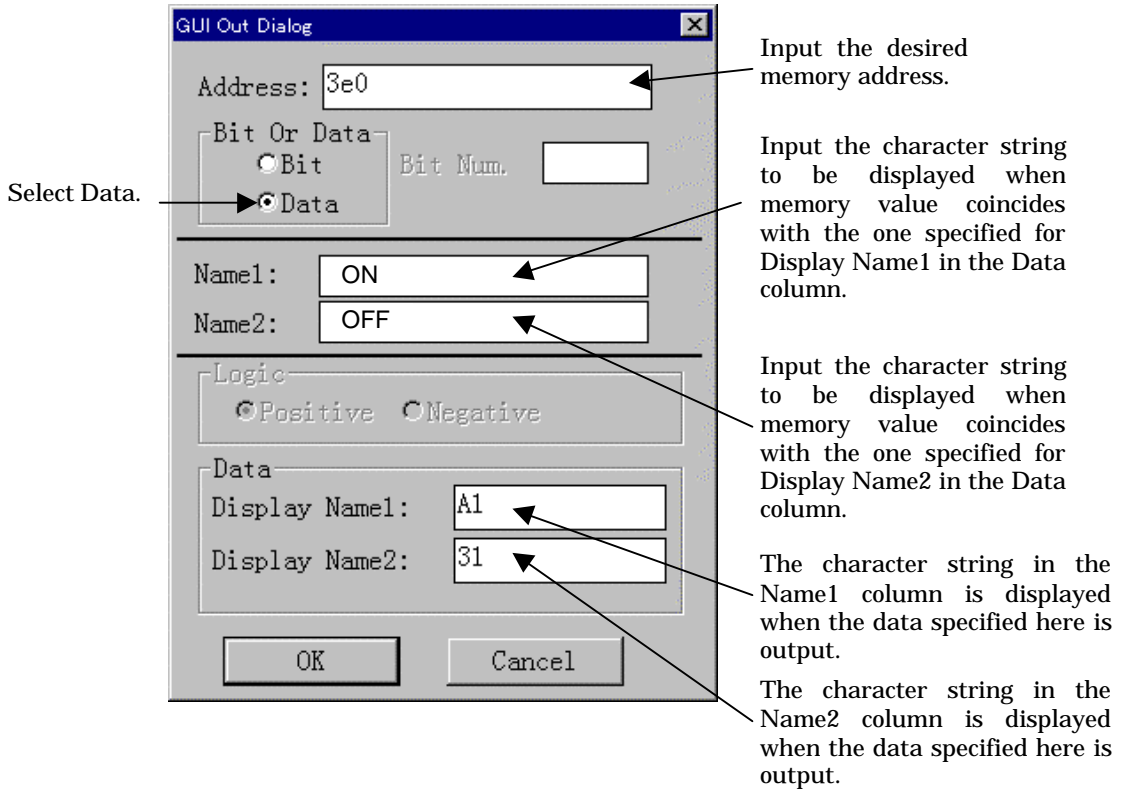

6. Press the OK button in the dialog box. Thus, you've finished creating and setting a label.
7. To create another label, repeat steps 1 to 6 described above.

6.3 Creating LEDs

Follow the procedure below to create LEDs.

1. Choose the GUI Output Window menus [Option] -> [Make LED] (or the LED button).
2. Next, move the mouse cursor into the GUI Output Window's output panel display area, at which time the mouse cursor will have its shape changed to a cross (+).
3. While in this state, click the left mouse button at a position where you want to create an LED. Hold down the left mouse button while you move the mouse cursor to expand its size and release the left mouse button where the size is what you want.

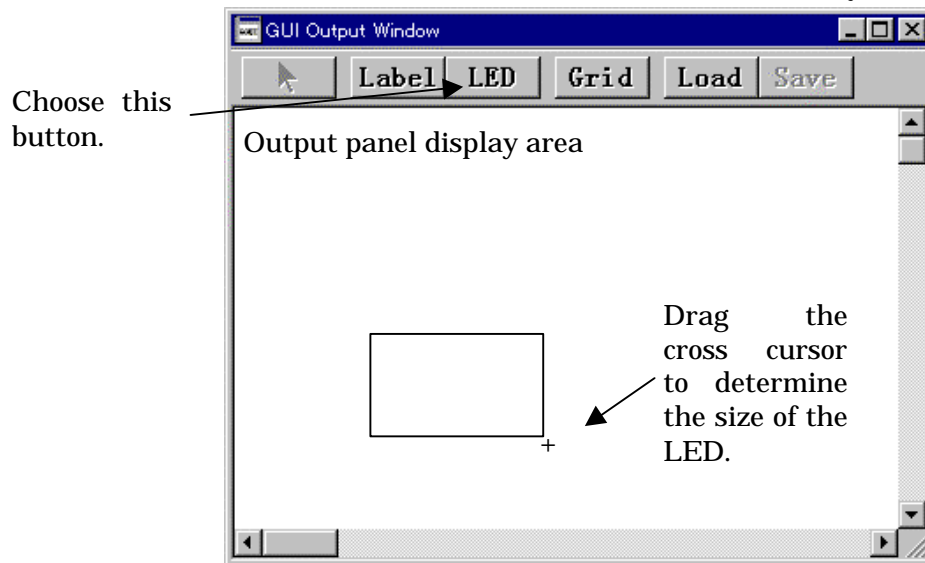

4. When a frame in which to display the LED appears, double-click somewhere in the frame.

[CAUTION]

Before double-clicking on the LED you've created, check to see that the arrow on the toolbar is selected. If not selected, choose the arrow before double-clicking on the LED you've created.

5. A dialog box for setting an LED like the one shown below will appear.
Here, you can specify one of the following two methods for monitoring outputs:
- Turn on LED according to logic 1 or 0 in memory bit
 - Turn on LED when some value is output to memory
- (1) For turning on LED according to logic 1 or 0 in memory bit

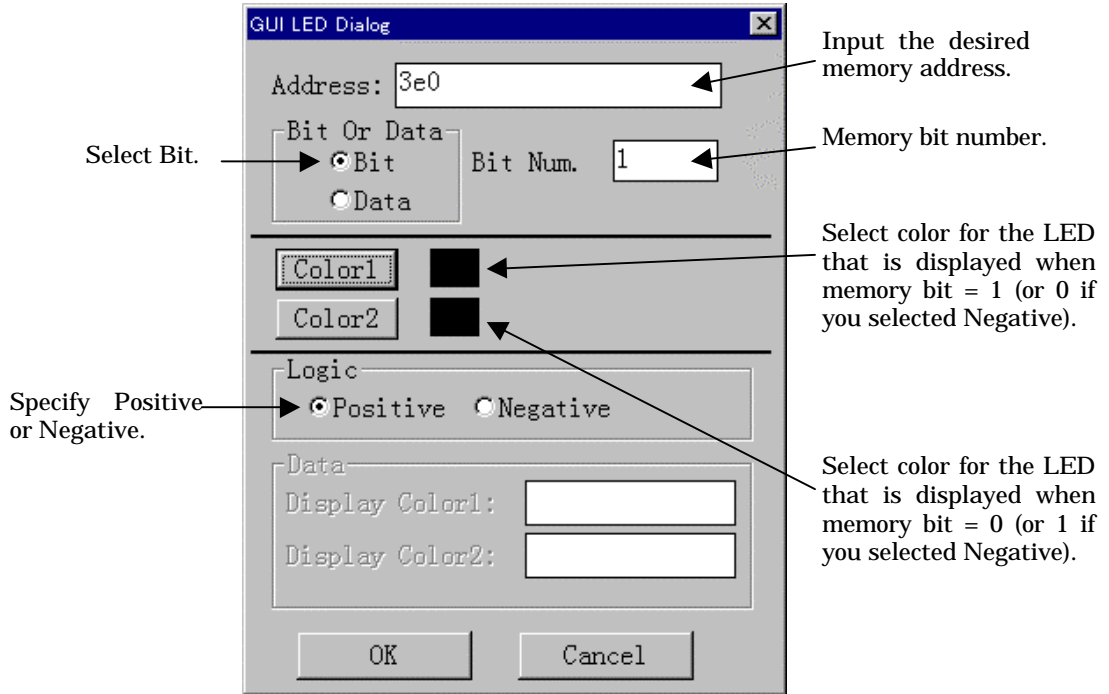

(2) For turning on LED when some value is output to memory

Input the desired memory address.

Select color for the LED that is displayed when memory value coincides with the one specified for Display Color1 in the Data column.

Select color for the LED that is displayed when memory value coincides with the one specified for Display Color2 in the Data column.

The LED is lit in the color selected in the Color1 column when the data specified here is output.

The LED is lit in the color selected in the Color2 column when the data specified here is output.

6. When you press the Color1 or Color2 button, a dialog box for selecting LED colors appears.

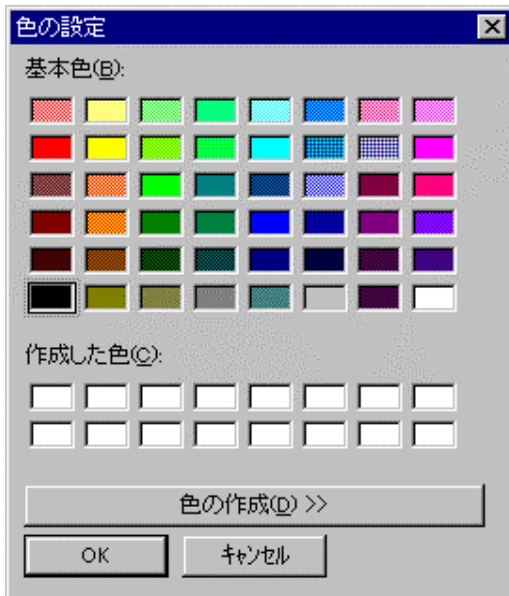

Here, choose colors in which you want the LEDs to be displayed and press the OK button.

7. Thus, you've finished creating and setting an LED.
8. To create another LED, repeat steps 1 to 7 described above.

6.4 Saving Parts You've Created

When you've finished creating parts, you can save the data (setup contents and layout) of the parts you've created to a file (GUI output file). The saved GUI output file can be loaded into PD38SIM back again by using the menus [Option] -> [Load] to reproduce the saved parts.

Follow the procedure below to save the parts data.

Choose the GUI Output Window menus [Option] -> [Save] (or the Save button). When selected, the dialog box shown below will appear.



Here, enter the directory and file names in which you want the parts data to be saved. When you've input a file name, press the Save button.

6.5 Changing Parts Position or Settings after Creating Parts

After creating parts, you can change their positions or setup contents.

1. To change the position of a part

Choose the GUI Output Window menus [Option] -> [Set] (or the  button). Then point to the part whose position you want to be changed and click the left mouse button.

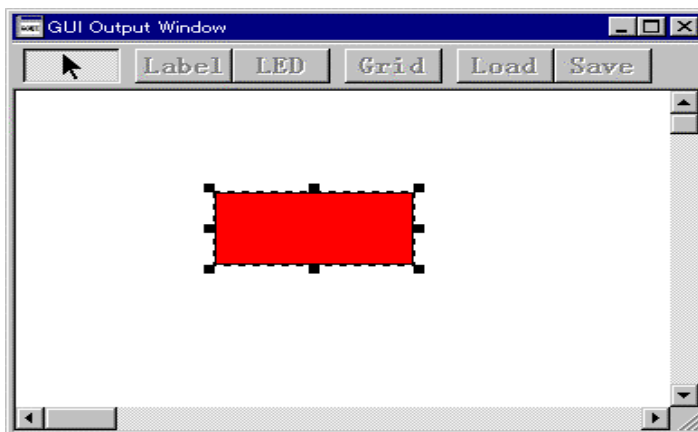

The button is placed in a selected state when you've clicked, as shown above. When in this state, hold down the left mouse button while you drag the part to a position where you want it.

2. To change the setup contents of a part
Choose the GUI Output Window menus [Option] -> [Set] (or the  button), as in 1 above. Then point to the part whose setup contents you want to be changed and double-click the left mouse button.

The dialog box you've used when creating parts will appear. Use this dialog box to change the settings of the selected part.

6.6 Copying Parts

Follow the procedure below to copy parts.

1. Choose the GUI Output Window menus [Option] -> [Copy].
2. Next, move the mouse cursor into the GUI Output Window's output panel display area, at which time the mouse cursor will have its shape changed to a cross (+).
3. While in this state, point to the part you want to copy and click the left mouse button.
4. Next, choose the GUI Input Window menus [Option] -> [Paste]. A new part will be copied on to the part you've selected with the left mouse button.

Or choose the GUI Output Window menus [Option] -> [Set] (or the  button). After choosing the menu, point to the button you want to copy and click the left mouse button to select it. Then press the Ctrl + C key combination and Ctrl + V key combination.

6.7 Deleting Parts

Follow the procedure below to delete parts.

1. Choose the GUI Output Window menus [Option] -> [Del].
2. Next, move the mouse cursor into the GUI Output Window's output panel display area, at which time the mouse cursor will have its shape changed to a cross (+).
3. While in this state, point to the part you want to delete and click the left mouse button.

Or choose the GUI Output Window menus [Option] -> [Set] (or the  button). After choosing the menu, point to the part you want to delete and click the left mouse button to select it. Then press the Delete key.

6.8 Displaying Grid Lines

The GUI Output Window has a function to display grid lines at a position where parts can be located. Use this function when you place parts.

To display grid lines, choose the menu [Option] -> [Display Grid Line] (or the Grid button). When selected, grid lines like the one shown below are displayed.

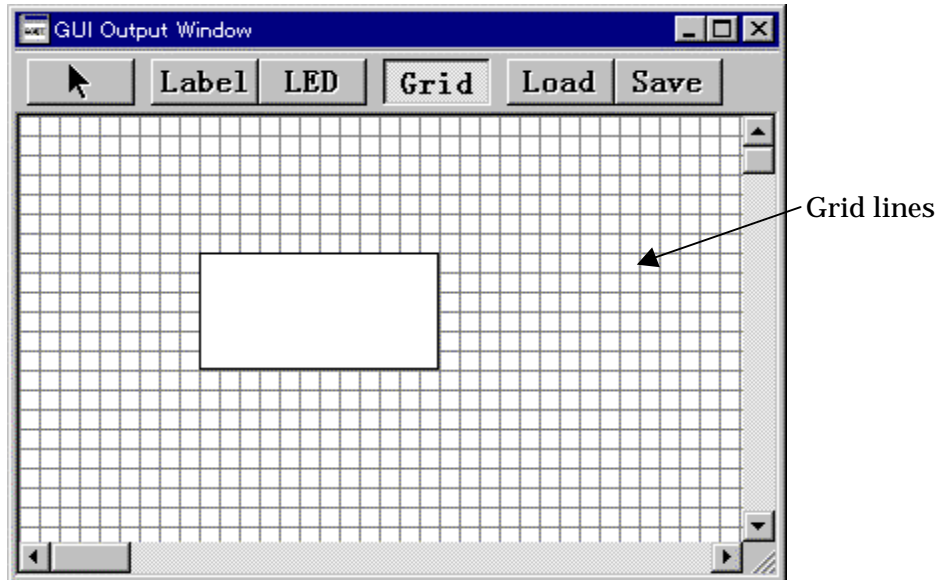

7 I/O Script Function

7.1 Overview

Settings of virtual port inputs or virtual interrupts can be written to a file in script form. This script is called the "I/O script." Also, the files that contain a description of I/O scripts are called the "I/O script file."

Using I/O scripts, you can set virtual port inputs and virtual interrupts in a more flexible manner than can be set from the I/O Window. For example, you can make the following settings that cannot be made from the I/O Window:

- If you want to generate a cyclic virtual interrupt like timer interrupts, you can use the while statement to specify a repetition of virtual interrupt generation.
- You can specify that the priority levels set in the interrupt control register's interrupt priority level select bits be referenced to resolve the interrupt priority of virtual interrupts generated.
- As conditions for entering virtual port inputs or generating virtual interrupts, you can specify a combination of program fetch, memory access for read/write, or memory comparison.

In addition to the above, various other I/O settings are possible.

7.2 Method for Writing I/O Script

This section explains the method for defining virtual port inputs, virtual interrupts, and other I/Os to be written in I/O script by using definition examples.

To define an I/O script, write a procedure for it. Enclose a procedure with braces "{ }" as you write it. Multiple procedures can be written in one file.

In each procedure, write settings, timings, etc. of virtual port inputs or virtual interrupts.

Each of the multiple procedures thus defined are processed in parallel with program execution. However, the order in which each procedure is evaluated is indeterminate.

Register the I/O script file you've created in PD38SIM using the I/O Window menus [Option] -> [Load] (or the Load button). Multiple I/O script files can be registered. However, the total number of procedures that can be registered is limited to 20.

- Procedure 1 in the example below defines the timer mode of timer 1. In this example, a timer 1 interrupt is generated every divide-by-ratio (number of cycles) specified for the timer 1.
- Procedure 2 in the example below defines a cycle-synchronized virtual port input. In this example, data is input from virtual port to memory when the program has been executed 10,000 cycles. Although the I/O Window supports virtual port inputs in only bytes, I/O scripts allow for virtual port inputs in words.

<code>; Definition example of I/O script file</code>	<code>-> Comment statement.</code>
<code>; Definition of procedure 1 (example for virtual interrupt)</code>	<code>-> Beginning of procedure 1.</code>
<code>{</code>	<code>-> while statement.</code>
<code> while(1){</code>	<code>-> Keeps execution of I/O script waiting for the number of cycles equal to the divide-by-ratio that is set for timer1.</code>
<code> waitc [0x0021] + 1</code>	
<code> int 0xFFEE</code>	<code>-> Generates a timer 1 virtual interrupt.</code>
<code> }</code>	
<code>}</code>	<code>-> Terminates procedure 1.</code>

<code>; Definition of procedure 2 (example for virtual port input)</code>	<code>-> Beginning of procedure 2.</code>
<code>{</code>	<code>-> Keeps execution of I/O script waiting for 10,000 cycles.</code>
<code> waitc 10000</code>	<code>-> Inputs 0x20 in address 0x0.</code>
<code> set [0x0] = 0x20</code>	
<code> waitc 10000</code>	
<code> set [0x0] = 0x30</code>	<code>-> Inputs 1-byte data 0x30 from address 0x0.</code>
<code>}</code>	<code>-> Terminates procedure 2.</code>

7.3 Composition of I/O Script

Following statements can be written in I/O script:

- Procedure
- I/O script statement
- Judgment (if, else)
Execution statements are branched off by judging the evaluation result of expression.
- Repeat statement (while) and Break statement
Statements are executed repeatedly by judging the evaluation result of expression.
- Comment statement
Comments can be written in I/O script. Comment statements are ignored when executing I/O script.

When creating I/O scripts, write one statement in one line. You cannot write multiple statements in one line or one statement in multiple lines.

7.3.1 Procedure

Procedures specify a definition block of an I/O script. Multiple procedures can be written in one file. However, the number of procedures that can be defined is limited to 20. (If procedures are defined in multiple files, this limit means that up to 20 of such procedures can be defined.) The following shows a description format.

```
{
  Statements
}

{
  Statements
}

In the same way, multiple procedures can be defined below.
:
```

7.3.2 I/O Script Statements

Following five statements can be used in I/O script:

(1) **waiti statement**

Format: waiti number of machine instructions

Function:

Execution of the next statement is kept waiting for a specified number of machine instructions.

Right-side expressions can be used to specify the number of machine instructions. (Specification of right-side expressions is described later.)

For example, if following statements are written

```
waiti 100
set [0x800] = 0x10
```

the set statement is executed only after executing 100 machine instructions.

(2) **waitc statement**

Format: waitc number of cycles

Function:

Execution of the next statement is kept waiting for a specified number of cycles.

Right-side expressions can be used to specify the number of cycles. (Specification of right-side expressions is described later.)

For example, if following statements are written

```
waitc 10000
set [0x800] = 0x10
```

the set statement is executed only after executing the program 10,000 cycles.

(3) **int statement**

Format: int vector address

Function:

The virtual interrupt of a specified vector address is generated.
Right-side expressions can be used to specify the vector address.

(Specification of right-side expressions is described later.)

For example, if following statements are written

int 0xffec

a timer 2 (vector address 0xffec) interrupt is generated.

(4) **set statement**

There are following three formats for the set statement:

Format 1: set memory address = input value

Function:

The input value is input to a specified memory address (virtual port input to memory).

Left-side expressions can be used to specify the memory address, and right-side expressions can be used to specify the input value. (Specifications of left-side and right-side expressions are described later.)

For example, if following statements are written

set [0x2] = 0x1d

data 0x1d is input to memory address 0x2.

Format 2: set condition expression, memory address = input value 1, input value 2, ...

Function:

The input value 1, input value 2, etc. are sequentially input to a specified memory address each time the conditional expression is established.

Left-side expressions can be used to specify the memory address, and right-side expressions can be used to specify the conditional expressions and input values. (Specifications of left-side and right-side expressions are described later.)

For example, if following statements are written

set #isfetch:0xf000 , [0x3] = 0x10 , 0x20

; #isfetch becomes true (established) when the program executes a specified address.

data 0x10 and 0x20 are sequentially input to memory address 0x3 each time the program executes address 0xf000.

Namely, data 0x10 is input to memory address 0x3 when address 0xf000 is executed first, and data 0x20 is input when the address is executed next.

Format 3: set % macro variable = right-side expression

Function:

The right-side expression is placed in a specified macro variable. (Specification of macro variables is described later.)

For example, following macro variables can be written:

set %val = 10; Macro variable val is initialized to 10.

set %val = %val + 1; Value of the macro variable is incremented by 1.

(5) **pass statement****Format:** pass conditional expression, pass count**Function:**

Execution of the next statement is skipped a number of times as specified by the pass count until the conditional expression is met.

Right-side expressions can be used to specify the conditional statement and pass count. (Specification of right-side expressions is described later.)

For example, if following statements are written

```
pass #isint:0xffec
```

```
; #isint becomes true (established) when a specified virtual interrupt is
generated.
```

```
set [0x800] = 0x10
```

The set statement is executed only after a timer 2 interrupt (vector address 0xffec) occurs three times.

7.3.3 Judge Statements (if, else)

Judge statements judge the results of expressions, thereby causing the statements to be executed to branch off. The following shows a description format.

```
if (conditional expression) {
    Statement 1
} else if (conditional expression) {
    Statement 2
} else {
    Statement 3
}
```

- When if (conditional expression) is true (not 0) statement 1 is executed. If the conditional expression is false (= 0), else if (conditional expression) is evaluated to see whether it is true or false. If the conditional expression is true, statement 2 is executed. Otherwise, statement 3, the else statement, is executed.
- The else if and else statements can be omitted.
- The if statement can be nested in up to 32 levels.
- Right-side expressions can be used for the conditional expression.
- The conditional expressions written in I/O script are calculated as unsigned type. Therefore, if negative values are compared in an if statement, the operation to be performed by PD38SIM is indeterminate.

7.3.4 Repeat Statement (while) and break Statement

Repeat statements judge the results of expressions, thereby executing statements repeatedly. The following shows a description format.

```
while (conditional expression) {
    statement or break statement
}
```

- If the conditional expression is true, the statement is executed repeatedly. If the conditional expression is false, program execution exits from the loop.
- The while statement can be nested in up to 32 levels.
- A break statement is used if it is necessary to forcibly exit the while statement. If the while statement is nested, program execution exits from the innermost loop.
- Right-side expressions can be used for the conditional expression.

- The conditional expressions written in I/O script are calculated as unsigned type. Therefore, if negative values are compared in an while statement, the operation to be performed by PD38SIM is indeterminate.

7.3.5 Comment Statements

Comment statements are used to write comments in I/O script. The following shows a description format.

```
; character string
```

- A comment statement starts from a semicolon (;).
- A range of statement from the semicolon (;) till the end of the line is handled as a comment.
- Lines of comment statements are ignored when executing I/O scripts.

7.4 Method for Writing Right-side Expressions

Right-side expressions can be used to write the number of machine instructions or cycles, vector address, input values, conditional expressions, or pass counts in I/O script statements, as well as write expressions in if and while statements. The following shows an example of an I/O script statement written using right-side expressions.

```
waitc LABEL
waiti [0x800] + 20
if( [0x1ff] == 0x30 )
while( #isfetch:0xf000 )
```

7.4.1 Composition of Right-side Expressions

Right-side expressions may be composed of the following:

- Constant
- Symbol and label
- Macro variable
- Memory variable
- Character constant
- Operator
- #isfetch, #isint, #isread, #iswrite

Each part of right-side expressions are described below.

7.4.2 Constants

Binary, decimal, and hexadecimal numbers can be input. The radix of numerals is discriminated by a symbol added at the beginning or end of a numeric value.

	Hexadecimal	Decimal	Binary
Beginning	0x,0X	None	%
Example	0xAB24	1234	%10010

7.4.3 Symbols and Labels

The global symbols and global labels defined in the target program can be used.

- Symbol and label names may consist of alphanumeric characters, underscore (`_`), period (`.`), and question mark (`?`). However, numbers cannot be used at the beginning of symbol and label names.
- Symbol and label names can be written in up to 255 characters.
- Symbol and label names are discriminated between uppercase and lowercase letters.
- The structured instructions, pseudo-instructions, macro-instructions, and reserved op-code words of assembler sra74 cannot be used in symbol and label names. (These, for example, include `.SECTION`, `.BYTE`, `switch`, and `if`.)
- Character strings that begin with `..` cannot be used in symbol and label names.

7.4.4 Macro Variables

Macro variables are used by adding `"%"` at the beginning of each variable name.

- Variable names following the percent character (`%`) may consist of alphanumeric characters and underscore (`_`). However, numbers cannot be used at the beginning of macro variable names.
- Register names cannot be used in variable names.
- Variable names are discriminated between uppercase and lowercase letters.
- Up to 32 macro variables can be defined. Once defined, the macro variables remain effective until PD38SIM is terminated.

7.4.5 Memory Variables

Memory variables are used when using memory values in expressions. The following shows a format of memory variables.

[address].data-size

- Expressions can be written in address. (Memory variables also can be used.)
- Specify data size as shown in the table below.

For byte size	B or b
For word (2-byte) size	W or w

- If specification of data size is omitted, the data size is assumed to be byte long.
Example 1: To reference memory contents at address 8000_{16} in bytes
[0x8000].B or [0x8000]
Example 2: To reference memory contents at address 8000_{16} in words
[0x8000].w

7.4.6 Character Constants

Specified characters or character strings are handled as constants after being converted into ASCII code.

- Characters must be enclosed with single quotations.
- Character strings must be enclosed with double quotations.
- Character strings must be within 2 characters (16 bits in length).
 If a character string consists of more than two characters, only the last two characters written in the string are operated on. For example, if you write "ABCD," only the last two characters in this string, i.e., "CD," are operated on, the value of which is 4344₁₆.

7.4.7 Operators

The following lists the operators that can be written in expressions.

- The priorities of operators are such that level 1 is the highest, and level 12, the lowest. If operators in an expression have the same priority, they are calculated sequentially from left to right.

Operator	Meaning	Priority
()	Parentheses	Level 1
+, -, ~	Unary plus, unary minus, unary logical negation	Level 2
*, /	Binary multiplication, binary division	Level 3
+, -	Binary addition, binary subtraction	Level 4
>>, <<	Shift right, shift left	Level 5
<, <=, >, >=	Binary comparison	Level 6
==, !=	Binary comparison	Level 7
&	Binary logical AND	Level 8
^	Binary exclusive OR	Level 9
	Binary logical OR	Level 10
&&	Logical AND	Level 11
	Logical OR	Level 12

7.4.8 #isfetch, #isint, #isread, #iswrite

These statements are used in conditional expressions of I/O script statements and if and while statements.

(1) **#isfetch expression**

Format: #isfetch: address

Function:

The value of the expression becomes true (= 1) when the program's PC value goes to a specified address. Otherwise, the expression is false (= 0).

For example, the if statement below

if (#isfetch:0xfc00)

becomes true (= 1) when the program's address (PC value) becomes 0xfc00.

(2) #isint expression**Format:** #isint: vector address**Function:**

The value of the expression becomes true (= 1) immediately after a virtual interrupt of a specified vector address is generated. Otherwise, the expression is false (= 0).

For example, the if statement below

```
if ( #isint:0xffe)
```

becomes true (= 1) if a virtual interrupt of vector address 0xffe had occurred immediately before the if statement was evaluated.

(3) #isread expression**Format:** #isread: address**Function:**

The value of the expression becomes true (= 1) immediately after a specified memory address is accessed for read (to read data from memory). Otherwise, the expression is false (= 0).

For example, the if statement below

```
if ( #isread:0x800)
```

becomes true (= 1) if memory at address 0x800 had been accessed for read immediately before the if statement was evaluated.

(4) #iswrite expression**Format:** #iswrite: address**Function:**

The value of the expression becomes true (= 1) immediately after a specified memory address is accessed for write (to write data to memory). Otherwise, the expression is false (= 0).

For example, the if statement below

```
if ( #iswrite:0x800)
```

becomes true (= 1) if memory at address 0x800 had been accessed for write immediately before the if statement was evaluated.

7.5 Method for Writing Left-side Expressions

Left-side expressions can be written in memory addresses and macro variables of the set statement in I/O script statements. The following shows an example of an I/O script statement using left-side expressions.

```
set [0x2] = 0x1a
set %val = 10
```

7.5.1 Composition of Left-side Expressions

Left-side expressions may be composed of the following:

- Macro variable
- Memory variable

Each part of left-side expressions are described below.

7.5.2 Macro Variables

Macro variables are used by adding "%" at the beginning of each variable name.

- Variable names following the percent character (%) may consist of alphanumeric characters and underscore (_). However, numbers cannot be used at the beginning of macro variable names.
- The values that can be handled by an expression that is substituted for macro variables are integers in the range of 0 to FFFFFFFF₁₆. If negative numbers are used, they are handled as 2's complements.

When specifying a repeat count for the while statement, use of macro variables should prove convenient.

```

set %val = 0 ; Macro variable %val is assigned 0.
while(%val < 10){ ; while statement is repeated until %val = 10.
    waitc 10000
    int 0xffe
    set %val = %val + 1 ; %val is incremented by 1.
}
    
```

7.5.3 Memory Variables

This variable is used when writing values in memory. The following shows a format of memory variables.

[address].data-size

- Expressions can be written in address. (Memory variables cannot be used.)
- Specify data size as shown in the table below.

For byte size	B or b
For word (2-byte) size	W or w

- If specification of data size is omitted, the data size is assumed to be byte long.
 Example 1: When writing to memory at address 0x8000 in bytes
 set [0x8000].B = 0x10 or set [0x8000] = 0x10
 Example 2: When writing to memory at address 0x8000 in words
 set [0x8000].w = 0x1234

8 Coverage Information

8.1 Referencing Coverage

To reference the coverage (C0 coverage) of each function in the downloaded C language program, open the coverage window. The coverage window can be opened by selecting the following from the PD38SIM window menu.

[Window] -> [Coverage Window]

Coverage window for checking the execution rate of each function

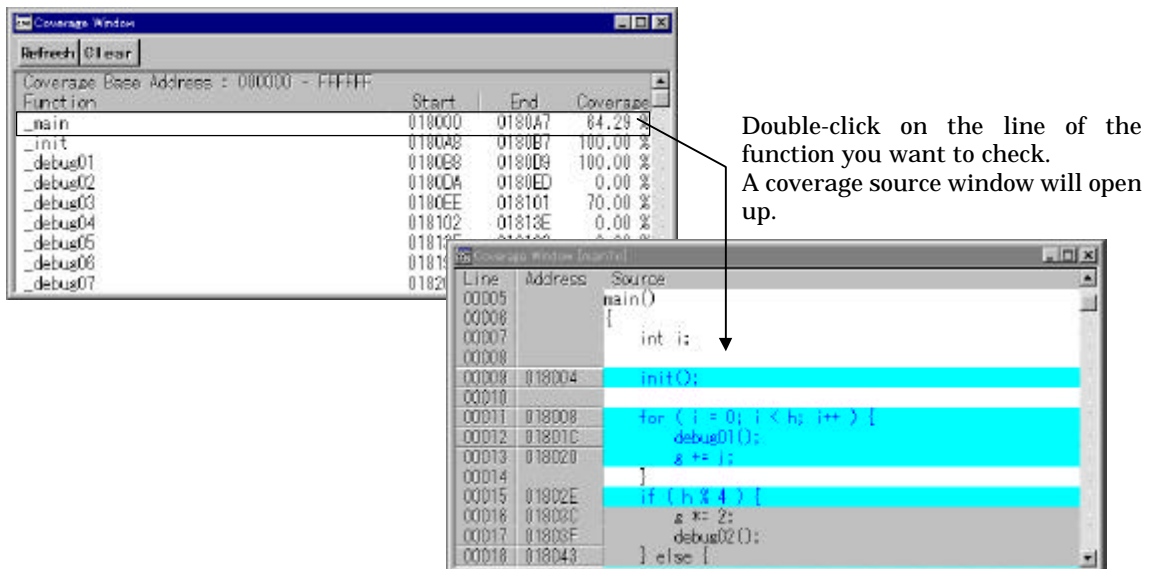

Coverage source window for checking for each line whether the

8.2 Updating Coverage Display

When the target program is executed using a GO or STEP command, the coverage display area of the coverage window changes to '-'. The display is not automatically updated. If you want to update it, press the Refresh button on the toolbar (or select [Option] -> [Refresh] from the menu).

The display of the coverage source window is automatically updated when the program has stopped.

8.3 Initializing Coverage

To initialize the coverage measurement information, press the Clear button on the toolbar (or select [Option] -> [Clear] from the menu). All coverage figures are cleared to 0%.

8.4 Saving/Loading Coverage Measurement Information

The coverage measurement information can be saved to a file and the saved information can be loaded from a file into the computer. In this way, measurement can be started immediately following the previous one.

To save coverage measurement information

To save coverage information, select the following from the PD38SIM window menu when the coverage window is active.

[Option] -> [File] -> [Save...]

A coverage save dialog box will appear when the above are selected from the menu.

- A path can be added to the file name that is specified here.
- If a file name extension is omitted, the default file extension ".cov" is added.
- If an existing file name is specified for the file name here, the file will be overwritten.
- A file selection dialog box appears when you click on the <Refer> button. A file name can be specified in this dialog box also.
- The coverage information is saved to the specified file when you click <OK>.

To load coverage measurement information

To load data from a file that contains the coverage measurement results saved by the "Save" menu command into the computer, select the following from the PD38SIM window menu when the coverage window is active.

[Option] -> [File] -> [Load...]

A file selection dialog box will appear when the above are selected from the menu.

- When the file is loaded into the computer, the coverage RAM base address is automatically changed to one that was the base address when saved.
- A path can be added to the file name that is specified here.
- If a file name extension is omitted, the default file extension ".cov" is added.
- After entering a file name (or single-clicking on it in the file list), press the <Open> button or double-click on the file name in the file list. Coverage information will be loaded from the specified file into the computer.

9 Customize Function

9.1 About Customize Function

The Customize Function allows you to add your own original functions to PD38SIM. By loading custom command and custom window programs to PD38SIM, you can extend the standard functions of PD38SIM.

To create custom command and custom window programs...

A special software called "CB38SIM (Custom Builder for PD38SIM)" is included with PD38SIM. Use it to create custom command and custom window programs. The custom command and custom window programs created with CB38SIM can be made available to use by registering them to PD38SIM using a MACRO command. For details on how to create custom command and custom window programs, refer to the "CB38SIM User's Manual.

To use custom window programs...

There are two methods to show in the following to use the custom window made with CB38SIM.

- Register the custom window in the menu, and open from the menu.
- Register the custom window with the MACRO command, and open with the MACRO command

Show the way of registering to the menu in the following.

Refer to the following "To use custom command and custom window programs..." for the registration with the MACRO command and the open.

How to register for the menu

To register the custom window in the menu, select the following from the PD38SIM Window menu:

[Optional Window] -> [Custom Window] -> [Option...]

Then, the following dialog opens.

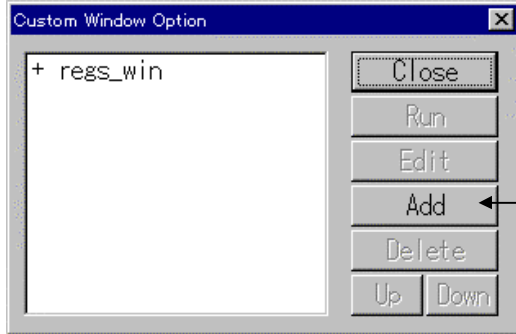

1 Open the custom window registration dialog

Custom window launcher dialog

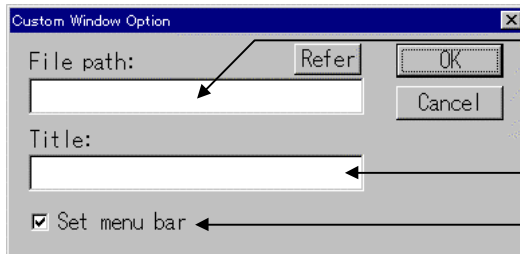

2. Input the program file name (with the extension ".p") of the custom window with absolute pass.

3. Input the title of menu.

4. Choose display / non-display to the menu.

5. Click **OK** button

Custom window registration dialog

The change of contents of registration

To change contents of registration, open the custom window registration dialog with the following process. Then, change contents of registration.

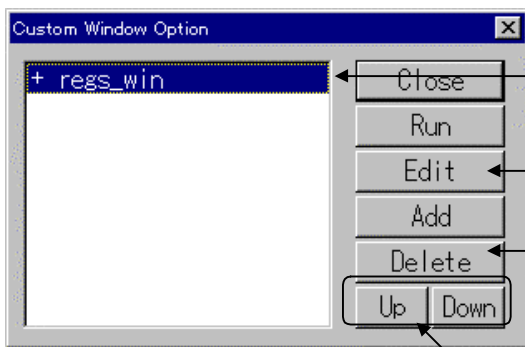

1. Select the custom window which changes contents of registration.

2. Open the custom window registration dialog

Click the **Delete** button to remove registration.

Change the turn of the display of the menu.

The open of custom window

The menu to open the custom window when it is registered is added.

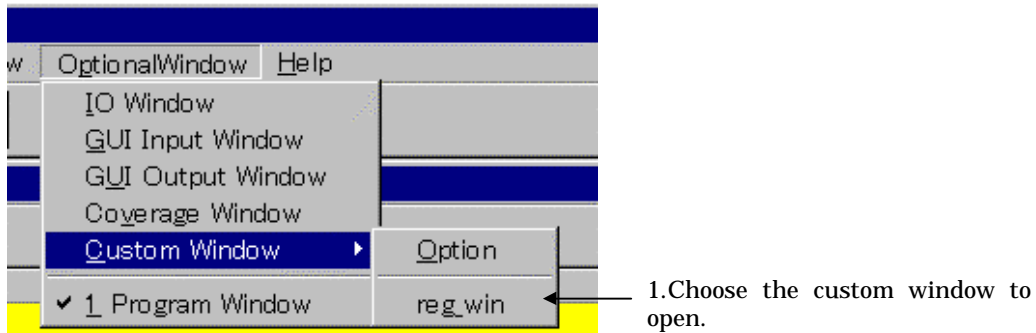

The custom window can be opened when the custom window is chosen with the custom window launcher dialog and it clicks on the Run button.

To use custom command and custom window programs...

Register the custom command and custom window programs created with CB38SIM from the Script Window using a MACRO command. Specify as the parameter the custom command and custom window program file names (with the extension ".p" omitted) when registering the programs to PD38SIM. This makes the programs usable.

Example: >MACRO custom<RET>

For the custom command and custom window programs registered to PD38SIM by a MACRO command, you can execute the program and open the window using the same procedure as used to execute a script command. To execute the program registered by a MACRO command, use its file name as the command name as shown below.

Example: >custom<RET>

The custom command and custom window programs registered by a MACRO command remain intact until they are deleted from PD38SIM by a DELMACRO or DELMACROALL command. (They are retained even when you quit PD38SIM.)

To find the custom command or custom window program thus registered, PD38SIM searches its current directory (one that has been set by a script command CD). If these programs are stored in some other directory, specify that directory according to an explanation of the search directory in the later section of this manual.

To delete custom command and custom window programs...

To delete the custom command and custom window programs registered to PD38SIM by a MACRO command, use a DELMACRO command by specifying the registered file name of the program (not including the extension) in it or a DELMACROALL command. When using a DELMACRO command, only the specified custom command or custom window program is deleted. When using a DELMACROALL command, all of the registered custom command and custom window programs are deleted.

Example: >DELMACRO custom<RET>
>DELMACROALL<RET>

To set the search directory of custom command and custom window programs...

The custom command and custom window programs registered by a MACRO command are loaded into PD38SIM when they are executed. The custom command and custom window programs to be loaded are searched for from the directory that has been set by a MACROPATH (MPATH) command. Only one directory can be specified by a MACROPATH (MPATH) command.

Example: >MACROPATH c:¥usr¥project¥custom<RET>

The open of custom window

The menu to open the custom window when it is registered is added.

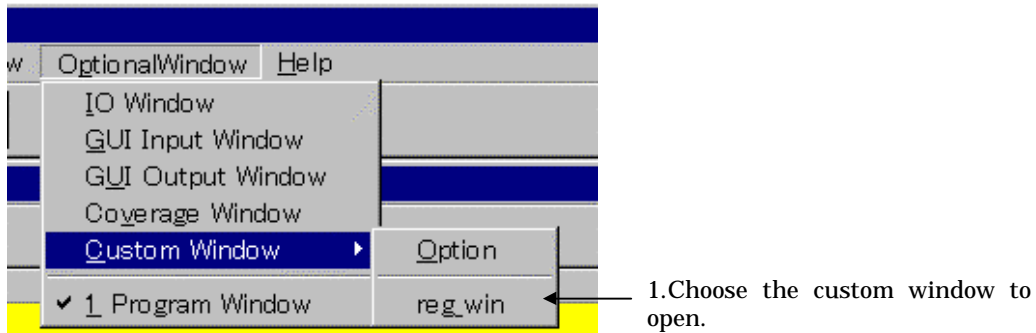

The custom window can be opened when the custom window is chosen with the custom window launcher dialog and it clicks on the Run button.

To use custom command and custom window programs...

Register the custom command and custom window programs created with CB38SIM from the Script Window using a MACRO command. Specify as the parameter the custom command and custom window program file names (with the extension ".p" omitted) when registering the programs to PD38SIM. This makes the programs usable.

Example: >MACRO custom<RET>

For the custom command and custom window programs registered to PD38SIM by a MACRO command, you can execute the program and open the window using the same procedure as used to execute a script command. To execute the program registered by a MACRO command, use its file name as the command name as shown below.

Example: >custom<RET>

The custom command and custom window programs registered by a MACRO command remain intact until they are deleted from PD38SIM by a DELMACRO or DELMACROALL command. (They are retained even when you quit PD38SIM.)

To find the custom command or custom window program thus registered, PD38SIM searches its current directory (one that has been set by a script command CD). If these programs are stored in some other directory, specify that directory according to an explanation of the search directory in the later section of this manual.

To delete custom command and custom window programs...

To delete the custom command and custom window programs registered to PD38SIM by a MACRO command, use a DELMACRO command by specifying the registered file name of the program (not including the extension) in it or a DELMACROALL command. When using a DELMACRO command, only the specified custom command or custom window program is deleted. When using a DELMACROALL command, all of the registered custom command and custom window programs are deleted.

Example: >DELMACRO custom<RET>
>DELMACROALL<RET>

To set the search directory of custom command and custom window programs...

The custom command and custom window programs registered by a MACRO command are loaded into PD38SIM when they are executed. The custom command and custom window programs to be loaded are searched for from the directory that has been set by a MACROPATH (MPATH) command. Only one directory can be specified by a MACROPATH (MPATH) command.

Example: >MACROPATH c:¥usr¥project¥custom<RET>

Reference

1 Table of Script Commands

1.1 Input Format

- The format for entering PD38SIM script commands is as follows:
 1. Insert one or more spaces or tabs between the command and its parameter(s).
 2. You can use uppercase and lowercase letters and numerics for the command.
- Description of symbols used in command format

Parameter	Command format
XXXX	XXXX must be input
[XXXX]	XXXX is optional
{ X1 X2 X3 }	One of X1, X2, or X3 must be input
[{ X1 X2 X3 }]	Input can be omitted, or you can input one of X1, X2, or X3

1.2 Tables of Commands

In the following tables of commands, commands shown with half-tone screening can be executed at run time.

The abbreviated forms of commands are shown in parenthesis after the full command.

See the PD38SIM on-line help for details of each command. To display on-line help, enter the following from the PD38SIM Window menu:

[Help] -> [Index]

1.2.1 Execution Commands

Command	Command format	Summary
Go(G)	Go [start address]	Run target program.
GoFree(GF)	GoFree [start address]	Free-run target program.
STOP	STOP	Stop target program.
STATUS	STATUS	Display status of target program execution.
Step(S)	Step [number of steps]	Step execution at source level.
StepInstruction(SI)	StepInstruction [number of steps]	Step execution at machine language level.
OverStep(O)	OverStep [number of steps]	Over-step execution at source level.
OverStepInstruction (OI)	OverStepInstruction [number of steps]	Over-step execution at machine language level.
RETurn(RET)	RETurn	Return execution at source level.
RETurnInstruction(RETl)	RETurnInstruction	Return execution at machine language level.
RESET	RESET	Reset target program.

1.2.2 File Operation Commands

Command	Command format	Summary
Load(L)	Load Filename [.hex .sym]	Download HEX/SYM file.
LoadHex(LH)	LoadHex Filename [.hex]	Download HEX file.
LoadIe(LE)	LoadIe Filename [.695]	Download 695 file.
LoadSymbol(LS)	LoadSymbol Filename [.695 .sym]	Download debugging information.
UploadHex(UH)	UploadHex start address,end address,filename	Output contents of specified memory area to hex file.

1.2.3 Register Operation Commands

Command	Command format	Summary
Register(R)	(1)Register [register name] (2)Register register name, set value	(1) Check value of specified register. (2) Set value of specified register.

1.2.4 Memory Operation Commands

Command	Command format	Summary
DumpByte(DB)	DumpByte [start address [.end address]]	Display contents of memory in 1-byte units.
SetMemoryByte(MB)	setMemoryByte address [,set value [, ...]]	Change contents of memory at specified address in 1-byte units. Enter "." to stop.
FillByte(FB)	FillByte start address,end address,aet value	Write specified data to specified address range in 1-byte units.
MOVE	MOVE start address1,end address, start address2	Move contents of specified memory range to destination address.
MOVEWord(MOVEW)	MOVEWord start address1,end address, start address2	Move contents of specified memory range to destination address in 2-byte units..

1.2.5 RAM Monitor Commands

Command	Command format	Summary
RRAM	(1) RRAM (2) RRAM SET, Address (3) RRAM CLEAR	(1)Checks the RAM monitor area. (2)Sets the RAM monitor area to the specified address. (3)Initializes the access state of the RAM monitor area.

1.2.6 Assemble/Disassemble Commands

Command	Command format	Summary
Assemble(A)	Assemble [address]	Assemble line-by-line from specified address.
DisAssemble(DA)	DisAssemble [start address [,end address]]	Display result of disassembling specified area.
MODule(MOD)	MODule	Display all modules (object names).
SCOPE	(1) SCOPE (2) SCOPE module name	(1) Display current scope. (2) Set scope to specified module.
SECTion(SEC)	SECTION	Display section information.
BIT	(1) BIT (2) BIT { GLOBAL G } , Bitsymbol [, Data] (3) BIT { LOCAL L } , Bitsymbol , Data	(1) Display all bit symbols. (2) Set value of bit showed by specified global bit symbol. (3) Set value of bit showed by specified local bit symbol.
SYMBOL(SYM)	(1) SYMBOL (2) SYMBOL { GLOBAL G } [, symbol] (3) SYMBOL { LOCAL L } [, symbol]	(1) Display all symbols. (2) Display global symbols. (3) Display local symbols.
EXPRESS(EXP)	EXPRESS assembler expression	Display value of specified assembler expression.

1.2.7 Software Break Setting Commands

Command	Command format	Summary
SoftwareBreak(SB)	(1) SoftwareBreak (2) SoftwareBreak address	(1)Display currently set software break points. (2)Set software break point at specified address.
SoftwareBreakClear(SBC)	SoftwareBreakClear address	Delete software break point at specified address.
SoftwareBreakClearAll (SBCA)	SoftwareBreakClearAll	Delete all software break points.
SoftwareBreakDisable (SBD)	SoftwareBreakDisable address	Disable software break point at specified address.
SoftwareBreakDisableAll (SBDA)	SoftwareBreakDisableAll	Disable all software break points.
SoftwareBreakEnable (SBE)	SoftwareBreakEnable Address	Enable software break point at specified address.
SoftwareBreakEnableAll (SBEA)	SoftwareBreakEnableAll	Enable all software break points.
BREAKAT	BREAKAT line No. [,source filename]	Set software break point at specified line No.
BREAKIN	BREAKIN function name [,module name]	Set software break point at start of specified function.

1.2.8 Hardware Break Setting Commands

Command	Command format	Summary
HardwareBreak(HB)	(1) HardwareBreak (2) HardwareBreak address, { READ WRITE RW FETCH } [, [passes] [, [{ BYTE }]], reference-data [, comparison-condition]]]]	(1) Reference hardware break point. (2) Set hardware break point. See "Supplementation explanation of Script Commands" for details.
HardwareBreakClear (HBC)	HardwareBreakClear address	Clears hardware break point at specified address.
HardwareBreakClearAll (HBCA)	HardwareBreakClearAll	Clears all hardware break points.
BreakMode(BM)	(1) BreakMode (2) BreakMode { ON OFF }	(1) Check hardware break mode. (2) Set hardware break mode.

1.2.9 Coverage Measurement Commands

Command	Command format	Summary
CoVerage(CV)	(1)Coverage (2)Coverage LOCAL [, start address, end address] (3)Coverage GLOBAL [, start address, end address] (4) Coverage TOTAL [, start address, end address] (5) Coverage FUNC (6) Coverage CLEAR (7) Coverage DISP, starting address for displaying	(1) Check starting address for displaying the results of coverage measurements. (2) Display results of coverage measurements in 1-byte units. (3) Display results of coverage measurements in 4-byte units. (4) Display results of coverage measurements as percentages. (5) Display results of coverage measurements of sub-routines as percentages. (6) Initialize memory for coverage measurements. (7) Set starting address for displaying the results of coverage measurements. See "Supplementation explanation of Script Commands" for details.

1.2.10 StackMonitor Command

Command	Command format	Summary
StackMonitor(SM)	(1) StackMonitor (2) StackMonitor { ON OFF }	(1) Checks the stack monitor mode. (2) Turns the stack monitor on/off.

1.2.11 Cycle Count Command

Command	Command format	Summary
CYcle(CY)	(1) CYcle (2) CYcle { ON OFF }	(1) Checks the cycle count mode. CYCLE OFF: The number of total execution cycles is displayed. CYCLE ON: The number of accumulation execution cycles from the CYCLE ON specification is displayed. (2) Turns the cycle count on/off.

1.2.12 Script/Log-File Commands

Command	Command format	Summary
<i>SCRIPT</i>	SCRIPT filename	Open script file.
<i>EXIT</i>	EXIT	Close script file.
WAIT	WAIT [BREAK]	Wait for command input until target program stops.
<i>PAUSE</i>	PAUSE "MESSAGE"	Display specified message in Pause dialog box and wait for user to press button.
<i>SLEEP</i>	SLEEP number of seconds	Wait for command input for specified number of seconds.
<i>LOGON</i>	LOGON [Filename [.file attribute]]	Open log file.
<i>LOGOFF</i>	LOGOFF	Close log file.

1.2.13 Program Window Control Commands

Command	Command format	Summary
<i>PATH</i>	PATH [search pass [;search pass ;....]]	Set source file path.
<i>FILE</i>	(1) FILE (2) FILE source filename	(1) List source files. (2) Display specified source file.

1.2.14C-Language Debugging Commands

Command	Command format	Summary
PRINT	PRINT variable expression	Check value of specified C variable expression.
SET	SET variable expression, value	Set specified data in specified C variable expression.

1.2.15 Custom Command Program/Custom Window Program

Command	Command format	Summary
<i>MACRO</i>	(1)MACRO (2)MACRO custom command's programname/ custom window's program	(1)Reference a list of added custom command and custom window programs. (2)Add a specified custom command and custom window program.
<i>DELMACRO</i>	DELMACRO custom command's programname/ custom window's program	Delete a specified custom command and custom window program.
<i>DELMACROALL</i>	DELMACROALL	Delete all specified custom command and custom window programs.
<i>MACROPATH(MPATH)</i>	(1)MACROPATH (2)MACROPATH directory_name	(1)Reference the search directory that is set. (2)Set the directory where to search for custom command and custom window programs.

1.2.16 Utility Commands

Command	Command format	Summary
<i>RADIX</i>	(1) RADIX (2) RADIX { 2 8 10 16 }	(1) Check radix for input of constants. (2) Set radix for input of constants.
<i>ALIAS</i>	(1) ALIAS (2) ALIAS new name , command name	(1) Check definition of command alias. (2) Define command alias.
<i>UNALIAS</i>	UNALIAS new name	Delete specified alias.
<i>UNALIASALL</i>	UNALIASALL	Delete all aliases.
<i>VERsion(VER)</i>	VERsion	Display PD38SIM versions.
<i>DATE</i>	DATE	Display current date and time (yymmdd, and time).
<i>ECHO</i>	ECHO "MESSAGE"	Display specified parameter.
<i>QUIT</i>	QUIT	Quit PD38SIM.
<i>CD</i>	(1) CD (2) CD directory_name	(1) Checks the current directory. (2) Sets the current directory.

1.2.17 Supplementation explanation of Script Commands

HardwareBreak(HB)

Setting and Checking Hardware Breaks

Input format

- Format 1: HardwareBreak
- Format 2: HardwareBreak address, FETCH [, passes]
- Format 3: HardwareBreak address, access-condition [, passes]
- Format 4: HardwareBreak address, access-condition, [passes], size
- Format 5: HardwareBreak address, access-condition, [passes], [size]
, reference-data [, Comparison-condition]

The following table shows the values that can be specified for access-condition, size, and comparison condition.

Access-condition	READ, R, WRITE, W, RW
size	BYTE, B
Comparison-condition	<, >, <=, >=, !=, ==

Function:

- Hardware breaks allow you to stop target program execution on detection of data being read from or written to memory or on detection of an instruction fetch.
- PD38SIM allows a maximum of 64 hardware breakpoints to be set.
- To use hardware breaks, use the BreakMode command as shown below to enable the break.

BreakMode ON

Checking hardware break settings

Use format 1. Enter the following to display the contents of the hardware break setting.

HardwareBreak

Stopping program execution on execution of the instruction at the specified address

Use format 2.

- Enter the following to stop execution of the target program on execution of the instruction at address 8000₁₆.

HardwareBreak 8000, FETCH

- Enter the following to stop execution of the target program on 10th execution of the instruction at address 8000₁₆.

HardwareBreak 8000, FETCH, 10

If not specified, the default number of passes is 1. (This also applies to other formats.)

Stopping program execution when data at the specified address is accessed

Use formats 3, 4, or 5. The following table shows the differences between the respective formats.

Format 3	Use to stop program execution regardless of the value of the accessed data.
Format 4	Use to stop program execution according to the size of the accessed data.
Format 5	Use to stop program execution according to the accessed data.

- Enter the following to stop program execution when any data is written to address 30₁₆ (format 3).

HardwareBreak 30, WRITE

You can abbreviate WRITE to W. Specify READ or R to stop program execution when data is read, or RW when data is read or written.

- Enter the following to stop execution when 1 bytes of data is written to address 30₁₆ (format 4):

HardwareBreak 30, WRITE, , BYTE

You can abbreviate BYTE to B.

If not specified, the default size is BYTE. (This also applies to other formats.)

- Enter the following to stop program execution when a value of 50₁₆ is written to 30₁₆ (format 5).

HardwareBreak 30, WRITE, , , 50

As with other formats, '=' is assumed if data is specified for comparison but no condition is specified. (This also applies to other formats.)

- Enter the following to stop program execution when a value of 50₁₆ or more is written to 30₁₆ (format 5).

HardwareBreak 30, WRITE, , , 50, >=

CoVerage(CV)

Coverage Measurement

Use the coverage measuring function to check addresses accessed during execution. The coverage measurement function is realized using the CoVerage (CV) script command. For details of using script commands, see Section 7.1, "Executing Script Commands" in the Basic Operation part.

Input format:

Format 1: CoVerage

Format 2: CoVerage { LOCAL | GLOBAL | TOTAL }, starting_address, ending_address]

Format 3: CoVerage FUNC

Format 4: CoVerage CLEAR

Format 5: CoVerage DISP, starting address for displaying the results of coverage

Function:

- The coverage function records addresses that have been accessed during execution of the target program (CO coverage).

To run coverage measurement and log access details

Run the target program. See Section 2.1, "Starting and Stopping" in the Basic Operation for details.

To check accessed addresses

Use formats 2 and 3. You can check addresses from 0000₁₆ to FFFF₁₆.

- Enter the following to check the results of coverage measurements between address 8000₁₆ and 8FFF₁₆ in 1-byte units (format 2):
CoVerage LOCAL, 8000, 8FFF
- Enter the following to check the results of coverage measurements between address 8000₁₆ and 8FFF₁₆ in 4-byte units (format 2):
CoVerage GLOBAL, 8000, 8FFF
- Enter the following to check the results of coverage measurements between address 8000₁₆ and 8FFF₁₆ displayed as a percentage (format 2):
CoVerage TOTAL, 8000, 8FFF
- Enter the following to check the results of coverage measurements displayed as percentages of subroutines (functions) (format 3):
CoVerage FUNC

To initialize the previous results of coverage measurements

Use format 4.

- Enter the following to initialize the results of coverage measurements:
CoVerage CLEAR

To check and set the starting address for displaying the results of coverage measurements

Use format 1 or format 5. If you omit the starting or ending address when checking the results of coverage measurements, the system displays 1KB of results from the display starting address.

- Enter the following to check the display starting address for the results of coverage measurements:

CoVerage

- Enter the following to specify address C000₁₆ as the starting address for displaying the results of coverage measurements.

CoVerage DISP, C000

If, without specifying a starting or ending address, you check the results of coverage measurements after setting the display starting address to C000₁₆, the display extends from C000₁₆ to C400₁₆.

2 Writing Script Files

PD38SIM allows you to run script files in a Script Window. The script file contains the controls necessary for automatically executing the script commands.

2.1 Structural Elements of a Script File

You can include the following in script files:

- Script commands
- Assign statements
- Conditional statements (if, else, endi)
Program execution branches to the statement(s) to be executed according to the result of the conditional expression.
- Loop statements (while, endw)
A block of one or more statements is repeatedly executed according to the expression.
- break statement
Exits from the innermost loop.
- Comment statements
You can include comments in a script file. The comment statements are ignored when the script commands are executed.

Specify only one statement on each line of the script file. You cannot specify more than one statement on a line, or write statements that span two or more lines.

2.1.1 Script Commands

You can use the same script commands that you enter in the Script Window. You can also call script files from within other script files (nesting up to 5 levels).

2.1.2 Assign Statements

Assign statements define and initialize macro variables and assign values. The following shows the format to be used.

```
% macro-variable = expression
```

- You can use alphanumerics and the underscore (`_`) in macro variable names. However, you cannot use a numeric to start a macro variable name.
- You can specify any expression of which the value is an integer between `016` and `FFFFFFFF16` to be assigned in a macro variable. If you specify a negative number, it is processed as twos complement.
- You can use macro variables within the expression.
- Always precede macro variables with the "%" sign.

2.1.3 Conditional Statements (if, endi, else)

In a conditional statement, different statements are executed according to whether the condition is true or false. The following shows the format to be used.

```
if ( expression )
    statement 1
else
    statement 2
endi
```

- If the expression is true (other than 0), statement 1 is executed. If false, (0), statement 2 is executed.
- You can omit the else statement. If omitted and the expression is false, execution jumps to the line after the endi statement.
- if statements can be nested (up to 32 levels).

2.1.4 Loop Statements (while, endw) and Break Statement

In loop statements, execution of a group of statements is repeated while the expression is true. The following shows the format to be used.

```
while ( expression )
    statement
endw
```

- If the expression is true, the group of statements is repeated. If false, the loop is exited (and the statement following the endw statement is executed).
- You can nest while statements up to 32 levels.
- Use the break statement to forcibly exit a while loop. If while statements are nested, break exits from the innermost loop.

2.1.5 Comment statements

You can include comments in a script file. Use the following format.

```
; character string
```

- Write the statement after a semicolon (;). You can include only spaces and tabs in front of the semicolon.
- Lines with comment statements are ignored when the script file is executed.

Notes:

- You cannot include comments on the same lines as script commands.
- You can nest script files up to five levels.
- You can nest if statements and while statements up to 32 levels.
- If statements must be paired with `endif` statements, and while statements with `endw` statements in each script file.
- Expressions included in script files are evaluated as unsigned types. Therefore, operation cannot be guaranteed if you use negative values for comparison in if or while statements.
- You can specify up to 4096 characters per line. An error occurs if a line exceeds this number of characters.
- When a script file containing illegal commands is automatically executed (when you select [Option] -> [Script] -> [Run] from the Script Window menu after opening a script file, or click the <Run> button in the Script Window), execution of the script file continues even after the error is detected, except when the script line itself cannot be read.
If an error is detected and the script file continues to be executed, operation after detection of the error cannot be guaranteed. Reliability cannot therefore be placed on the results of execution after an error has been detected.

2.2 Writing Expressions

PD38SIM allows you to use expressions for specifying addresses, data, and number of passes, etc. The following shows example commands using expressions.

```
>DB TABLE1  
>DB TABLE1+20
```

2.2.1 Elements of Expressions

You can use the following elements in expressions:

- Constants
- Symbols and labels
- Macro variables
- Register variables
- Memory variables
- Line Nos.
- Character constants
- Operators

The following describes the respective elements.

2.2.2 Constants

You can use binary, octal, decimal, or hexadecimals. The prefix or suffix symbol attached to the numerical value indicates which radix is used.

	Hexadecimal	Decimal	Octal	Binary ¹
Prefix	0x,0X	@	None	%
Suffix	h,H	None	o,O	b,B
Examples	0xAB24 AB24h	@1234	1234o	%10010 10010b

¹ You can only specify % when the predetermined radix is hexadecimal.

- If you are inputting a radix that matches the predetermined radix, you can omit the symbol that indicates the radix (excluding binary).
- Use the RADIX command to set the predetermined value of a radix. However, in the cases shown below, the radix is fixed regardless of what you specify in a RADIX command.

Type	Radix
Address	Hex
Line No. No. of executions No. of passes No. of limits	Dec

2.2.3 Symbols and labels

You can include symbols and labels defined in your target program, or symbols and labels defined using the Assemble command.

- You can include alphanumerics, the underscore (_), period (.), and question mark (?) in symbols and labels. However, do not start with a numeric.
- Symbols and labels can consist of up to 255 characters.
- Uppercase and lowercase letters are unique.
- You cannot include the assembler sra74 structured instructions, pseudo instructions, macro instructions, operation code, or reserved words (.SECTION, .BYTE, switch, if, etc.).
- You cannot use strings that start with two periods (..) for symbols or labels.

Note 1: Local label symbol and scope

PD38SIM supports both global label symbols, which can be referenced from the whole program area, and local label symbols, which can only be referenced within the file in which they are declared.

The effective range of local label symbols is known as the scope, which is measured in units of object files (files with the ".r74" attribute). The scope is switched in PD38SIM in the following circumstances:

- When a command is entered
The object file that includes the address indicated by the program counter becomes the current scope. When the SCOPE command is used to set the scope, the specified scope is the active scope.

- During command execution
The current scope automatically switches depending on the program address being handled by the command.

Note 2: Priority levels of labels and symbols

The conversion of values to labels or symbols, and vice versa, is subject to the following levels of priority:

- Conversion of address values
 1. Local labels
 2. Global labels
 3. Local symbols
 4. Global symbols
 5. Local labels outside current scope
 6. Local symbols outside current scope
- Conversion of data values
 1. Local symbols
 2. Global symbols
 3. Local labels
 4. Global labels
 5. Local symbols outside current scope
 6. Local labels outside current scope
- Conversion of bit values
 1. Local bit symbols
 2. Global bit symbols
 3. Local bit symbols outside current scope

2.2.4 Macro Variables

Macro variables are defined by assign statements in the script file. See Section 2.1, "Structural Elements of a Script File" in the Reference part for details.

Precede variables with '%' for use as macro variables.

- You can specify alphanumerics and/or the underbar (`_`) in the variable name following the percent sign (%). However, do not start the names with a numeric.
- You cannot use the names of registers as variable names.
- Uppercase and lowercase letters are differentiated in variable names.
- You can define a maximum of 32 macro variables. Once defined, a macro variable remains valid until you quit PD38SIM.

Macro variables are useful for specifying the number of iterations of the while statement.

2.2.5 Register variables

Register variables are used for using the values of registers in an expression. Precede the name of the register with '_' to use it as a register variable. Use the following format.

%register-name

You can use the following registers.

A, X, Y, S, PC, F

Uppercase and lowercase letters are not unique in register names. You can specify either.

2.2.6 Memory variables

Use memory variables to use memory values in expressions. The format is as follows:

[address] .data-size

- You can specify expressions in addresses (you can also specify memory variables).
- The data size is specified as shown in the following table.

Byte length:	B or b
Word (2-byte) length:	W or w

- The default data size is word, if not specified.
 Example 1: Referencing the contents of memory at address 8000₁₆ in bytes
 [8000h] .B
 Example 2: Referencing the contents of memory at address 8000₁₆ in words
 [8000h] .W

2.2.7 Line Nos.

These are source file line Nos. The format for line Nos. is as follows:

#line_no
#line_no."source file name"

- Specify line Nos. in decimal.
- You can only specify line Nos. in which software breaks can be set.
 You cannot specify lines in which no assembler instructions have been generated, including comment lines and blank lines.
- If you omit the name of the source file, the line Nos. apply to the source file displayed in the Program Window.
- Include the file attribute in the name of the source file.
- Do not include any spaces between the line No. and name of the source file.

2.2.8 Character constants

The specified character or character string is converted into ASCII code and processed as a constant.

- Enclose characters in single quote marks.
- Enclose character strings in double quote marks.
- The character string must consist of one or two characters (16 bits max.).
If more than two characters are specified, the last two characters of the string are processed. For example, "ABCD" would be processed as "CD", or value 4344₁₆.

2.2.9 Operators

The table below lists the operators that you can use in expressions.

- The priority of operators is indicated by the level, level 1 being the highest and level 8 the lowest.
If two or more operators have the same level of priority, they are evaluated in order from the left of the expression.

Operator	Function	Priority level
()	Brackets	Level 1
+, =, ~	Monadic positive, monadic negative, monadic logical NOT	Level 2
*, /	Dyadic multiply, dyadic divide	Level 3
+, -	Dyadic add, dyadic subtract	Level 4
>>, <<	Right shift, left shift	Level 5
&	Dyadic logical AND	Level 6
, ^	Dyadic logical OR, dyadic exclusive OR	Level 7
<, <=, >, >=, ==, !=	Dyadic comparison	Level 8

3 C Expressions

3.1 Writing C Expressions

You can use C expressions consisting of the tokens shown below for registering C watchpoints and for specifying the values to be assigned to C watchpoints.

Token	Example
Immediate values	10, 0x0a, 012
Mathematical operators	+, -, *, /
Pointers	*, **, ...
Reference	&
Sign inversion	-
Member reference using comma	Struct.Member
Member reference using arrow	Struct->Member
Parentheses	(,)
Arrays	Array [2] , DArray [2] [3] , ...
Casting to basic types	(int), (char*), (unsigned long *), ...
Casting to typedef types	(DWORD), (ENUM), ...
Variable names and function names	var, i, j, func, ...
Character constants	'A', 'b', ...
Character string literals	"abcdef", "I am a boy.", ...

3.1.1 Immediate Values

You can use hexadecimals, decimals, and octals as immediate values. Values starting with 0x are processed as hexadecimals, those with 0 as octals, and those without either prefix as decimals.

Notes:

- You cannot register only immediate values as C watchpoints.
- Immediate values are valid only when used in a C expression that specifies a C watchpoint, and when specifying a value to be assigned.

3.1.2 Mathematical Operators

You can use the addition (+), subtraction (-), multiplication (*), and division (/) mathematical operators. The following shows the order of priority in which they are evaluated.

$(*), (/) > (+), (-)$

Note:

- There is no support currently for mathematical operators for floating point numbers.

3.1.3 Pointers

Pointers are indicated by the asterisk (*). You can use pointer to pointers **, and pointer to pointer to pointers ***, etc.

Examples: "*variable_name", "**variable_name", etc.

Note:

- Immediate values cannot be processed as pointers. That is, you cannot specify *0xE000, for example.

3.1.4 Reference

References are indicated by the ampersand (&). You can only specify "&variable_name".

3.1.5 Sign Inversion

Sign inversion is indicated by the minus sign (-). You can only specify "-immediate_value" or "-variable_name". No sign inversion is performed if you specify 2 (or any even number of) minus signs.

Note:

- There is no support currently for sign inversion of floating point numbers.

3.1.6 Member Reference Using Comma

You can only use "variable_name.member_name" for checking the members of structures and unions using the comma.

Example:

```
struct s{
    int    member1;
    char   member2;
};

struct S    STRUCT;
struct S    *STRUCT_P;
```

In this case, `STRUCT.member1`, `(*STRUCT_P).member2` correctly checks the members.

3.1.7 Member Reference Using Arrow

You can only use "variable_name->member_name" for checking the members of structures and unions using the arrow.

Example:

```
struct s{
    int    member1;
    char   member2;
};

struct S      STRUCT;
struct S      *STRUCT_P;
```

In this case, (&STRUCT)->member1, STRUCT_P->member2 correctly checks the members.

3.1.8 Parentheses

Use the '(' and ')' to specify priority of calculation within an expression.

3.1.9 Arrays

You can use the '[' and ']' to specify the elements of an array. You can code arrays as follows: "variable_name [(element_No or variable)] ", "variable_name [(element_No or variable)] [(element_No or variable)] ", etc.

3.1.10 Casting to Basic Types

You can cast to C basic types char, short, int, and long, and cast to the pointer types to these basic types. When casting to a pointer type, you can also use pointers to pointers and pointers to pointers to pointers, etc.

Note that if signed or unsigned is not specified, the default values are as follows:

Basic type	Default
char	unsigned
short	signed
int	signed
long	signed

Notes:

- You cannot cast to floating point C basic types (float and double).
- You cannot cast register variables.

3.1.11 Casting to typedef Types

You can use casting to typedef types (types other than the C basic types) and the pointer types to them. When casting to a pointer type, you can also use pointers to pointers and pointers to pointers to pointers, etc.

Note:

- You cannot cast to struct or union types or the pointers to those types.

3.1.12 Variable Names and Function Names

As defined in C, variable and function names are character strings that start with a letter. They can consist of up to 255 characters.

3.1.13 Character Constants

You can use characters enclosed in single quote marks (') as character constants. For example, 'A', 'b', etc. These character constants are converted to ASCII code and used as 1-byte immediate values.

Notes:

- You cannot register character constants only as C watchpoints.
- Character constants are valid only when used in a C expression that specifies a C watchpoint, and when specifying a value to be assigned (character constants are processed in the same manner as immediate values).

3.1.14 Character String Literals

You can use character strings enclosed in double quote marks (") as character string literals. Examples are "abcde", "I am a boy.", etc.

Note:

- Character string literals can only be placed on the right side of an assignment operator in an expression. They can only be used when the left side of the assignment operator is a char array or a char pointer type. In all other cases, a syntax error results.

3.2 Display Format of C Expressions

C expressions in the data display areas of the C Watch, File, File Local, and Global Windows are displayed as their type name, C expression (variable name), and result of calculation (value), as shown below.

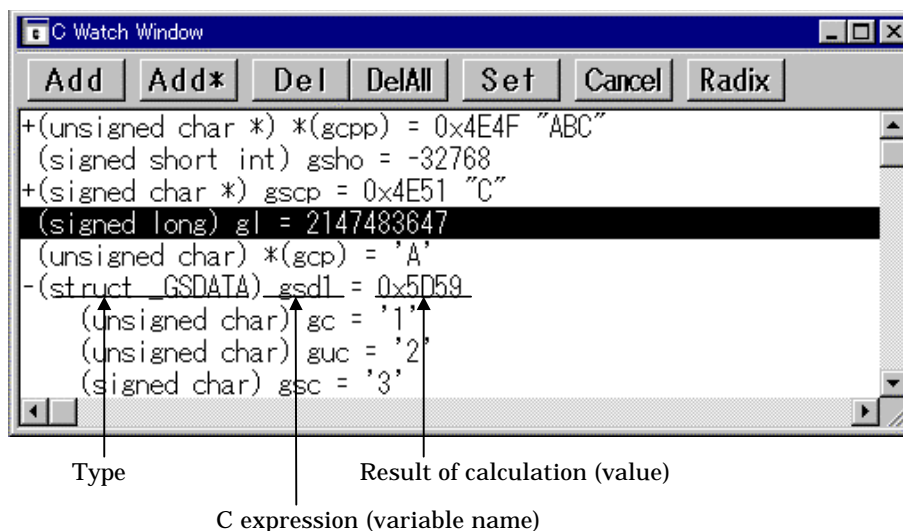

The following describes the display formats of the respective types.

3.2.1 Enumeration Types

- When the result (value) of calculation has been defined, its name is displayed.
 (DATE) date = **Sunday** (all Radices)
- If the result (value) of calculation has not been defined, it is displayed as follows:
 (DATE) date = **16** (when Radix is in initial state)
 (DATE) date = **0x10** (when Radix is hex)
 (DATE) date = **0000000000010000B** (when Radix is binary)

3.2.2 Basic Types

- When the result of calculation is a basic type other than a char type or floating point type, it is displayed as follows:
 (unsigned int) i = **65280** (when Radix is in initial state)
 (unsigned int) i = **0xFF00** (when Radix is hex)
 (unsigned int) i = **1111111100000000B** (when Radix is binary)
- When the result of calculation is a char type, it is displayed as follows:
 (unsigned char) c = **'J'** (when Radix is in initial state)
 (unsigned char) c = **0x4A** (when Radix is hex)
 (unsigned char) c = **10100100B** (when Radix is binary)
- When the result of calculation is a floating point, it is displayed as follows:
 (double) d = **8.207880399131839E-304** (when Radix is in initial state)
 (double) d = **0x10203045060708** (when Radix is hex)
 (double) d = **000000010.....1000B** (when Radix is binary)
 (..... indicates abbreviation)

3.2.3 Pointer Types

- When the result of calculation is a pointer type to other than a char* type, it is displayed in hexadecimal as follows:
 (unsigned int *) p = **0x1234** (all Radices)
- When the result of calculation is a char* type, you can select the display format of the string or a character in the menu [Option] -> [View] -> [Display String].
 -string types
 (unsigned char *) str = **0x1234 "Japan"** (all Radices)
 -character types
 (unsigned char *) str = **0x1234 (74 'J')** (all Radices)

- When the result of calculation is a char* type, it is displayed as follows:

```
(unsigned char *) str = 0x1234 "Japan" (all Radices)
```

If the string contains a non-printing code prior to the code to show the end of the string (0), it is displayed up to the non-printing character and the closing quote mark is not displayed.

```
(unsigned char *) str = 0x1234 "Jap" (all Radices)
```

Also if the string contains more than 80 characters, the closing quote mark is not displayed.

When the C expression is an pointer type, a '+' is displayed to the left of the type name.

'+' indicating pointer type

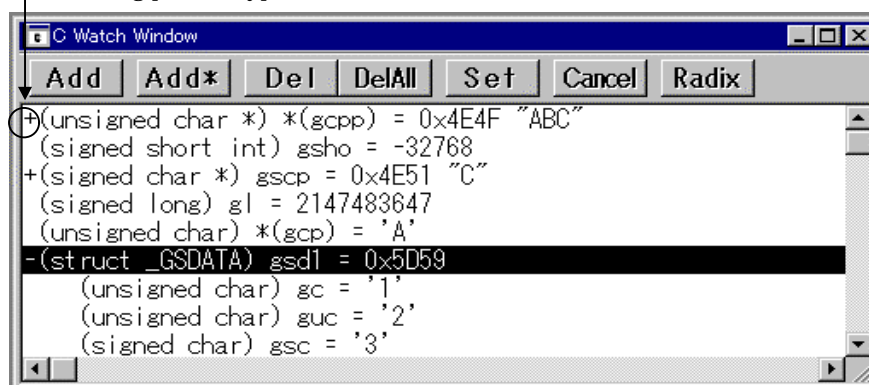

You can double-click on lines indicated by a '+' to see the members of that structure or union. The '+' changes to a '-' while the members are displayed. To return to the original display, double click the line, now indicated by the '-'.

3.2.4 Array Types

- When the result of calculation is an array type other than a char [] type, the starting address is displayed in hex as follows:

```
(signed int [ 10 ] ) z = 0x1234 (all Radices)
```
- When the result of calculation is a char [] type, it is displayed as follows:

```
(unsigned char [ 10 ] ) str = 0x1234 "Japan" (all Radices)
```

If the string contains a non-printing code prior to the code to show the end of the string (0), it is displayed up to the non-printing character and the closing quote mark is not displayed.

```
(unsigned char [ 10 ] ) str = 0x1234 "Jap" (all Radices)
```

Also if the string contains more than 80 characters, the closing quote mark is not displayed.

When the C expression is an array type as same as pointer type, a '+' is display to the left of the type name. You can see the elements of the array by using this indicating. (for the details, refer 3.2.4 Pointer types)

When the number of the array elements is more than 1000, the following dialog box open. Specify the number of the elements in the dialog box.

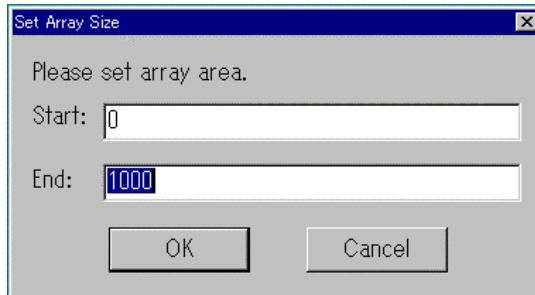

The elements from the index specified in "Start" to the index specified in "End" are displayed. If you specify the value more than the max index of the array, the value is regarded as max index of the array.

When you click the "Cancel" button, the elements are not displayed.

3.2.5 Function Types

- When the result of calculation is a function type, the starting address is displayed in hex as follows:
`(void()) main = 0xF000` (all Radices)

3.2.6 Reference Types

- When the result of calculation is a reference type, the reference address is displayed in hex as follows:
`(signed int &) ref = 0xD038` (all Radices)

3.2.7 Bit Field Types

- When the result of calculation is a bit field type, it is displayed as follows:
`(unsigned int :13) s.f = 8191` (when Radix is in initial state)
`(unsigned int :13) s.f = 0x1FFF` (when Radix is hex)
`(unsigned int :13) s.f = 1111111111111B` (when Radix is binary)

3.2.8 When No C Symbol is Found

- If the calculated expression contained a C symbol that could not be found, it is displayed as follows:
`() x = <not active>` (all Radices)

3.2.9 Syntax Errors

- When the calculated expression contains a syntax error, it is displayed as follows:
`() str*(p = <syntax error>` (all Radices)
 (where `str*(p` is the syntax error)

3.2.10 Structure and Union Types

- When the result of calculation is a structure or union type, the address is displayed in hex as follows:

(Data) v = 0x1234 (all Radices)

If, as in structures and unions, the C expression consists of members, a '+' is displayed to the left of the type name (tag name).

'+' indicating structure or union

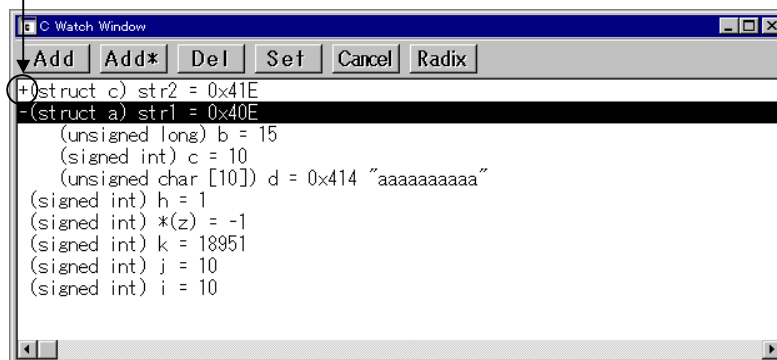

You can double-click on lines indicated by a '+' to see the members of that structure or union. The '+' changes to a '-' while the members are displayed. To return to the original display, double click the line, now indicated by the '-'. This function allows you to check the members of structures and unions.

3.2.11 Register Variables

- When the result of calculation is a register variable, "register" is displayed to the left of the type name as follows:

(register signed int) j = 100

4 Error Messages

The following tables list the PD38SIM error messages.

No.	Error Message	Notes and Action
150	Can't open more (name) window.	The maximum number of the specified window is already open.
151	Can't Create (name) window.	Cannot open the specified window. There may not be sufficient memory. Quit other applications or increase memory.
152	Can't open (name) window, when the target program is running.	Stop the target program, then open the window.
153	Value is out of range.	The specified address exceeds the MCU's maximum address .
154	PD38SIM is already exist.	
156	File not found (filename).	
157	Path not found (path).	
158	Not enough memory.	
159	Can't execute.	

No.	Error Message	Notes and Action
200	Can't change view mode.	The display starting address does not match the first line of the source file, or the specified source file cannot be found.
201	Can't find source file (filename).	Specified source file was not found. Use the PATH command, or the [Environ] [Path] menu items to specify the directory containing the source file.
202	Can't find search string (name).	The specified search string was not found between the starting position and end.
203	Line number of Source File (filename) is over (line).	Because the source file has more lines than can be displayed, the file cannot be displayed in the Source Window. Switch to disassemble display mode.

No.	Error Message	Notes and Action
300	Illegal endi. (filename line)	There is no if statement paired with the endi statement.
301	Illegal endw. (filename line)	There is no while statement paired with the endw statement.
303	Script File is already exist.	
304	Can't find endi. (filename line)	There is no endi statement paired with the if statement.
305	Line length is overflow. (filename line)	The number of characters exceeds the maximum permissible for one line.
306	Nest level is overflow. (filename line)	
307	Can't find Script File (filename).	
308	Can't read Script File (filename).	Cannot read rest of script file.
309	Description is illegal. (filename line)	
310	Can't find endw. (filename line)	There is no endw statement paired with while statement.
311	The nest level exceeds the limit (limit).	
313	Illegal break. (filename line)	

No.	Error Message	Notes and Action
400	Address value is out range for scroll area.	

No.	Error Message	Notes and Action
600	Can't add new watch point because it exceeds limit of watch point number. Max number is (num).	
601	Address value is out of range.	
602	Data value is out of range.	
603	Bit value is out of range.	

No.	Error Message	Notes and Action
650	There are no symbol information.	Load module file not loaded.
651	The expression is too long.	

No.	Error Message	Notes and Action
900	SYMBOL file is illegal.	Error in format of load module file.
901	Loading is canceled.	
902	Can't find SYMBOL file (filename).	No load module file exists.
903	Can't get enough memory.	Insufficient memory. Quit other applications or increase memory.
904	Cannot open temporary file.	The temporary file for downloading using the on-demand method could be opened.

No.	Error Message	Notes and Action
1001	Can't find symbol.	Specified symbol does not exist.
1002	Description of expression is illegal.	
1004	Description is illegal.	Error in expression.
1005	Can't find scope.	The specified variable is not within the scope.
1006	Can't find symbol.	
1007	Can't find function.	The specified function does not exist.
1008	Right hand side of the expression is illegal.	
1009	The Type of structure (union) are not same.	
1010	Can't assign.	
1011	Can't find type.	The specified type does not exist.
1012	Not supported float (double) operation.	
1013	The operation does not be allowed to pointers.	
1014	The operation does not be allowed to the pointer.	
1015	Can't decrease by pointer.	
1016	Divided by 0.	
1017	The operator is not supported.	
1018	Type information is broken.	Error in symbol information in load module file.
1019	Left value must be the pointer.	
1020	Left value must be a structure or an union.	
1021	Can't find member.	
1022	Left value must be reference of a structure or an union.	
1023	Left value is illegal.	
1024	The operand must be a value.	
1025	The operand is able to be opposite sign.	

No.	Error Message	Notes and Action
1026	Can't get address value.	
1027	The array variable is illegal.	
1028	The essential number of array is illegal.	
1029	The operand must be an address value.	
1030	Type casting for register variable is not be supported.	
1031	The type of type casting is illegal.	
1032	Type casting for that type is not be supported.	
1033	This expression can not be exchanged for some address value.	

No.	Error Message	Notes and Action
1100	Address value is out of range.	Specified address exceeds MCU's maximum address.
1101	Description of Assembly language is illegal.	
1102	Address value for JUMP is out of range.	
1103	Operand value is out of range.	
1104	Description of expression is illegal.	

No.	Error Message	Notes and Action
1200	Syntax error.	
1201	Command name is wrong.	
1202	Too many aliases.	Maximum: 256
1203	You can register the only command name for alias.	
1204	Can't use the command now.	You cannot use the specified command while the target program is running.
1205	Can't up more.	
1206	Can't down more.	
1207	Can't set break point in this function.	
1208	The start address larger than the end address.	
1209	Can't register that token for alias.	
1211	This command is not supported now.	
1212	Can't find File (filename).	
1213	Data value is out of range.	

No.	Error Message	Notes and Action
1300	Line number is illegal.	
1301	Can't find right bracket ') '.	
1302	The Number of Macro constant is over the limit (limit).	
1303	Immediate value is out of range.	
1304	Prefix which gives radix of the constant is illegal.	
1305	Description of indirect reference is illegal.	
1306	Can't find end of strings (str).	
1307	Description of expression is illegal.	
1308	Macro constant (macro) isn't defined.	
1309	Symbol (symbol) isn't defined.	
1310	Immediate value is illegal.	
1311	Divide by 0.	
1313	The value is over the maximum value of which can be treated by MCU.	
1314	Register name is using for macro variable name.	

No.	Error Message	Notes and Action
1400	Address value is out of range.	
1401	Target program is already stopped.	
1402	The number of break point is over the limit .	
1403	The break point isn't defined at that address.	
1404	Data value is out of range.	
1406	Can't read/write, because there are no memory at that area.	
1407	Can't get enough memory.	
1408	Register value is out of range.	
1409	Can't execute that command, when the target program is running.	
1410	Start address is larger than end address.	
1411	STOP execution.	
1412	Can't find source lines which include that address.	
1413	That command has not yet supported.	
1417	Can't search more on the stack.	
1418	Specified times of number is over than 65535.	
1450	Address value is out of range.	

No.	Error Message	Notes and Action
1500	There was sent undefined data from simulator.	
1501	Can't read/write, because there are no memory at that area.	
1502	Number of points exceeds the limit (limit).	
1503	Point already set.	
1504	Breakpoint of other type already set.	
1505	No hardware breakpoint set at specified address.	
1506	Can't get enough memory.	
1507	Can't set more I/O script file. (Max 20)	
1508	Can't set more virtual output. (Max 20)	
1509	Specified vector No. out of range.	
1510	Specified level of priority out of range.	
1550	Address value is out of range.	
1551	Bit number is out of range.	
1552	File (filename) is broken.	
1553	Can't find File (filename).	
1554	Can't find sub routine information.	
1555	Illegal character in the strings.	
1557	Can't find that line number.	
1558	Multiple definition of symbol/label.	
1559	There are no code at that line.	
1560	Can't get enough memory.	
1561	Can't find scopes.	
1562	Can't find section information.	
1563	Can't find source lines which correspond to that address.	
1564	Can't find symbol (symbol).	
1565	Can't find the scopes which include that address.	
1566	Loading is canceled.	
1569	The register name is wrong.	

No.	Error Message	Notes and Action
1704	The connection with the target isn't created.	
1705	Can't connect with the target.	
1707	Time Out ERROR.	A time-out error occurred in communication with the target system.
1712	Communication ERROR.	Connection to the target system was lost during communication with the target system.
1713	Communication ERROR.	A communications error occurred while sending data to the target system.
1714	Communication ERROR.	A communications error occurred while sending data to the target system.
1717	Can't find Simulator Engine.	

No.	Error Message	Notes and Action
2400	Address value is out of range.	
2401	Data value is out of range.	
2402	Start Address value is out of range.	You specified an ending address that is less than the starting address.
2403	Value is under (num).	Specify a value of num or more.
2404	Data value is out of range.	

No.	Error Message	Notes and Action
5700	The data value is too large.	
5701	The address area is illegal.	
5702	Address value is out range for scroll area.	The address specified as the scroll range is greater than the MCU's maximum address.

No.	Error Message	Notes and Action
5800	Sampling period value is out of range.	
5801	Address value is out of range.	
5802	Can't change RAM monitor area, when the target program is running.	Stop target program, then change the RAM monitor area.

No.	Error Message	Notes and Action
5900	Can't open Script File (filename).	
5901	Script File (filename) is already opened.	
5902	Script File is not open.	
5903	Can't open Log File (filename).	
5904	Can't open more Log File.	
5905	Can't open Log File.	
5906	File (filename) is already log on.	
5907	Can't open View File (filename) for new/add.	

No.	Error Message	Notes and Action
6000	Cannot find source file (filename).	
6001	The number of lines of source file (filename) is over the limit (limit).	
6002	The address value is out of range.	
6003	Cannot open file (filename).	
6004	Illegal file format.	
6006	Cannot read the file saved by emulator debugger.	

No.	Error Message	Notes and Action
6401	Already set hard ware break.	

No.	Error Message	Notes and Action
10800	Value is out of range.	
10801	Can't find the register information file.	
10802	There's incorrect line in register information file.	
10803	Not enough memeory.	

No.	Error Message	Notes and Action
11000	Address value is out of range.	
11001	The save file name (filename) is wrong.	
11003	File Name is illegal.	

No.	Error Message	Notes and Action
20000	Illegal file format.	

No.	Error Message	Notes and Action
21000	Can't open BUTTON file.	
21001	BUTTON file is illegal.	

No.	Error Message	Notes and Action
22000	Can't open temporary file.	
22001	Can't delete temporary file.	
22002	Can't open data file (filename).	
22003	The data not set.	
22004	The Output file of the same already set.	
22005	Data not found.	
22006	The start cycle larger than the end cycle.	
22007	The Output port already set.	
22008	There is no data in the Input file.	
22009	Illegal file format.	

No.	Error Message	Notes and Action
25000	Can't find '{'. (line)	
25001	Can't find '}'. (line)	
25002	Can't find '('. (line)	
25003	Symbol isn't defined. (line , symbol)	
25004	Can't find ')'.(line)	
25005	Description of expression is illegal. (line , token)	
25006	Nest level of the if statement is overflow. (line)	
25007	Nest level of the while statement is overflow. (line)	
25008	Too many the break statement. (line)	
25009	There is no if statement corresponding to the else statement. (line)	
25010	Unknown token. (line , token)	
25011	Can't open the (filename) file.	
25012	The (filename) file is not a file made in the I/O window.	
25013	The description of the memory variable is illegal. (line)	

No.	Error Message	Notes and Action
30000	Can't open file (filename).	
30001	Can't create file (filename).	
30002	Can't close file (filename).	
30003	File seek error (in filename).	
30004	Out of disk space.	
30005	Illegal file format (filename)	
30006	Out of heap space.	
30007	Not yet implemented (data).	

[MEMO]

Index

-
- #
- #isfetch expression.....202
 - #isint expression203
 - #isread expression203
 - #iswrite expression203
- A
- ASM Watch Window.....5, 50, 111
 - Assign Statement.....223
 - AutoDownLoad.....95
- B
- Break Functions.....5
 - Break Statement.....224
- C
- “Come”button107
 - C expression53, 230, 233
 - C language expression.....129
 - C variable127, 129
 - C Watch Window.....5, 53, 128
 - C watchpoint53
 - C watchpoint data file13
 - CB38SIM207
 - Character constant202, 229
 - Come Execution107
 - Comment200
 - Comment statement224
 - Composition of I/O Script196
 - Conditional Statement224
 - Constant200, 226
 - Coverage measurement information
.....205
 - coverage measurement information
file13, 14
 - Coverage Source Window.....84
 - Coverage Window84
 - Customize Dialog Box.....144
 - Customize Function.....207
- CYcle command 11
- Cycle synchronized input.....63, 147
- Cycle synchronized interrupt66, 158
- D
- Disassemble.....102
 - Disassemble file14
 - Downloading193
 - Dump Window.....93
- E
- Editor144
 - Else224
 - endi224
 - endw.....224
 - environmental setup file13
 - Error Messages238
 - Executed address synchronized
interrupt.....67, 161
 - Exit137
- F
- File Local Window5, 58, 128
 - Font size21
- G
- “Go”button104
 - Global label symbol.....226
 - Global Window5, 60, 128
 - GUI Input.....10
 - GUI Input File15
 - GUI Input Window80, 179
 - GUI Output11
 - GUI Output File.....15
 - GUI Output Window82, 185
- H
- H/W Break Point Setting dialog box
.....89, 122
 - Hardware Break5, 122
 - Hardware break point89
-

help file	12	PD38SIM setup.....	20
I		PD38SIM version.....	143
I/O Script	11, 195	PD38SIM Window	27
I/O Script File.....	14	Program counter	33, 38
I/O Window.....	63	Program Window.....	21, 33, 93, 97, 98, 141
IEEE-695 Absolute Format File.....	12, 93	Procedure	197
if	199	R	
Init dialog	20	“Reset”button	107
Init Dialog Box.....	20, 136	“Return”button.....	106
Installation	19	RAM monitor area	4, 47, 111
int statement.....	198	RAM Monitor Function	4
Intel HEX format File	12, 14, 97	RAM Monitor Window	47, 111
Interrupt synchronized input.....	65, 152	Read access synchronized input.....	64, 150
L		Real-time RAM monitor function.....	111
Label	5, 226	Register information file	12
Left-side expressions	203	Register variable.....	228
Line Assemble	139	Register Window.....	41, 108
line No.....	228	Reload	95
Local label symbol.....	226	Reset	96, 107
Local Window	5, 56, 128	Return execution	106
log file	14, 61	Right-side expressions.....	200
Logging function	132	S	
Loop Statement.....	224	“Step”button	105
M		“Stop”button	104
Macro variable	201, 204, 227	S/W Break Point Setting dialog box	87, 117
Main command.....	27	Sampling period.....	111
Memory Window	43, 114	Save Disasm	97
memory variables.....	201, 204	Scope	226
Multi-Windowing Function.....	4	Scope Setting dialog box	114
O		Script Command	223
“Over”button.....	015	Script file	12, 21, 61, 136
Operator.....	202, 229	Script Window.....	61, 131
Over-step execution	105	Search.....	141
P			
pass statement	199		

-
- Search path 100
set statement..... 198
Setup..... 19
sim38 setup..... 23
Software Break 5, 87, 117
Software breakpoint file..... 13, 14
Source Level Debugging Function . 5
Source Window 21, 38, 93, 97, 98, 141
Stack Utilization Monitor 11
StackMonitor command 11
Starting PD38SIM..... 19
Step Execution 105
Symbol 5, 226
Symbol File..... 12
Symbols and Labels 201
- T
- Table of Script Commands 213
TAB value..... 21
temporary file..... 15
The Virtual Port Input function . 147
Time management 7
- U
- Uploading 97
- V
- Version Information dialog box 23
View buffer 14, 61, 133
View file..... 14, 61, 133
Virtual Interrupt 10, 66
Virtual Interrupt function 158
Virtual Port Input..... 9, 63
Virtual Port Output..... 9, 66, 156
Virtual Port Output File 15
Virtual Port Output function..... 156
- W
- wait statement 197
waitc statement..... 197
- Watchpoint 50
while 199, 224
Writing Script Files..... 223

[MEMO]

M3T-PD38SIM V.2.10 User's Manual

Rev. 1.00
May 1, 2003
REJ10J0047-0100Z

COPYRIGHT ©2003 RENESAS TECHNOLOGY CORPORATION
AND RENESAS SOLUTIONS CORPORATION ALL RIGHTS RESERVED

M3T-PD38SIM V.2.10
User's Manual



Renesas Electronics Corporation

1753, Shimonumabe, Nakahara-ku, Kawasaki-shi, Kanagawa 211-8668 Japan

REJ10J0047-0100Z