

To our customers,

---

## Old Company Name in Catalogs and Other Documents

---

On April 1<sup>st</sup>, 2010, NEC Electronics Corporation merged with Renesas Technology Corporation, and Renesas Electronics Corporation took over all the business of both companies. Therefore, although the old company name remains in this document, it is a valid Renesas Electronics document. We appreciate your understanding.

Renesas Electronics website: <http://www.renesas.com>

April 1<sup>st</sup>, 2010  
Renesas Electronics Corporation

Issued by: Renesas Electronics Corporation (<http://www.renesas.com>)

Send any inquiries to <http://www.renesas.com/inquiry>.

## Notice

1. All information included in this document is current as of the date this document is issued. Such information, however, is subject to change without any prior notice. Before purchasing or using any Renesas Electronics products listed herein, please confirm the latest product information with a Renesas Electronics sales office. Also, please pay regular and careful attention to additional and different information to be disclosed by Renesas Electronics such as that disclosed through our website.
2. Renesas Electronics does not assume any liability for infringement of patents, copyrights, or other intellectual property rights of third parties by or arising from the use of Renesas Electronics products or technical information described in this document. No license, express, implied or otherwise, is granted hereby under any patents, copyrights or other intellectual property rights of Renesas Electronics or others.
3. You should not alter, modify, copy, or otherwise misappropriate any Renesas Electronics product, whether in whole or in part.
4. Descriptions of circuits, software and other related information in this document are provided only to illustrate the operation of semiconductor products and application examples. You are fully responsible for the incorporation of these circuits, software, and information in the design of your equipment. Renesas Electronics assumes no responsibility for any losses incurred by you or third parties arising from the use of these circuits, software, or information.
5. When exporting the products or technology described in this document, you should comply with the applicable export control laws and regulations and follow the procedures required by such laws and regulations. You should not use Renesas Electronics products or the technology described in this document for any purpose relating to military applications or use by the military, including but not limited to the development of weapons of mass destruction. Renesas Electronics products and technology may not be used for or incorporated into any products or systems whose manufacture, use, or sale is prohibited under any applicable domestic or foreign laws or regulations.
6. Renesas Electronics has used reasonable care in preparing the information included in this document, but Renesas Electronics does not warrant that such information is error free. Renesas Electronics assumes no liability whatsoever for any damages incurred by you resulting from errors in or omissions from the information included herein.
7. Renesas Electronics products are classified according to the following three quality grades: “Standard”, “High Quality”, and “Specific”. The recommended applications for each Renesas Electronics product depends on the product’s quality grade, as indicated below. You must check the quality grade of each Renesas Electronics product before using it in a particular application. You may not use any Renesas Electronics product for any application categorized as “Specific” without the prior written consent of Renesas Electronics. Further, you may not use any Renesas Electronics product for any application for which it is not intended without the prior written consent of Renesas Electronics. Renesas Electronics shall not be in any way liable for any damages or losses incurred by you or third parties arising from the use of any Renesas Electronics product for an application categorized as “Specific” or for which the product is not intended where you have failed to obtain the prior written consent of Renesas Electronics. The quality grade of each Renesas Electronics product is “Standard” unless otherwise expressly specified in a Renesas Electronics data sheets or data books, etc.
  - “Standard”: Computers; office equipment; communications equipment; test and measurement equipment; audio and visual equipment; home electronic appliances; machine tools; personal electronic equipment; and industrial robots.
  - “High Quality”: Transportation equipment (automobiles, trains, ships, etc.); traffic control systems; anti-disaster systems; anti-crime systems; safety equipment; and medical equipment not specifically designed for life support.
  - “Specific”: Aircraft; aerospace equipment; submersible repeaters; nuclear reactor control systems; medical equipment or systems for life support (e.g. artificial life support devices or systems), surgical implantations, or healthcare intervention (e.g. excision, etc.), and any other applications or purposes that pose a direct threat to human life.
8. You should use the Renesas Electronics products described in this document within the range specified by Renesas Electronics, especially with respect to the maximum rating, operating supply voltage range, movement power voltage range, heat radiation characteristics, installation and other product characteristics. Renesas Electronics shall have no liability for malfunctions or damages arising out of the use of Renesas Electronics products beyond such specified ranges.
9. Although Renesas Electronics endeavors to improve the quality and reliability of its products, semiconductor products have specific characteristics such as the occurrence of failure at a certain rate and malfunctions under certain use conditions. Further, Renesas Electronics products are not subject to radiation resistance design. Please be sure to implement safety measures to guard them against the possibility of physical injury, and injury or damage caused by fire in the event of the failure of a Renesas Electronics product, such as safety design for hardware and software including but not limited to redundancy, fire control and malfunction prevention, appropriate treatment for aging degradation or any other appropriate measures. Because the evaluation of microcomputer software alone is very difficult, please evaluate the safety of the final products or system manufactured by you.
10. Please contact a Renesas Electronics sales office for details as to environmental matters such as the environmental compatibility of each Renesas Electronics product. Please use Renesas Electronics products in compliance with all applicable laws and regulations that regulate the inclusion or use of controlled substances, including without limitation, the EU RoHS Directive. Renesas Electronics assumes no liability for damages or losses occurring as a result of your noncompliance with applicable laws and regulations.
11. This document may not be reproduced or duplicated, in any form, in whole or in part, without prior written consent of Renesas Electronics.
12. Please contact a Renesas Electronics sales office if you have any questions regarding the information contained in this document or Renesas Electronics products, or if you have any other inquiries.

(Note 1) “Renesas Electronics” as used in this document means Renesas Electronics Corporation and also includes its majority-owned subsidiaries.

(Note 2) “Renesas Electronics product(s)” means any product developed or manufactured by or for Renesas Electronics.

# M30262T-PTC

Converter Board for M30262

## User's Manual

### Keep safety first in your circuit designs!

- Renesas Technology Corporation and Renesas Solutions Corporation put the maximum effort into making semiconductor products better and more reliable, but there is always the possibility that trouble may occur with them. Trouble with semiconductors may lead to personal injury, fire or property damage. Remember to give due consideration to safety when making your circuit designs, with appropriate measures such as (i) placement of substitutive, auxiliary circuits, (ii) use of nonflammable material or (iii) prevention against any malfunction or mishap.

### Notes regarding these materials

- These materials are intended as a reference to assist our customers in the selection of the Renesas Technology product best suited to the customer's application; they do not convey any license under any intellectual property rights, or any other rights, belonging to Renesas Technology Corporation, Renesas Solutions Corporation or a third party.
- Renesas Technology Corporation and Renesas Solutions Corporation assume no responsibility for any damage, or infringement of any third-party's rights, originating in the use of any product data, diagrams, charts, programs, algorithms, or circuit application examples contained in these materials.
- All information contained in these materials, including product data, diagrams, charts, programs and algorithms represents information on products at the time of publication of these materials, and are subject to change by Renesas Technology Corporation and Renesas Solutions Corporation without notice due to product improvements or other reasons. It is therefore recommended that customers contact Renesas Technology Corporation, Renesas Solutions Corporation or an authorized Renesas Technology product distributor for the latest product information before purchasing a product listed herein. The information described here may contain technical inaccuracies or typographical errors. Renesas Technology Corporation and Renesas Solutions Corporation assume no responsibility for any damage, liability, or other loss rising from these inaccuracies or errors. Please also pay attention to information published by Renesas Technology Corporation and Renesas Solutions Corporation by various means, including the Renesas home page (<http://www.renesas.com>).
- When using any or all of the information contained in these materials, including product data, diagrams, charts, programs, and algorithms, please be sure to evaluate all information as a total system before making a final decision on the applicability of the information and products. Renesas Technology Corporation and Renesas Solutions Corporation assume no responsibility for any damage, liability or other loss resulting from the information contained herein.
- Renesas Technology semiconductors are not designed or manufactured for use in a device or system that is used under circumstances in which human life is potentially at stake. Please contact Renesas Technology Corporation, Renesas Solutions Corporation or an authorized Renesas Technology product distributor when considering the use of a product contained herein for any specific purposes, such as apparatus or systems for transportation, vehicular, medical, aerospace, nuclear, or undersea repeater use.
- The prior written approval of Renesas Technology Corporation and Renesas Solutions Corporation is necessary to reprint or reproduce in whole or in part these materials.
- If these products or technologies are subject to the Japanese export control restrictions, they must be exported under a license from the Japanese government and cannot be imported into a country other than the approved destination. Any diversion or reexport contrary to the export control laws and regulations of Japan and/or the country of destination is prohibited.
- Please contact Renesas Technology Corporation or Renesas Solutions Corporation for further details on these materials or the products contained therein.

### Precautions to be taken when using this product

- This product is a development supporting unit for use in your program development and evaluation stages. In mass-producing your program you have finished developing, be sure to make a judgment on your own risk that it can be put to practical use by performing integration test, evaluation, or some experiment else.
- In no event shall Renesas Solutions Corporation be liable for any consequence arising from the use of this product.
- Renesas Solutions Corporation strives to renovate or provide a workaround for product malfunction at some charge or without charge. However, this does not necessarily mean that Renesas Solutions Corporation guarantees the renovation or the provision under any circumstances.
- This product has been developed by assuming its use for program development and evaluation in laboratories. Therefore, it does not fall under the application of Electrical Appliance and Material Safety Law and protection against electromagnetic interference when used in Japan.



### CAUTION

If the requirements shown in the "CAUTION" sentences are ignored, the equipment may cause personal injury or damage to the products.

Renesas Tools Homepage <http://www.renesas.com/en/tools>

# 1. Outline

The M30262T-PTC is a converter board for the M30262Group for connecting an emulator for the M16C/62P to M30262 (48P6Q-A)

# 2. Package Components (See Figure 1)

- (1) M30262T-PTC 1 pc.  
(Base board M30262T-PTCB and 150mm FFC cable included)
- (2) YQPACK048SD (by Tokyo Eletech Corporation) 1 pc.
- (3) NQPACK048SD (by Tokyo Eletech Corporation) 1 pc.
- (4) YQ-GUIDE's (4 pcs., by Tokyo Eletech Corporation) 1 pkg.
- (5) M30262T-PTC User's Manual (This manual) 1 pc.

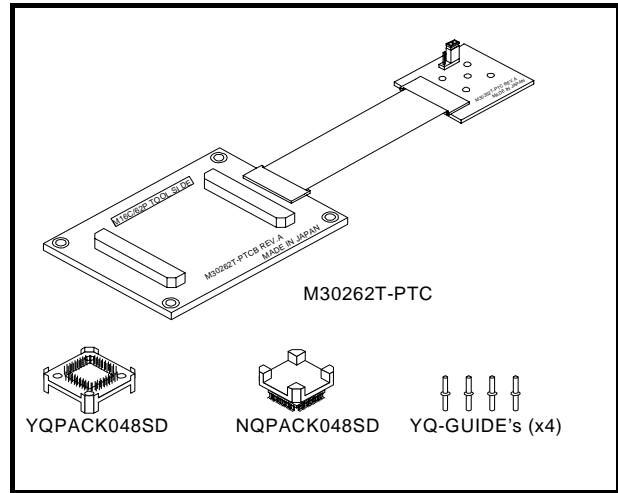

Figure 1 Package components of the M30262T-PTC

# 3. Specifications

Table 1 Specifications

Applicable package	48P6Q-A (48-pin 0.5-mm-pitch QFP)
Insertion/removal iterations of connector	M30262T-PTC and YQPACK048SD 100 times guaranteed
	M30262T-PTC and emulator for M16C/62P 20 times guaranteed

# 4. Usage (See Figure 2)

The M30262T-PTC can be used for debugging and onboard evaluation in common by mounting the NQPACK048SD on the target board.

- (1) For debugging  
Mount the NQPACK048SD and the YQPACK048SD in that order on the foot pattern of the target board. Then attach the YQ-GUIDE's to the YQPACK048SD to connect the M30262T-PTC. Do not use the screws included with the YQPACK048SD. Finally, connect the emulator for M16C/62P to the M30262T-PTC.
- (2) For onboard evaluation  
Mount the M30262 MCU and the HQPACK048SD (not included) in that order on the NQPACK048SD on the user system. Then secure the screws.

Before using the M30262T-PTC, be sure to read "9. Precautions" (page 4). And, read the user's manual of an emulator for M16C/62P.

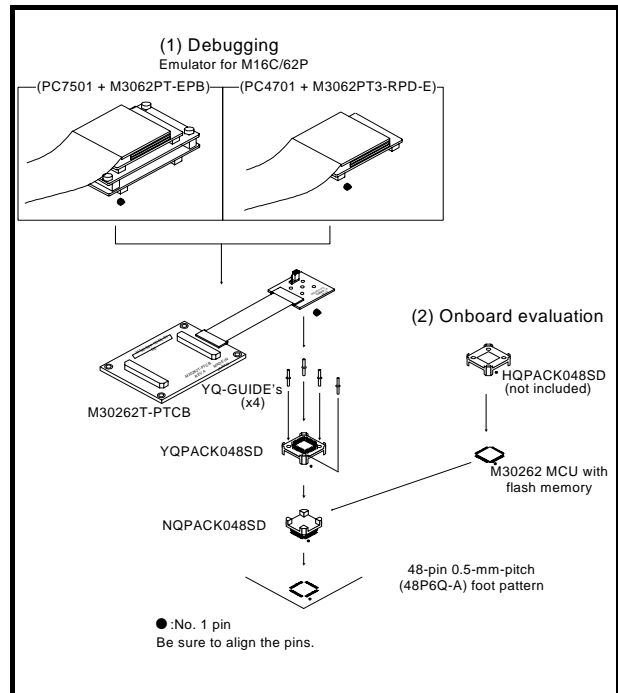

Figure 2 Usage of the M30262T-PTC

## 5. Hardware Configuration of the M30262T-PTC (See Figure 3)

Hardware configuration of the M30262T-PTC is shown below.

- (1) Connector  
Connector for the emulator for M16C/62P (M3062PT-EPB).
- (2) Cable  
Flat cable which connects the user system flexibly (Length: 150 mm).
- (3) Target interface  
Interface which has a connector for a user system and jumper switch JP1.

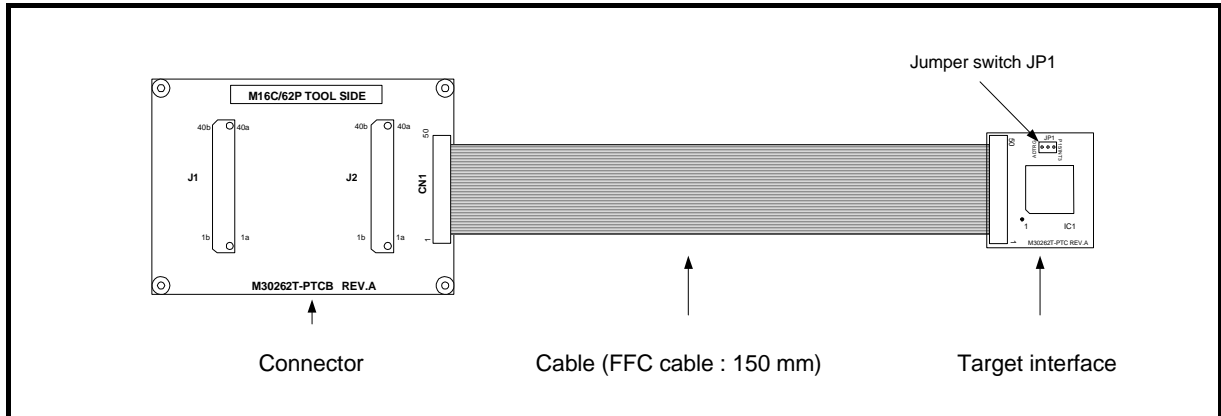

Figure 3 Hardware configuration of the M30262T-PTC

## 6. Connection Procedure (see Figure 4)

The procedure for connecting the M30262T-PTC is shown below.

- (1) Mount the NQPACK048SD.
- (2) Mount the YQPACK048SD on the NQPACK048SD.
- (3) Secure the four corners of the YQPACK048SD with the YQ-GUIDE's.

Do NOT use the screws in the YQPACK048SD package.

Do NOT use the screwdriver in the NQPACK048SD package for securing YQ-GUIDE's (used for securing YQPACK048SD).

- (4) Attach the M30262T-PTC to the YQPACK048SD.
- (5) Connect the emulator for M16C/62P to the M30262T-PTC.

## 7. Switch Settings

When you use No. 36 pin (Port P1<sub>5</sub>/INT<sub>3</sub>/ADTRG), set switch JP1 according to port functions.

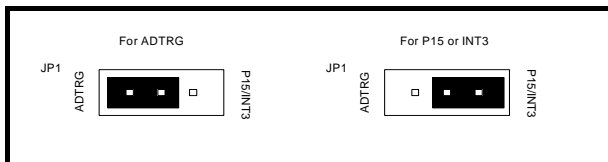

Figure 5 JP1 Settings

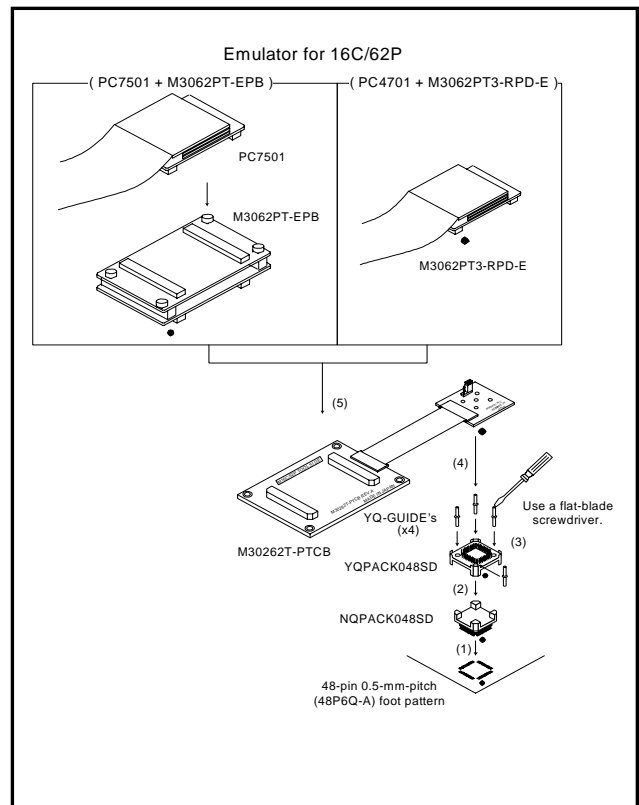

Figure 4 Connection Procedure

## 8. External Dimensions of the M30262T-PTC (Connector) and a Sample Foot Pattern (see Figure 6)

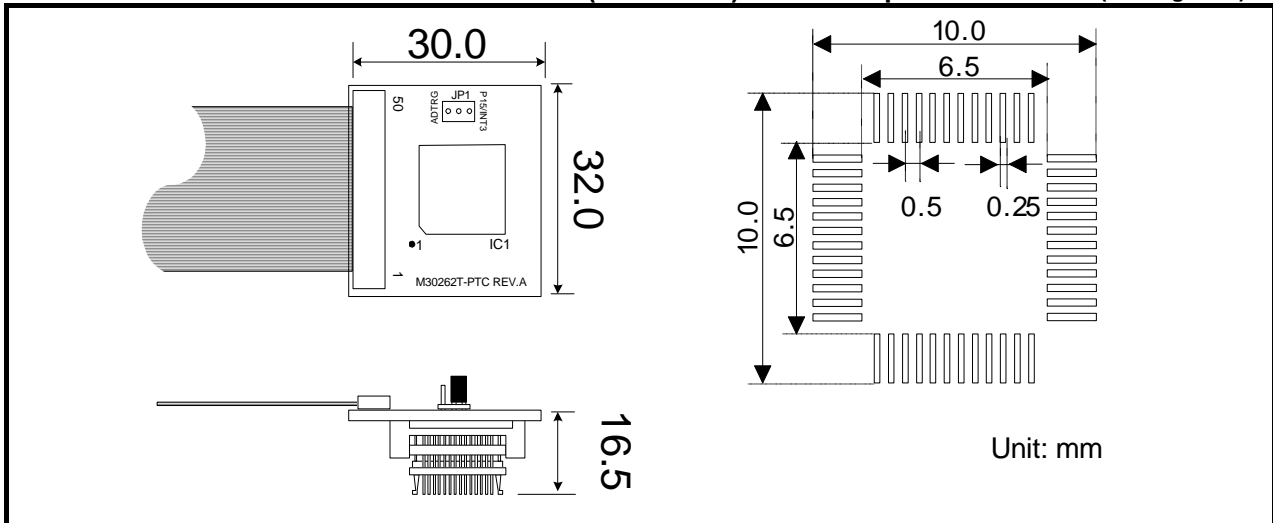

Figure 6 External dimensions of M30262T-PTC and sample foot pattern

## 9. Precautions

### ⚠ CAUTION

#### ! Cautions for Debugging M16C/262 with an Emulator for M16C/62P:



- The cautions for software development of M16C/26 using the emulator for M16C/62P (M3062PT-EPB or M3062PT3-RPD-E) are as follows.
  - (1) **NMI\***  
M16C/26: NMI\* is disabled after reset. Set the P8<sub>5</sub>/NMI\* function select bit (bit 4 of address 001E<sub>16</sub>) to "1" to use the NMI\* interrupt.  
M16C/62P: NMI\* is enabled after reset.
  - (2) **Port P8<sub>5</sub>**  
M16C/26: Port P8<sub>5</sub> has direction and pull-up control registers.  
M16C/62P: Port P8<sub>5</sub> functions only as an input port. Thus, debugging of port P8<sub>5</sub> output and pull-up functions cannot be performed with the M16C/62P tool.
  - (3) **Flash memory suspend mod**  
M16C/62P flash memory does not support the M16C/26 suspension mode. Thus, debugging of the suspension function cannot be performed with the M16C/62P tool.
- When starting up a debugger (M3T-PD30F or M3T-PD30), select the following MCU file according to the emulator for M16C/62P.
  - (1) When you start up the M3T-PD30F using the PC7501 + M3062PT-EPB, select "M16C62P.mcu".
  - (2) When you start up the M3T-PD30 using the PC4701 + M3062PT3-RPD-E, select "M3062PT3.mcu".

### IMPORTANT

#### Notes on This Product:

- When connecting the M30262T-PTC, be sure to use the included YQ-GUIDE's
- Do not use the screws included with the YQPACK048SD for connecting the YQPACK048SD
- We cannot accept any request for repair.
- For purchasing the NQPACK048SD, YQPACK048SD and HQPACK048SD, contact the following:  
Daimaru Kogyo Ltd. <http://www.daimarukogyo.co.jp/>  
Tokyo Eletech Corporation [http://www.tetc.co.jp/e\\_tet.htm](http://www.tetc.co.jp/e_tet.htm)
- For inquiries about the product or the contents of this manual, contact your local distributor.  
Renesas Tools Homepage <http://www.renesas.com/en/tools>