

To our customers,

Old Company Name in Catalogs and Other Documents

On April 1st, 2010, NEC Electronics Corporation merged with Renesas Technology Corporation, and Renesas Electronics Corporation took over all the business of both companies. Therefore, although the old company name remains in this document, it is a valid Renesas Electronics document. We appreciate your understanding.

Renesas Electronics website: <http://www.renesas.com>

April 1st, 2010
Renesas Electronics Corporation

Issued by: Renesas Electronics Corporation (<http://www.renesas.com>)

Send any inquiries to <http://www.renesas.com/inquiry>.

Notice

1. All information included in this document is current as of the date this document is issued. Such information, however, is subject to change without any prior notice. Before purchasing or using any Renesas Electronics products listed herein, please confirm the latest product information with a Renesas Electronics sales office. Also, please pay regular and careful attention to additional and different information to be disclosed by Renesas Electronics such as that disclosed through our website.
2. Renesas Electronics does not assume any liability for infringement of patents, copyrights, or other intellectual property rights of third parties by or arising from the use of Renesas Electronics products or technical information described in this document. No license, express, implied or otherwise, is granted hereby under any patents, copyrights or other intellectual property rights of Renesas Electronics or others.
3. You should not alter, modify, copy, or otherwise misappropriate any Renesas Electronics product, whether in whole or in part.
4. Descriptions of circuits, software and other related information in this document are provided only to illustrate the operation of semiconductor products and application examples. You are fully responsible for the incorporation of these circuits, software, and information in the design of your equipment. Renesas Electronics assumes no responsibility for any losses incurred by you or third parties arising from the use of these circuits, software, or information.
5. When exporting the products or technology described in this document, you should comply with the applicable export control laws and regulations and follow the procedures required by such laws and regulations. You should not use Renesas Electronics products or the technology described in this document for any purpose relating to military applications or use by the military, including but not limited to the development of weapons of mass destruction. Renesas Electronics products and technology may not be used for or incorporated into any products or systems whose manufacture, use, or sale is prohibited under any applicable domestic or foreign laws or regulations.
6. Renesas Electronics has used reasonable care in preparing the information included in this document, but Renesas Electronics does not warrant that such information is error free. Renesas Electronics assumes no liability whatsoever for any damages incurred by you resulting from errors in or omissions from the information included herein.
7. Renesas Electronics products are classified according to the following three quality grades: “Standard”, “High Quality”, and “Specific”. The recommended applications for each Renesas Electronics product depends on the product’s quality grade, as indicated below. You must check the quality grade of each Renesas Electronics product before using it in a particular application. You may not use any Renesas Electronics product for any application categorized as “Specific” without the prior written consent of Renesas Electronics. Further, you may not use any Renesas Electronics product for any application for which it is not intended without the prior written consent of Renesas Electronics. Renesas Electronics shall not be in any way liable for any damages or losses incurred by you or third parties arising from the use of any Renesas Electronics product for an application categorized as “Specific” or for which the product is not intended where you have failed to obtain the prior written consent of Renesas Electronics. The quality grade of each Renesas Electronics product is “Standard” unless otherwise expressly specified in a Renesas Electronics data sheets or data books, etc.
 - “Standard”: Computers; office equipment; communications equipment; test and measurement equipment; audio and visual equipment; home electronic appliances; machine tools; personal electronic equipment; and industrial robots.
 - “High Quality”: Transportation equipment (automobiles, trains, ships, etc.); traffic control systems; anti-disaster systems; anti-crime systems; safety equipment; and medical equipment not specifically designed for life support.
 - “Specific”: Aircraft; aerospace equipment; submersible repeaters; nuclear reactor control systems; medical equipment or systems for life support (e.g. artificial life support devices or systems), surgical implantations, or healthcare intervention (e.g. excision, etc.), and any other applications or purposes that pose a direct threat to human life.
8. You should use the Renesas Electronics products described in this document within the range specified by Renesas Electronics, especially with respect to the maximum rating, operating supply voltage range, movement power voltage range, heat radiation characteristics, installation and other product characteristics. Renesas Electronics shall have no liability for malfunctions or damages arising out of the use of Renesas Electronics products beyond such specified ranges.
9. Although Renesas Electronics endeavors to improve the quality and reliability of its products, semiconductor products have specific characteristics such as the occurrence of failure at a certain rate and malfunctions under certain use conditions. Further, Renesas Electronics products are not subject to radiation resistance design. Please be sure to implement safety measures to guard them against the possibility of physical injury, and injury or damage caused by fire in the event of the failure of a Renesas Electronics product, such as safety design for hardware and software including but not limited to redundancy, fire control and malfunction prevention, appropriate treatment for aging degradation or any other appropriate measures. Because the evaluation of microcomputer software alone is very difficult, please evaluate the safety of the final products or system manufactured by you.
10. Please contact a Renesas Electronics sales office for details as to environmental matters such as the environmental compatibility of each Renesas Electronics product. Please use Renesas Electronics products in compliance with all applicable laws and regulations that regulate the inclusion or use of controlled substances, including without limitation, the EU RoHS Directive. Renesas Electronics assumes no liability for damages or losses occurring as a result of your noncompliance with applicable laws and regulations.
11. This document may not be reproduced or duplicated, in any form, in whole or in part, without prior written consent of Renesas Electronics.
12. Please contact a Renesas Electronics sales office if you have any questions regarding the information contained in this document or Renesas Electronics products, or if you have any other inquiries.

(Note 1) “Renesas Electronics” as used in this document means Renesas Electronics Corporation and also includes its majority-owned subsidiaries.

(Note 2) “Renesas Electronics product(s)” means any product developed or manufactured by or for Renesas Electronics.

PCA7438F-80A

PCA7438L-80A

User's Manual

PROM Programming Adapter for M38B59EFP/
M38B59EFS

* IC51-0804-819-6 and IC51-0804-890 are products of Yamaichi Electronics Co., Ltd.
* R4944A, R4945 and R4945A are trademarks of Advantest Corporation.

Keep safety first in your circuit designs!

- Renesas Technology Corporation and Renesas Solutions Corporation put the maximum effort into making semiconductor products better and more reliable, but there is always the possibility that trouble may occur with them. Trouble with semiconductors may lead to personal injury, fire or property damage. Remember to give due consideration to safety when making your circuit designs, with appropriate measures such as (i) placement of substitutive, auxiliary circuits, (ii) use of nonflammable material or (iii) prevention against any malfunction or mishap.

Notes regarding these materials

- These materials are intended as a reference to assist our customers in the selection of the Renesas Technology product best suited to the customer's application; they do not convey any license under any intellectual property rights, or any other rights, belonging to Renesas Technology Corporation, Renesas Solutions Corporation or a third party.
- Renesas Technology Corporation and Renesas Solutions Corporation assume no responsibility for any damage, or infringement of any third-party's rights, originating in the use of any product data, diagrams, charts, programs, algorithms, or circuit application examples contained in these materials.
- All information contained in these materials, including product data, diagrams, charts, programs and algorithms represents information on products at the time of publication of these materials, and are subject to change by Renesas Technology Corporation and Renesas Solutions Corporation without notice due to product improvements or other reasons. It is therefore recommended that customers contact Renesas Technology Corporation, Renesas Solutions Corporation or an authorized Renesas Technology product distributor for the latest product information before purchasing a product listed herein. The information described here may contain technical inaccuracies or typographical errors. Renesas Technology Corporation and Renesas Solutions Corporation assume no responsibility for any damage, liability, or other loss rising from these inaccuracies or errors. Please also pay attention to information published by Renesas Technology Corporation and Renesas Solutions Corporation by various means, including the Renesas home page (<http://www.renesas.com>).
- When using any or all of the information contained in these materials, including product data, diagrams, charts, programs, and algorithms, please be sure to evaluate all information as a total system before making a final decision on the applicability of the information and products. Renesas Technology Corporation and Renesas Solutions Corporation assume no responsibility for any damage, liability or other loss resulting from the information contained herein.
- Renesas Technology semiconductors are not designed or manufactured for use in a device or system that is used under circumstances in which human life is potentially at stake. Please contact Renesas Technology Corporation, Renesas Solutions Corporation or an authorized Renesas Technology product distributor when considering the use of a product contained herein for any specific purposes, such as apparatus or systems for transportation, vehicular, medical, aerospace, nuclear, or undersea repeater use.
- The prior written approval of Renesas Technology Corporation and Renesas Solutions Corporation is necessary to reprint or reproduce in whole or in part these materials.
- If these products or technologies are subject to the Japanese export control restrictions, they must be exported under a license from the Japanese government and cannot be imported into a country other than the approved destination. Any diversion or reexport contrary to the export control laws and regulations of Japan and/or the country of destination is prohibited.
- Please contact Renesas Technology Corporation or Renesas Solutions Corporation for further details on these materials or the products contained therein.

Precautions to be taken when using this product

- This product is a development supporting unit for use in your program development and evaluation stages. In mass-producing your program you have finished developing, be sure to make a judgment on your own risk that it can be put to practical use by performing integration test, evaluation, or some experiment else.
- In no event shall Renesas Solutions Corporation be liable for any consequence arising from the use of this product.
- Renesas Solutions Corporation strives to renovate or provide a workaround for product malfunction at some charge or without charge. However, this does not necessarily mean that Renesas Solutions Corporation guarantees the renovation or the provision under any circumstances.
- This product has been developed by assuming its use for program development and evaluation in laboratories. Therefore, it does not fall under the application of Electrical Appliance and Material Safety Law and protection against electromagnetic interference when used in Japan.

Renesas Tools Homepage <http://www.renesas.com/en/tools>

Contents

1. Precautions for Safety	4
1.1 Safety Symbols and Meanings	4
2. Introduction	6
2.1 Things to Check When Unpacking	6
3. Specifications	7
4. How to Write the Program	8
4.1 Programming Procedures	8
4.2 Selecting a PROM Programmer Connector	9
4.3 Setting the Jumper Switches	10
4.4 Attaching the Adapter to a PROM Programmer	11
4.5 Inserting an MCU into the Programming Adapter	12
4.6 Precautions When Opening and Closing the IC Socket	12
4.7 Precautions When Handling the Adapter	12
4.8 Setting a Programming Area	13
5. Recommended PROM Programmers	13
6. How to Request for Support	13
7. Memory Maps	14

To Use the Product Properly

Precautions for Safety:





- Either in the User's Manual or on the product, several icons are used to insure proper handling of this product and also to prevent injuries to you or other persons, or damage to your properties.
- Their graphic images and meanings are given in Chapter 1, Precautions for Safety. Be sure to read this chapter before using the product.

1. Precautions for Safety

In this user's manual, several icons are used to insure proper handling of this product and also to prevent injuries to you or other persons, or damage to your properties.

This chapter describes precautions which should be taken in order to use this product safely and properly. Be sure to read this chapter before using this product.

1.1 Safety Symbols and Meanings

	WARNING	If the requirements shown in the "WARNING" sentences are ignored, the equipment may cause serious personal injury or death.
	CAUTION	If the requirements shown in the "CAUTION" sentences are ignored, the equipment may malfunction.
	IMPORTANT	It means important information on using this product.

In addition to the three above, the following are also used as appropriate.

△ means WARNING or CAUTION.
Example:  **CAUTION AGAINST AN ELECTRIC SHOCK**

⊘ means PROHIBITION.
Example:  **DISASSEMBLY PROHIBITED**

● means A FORCIBLE ACTION.
Example:  **UNPLUG THE POWER CABLE FROM THE RECEPTACLE.**

The following pages describe the symbols "WARNING", "CAUTION", and "IMPORTANT".

WARNING

Warnings for Use Environment:

- This equipment is to be used in an environment with a maximum ambient temperature of 35°C. Care should be taken that this temperature is not exceeded.
- Select the proper programming mode of the PROM programmer.

CAUTION

Cautions in Handling This Product:



- Do not disassemble or modify this product. Personal injury due to electric shock may occur if this product is disassembled or modified.
- Use caution when handling this product. Be careful not to apply a mechanical shock such as falling, etc.
- Do not directly touch the connector pins of this product.
- Be careful with the static electricity when handling this product and the MCU.

Caution in Keeping This Product:

- When not using this product for a long time:
 - (1) Attach the connector pins of this product to the conductive sponge.
 - (2) Put it into a conductive polyvinyl, and keep it in the package case shipped from the factory.
 - (3) Store it in the place where humidity and temperature are low and direct sunshine does not strike.

IMPORTANT

When Using this Product:

- Attach this product to the IC socket on the PROM programmer properly.
- Insert the MCU to the IC socket of this product properly.
- When opening and closing the IC socket, hold the adapter horizontally.
- Be sure to set the programming area as described in this user's manual.
- Do not use the PROM programmer's device identification code readout function.

2. Introduction

The PCA7438F-80A and PCA7438L-80A are PROM programming adapters for 8-bit 38000 Series MCUs. These adapters are tools that can be used to write a program into internal PROM of MCUs using a commercially available PROM programmer.

This manual describes the specifications and the operation of the PCA7438F-80A/PCA7438L-80A.

Figure 2.1 shows the external view and the constituent parts of them.

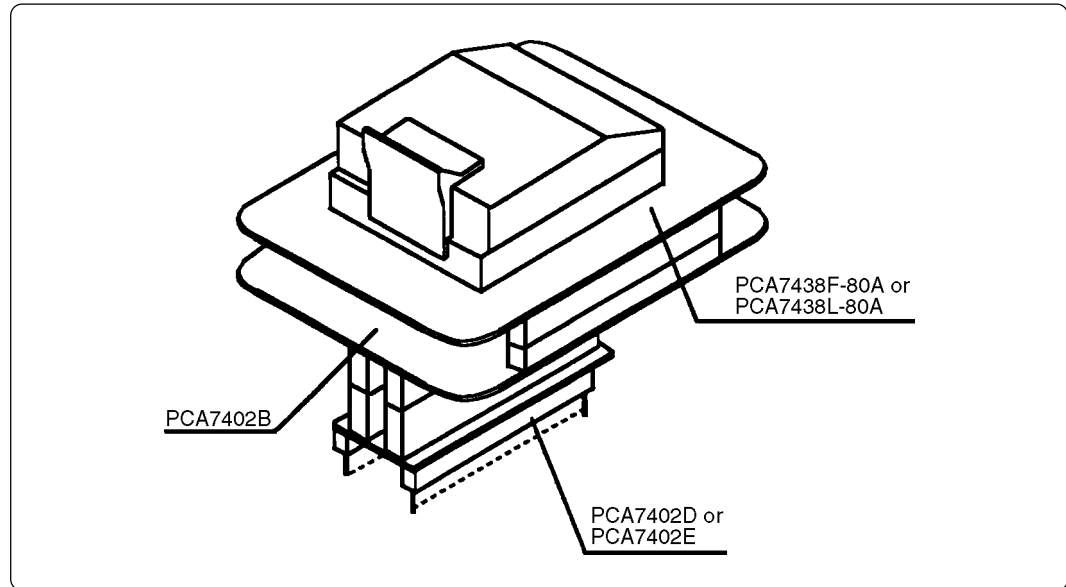

Figure 2.1 External view of the PCA7438F-80A/PCA7438L-80A and their constituent parts

2.1 Things to Check When Unpacking

The PCA7438F-80A/PCA7438L-80A consist of the following items. Check to see that it contains all of the components shown in Table 2.1.

Table 2.1 Contents of the PCA7438F-80A/PCA7438L-80A

Main unit	PCA7438F-80A/PCA7438L-80A
Interface unit	PCA7402B
PROM programmer connector	PCA7402D (28-pin) PCA7402E (32-pin)
User's Manual	This user's manual

If any part is missing or there is any doubt about your product package, contact your local distributor.

3. Specifications

Tables 3.1 and 3.2 list the specifications of the PCA7438F-80A and PCA7438L-80A respectively.

Table 3.1 Common specifications of the PCA7438F-80A

Applicable MCU		M38B59EFFF
Operating clock frequency		4 MHz (Supplied by the ceramic oscillator mounted on the PCA7438F-80A)
Power supply		Supplied from the Vcc of the PROM programmer
MCU socket		IC51-0804-819-6 (made by Yamaichi Electronics Co., Ltd.)
Board configuration	PCA7438F-80A	A programmable MCU mounted (IC socket for 80-pin QFP mounted)
	PCA7402B	Interface board (buffer IC mounted) (Connected by two rows of standard-pitch 18-pin connectors and two rows of standard-pitch 16-pin connectors to the upper and lower boards)
	PCA7402D	Board to be connected to the PROM programmer (for 256K bit mode) (Standard-pitch 28-pin pin-header to be connected to the PROM programmer mounted)
	PCA7402E	Board to be connected to the PROM programmer (for 1M bit mode) (Standard-pitch 32-pin pin-header to be connected to the PROM programmer mounted)

Note: The PCA7438F-80A is designed to support 38000 Series 80-pin QFP packages (80P6N-A), and it is basically compatible with the future variations of the MCU series.

Table 3.1 Common specifications of the PCA7438L-80A

Applicable MCU		M38B59EFFS
Operating clock frequency		4 MHz (Supplied by the ceramic oscillator mounted on the PCA7438L-80A)
Power supply		Supplied from the Vcc of the PROM programmer
MCU socket		IC51-0804-890 (made by Yamaichi Electronics Co., Ltd.)
Board configuration	PCA7438L-80A	A programmable MCU mounted (IC socket for 80-pin LCC mounted)
	PCA7402B	Interface board (buffer IC mounted) (Connected by two rows of standard-pitch 18-pin connectors and two rows of standard-pitch 16-pin connectors to the upper and lower boards)
	PCA7402D	Board to be connected to the PROM programmer (for 256K bit mode) (Standard-pitch 28-pin pin-header to be connected to the PROM programmer mounted)
	PCA7402E	Board to be connected to the PROM programmer (for 1M bit mode) (Standard-pitch 32-pin pin-header to be connected to the PROM programmer mounted)

Note: The PCA7438L-80A is designed to support 38000 Series 80-pin LCC packages (80D0), and it is basically compatible with the future variations of the MCU series.

4. How to Write the Program

This chapter describes how to write programs using a PROM programmer. For details on how to operate the PROM programmer, refer to the user's manual of the PROM programmer.

4.1 Programming Procedures

Follow procedures (1) to (9) to write programs into the MCU.

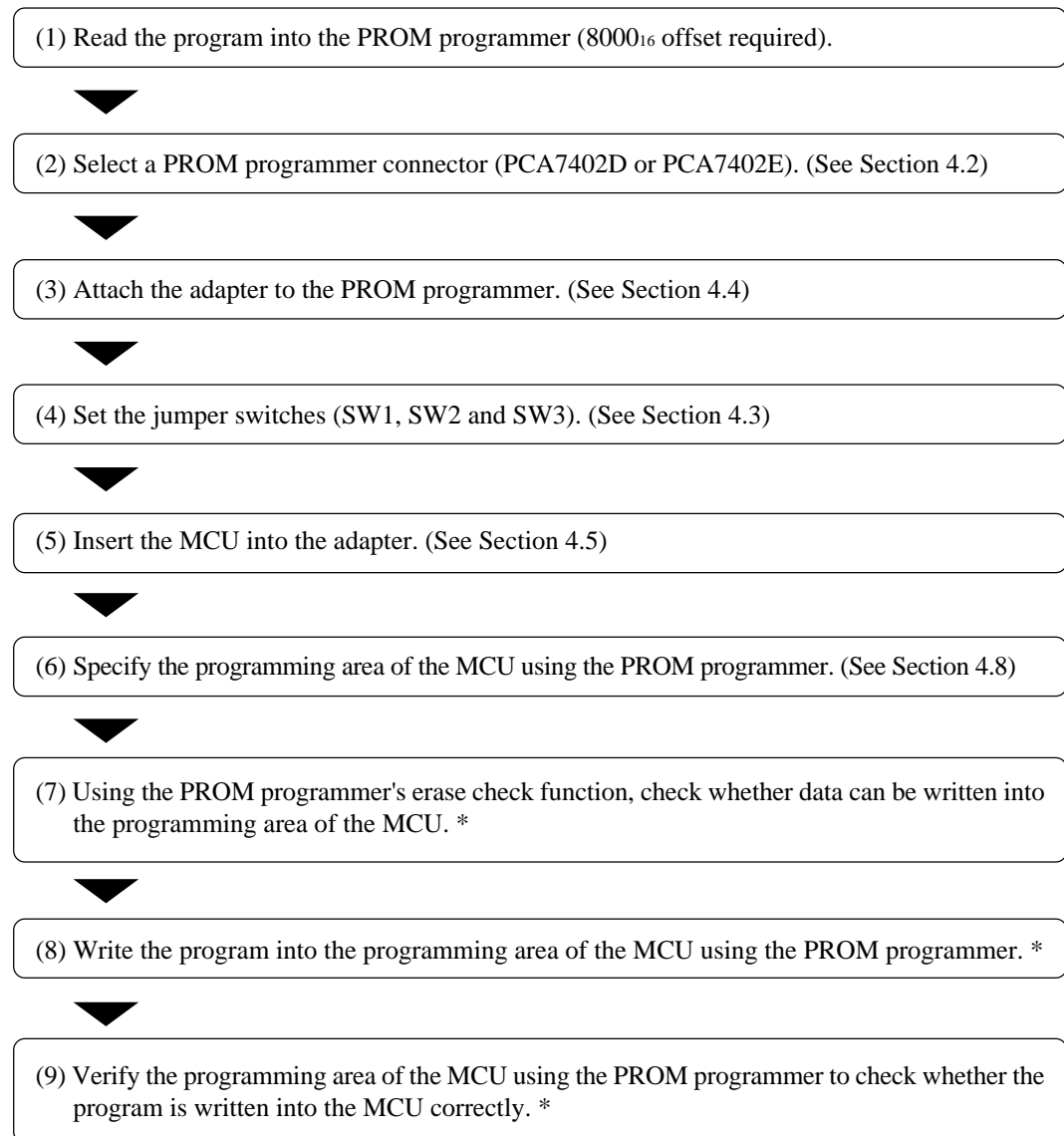

Notes:

* Some PROM programmers perform the steps (7) through (9) automatically.

* **Be sure to set the programming area. Otherwise the mode's shift to the programming mode may not be performed successfully. The erase check function etc. may not also be performed completely.**

4.2 Selecting a PROM Programmer Connector

Select a PROM programmer connector (PCA7402D or PCA7402E) according to the ROM capacity of your MCU.

- (1) For MCU 32KB or less: PCA7402D (for 256K bit mode)
 - (2) For MCU 32KB or more: PCA7402E (for 1M bit mode)
- e.g.) For the M38B59EFP and M38B59EFS, use the PCA7402E.

Figure 4.1 shows the PROM programmer connectors.

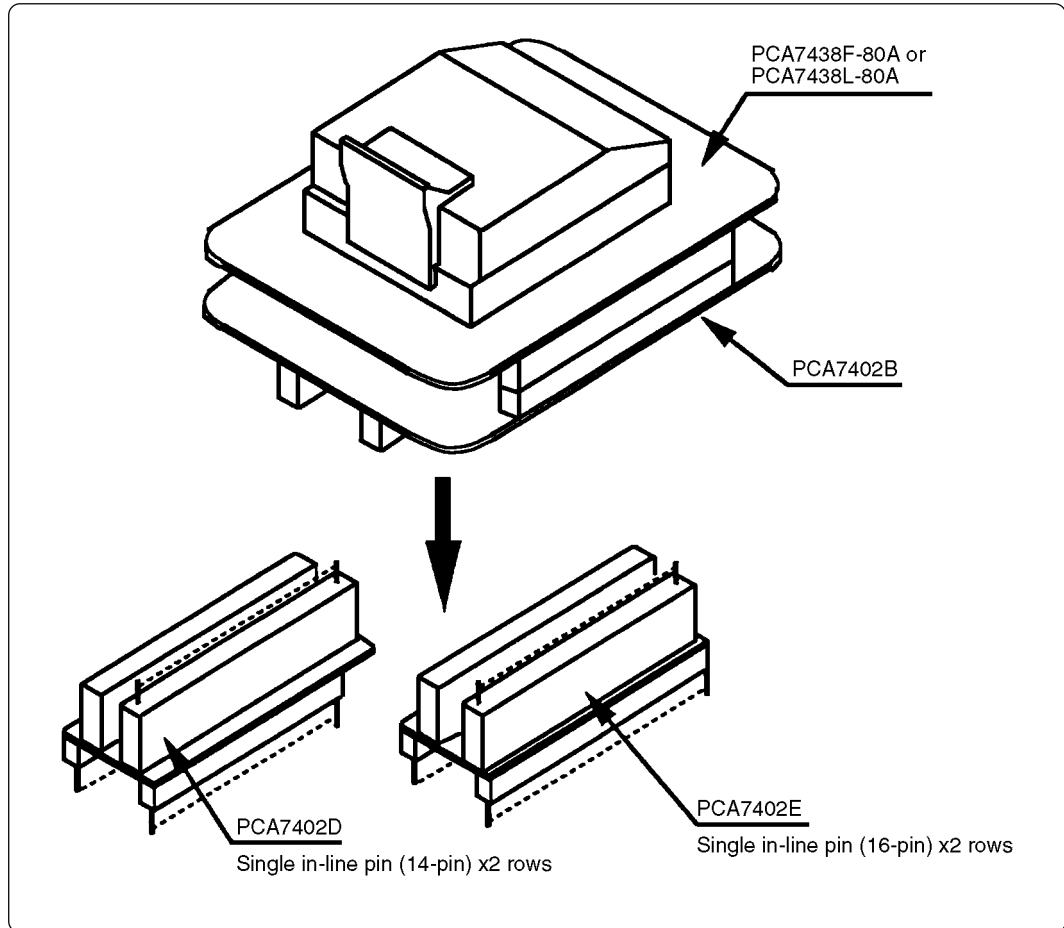

Figure 4.1 Selecting a PROM programmer connector

4.3 Setting the Jumper Switches

(1) Jumper switch SW1

Set the SW1 according to the output type of MCU's ports P2₀ - P2₃ (data buses D0-D3, No. 64-61 pins). For setting, see Table 4.1 and Figure 4.2.

- Ports P2₀ - P2₃: CMOS output SW1: CMOS
- Ports P2₀ - P2₃: Pch output SW1: Pch
- Ports P2₀ - P2₃: Nch output SW1: Nch

(2) Jumper switch SW2

Set the SW2 according to the output type of MCU's ports P2₄ - P2₇ (data buses D4-D7, No. 60-57 pins). For setting, see Table 4.1 and Figure 4.2.

- Ports P2₄ - P2₇: CMOS output SW2: CMOS
- Ports P2₄ - P2₇: Pch output SW2: Pch
- Ports P2₄ - P2₇: Nch output SW2: Nch

(3) Jumper switch SW3

How to set the SW3 is shown below.

- When No. 12 pin of the MCU is dedicated to pin X_{CIN} SW3: ON
- When pin X_{CIN} also serves as an I/O port (e.g. P4_I/X_{CIN}) SW3: OFF
- When there is no pin X_{CIN} SW3: OFF

Table 4.1 Jumper switch settings

MCU	Example	SW1	SW2	SW3
M38B5XEXFP	M38B59EFP	Pch	Pch	OFF
M38B5XEXFS	M38B59EFS			

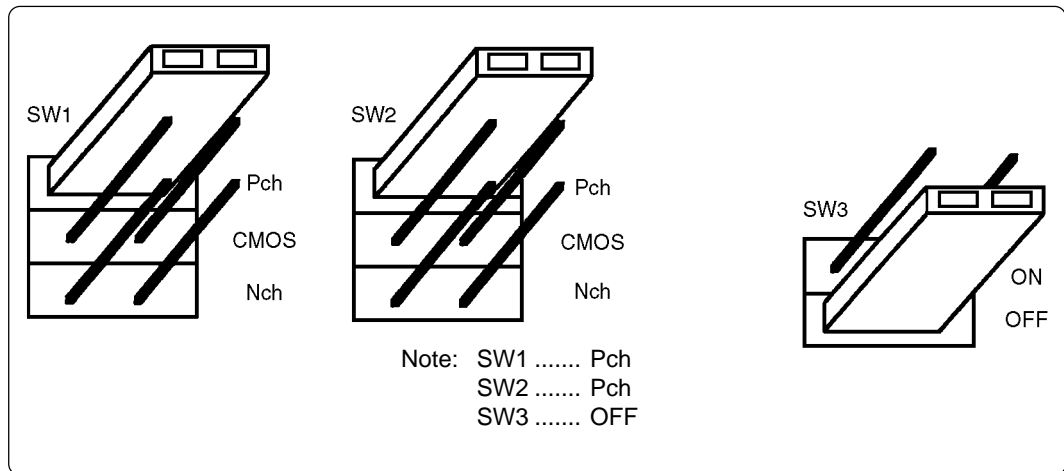

Figure 4.2 Jumper switch settings

4.4 Attaching the Adapter to a PROM Programmer

(1) For the PCA7402D

Attach the pin No. 1 of the PCA7402D PROM programmer connector (standard-pitch 28-pin pin-header mounted) to the pin No. 1 of the IC socket of the PROM programmer.

Be careful when attaching the adapter because incorrect insertion can cause fatal damage to the MCU.

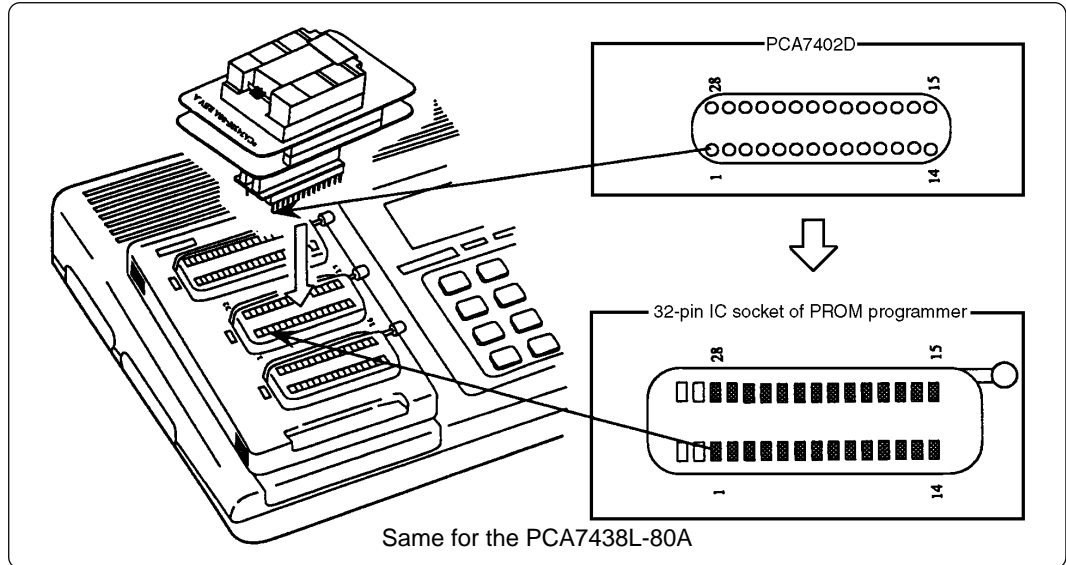

Figure 4.3 Attaching the adapter to the PROM programmer (PCA7402D)

(2) For the PCA7402E

Attach the pin No. 1 of the PCA7402E PROM programmer connector (standard-pitch 32-pin pin-header mounted) to the pin No. 1 of the IC socket of the PROM programmer.

Be careful when attaching the adapter because incorrect insertion can cause fatal damage to the MCU.

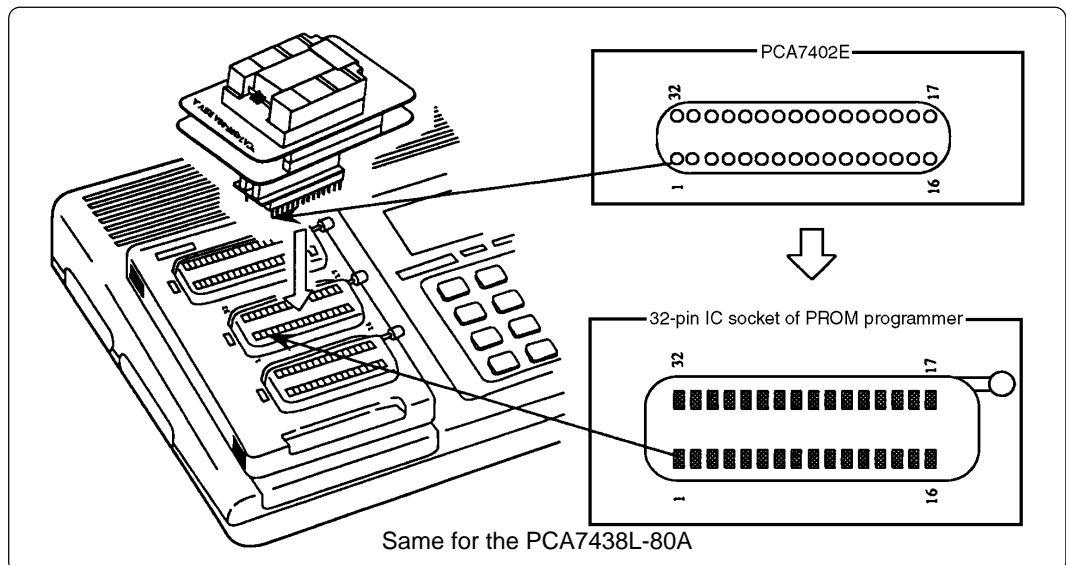

Figure 4.4 Attaching the adapter to the PROM programmer (PCA7402E)

4.5 Inserting an MCU into the Programming Adapter

As shown in Figure 4.5, insert the MCU into the IC socket, with the pin No. 1 of the MCU matched to the pin No. 1 of the IC socket on the PCA7438F-80A/PCA7438L-80A.

Be careful when inserting the MCU because incorrect insertion can cause fatal damage to the MCU.

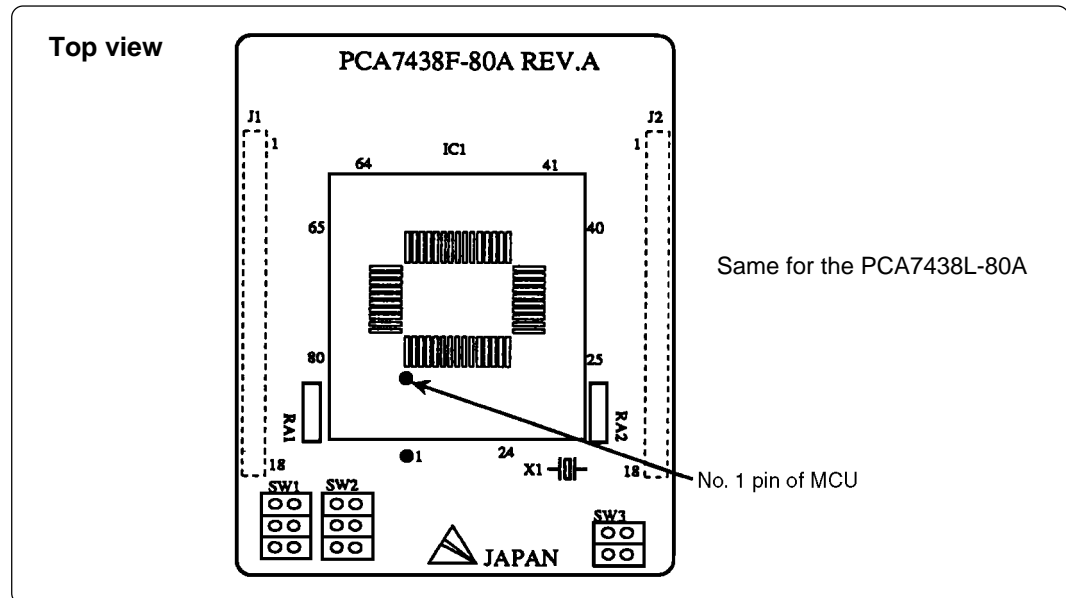

Figure 4.5 Inserting an MCU

4.6 Precautions When Opening and Closing the IC Socket

When opening and closing the IC socket, hold the adapter horizontally as shown in Figure 4.6. Otherwise the inside of the IC socket may become damaged and cause an electrical insulation failure.

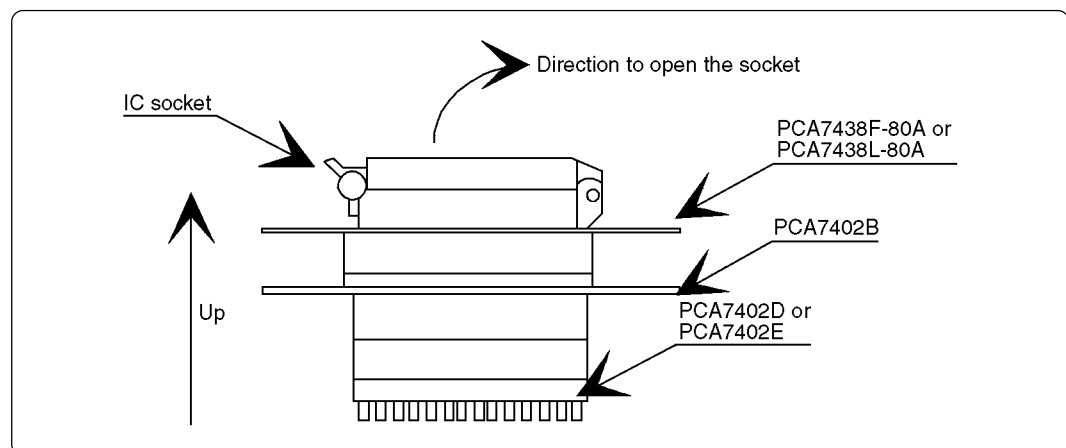

Figure 4.6 Holding the adapter in a horizontal position

4.7 Precautions When Handling the Adapter

Do not touch the connector in the IC socket and the pins on the PROM programmer connector, otherwise it cause an electrical insulation failure because of dirt.

When not using, attach the connector pins of this product to the conductive sponge as it was shipped from the factory.

4.8 Setting a Programming Area

When writing the program into the MCU, be sure to set the programming area. And also, specify its device of the PROM programmer.

Table 4.2 Programming area

MCU type	MCU area	PROM programmer		Programming area of the MCU
		Device name	Programming area	
M38B59EFPF M38B59EFPF	Internal ROM area	M5M27C101	01080 ₁₆ - 0FFFD ₁₆	1080 ₁₆ - FFFD ₁₆

5. Recommended PROM Programmers

The PROM programmers listed in Table 5.1 are recommended for this product. Using the actual products, we have verified that these PROM programmers can be used to write programs without problem. Nonconformity occurring by using any other PROM programmers can not be supported. For the latest type of PROM programmers, contact the manufacturer to confirm whether it can be used for your product.

Table 5.1 Recommended PROM programmers

Manufacturer	Type name	Device name	Programming voltage (Vpp)
Advantest	R4944A	M5M27C101 mode	12.5 V
	R4945		
	R4945A		

* Be sure to select "Mitsubishi" when specifying the manufacturer for the device.

6. How to Request for Support

After checking this manual, fill in the following information and email to your local distributor.

For prompt response, please specify the following information:

(1) Contact address

- Company name
- Department
- Responsible person
- Phone number
- Fax number
- E-mail address

(2) Product information

- Name of the programming adapter
- Serial number
- Date of purchase
- Target MCU
- Symptoms (Fails blank check/Cannot write a program/Fails verification etc.)
- Detailed symptoms
- How often does the problem occur? (2 out of 10 etc.)
- When did the problem start to occur? (Since purchase/Used to work correctly)
- Type name of the PROM programmer (Advantest R4945A etc.)
- Specified device when writing to PROM (M27C101 etc.)
- Specified programming area when writing to PROM
- Switch settings of the adapter when writing to PROM

7. Memory Maps

Figure 7.1 shows memory maps of the MCU and the PROM programmer.

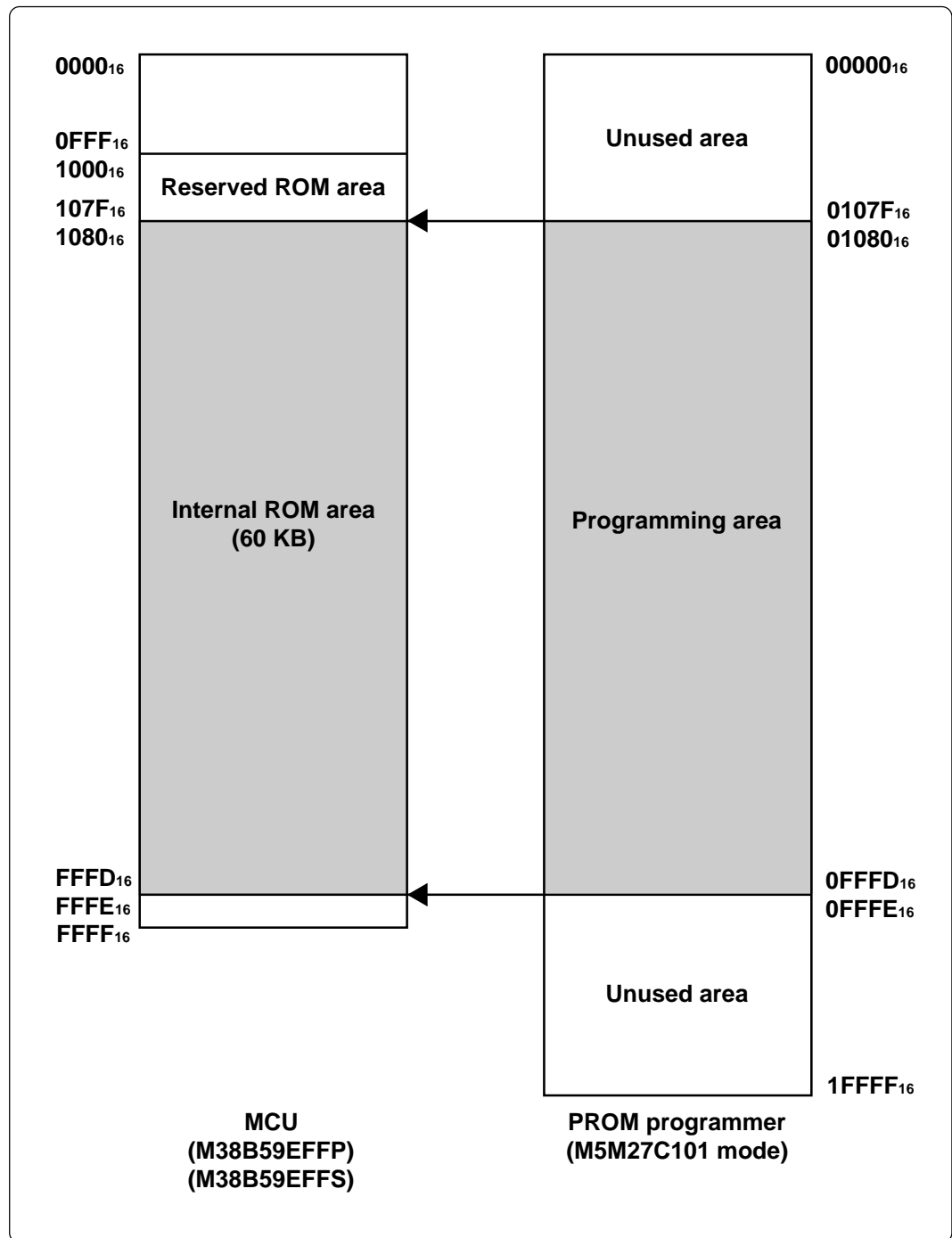

Figure 7.1 Memory maps

PCA7438F-80A/PCA7438L-80A User's Manual

Rev.1.00
August 1, 2003
REJ10J0245-0100Z

COPYRIGHT ©2003 RENESAS TECHNOLOGY CORPORATION
AND RENESAS SOLUTIONS CORPORATION ALL RIGHTS RESERVED

PCA7438F-80A PCA7438L-80A
User's Manual



Renesas Electronics Corporation

1753, Shimonumabe, Nakahara-ku, Kawasaki-shi, Kanagawa 211-8668 Japan

REJ10J0245-0100Z