

To our customers,

Old Company Name in Catalogs and Other Documents

On April 1st, 2010, NEC Electronics Corporation merged with Renesas Technology Corporation, and Renesas Electronics Corporation took over all the business of both companies. Therefore, although the old company name remains in this document, it is a valid Renesas Electronics document. We appreciate your understanding.

Renesas Electronics website: <http://www.renesas.com>

April 1st, 2010
Renesas Electronics Corporation

Issued by: Renesas Electronics Corporation (<http://www.renesas.com>)

Send any inquiries to <http://www.renesas.com/inquiry>.

Notice

1. All information included in this document is current as of the date this document is issued. Such information, however, is subject to change without any prior notice. Before purchasing or using any Renesas Electronics products listed herein, please confirm the latest product information with a Renesas Electronics sales office. Also, please pay regular and careful attention to additional and different information to be disclosed by Renesas Electronics such as that disclosed through our website.
2. Renesas Electronics does not assume any liability for infringement of patents, copyrights, or other intellectual property rights of third parties by or arising from the use of Renesas Electronics products or technical information described in this document. No license, express, implied or otherwise, is granted hereby under any patents, copyrights or other intellectual property rights of Renesas Electronics or others.
3. You should not alter, modify, copy, or otherwise misappropriate any Renesas Electronics product, whether in whole or in part.
4. Descriptions of circuits, software and other related information in this document are provided only to illustrate the operation of semiconductor products and application examples. You are fully responsible for the incorporation of these circuits, software, and information in the design of your equipment. Renesas Electronics assumes no responsibility for any losses incurred by you or third parties arising from the use of these circuits, software, or information.
5. When exporting the products or technology described in this document, you should comply with the applicable export control laws and regulations and follow the procedures required by such laws and regulations. You should not use Renesas Electronics products or the technology described in this document for any purpose relating to military applications or use by the military, including but not limited to the development of weapons of mass destruction. Renesas Electronics products and technology may not be used for or incorporated into any products or systems whose manufacture, use, or sale is prohibited under any applicable domestic or foreign laws or regulations.
6. Renesas Electronics has used reasonable care in preparing the information included in this document, but Renesas Electronics does not warrant that such information is error free. Renesas Electronics assumes no liability whatsoever for any damages incurred by you resulting from errors in or omissions from the information included herein.
7. Renesas Electronics products are classified according to the following three quality grades: “Standard”, “High Quality”, and “Specific”. The recommended applications for each Renesas Electronics product depends on the product’s quality grade, as indicated below. You must check the quality grade of each Renesas Electronics product before using it in a particular application. You may not use any Renesas Electronics product for any application categorized as “Specific” without the prior written consent of Renesas Electronics. Further, you may not use any Renesas Electronics product for any application for which it is not intended without the prior written consent of Renesas Electronics. Renesas Electronics shall not be in any way liable for any damages or losses incurred by you or third parties arising from the use of any Renesas Electronics product for an application categorized as “Specific” or for which the product is not intended where you have failed to obtain the prior written consent of Renesas Electronics. The quality grade of each Renesas Electronics product is “Standard” unless otherwise expressly specified in a Renesas Electronics data sheets or data books, etc.
 - “Standard”: Computers; office equipment; communications equipment; test and measurement equipment; audio and visual equipment; home electronic appliances; machine tools; personal electronic equipment; and industrial robots.
 - “High Quality”: Transportation equipment (automobiles, trains, ships, etc.); traffic control systems; anti-disaster systems; anti-crime systems; safety equipment; and medical equipment not specifically designed for life support.
 - “Specific”: Aircraft; aerospace equipment; submersible repeaters; nuclear reactor control systems; medical equipment or systems for life support (e.g. artificial life support devices or systems), surgical implantations, or healthcare intervention (e.g. excision, etc.), and any other applications or purposes that pose a direct threat to human life.
8. You should use the Renesas Electronics products described in this document within the range specified by Renesas Electronics, especially with respect to the maximum rating, operating supply voltage range, movement power voltage range, heat radiation characteristics, installation and other product characteristics. Renesas Electronics shall have no liability for malfunctions or damages arising out of the use of Renesas Electronics products beyond such specified ranges.
9. Although Renesas Electronics endeavors to improve the quality and reliability of its products, semiconductor products have specific characteristics such as the occurrence of failure at a certain rate and malfunctions under certain use conditions. Further, Renesas Electronics products are not subject to radiation resistance design. Please be sure to implement safety measures to guard them against the possibility of physical injury, and injury or damage caused by fire in the event of the failure of a Renesas Electronics product, such as safety design for hardware and software including but not limited to redundancy, fire control and malfunction prevention, appropriate treatment for aging degradation or any other appropriate measures. Because the evaluation of microcomputer software alone is very difficult, please evaluate the safety of the final products or system manufactured by you.
10. Please contact a Renesas Electronics sales office for details as to environmental matters such as the environmental compatibility of each Renesas Electronics product. Please use Renesas Electronics products in compliance with all applicable laws and regulations that regulate the inclusion or use of controlled substances, including without limitation, the EU RoHS Directive. Renesas Electronics assumes no liability for damages or losses occurring as a result of your noncompliance with applicable laws and regulations.
11. This document may not be reproduced or duplicated, in any form, in whole or in part, without prior written consent of Renesas Electronics.
12. Please contact a Renesas Electronics sales office if you have any questions regarding the information contained in this document or Renesas Electronics products, or if you have any other inquiries.

(Note 1) “Renesas Electronics” as used in this document means Renesas Electronics Corporation and also includes its majority-owned subsidiaries.

(Note 2) “Renesas Electronics product(s)” means any product developed or manufactured by or for Renesas Electronics.

M30220TF-PRB

User's Manual

Pod Probe for M30220 and M30221 Group MCUs

- NQPACK, YQPACK and YQ-GUIDE are products of Tokyo Eletech Corporation.

Keep safety first in your circuit designs!

- Renesas Technology Corporation and Renesas Solutions Corporation put the maximum effort into making semiconductor products better and more reliable, but there is always the possibility that trouble may occur with them. Trouble with semiconductors may lead to personal injury, fire or property damage. Remember to give due consideration to safety when making your circuit designs, with appropriate measures such as (i) placement of substitutive, auxiliary circuits, (ii) use of nonflammable material or (iii) prevention against any malfunction or mishap.

Notes regarding these materials

- These materials are intended as a reference to assist our customers in the selection of the Renesas Technology product best suited to the customer's application; they do not convey any license under any intellectual property rights, or any other rights, belonging to Renesas Technology Corporation, Renesas Solutions Corporation or a third party.
- Renesas Technology Corporation and Renesas Solutions Corporation assume no responsibility for any damage, or infringement of any third-party's rights, originating in the use of any product data, diagrams, charts, programs, algorithms, or circuit application examples contained in these materials.
- All information contained in these materials, including product data, diagrams, charts, programs and algorithms represents information on products at the time of publication of these materials, and are subject to change by Renesas Technology Corporation and Renesas Solutions Corporation without notice due to product improvements or other reasons. It is therefore recommended that customers contact Renesas Technology Corporation, Renesas Solutions Corporation or an authorized Renesas Technology product distributor for the latest product information before purchasing a product listed herein. The information described here may contain technical inaccuracies or typographical errors. Renesas Technology Corporation and Renesas Solutions Corporation assume no responsibility for any damage, liability, or other loss rising from these inaccuracies or errors. Please also pay attention to information published by Renesas Technology Corporation and Renesas Solutions Corporation by various means, including the Renesas home page (<http://www.renesas.com>).
- When using any or all of the information contained in these materials, including product data, diagrams, charts, programs, and algorithms, please be sure to evaluate all information as a total system before making a final decision on the applicability of the information and products. Renesas Technology Corporation and Renesas Solutions Corporation assume no responsibility for any damage, liability or other loss resulting from the information contained herein.
- Renesas Technology semiconductors are not designed or manufactured for use in a device or system that is used under circumstances in which human life is potentially at stake. Please contact Renesas Technology Corporation, Renesas Solutions Corporation or an authorized Renesas Technology product distributor when considering the use of a product contained herein for any specific purposes, such as apparatus or systems for transportation, vehicular, medical, aerospace, nuclear, or undersea repeater use.
- The prior written approval of Renesas Technology Corporation and Renesas Solutions Corporation is necessary to reprint or reproduce in whole or in part these materials.
- If these products or technologies are subject to the Japanese export control restrictions, they must be exported under a license from the Japanese government and cannot be imported into a country other than the approved destination. Any diversion or reexport contrary to the export control laws and regulations of Japan and/or the country of destination is prohibited.
- Please contact Renesas Technology Corporation or Renesas Solutions Corporation for further details on these materials or the products contained therein.

Precautions to be taken when using this product

- This product is a development supporting unit for use in your program development and evaluation stages. In mass-producing your program you have finished developing, be sure to make a judgment on your own risk that it can be put to practical use by performing integration test, evaluation, or some experiment else.
- In no event shall Renesas Solutions Corporation be liable for any consequence arising from the use of this product.
- Renesas Solutions Corporation strives to renovate or provide a workaround for product malfunction at some charge or without charge. However, this does not necessarily mean that Renesas Solutions Corporation guarantees the renovation or the provision under any circumstances.
- This product has been developed by assuming its use for program development and evaluation in laboratories. Therefore, it does not fall under the application of Electrical Appliance and Material Safety Law and protection against electromagnetic interference when used in Japan.
- This product is not qualified under UL or other safety standards and IEC or other industry standards. This fact must be taken into account when taking this product from Japan to some other country.

For inquiries about the contents of this document or product, fill in the text file the installer of the emulator debugger generates in the following directory and email to your local distributor.

\\SUPPORT\Product-name\SUPPORT.TXT

Renesas Tools Homepage <http://www.renesas.com/en/tools>

Preface

The M30220TF-PRB is a pod probe for flash memory rewrite mode debug of the M30220 and M30221 Group of Renesas 16-bit MCUs. The M30220TF-PRB is used by connecting to a PC4701 emulator main unit and the M30200T-RPD-E emulation pod main unit. This product can debug the CPU rewrite mode.

CPU rewrite mode debug is a function for debugging rewrites of internal flash memory using your application software. For details on specifications and writing conditions of CPU rewrite mode, refer to the user's manual of M30220 Group MCUs.

This manual mainly explains specifications, how to set up the M30220TF-PRB and the debugging procedure for CPU rewrite mode. For detail information about the emulator main unit, emulation pod main unit, and emulator debugger, refer to each user's manual.

Emulator main unit:	PC4701 User's Manual
Emulation pod main unit:	M30200T-RPD-E User's Manual
Emulator debugger:	M3T-PD30 User's Manual

To check the components of this product, refer to "2.1 Package Components" (page 14) in this manual. If there is any question or doubt about this product, contact your local distributor.

To use the product properly

Precautions for Safety:



- Both in this User's Manual and on the product itself, several icons are used to insure proper handling of this product and also to prevent injuries to you or other persons, or damage to your properties.
- The icons' graphic images and meanings are given in "Chapter 1. Precautions for Safety". Be sure to read this chapter before using the product.

Contents

Terminology	6
Chapter 1. Precautions for Safety	7
1.1 Safety Symbols and Meanings	8
Chapter 2. Preparation	13
2.1 Package Components	14
2.2 Other Tool Products Required for Development	14
2.3 System Configuration.....	15
Chapter 3. Setting Up	17
3.1 Switch Settings	18
3.2 A-D Conversion Bypass Capacitor	20
3.3 Connecting the M30200T-RPD-E.....	21
3.4 Connecting the Target System	22
3.5 Procedure for Making an MCU File for M3T-PD30	26
Chapter 4. Debugging Procedure for CPU Rewrite Mode	27
4.1 Outline of Debugging Procedure	28
4.2 Using Custom Commands dbg_reset and fmcrlset	29
(1) Custom Command dbg_reset	29
(2) Custom Command fmcrlset.....	30
4.3 Debugging Procedure	32
(1) Debugging Procedure for CPU Rewrite Mode (Microcomputer Mode) .	32
(2) Debugging Procedure for CPU Rewrite Mode (Boot Mode).....	34
4.4 How to Access Flash Memory Area	36
(1) Using Script Commands	36
(2) Using the Dump Window.....	36
(3) Using the RAM Monitor Window	36
4.5 Precautions for CPU Rewrite Mode	37
Chapter 5. Specifications	41
5.1 Specifications	42
5.2 External Dimensions	43
(1) External Dimensions of the Pod Probe	43
(2) External Dimensions of the Converter Board (FLX-144NSD).....	43
(3) External Dimensions of the Converter Board (FLX-144NSE)	44
(4) External Dimensions of the Converter Board (FLX-120NSE)	44

Chapter 6. Troubleshooting	45
6.1 When the Emulator Debugger Does Not Start Up Properly	46
(1) When the LED Display of PC4701 is Abnormal	46
(2) Errors Occur When Starting Up the Emulator Debugger (When the target system is connected).....	47
(3) Errors Occur When Starting Up the Emulator Debugger (When the target system is not connected)	48
6.2 Operation Differs from That of Actual MCUs	48
Chapter 7. Maintenance and Warranty	49
7.1 Maintenance	50
7.2 Warranty	50
7.3 Repair Provisions	50
7.4 How to Request for Repair	51

Terminology

Some specific words used in this user's manual are defined as follows:

Emulator system

This means an emulator system built around the PC4701 emulator. The PC4701 emulator system is configured with an emulator main unit, emulation pod, pod probe, host machine and emulator debugger.

Emulator main unit (Hereafter PC4701)

This means the generic name for emulators for 8 and 16-bit MCUs. For details on specific models of PC4701, visit Renesas Tools Homepage at <http://www.renesas.com/en/tools>

Emulation pod main unit

This means the emulation pod M30200T-RPD-E for the M16C/20 Series MCUs.

Pod probe

This means pod probe M30220TF-PRB (this product) for the M30220 and M30221 Groups.

Host machine

This means a personal computer used to control the emulator and emulation pod.

Emulator debugger

This means a software tool M3T-PD30 to control the emulator from the host machine through an interface.

Firmware

Program that analyzes contents of communication with the emulator debugger and controls the emulator hardware. This program is installed in the EEPROM in the emulator main unit. This program is downloadable from the emulator debugger to upgrade the firmware or to support other MCUs.

Software break

A software break is a function to break the program before the system executes an instruction at the specified address. The instruction at the preset address will not be executed.

Hardware break

A hardware break is a function to break the program when the system detects a write/read of data to/from memory or a rise/fall edge of the signal entered from the external trace cable. The former break function is called address break; and the latter break function is called trigger break. While the instruction at the address where the software break is set is not executed, a hardware break is performed after the specified instruction is executed.

Evaluation MCU

This means the MCU mounted on the pod probe which is operated in the specific mode for tools.

Target MCU

This means the MCU you are going to debug.

Target system

This means a user's application system using the MCU to be debugged.

*

In this user's manual, this symbol is used to show active LOW. (e.g. RESET*: Reset signal)

Chapter 1. Precautions for Safety

This chapter describes precautions for using this product safely and properly. For precautions for the emulator main unit, the emulation pod main unit and the emulator debugger, refer to each user's manual included with your product.



1.1 Safety Symbols and Meanings	8
IMPORTANT Note on Final Evaluation	9
Note on Differences between Actual MCU and Emulator	9
Note on Clock Supply to the MCU	10
Notes on Interrupts	10
Notes on DMA Transfer	10
Notes on NMI* Input	10
Notes on Referencing and Setting the Work Area	11
Notes on MAP References and Settings	11
Note on Reading SFR Area	11
Note on Instructions that Access the Single-step Interrupt Vector Area	11
Note on CPU Rewrite Mode	11

Chapter 1. Precautions for Safety

In both the user's manual and on the product itself, several icons are used to insure proper handling of this product and also to prevent injuries to you or other persons, or damage to your properties.

This chapter describes the precautions which should be taken in order to use this product safely and properly. Be sure to read this chapter before using this product.

1.1 Safety Symbols and Meanings

	WARNING	If the requirements shown in the "WARNING" sentences are ignored, the equipment may cause serious personal injury or death.
	CAUTION	If the requirements shown in the "CAUTION" sentences are ignored, the equipment may malfunction.
	IMPORTANT	It means important information on using this product.

In addition to the three above, the following are also used as appropriate.

△ means WARNING or CAUTION.
Example:  **CAUTION AGAINST AN ELECTRIC SHOCK**

⊘ means PROHIBITION.
Example:  **DISASSEMBLY PROHIBITED**

● means A FORCIBLE ACTION.
Example:  **UNPLUG THE POWER CABLE FROM THE RECEPTACLE.**

The following pages describe the symbol "IMPORTANT".

IMPORTANT

Note on Final Evaluation:

- Be sure to evaluate your system and make final confirmation with an CS (Commercial Sample) version MCU.

Note on Differences between Actual MCU and Emulator:

- Operations of the emulator system differ from those of actual MCUs as listed below.

(1) Initial values of internal resource data at power-on

(2) Internal memories (ROM and RAM) capacities, etc.

With this emulator system, "INT" (emulation memory ON) is the default for mapping areas other than the SFR area (addresses 000h - 3FFh). For this reason, the emulation memories can be read and written into in an area other than the SFR, internal RAM or internal ROM area.

(3) Oscillator circuit

- Make note of the fact that in the oscillator circuit where an oscillator is connected between the X_{IN} and X_{OUT} pins, oscillation does not occur because a flexible cable, buffer IC and other devices are used between the evaluation MCU and the target system. It is same for sub-clock oscillator circuits (X_{CIN} and X_{COU}T).
- For note on when using the oscillator circuit on the target system, refer to "4.2 (2) Using target system's oscillator" (page 21) of the M30200T-RPD-E User's Manual.

(4) X_{OUT} pin

The X_{OUT} pin is not assigned to the evaluation MCU used by this product. For this reason, the X_{OUT} pin of this product is open.

(5) DBC, single-step and BRK instruction interrupt vector table addresses

It is possible to download to DBC, single-step and BRK instruction interrupt vector table addresses. However, because the emulator system uses these areas, data different from the expected value is read out.

Table 1.1 Vector table addresses for the emulator

Factor to interrupt	Vector table addresses	Data for reading
DBC*1	FFFF4h - FFFF7h	Indefinite
Single-step*1	FFFECh - FFFEFh	Indefinite
BRK instruction*1	FFFE4h - FFFE7h	Indefinite

*1 Interrupts used for the debugger only

(6) A-D conversion

The characteristics of A-D converter differ from those of actual MCU because there are a flexible cable, pitch converter and other devices between the evaluation MCU and the target system. Make the final evaluation of the A-D converter with the actual MCU.

(7) D-A conversion

The characteristics of D-A converter differ from those of actual MCU because there are a flexible cable, pitch converter and other devices between the evaluation MCU and the target system. Make the final evaluation of the D-A converter with the actual MCU.

IMPORTANT

Note on Clock Supply to the MCU:

- Clock can be supplied to the evaluation MCU in one of the following two ways. This is determined by emulator debugger clock selection.
 - (1) When "Internal" is selected:
The clock generated by the oscillation circuit in the emulation pod is supplied to the evaluation MCU. The clock is continually supplied to the evaluation MCU regardless of "the state of target system clock" and "the state of target program execution".
 - (2) When "External" is selected:
Clock supply to the evaluation MCU depends on the state of oscillation (oscillate/off) of the target system.

Notes on Interrupts:

- Even while the target program is not being executed (i.e., even when the target program is paused or while debug programs are running), the evaluation MCU is operating for controlling debug programs. Therefore, take note that timers and other functions do not come to a halt when the target program is not executed.
- If a maskable interrupt is requested while a target program is not being executed (when the target program is paused or while debug programs are running), the interrupt is not accepted, because the emulator disables maskable interrupts. If a maskable interrupt is requested while a target program is not being executed and the program allow the interrupt, the interrupt is accepted immediately after the target program execution is started.

Notes on DMA Transfer:

- If a DMA request occurs by a timer or other source when the target program is not being executed (i.e., even when the target program is paused or while debug programs are running), DMA transfer is executed.
- Make note of the fact that DMA transfer while the target program is stopped may not be performed correctly.
- Note that the below registers are changed if DMA transfer is generated even when not executing the target program.

DMA0 transfer counter register:	TCR0
DMA1 transfer counter register:	TCR1
DMA0 control register:	DM0CON
DMA1 control register:	DM1CON

Notes on NMI* Input:

- NMI* input from the target system is accepted only while a target program is being executed (i.e., only while the RUN status LED on the PC4701's front panel is lit).
- The NMI* interrupt is generated in the following situations.
 - (1) Immediately after the NMI* pin changes from "H" to "L" level during target program execution
 - (2) Immediately after the reset from the target system is released with the NMI* pin "L" level during target program execution
 - (3) Immediately after program execution starts with the NMI* pin "L" level, following the reset is input from the debugger software or emulator
 - (4) Immediately after program execution starts with the NMI* pin "L" level, when the NMI* pin is "H" level immediately before the target program stops

IMPORTANT

Notes on Referencing and Setting the Work Area:

- When using this product, set a start address of the work area to "2C00h" at the time of starting up the emulator debugger (set by "F/W and Work Area" tab*1 of Init dialog). In this case, the emulator system uses the area below as a work area.

02C00h - 02C0Fh: Work area

*1 Supported by M3T-PD30 Ver.4.00 or later

- When using the custom command "fmcr1set" (see "4.2 (2) Custom Command fmcr1set" on page 30), the emulator system uses the area below as a work area for "fmcr1set".

02C10h - 02C1Ah: Work area for "fmcr1set"

Notes on MAP References and Settings:

- When starting up the M30200T-RPD-E, initial MAP settings are as follows. Use generally the M30200T-RPD-E in this setting.

00000h - 003FFh: "EXT"

00400h - FFFFFh: "INT" (emulation memory available)

- When debugging the control program for CPU rewrite mode, set the map setting for addresses E0000h to FFFDFh to "EXT" or "INT", as required. (See Chapter 4.) Be sure to set the map setting for addresses FFFE0h to FFFFFh to "INT".

Note on Reading SFR Area:

- The following registers cannot be read normally. However, they can be written to normally.

Pull-up control register 2

Key input mode register

Note on Instructions that Access the Single-step Interrupt Vector Area:

- Do not perform the below debugging operations with the single step interrupt vector area (addresses FFFECh - FFFEh).

(1) Step execution of instructions that access the single step interrupt vector area

(2) Program execution from the instruction accessing the single step interrupt vector area when a software breakpoint is set at the instruction

Note on CPU Rewrite Mode:

- For the notes for debugging the control program for CPU rewrite mode, refer to "4.5 Precautions for CPU Rewrite Mode" (page 37).

MEMO

Chapter 2. Preparation

This chapter describes the package components, the system configuration and the preparation for using this product for the first time.

2.1 Package Components	14
2.2 Other Tool Products Required for Development	14
2.3 System Configuration	15

Chapter 2. Preparation

2.1 Package Components

This product consists of the following items. When unpacking, check to see if your product package contains all of these items.

Table 2.1 Package components

Item	Quantity
M30220TF-PRB pod probe for flash memory rewrite mode debug of M30220 and M30221 Group MCUs	1
Screws for fixing pod probe	2
Floppy disk (custom program file)	1
M30220TF-PRB User's Manual (this manual)	1
M30220TF-PRB User's Manual (Japanese)	1
M30220TF-PRB Repair Request Sheet (English/Japanese)	1

Please keep the M30220TF-PRB's packing box and cushion material in your place for reuse at a later time when sending your product for repair or other purposes. Always use these packing box and cushion material when transporting the M30220TF-PRB.

If any of these items are missing or found faulty, please contact your local distributor. Also, if there is any question or doubt about the packaged product, contact your local distributor.

2.2 Other Tool Products Required for Development

To bring forward programs development on the M30220 and M30221 Group MCUs, the products listed below are necessary in addition to the package components listed above. Get them separately.

Table 2.2 Other tool products

Emulator main unit	PC4701
Emulation pod main unit	M30200T-RPD-E
Emulator debugger	M3T-PD30 Ver.4.00 or later
Converter board	For 144-pin LQFP (144P6Q-A): FLX-144NSD For 144-pin TQFP (144PFB-A): FLX-144NSE For 120-pin LQFP (120P6R-A): FLX-120NSE The converter board which matches to the foot pattern of the target system is required.

To purchase these products, contact your nearest distributor.

2.3 System Configuration

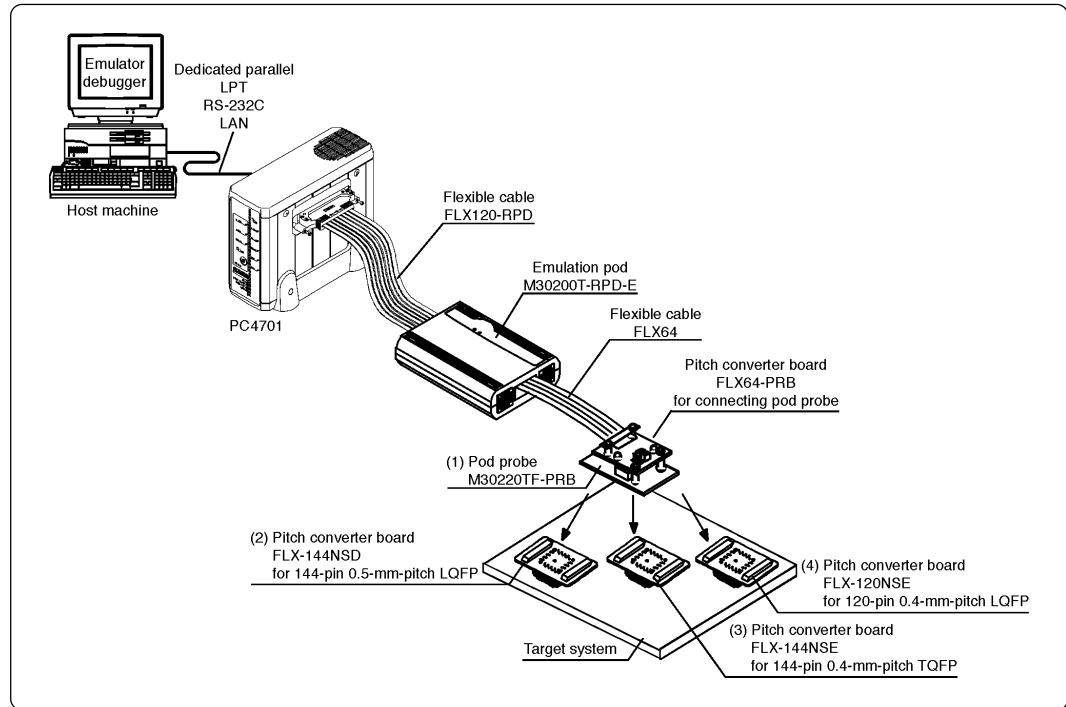

Figure 2.1 System configuration

Product (1) shown in Figure 2.1 is this product. Get (2) to (4) separately.

(1) Pod probe (M30220TF-PRB)

This pod probe is for flash memory rewrite mode debug of M30220 and M30221 Group MCUs. The evaluation MCUs M30220GP-EVA and M30220GP-PORT are mounted on it.

(2) Pitch converter board for 144-pin 0.5-mm-pitch LQFP (FLX-144NSD)

This is a pitch converter board (separately available) to be mounted on the foot pattern for 144-pin 0.5-mm-pitch LQFP prepared on the target system.

(3) Pitch converter board for 144-pin 0.4-mm-pitch TQFP (FLX-144NSE)

This is a pitch converter board (separately available) to be mounted on the foot pattern for 144-pin 0.4-mm-pitch TQFP prepared on the target system.

(4) Pitch converter board for 120-pin 0.4-mm-pitch LQFP (FLX-120NSE)

This is a pitch converter board (separately available) to be mounted on the foot pattern for 120-pin 0.4-mm-pitch LQFP prepared on the target system.

For details on the connection, refer to "3.4 Connecting the Target System" (page 22).

MEMO

Chapter 3. Setting Up

This chapter describes switch settings required for using this product and how to connect this product to the PC4701 and the target system.

3.1 Switch Settings	18
3.2 A-D Conversion Bypass Capacitor	20
3.3 Connecting the M30200T-RPD-E	21
3.4 Connecting the Target System.....	22
3.5 Procedure for Making an MCU File for M3T-PD30.....	26

Chapter 3. Setting Up

With this product, it is necessary to set the following according to your target system.

- CNVSS pin to the target system
- XCIN/XCOUT pin to the target system
- Mounting the A-D conversion bypass capacitor

3.1 Switch Settings

It is necessary to set the switches of the M30220TF-PRB and FLX64-PRB for debugging according to the target system. Figure 3.1 shows the positions of the switches of the M30220TF-PRB and FLX64-PRB, and Table 3.1 shows the switch settings.

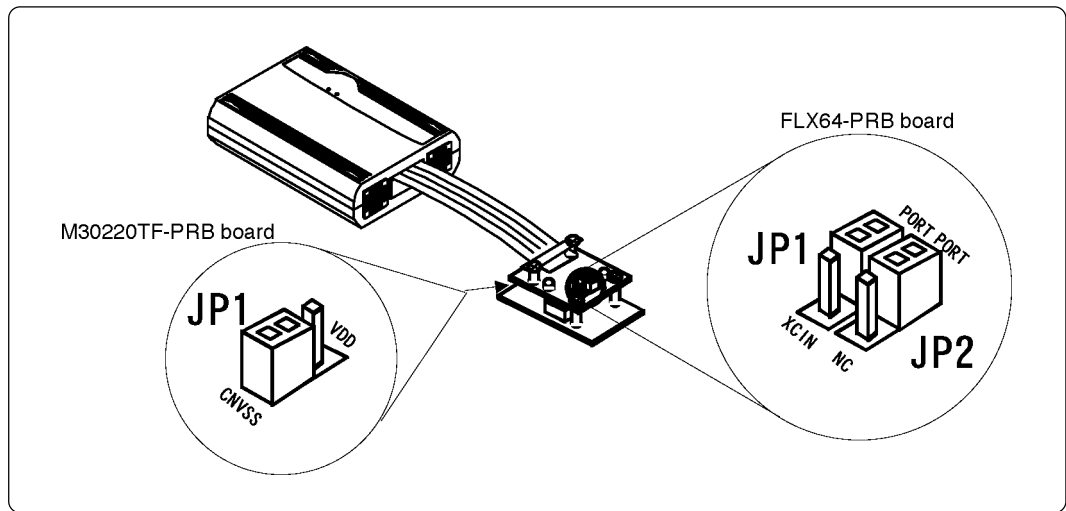





Figure 3.1 Positions of the switches and their factory-settings

Table 3.1 Switch settings of the M30220TF-PRB and FLX64-PRB

Board	Switch No.	Function	Switch setting	
M30220TF-PRB	JP1	CNVSS	 <p>When connecting CNVSS to the target system (Factory-setting)</p>	 <p>Applies the VCC voltage to CNVSS. When not connecting the target, applies 5 V.</p>
FLX64-PRB	JP1	X _{CIN}	The M30220TF-PRB does not use this switch. X _{CIN} is always selected in any setting.	
	JP2	X _{COUT}	 <p>When connecting X_{COUT} to the target system (Factory-setting)</p>	 <p>When not connecting X_{COUT} to the target system</p>

IMPORTANT

Note on CNVSS:

- To debug the control program for CPU rewrite mode, you need to apply 4.5 to 5.5 V voltage to the CNVSS pin.

When the target system is connected:

Set the jumper switch JP1 of the M30220TF-PRB to "CNVSS". The CNVSS is connected to the target system. Apply 4.5V to 5.5V voltage to the CNVSS pin of the target system.

When the target system is NOT connected:

Set the jumper switch JP1 of the M30220TF-PRB to "VDD". 5V voltage is applied from the emulation pod to the CNVSS.

3.2 A-D Conversion Bypass Capacitor

This product has foot patterns on the board for mounting a bypass capacitor for the A-D converter circuit. Mount a suitable bypass capacitor as occasion demands.

Figure 3.2 shows the position of the bypass capacitor.

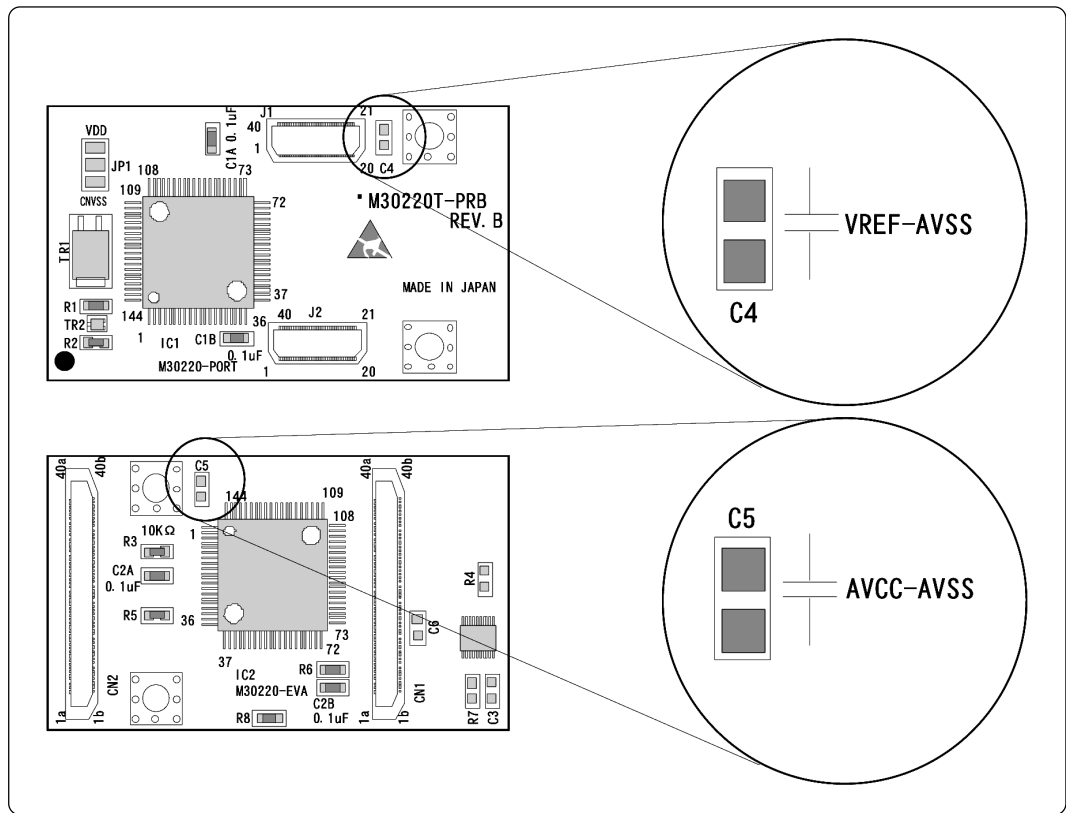

Figure 3.2 Foot patterns of A-D conversion bypass capacitor

IMPORTANT

Note on the Operation of A-D Converter:

- The characteristics of A-D converter differ from those of actual MCU because there are a flexible cable, pitch converter and other devices between the evaluation MCU and the target system. Make the final evaluation of the A-D converter with the actual MCU.

3.3 Connecting the M30200T-RPD-E

The emulation pod for flash memory rewrite mode debug of the M30220 and M30221 Group MCUs consists of the two products, the M30200T-RPD-E emulation pod main unit and the M30220TF-PRB pod probe. Figures 3.3 and 3.4 show how to connect the M30220TF-PRB and how to remove it, respectively.

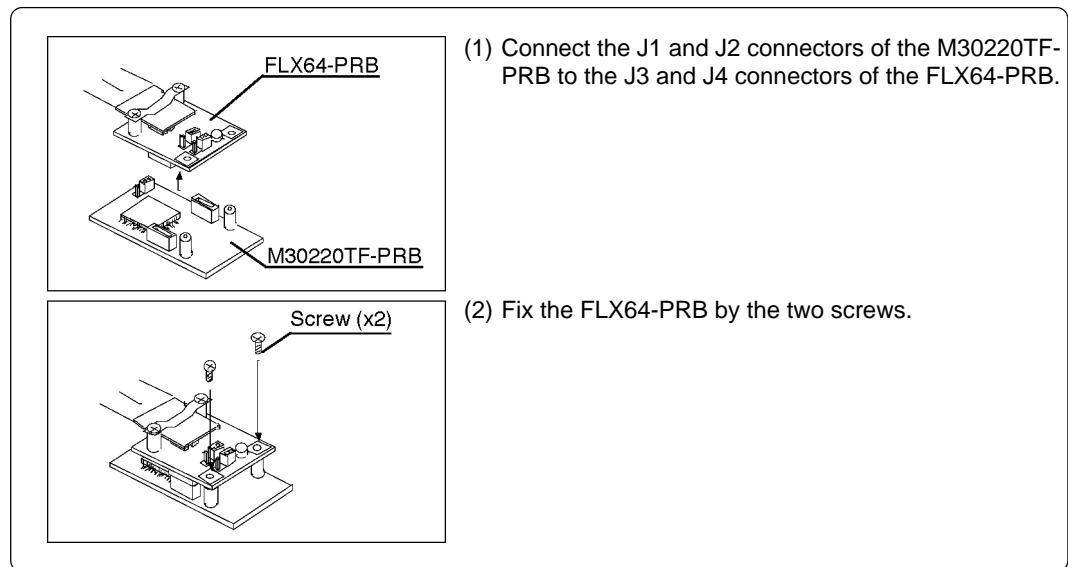

Figure 3.3 Connecting pod probe M30220TF-PRB

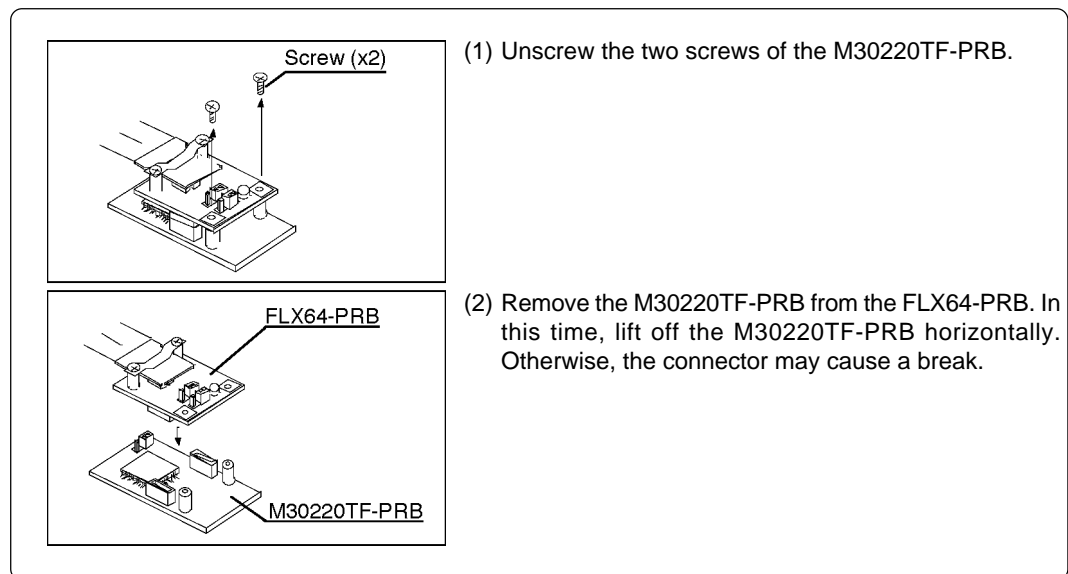

Figure 3.4 Removing pod probe M30220TF-PRB

CAUTION

When Connecting Pod Probe:

- Be sure to turn off the power before making connections. Otherwise, the internal circuits may be damaged.
- The small connectors of the M30220TF-PRB (J3 and J4) are guaranteed for only 50 insertion/removal iterations.
- The small connectors of the FLX64-PRB (J3 and J4) and M30220TF-PRB (J1 and J2) are guaranteed for only 50 insertion/removal iterations.

3.4 Connecting the Target System

There are three ways available to connect this product to target system as shown in Figure 3.5.

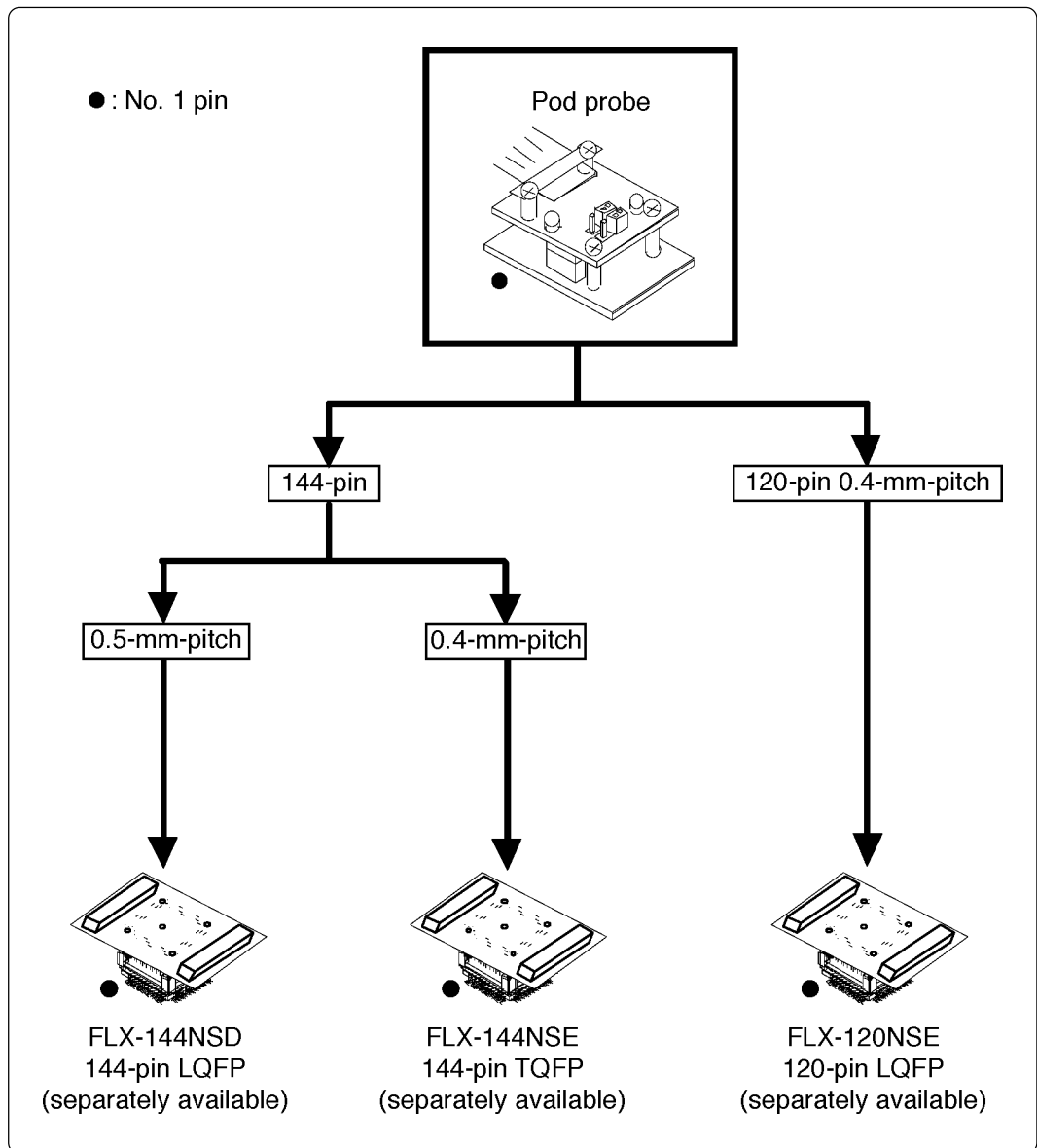

Figure 3.5 Connecting the target system

Figures 3.6, 3.7 and 3.8 show how to connect the pitch converter board FLX-144NSD for 144-pin 0.5-mm-pitch package, how to connect the pitch converter board FLX-144NSE for 144-pin 0.4-mm-pitch package and how to connect the pitch converter board FLX-120NSE for 120-pin 0.4-mm-pitch package, respectively.

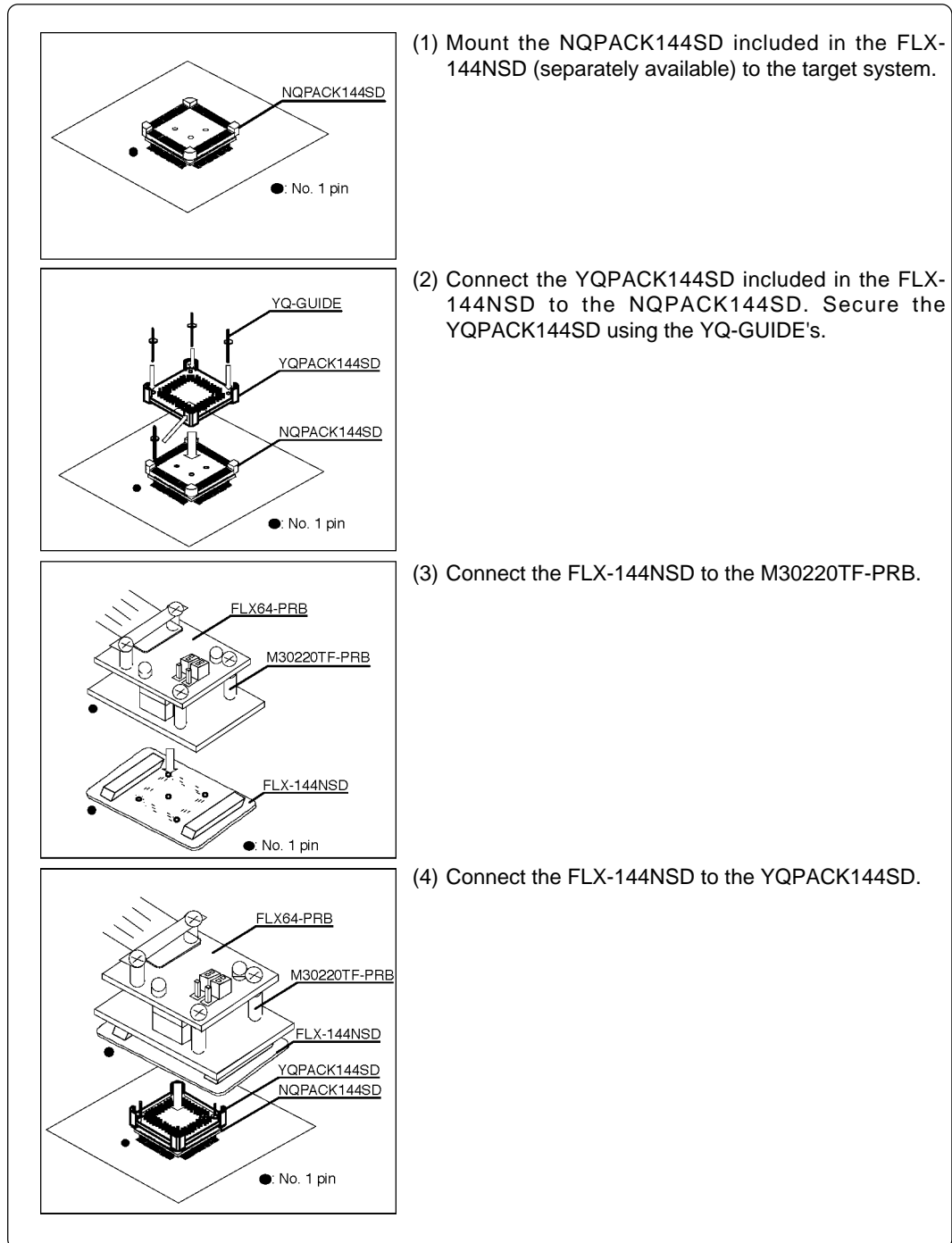

Figure 3.6 Connecting the pitch converter board FLX-144NSD for 144-pin 0.5-mm-pitch LQFP

⚠ CAUTION

Note on Connecting the Target System:

- Take care not to mount the pitch converter board in a wrong direction.

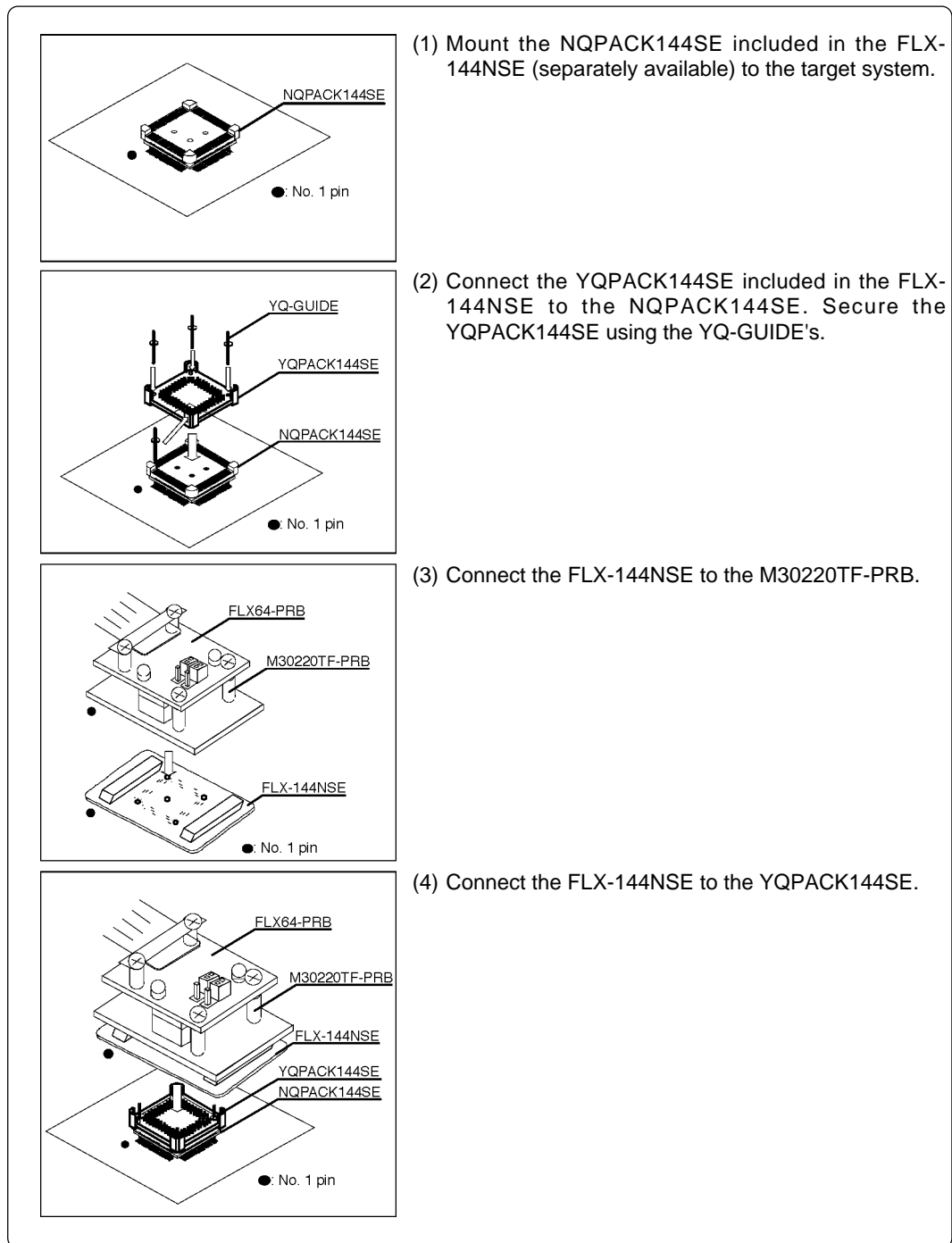

Figure 3.7 Connecting the pitch converter board FLX-144NSE for 144-pin 0.4-mm-pitch TQFP

CAUTION

Note on Connecting the Target System:

- Take care not to mount the pitch converter board in a wrong direction.

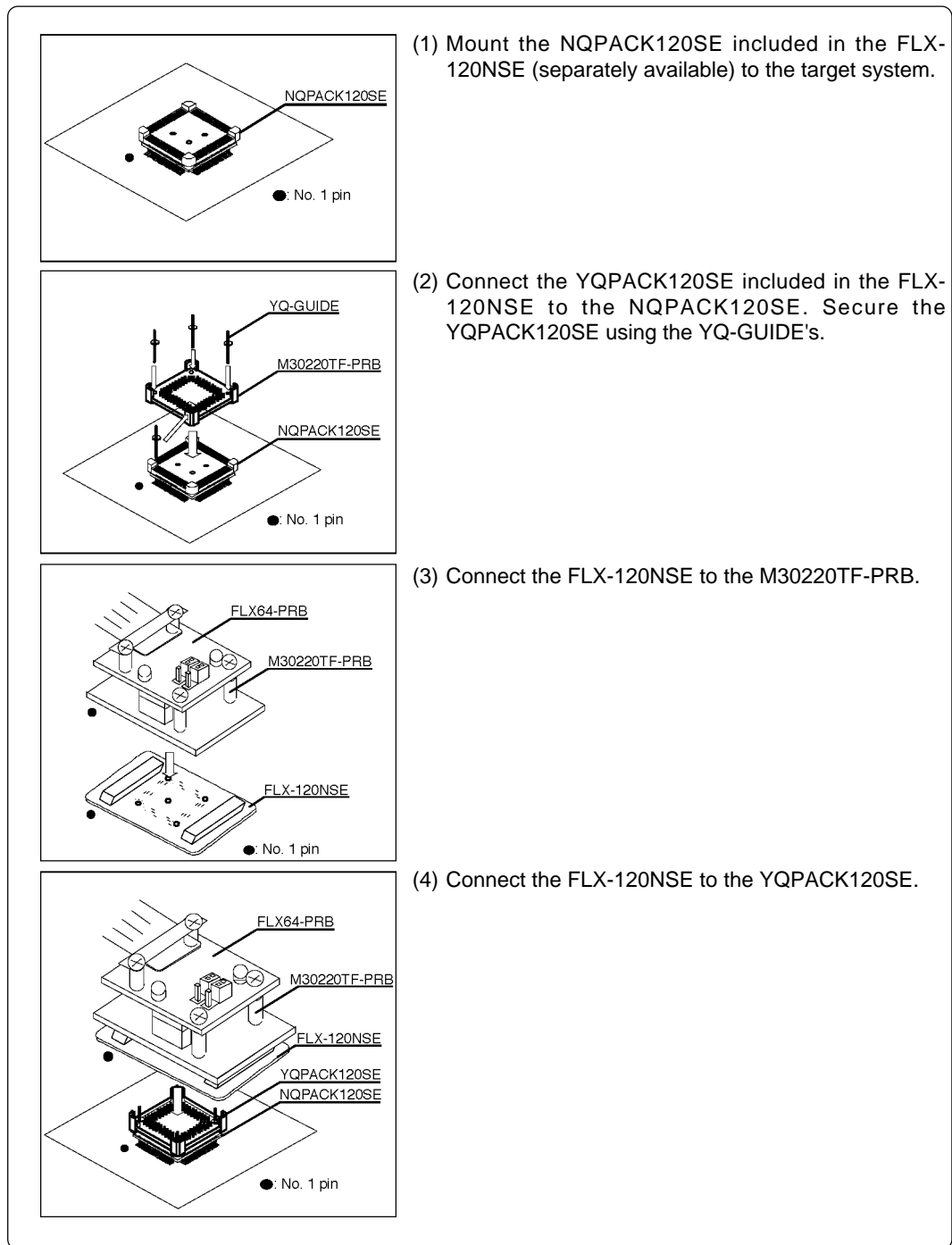

Figure 3.8 Connecting the pitch converter board FLX-120NSE for 120-pin 0.4-mm-pitch LQFP

CAUTION

Note on Connecting the Target System:

- Take care not to mount the pitch converter board in a wrong direction.

3.5 Procedure for Making an MCU File for M3T-PD30

It is necessary to change the contents of the MCU file according to the MCU to be developed. Make the MCU file M30220.MCU for M30220 Group and M30221.MCU for M30221 Group and store it in the "mcufiles" folder in the folder where emulator debugger M3T-PD30 is stored. For M3T-PD30 Ver.4.10 or earlier, store the MCU file in the same folder as emulator debugger M3T-PD30 is stored in.

The contents of the MCU file give the addresses of SFR area, internal RAM area, internal ROM area and the name of firmware file. Change the contents of the MCU file according to the MCU to be debugged. Use your editor for changing the MCU file.

The examples of contents of the MCU file are as follows:

(1) For 30220 Group, 10KB RAM, 128KB ROM (file name: M30220.MCU)

0	:	SFR area	Start address
3FF	:		End address
400	:	Internal RAM	Start address
2BFF	:		End address
E0000	:	Internal ROM	Start address
FFFFFF	:		End address
M30620B	:	Name of firmware (Do not change.)	
0	:	Expansion No.	M3T-PD30 V.4.00 or later required (Do not change.)

(2) For 30221 Group, 1.5KB RAM, 24KB ROM (file name: M30221.MCU)

0	:	SFR area	Start address
3FF	:		End address
400	:	Internal RAM	Start address
9FF	:		End address
FA000	:	Internal ROM	Start address
FFFFFF	:		End address
M30620B	:	Name of firmware (Do not change.)	
0	:	Expansion No.	M3T-PD30 V.4.00 or later required (Do not change.)

Chapter 4. Debugging Procedure for CPU Rewrite Mode

This chapter describes procedure for debugging the control program for CPU rewrite mode and restrictions.

4.1 Outline of Debugging Procedure	28
4.2 Using Custom Commands dbg_reset and fmcrlset	29
(1) Custom Command dbg_reset	29
(2) Custom Command fmcrlset	30
4.3 Debugging Procedure	32
(1) Debugging Procedure for CPU Rewrite Mode (Microcomputer Mode)	32
(2) Debugging Procedure for CPU Rewrite Mode (Boot Mode)	34
4.4 How to Access Flash Memory Area	36
(1) Using Script Commands	36
(2) Using the Dump Window	36
(3) Using the RAM Monitor Window	36
4.5 Precautions for CPU Rewrite Mode	37
Note on Custom Command dbg_reset	37
Note on CNVSS	37
Note on Address E0000h - FFFDFh Memory	37
Note on Boot Mode	37
Notes on Setting Software Breaks	38
Note on RESET from the Target System	38
Note on Setting the CPU Rewrite Mode Select Bit	38
Note on Address FFFE0h - FFFFFh	38
Note on Changing the Mode of Flash Memory	38
Note on Step Execution	38
Note on Number of Program/Erase	39
Note on Shutting OFF the Power	39

Chapter 4. Debugging Procedure for CPU Rewrite Mode

4.1 Outline of Debugging Procedure

You can use the flash memory in the evaluation MCU on the M30220TF-PRB to debug the control program for CPU rewrite mode. Figure 4.1 shows a flow chart of the process.

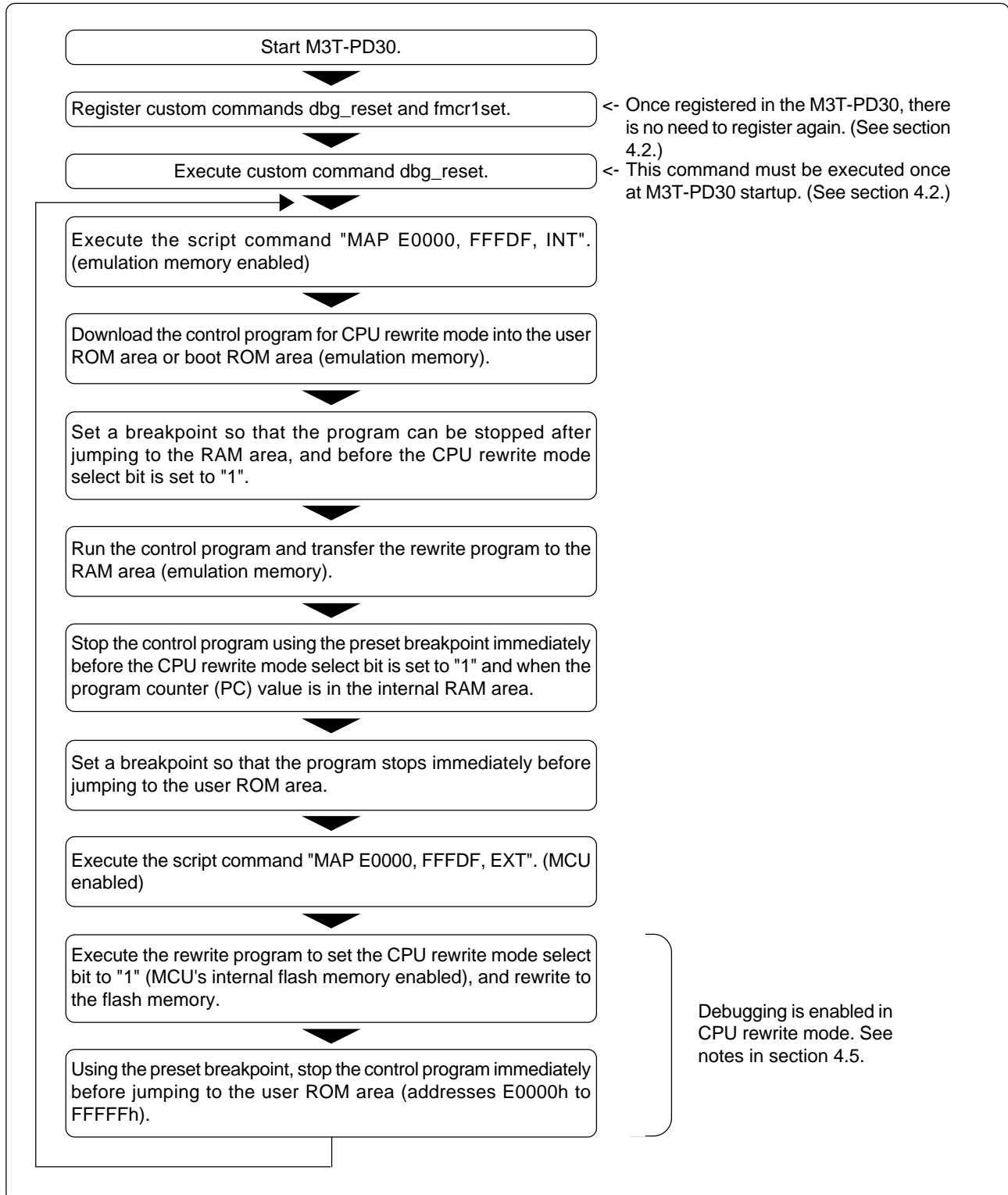

Figure 4.1 Flowchart of CPU Rewrite Mode Control Program Debugging

The process shown in this flowchart is not required for normal program debugging.

4.2 Using Custom Commands `dbg_reset` and `fmcr1set`

The custom commands `dbg_reset` and `fmcr1set` must be used when debugging in CPU rewrite mode. The custom command program file is provided on the attached floppy disk.

(1) Custom Command `dbg_reset`

When debugging in CPU rewrite mode, you must execute custom command `dbg_reset` to initialize tool control.

To use custom command `dbg_reset`, use the following procedure to register `dbg_reset` in the M3T-PD30. Once registered, `dbg_reset` can be used without the need to reregister it each time.

How to register `dbg_reset` with M3T-PD30

Step 1: Copy file.

Copy `dbg_reset.p` (program file of custom command `dbg_reset`) from the attached floppy disk to the host machine.

Example 1:

Copy `dbg_reset.p` to the folder (e.g. `C:\¥MTOOL¥M3T-PD30`) containing the executable file of M3T-PD30 (`M3T-PD30.exe`).

Step 2: Set the search path of the custom program.

Open the M3T-PD30 script window and execute the following script command:

```
MacroPATH "absolute directory to which dbg_reset.p was copied"
```

Example 1:

```
MacroPATH C:\¥MTOOL¥M3T-PD30 <RET>
```

The `MacroPATH` command is the script command to set the path specified in the argument as the path to the custom program in M3T-PD30.

Step 3: Register custom command `dbg_reset`.

Execute the following script command in the M3T-PD30 script window:

```
MACRO dbg_reset <RET>
```

The `MACRO` command is the script command to register the custom command specified in the argument in M3T-PD30. This completes registration of custom command `dbg_reset` in M3T-PD30. Custom command `dbg_reset` can now be executed from the script window command input area in the same way as script commands. See the specifications for the custom command (shown below) for the input format, etc. Note that once the custom command has been registered, the registration remains valid until deleted using the `DELMACRO` or `DELMACROALL` script command.

Step 4: Restart M3T-PD30.

After completing steps 1 to 3, restart M3T-PD30. To use the custom command `dbg_reset`, make sure that the search path is the absolute directory to which `dbg_reset.p` was copied.

Custom command `dbg_reset` specifications

Input format: `dbg_reset`

Function: Initializes and resets tool control for debugging in CPU rewrite mode.

(Note)

- This command cannot be used while the target program is running.

Command execution example

Example 1: `dbg_reset` must be executed after starting M3T-PD30 if you are debugging in CPU rewrite mode.

```
> dbg_reset <RET>
DBG_RESET is done !!
>
```

(2) Custom Command `fmcr1set`

When setting "1" in the CPU rewrite mode select bit (FMCR1) (bit 1 of the flash memory control register (address 3B4h), you must write "0" followed consecutively by "1". Because of the interval between the execution of two normal script commands, it is not possible using these normal script commands to write "0" followed consecutively by "1". You can set "1" by using the custom command `fmcr1set`, which consecutively writes "0", "1" to the CPU rewrite mode select bit (FMCR1).

To use custom command `fmcr1set`, use the following procedure to register `fmcr1set` in the M3T-PD30. Once registered, `fmcr1set` can be used without the need to reregister it each time.

How to register `fmcr1set` with M3T-PD30

Step 1: Copy file.

Copy `fmcr1set.p` (program file of custom command `fmcr1set`) from the attached floppy disk to the host machine.

Example 1:

Copy `fmcr1set.p` to the directory (e.g. `C:\MTOOL\M3T-PD30`) containing the executable file of M3T-PD30 (`M3T-PD30.exe`).

Step 2: Set the search path of the custom program.

Open the M3T-PD30 script window and execute the following script command:

```
MacroPATH "absolute directory to which fmcr1set.p was copied"
```

Example 1:

```
MacroPATH C:\MTOOL\M3T-PD30 <RET>
```

The `MacroPATH` command is the script command to set the path specified in the argument as the path to the custom program in M3T-PD30.

Step 3: Register custom command `fmcr1set`.

Execute the following script command in the M3T-PD30 script window:

```
MACRO fmcr1set <RET>
```

The `MACRO` command is the script command to register the custom command specified in the argument in M3T-PD30. This completes registration of custom command `fmcr1set` in M3T-PD30. Custom command `fmcr1set` can now be executed from the script window command input area in the same way as script commands. See the specifications for the custom command (shown below) for the input format, etc. Note that once the custom command has been registered, the registration remains valid until deleted using the `DELMACRO` or `DELMACROALL` script command.

Step 4: Restart M3T-PD30.

After completing steps 1 to 3, restart M3T-PD30. To use the custom command `fmcr1set`, make sure that the search path is the absolute directory to which `fmcr1set.p` was copied.

Custom command fmcrlset specifications

Input format: fmcrlset

Function: fmcrlset writes the instruction to write "0" and the instruction to write "1" to the CPU rewrite mode select bit (FMCR1) at addresses 2C10h to 2C1Ah, executes them, then sets back the program counter (PC). The program window display starts at the address set in the program counter (PC).

(Notes)

- The fmcrlset command can set "1" in the CPU rewrite mode select bit (FMCR1).
- This command cannot be used while the target program is running.
- When the PC is where there is no source file, the program window is displayed in Dis Assemble Mode and the PC line may be displayed in black. If displayed in black, it indicates that the line is selected. Select another line so that the PC line is displayed in yellow.

Command execution example

Example 1: To set "1" in the CPU rewrite mode select bit (FMCR1).

```
> fmcrlset <RET>
```

```
FMCR1SET is done !!
```

```
>
```

4.3 Debugging Procedure

(1) Debugging Procedure for CPU Rewrite Mode (Microcomputer Mode)

Here following describe the debugging procedure in microcomputer mode. Figure 4.2 shows the memory map when debugging.

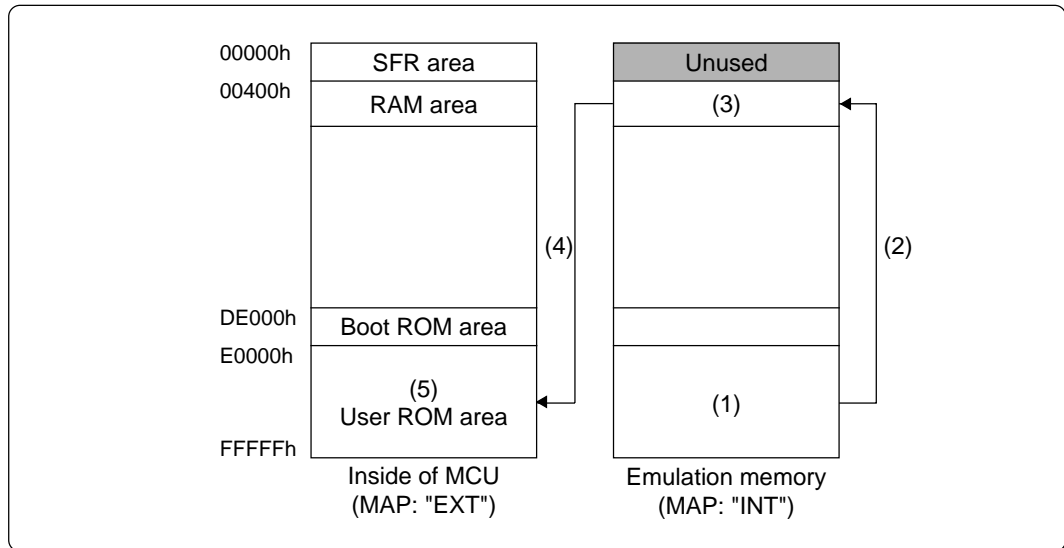

Figure 4.2 Memory map when debugging in microcomputer mode

Procedure	Description								
(1)	<p>Downloading the control program for CPU rewrite mode</p> <ul style="list-style-type: none"> You must execute custom command <code>dbg_reset</code> before debugging the control program for CPU rewrite mode. Set the MAP for addresses E0000h to FFFDFh to "INT" (to enable emulation memory). Download the control program for CPU rewrite mode to be debugged to emulation memory. After downloading the control program, set a breakpoint as indicated below. (See the next page, Table 4.1 for an example.) "Stop after jumping to the RAM area, and before setting the CPU rewrite mode select bit to "1"." 								
(2)	<p>Transfer the control program for CPU rewrite mode to the RAM area.</p> <ul style="list-style-type: none"> Running the program transfers the control program for CPU rewrite mode to the RAM area (emulation memory). 								
(3)	<p>Set the map for user ROM area E0000h to FFFDFh to "EXT".</p> <ul style="list-style-type: none"> Using the breakpoint set in (1), stop program execution after jumping to RAM area, and before the CPU rewrite mode select bit is set to "1". Set the MAP for addresses E0000h to FFFDFh to "EXT" (to enable the evaluation MCU). Set a breakpoint as indicated below. (See the next page, Table 4.1 for an example.) "Stop immediately before jumping to user ROM area." 								
(4)	<p>Write to flash memory.</p> <ul style="list-style-type: none"> Flash memory is rewritten to by running the control program. See "4.5 Precautions for CPU Rewrite Mode" (page 37) for notes. Using the breakpoint set in step (3), stop at the end of the control program for CPU rewrite mode. 								
(5)	<p>Check the contents of MCU's internal flash memory after rewriting.</p> <ul style="list-style-type: none"> In step (4), by changing the settings as shown below, you can read the contents of the MCU's internal flash memory using the script command, dump window and RAM monitor window. For details on how to access, refer to Section 4.4 (page 36) and the precautions to Section 4.5 (page 37). <table border="1" style="margin-left: 40px;"> <thead> <tr> <th>Item</th> <th>Setting</th> </tr> </thead> <tbody> <tr> <td>Map of addresses E0000h - FFFDFh</td> <td>EXT</td> </tr> <tr> <td>CPU rewrite mode select bit (FMCR1)</td> <td>1</td> </tr> <tr> <td>Mode of flash memory</td> <td>Read array mode</td> </tr> </tbody> </table>	Item	Setting	Map of addresses E0000h - FFFDFh	EXT	CPU rewrite mode select bit (FMCR1)	1	Mode of flash memory	Read array mode
Item	Setting								
Map of addresses E0000h - FFFDFh	EXT								
CPU rewrite mode select bit (FMCR1)	1								
Mode of flash memory	Read array mode								

Table 4.1 lists how to set breakpoints for procedures 1 and 3.

Table 4.1 How to set breakpoints for procedures 1 and 3

Procedure	Description
1	<ul style="list-style-type: none"> Examples 1 and 2 show how to set breakpoints to have the result shown below. "Stop after jumping to the RAM area, and before setting the CPU rewrite mode select bit to "1"." <p>Example 1: Set a software break at the instruction to jump to the RAM area. After stopping, set the program window to disassemble display mode and step execute the jump to the RAM area. This allows you to stop in the RAM area.</p> <p>Example 2: If there are 10 or more cycles after jumping to the RAM area and before the instruction to access the CPU rewrite mode select bit, set a hardware break to the RAM area Fetch.</p>
3	<ul style="list-style-type: none"> Examples 1, 2, and 3 show how to set breakpoints to have the result shown below: "Stop immediately before jumping to user ROM area." <p>Example 1: A jump to the user ROM area is made at the end of the control program written to RAM. Set a software break at the jump instruction.</p> <p>Example 2: Set a software break in the instruction to set "0" in the CPU rewrite mode select bit.</p> <p>Example 3: If there are enough cycles between the instruction to set "0" in the CPU rewrite mode select bit and the instruction to jump to the user ROM area, set a hardware break to the Write access to the flash memory control register (address 3B4h).</p>

CAUTION

Note on Address E0000h - FFFDFh Memory:

- When both the MAP setting for addresses E0000h to FFFDFh is "INT" and the FMCR1 is set to "1", both the emulation memory and the MCU's internal flash memory are enabled and bus collisions occur. Please avoid combining these settings.

Table 4.2 Address E0000h - FFFDFh memory

Map setting	FMCR1 setting	Remarks
INT	1	Do not set in this way.

(2) Debugging Procedure for CPU Rewrite Mode (Boot Mode)

Here following describe the debugging procedure in boot mode. Figure 4.3 shows the memory map when debugging.

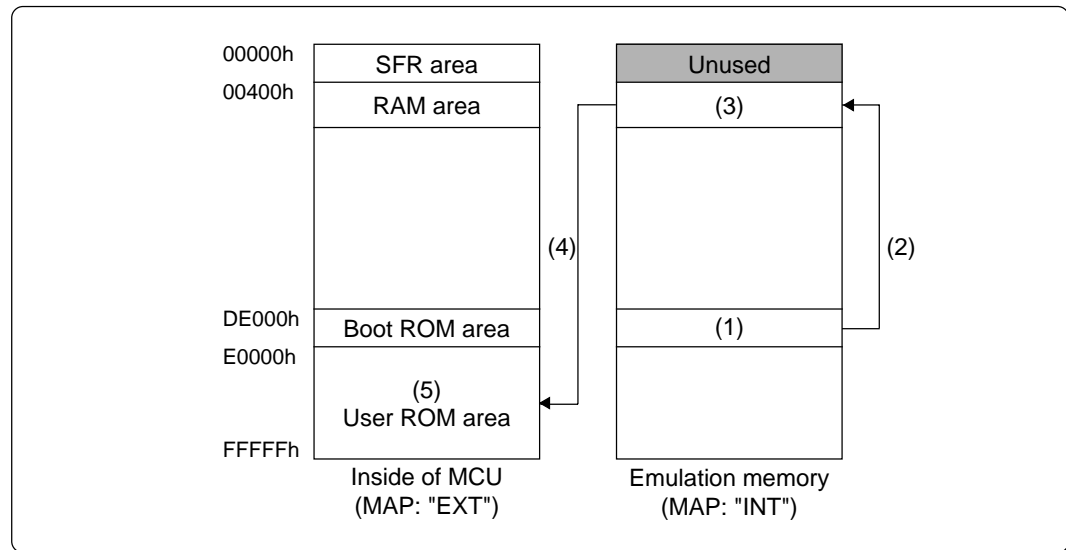

Figure 4.3 Memory map when debugging in boot mode

Procedure	Description								
(1)	<p>Downloading the control program for CPU rewrite mode</p> <ul style="list-style-type: none"> You must execute custom command <code>dbg_reset</code> before debugging the control program for CPU rewrite mode. Download the control program for CPU rewrite mode into emulation memory. Also, download the value of the reset vector, DE000h. When you do not download the value of the reset vector, write "DE000h" in the reset vector area using Fill command. After downloading the control program, set a breakpoint as indicated below. (See the next page, Table 4.3 for an example.) "Stop after jumping to the RAM area, and before setting the CPU rewrite mode select bit to "1"." 								
(2)	<p>Transfer the control program for CPU rewrite mode to the RAM area.</p> <ul style="list-style-type: none"> Running the program transfers the control program for CPU rewrite mode to the RAM area (emulation memory). 								
(3)	<p>Set the map for user ROM area E0000h to FFFDFh to "EXT".</p> <ul style="list-style-type: none"> Using the breakpoint set in (1), stop program execution after jumping to RAM area, and before the CPU rewrite mode select bit is set to "1". Set the MAP for addresses E0000h to FFFDFh to "EXT" (to enable the evaluation MCU). Set a breakpoint as indicated below. (See the next page, Table 4.3 for an example.) "Stop immediately before jumping to user ROM area." 								
(4)	<p>Write to flash memory.</p> <ul style="list-style-type: none"> Flash memory is rewritten to by running the control program. See "4.5 Precautions for CPU Rewrite Mode" (page 37) for notes. Using the breakpoint set in step (3), stop at the end of the control program for CPU rewrite mode. Set the program window to disassemble display mode (DIS) and execute the instruction that jumps to the user ROM area in step mode. 								
(5)	<p>Check the contents of MCU's internal flash memory after rewriting.</p> <ul style="list-style-type: none"> In step (4), by changing the settings as shown below, you can read the contents of the MCU's internal flash memory using the script command, dump window and RAM monitor window. For details on how to access, refer to Section 4.4 (page 36) and the precautions to Section 4.5 (page 37). <table border="1" style="margin-left: 40px;"> <thead> <tr> <th>Item</th> <th>Setting</th> </tr> </thead> <tbody> <tr> <td>Map of addresses E0000h - FFFDFh</td> <td>EXT</td> </tr> <tr> <td>CPU rewrite mode select bit (FMCR1)</td> <td>1</td> </tr> <tr> <td>Mode of flash memory</td> <td>Read array mode</td> </tr> </tbody> </table>	Item	Setting	Map of addresses E0000h - FFFDFh	EXT	CPU rewrite mode select bit (FMCR1)	1	Mode of flash memory	Read array mode
Item	Setting								
Map of addresses E0000h - FFFDFh	EXT								
CPU rewrite mode select bit (FMCR1)	1								
Mode of flash memory	Read array mode								

Table 4.3 lists how to set breakpoints for procedures 1 and 3.

Table 4.3 How to set breakpoints for procedures 1 and 3

Procedure	Description
1	<ul style="list-style-type: none"> Examples 1 and 2 show how to set breakpoints to have the result shown below. "Stop after jumping to the RAM area, and before setting the CPU rewrite mode select bit to "1"." <p>Example 1: Set a software break at the instruction to jump to the RAM area. After stopping, set the program window to disassemble display mode and step execute the jump to the RAM area. This allows you to stop in the RAM area.</p> <p>Example 2: If there are 10 or more cycles after jumping to the RAM area and before the instruction to access the CPU rewrite mode select bit, set a hardware break to the RAM area Fetch.</p>
3	<ul style="list-style-type: none"> Examples 1, 2, and 3 show how to set breakpoints to have the result shown below: "Stop immediately before jumping to user ROM area." <p>Example 1: A jump to the user ROM area is made at the end of the control program written to RAM. Set a software break at the jump instruction.</p> <p>Example 2: Set a software break in the instruction to set "0" in the CPU rewrite mode select bit.</p> <p>Example 3: If there are enough cycles between the instruction to set "0" in the CPU rewrite mode select bit and the instruction to jump to the user ROM area, set a hardware break to the Write access to the flash memory control register (address 3B4h).</p>

CAUTION

Note on Address E0000h - FFFDFh Memory:

- When both the MAP setting for addresses E0000h to FFFDFh is "INT" and the FMCR1 is set to "1", both the emulation memory and the MCU's internal flash memory are enabled and bus collisions occur. Please avoid combining these settings.

Table 4.4 Address E0000h - FFFDFh memory

Map setting	FMCR1 setting	Remarks
INT	1	Do not set in this way.

4.4 How to Access Flash Memory Area

When flash memory is enabled (MAP setting for addresses E0000h to FFFDFh is "EXT" and CPU rewrite mode select bit is "1"), you must invoke software commands to access flash memory area.

The following shows how to access the flash memory area using script commands, the dump window, and the RAM monitor window.

(1) Using Script Commands

To execute Fill and Dump commands to the flash memory area, you need to issue software commands. When flash memory is enabled, software commands can be used. You can use the FillWord or setMemoryWord commands to write software command code to the user ROM area. In the read array mode or the read status register mode, the DumpWord command allows you to read values from flash memory or status register, respectively.

Example 1: To read values from flash memory

If you want to read a value from flash memory, you must first select the read array mode. Use the FillWord or setMemoryWord command to write the read array command (FFh) to the user ROM area. In the read array mode, the DumpWord command allows you to read values from flash memory.

Example 2: To rewrite data to flash memory

If you want to rewrite data to flash memory, use the FillWord or setMemoryWord command to write the program command (40h) to the user ROM area, then write the data to the address to be programmed. Note that, because you are in the read status register mode, to check that the data has been written, first invoke the read array command, as in Example 1, then read the data.

If the data was not FFFFh prior to being programmed, the data after being programmed may differ from the data that was written. The post-programming data is the AND value of the pre-programming data and the data that was written.

Example 3: To block-erase flash memory

If you want to block-erase flash memory, use the FillWord or setMemoryWord command to write 20h to the user ROM area, then write D0h to the address of the block to be erased. Note that, because you are in read status register mode, to check that the data has been erased, first invoke the read array command, as in Example 1, then read the data.

(2) Using the Dump Window

When flash memory is enabled, the values of flash memory or status register are displayed in the read array mode or the read status register mode, respectively. Take note that after writing to or erasing flash memory, the values of the status register is displayed in the read status register mode.

If flash memory is enabled, software commands are valid and the procedure for invoking the software commands can be performed in the dump window. If the FillWord or setMemoryWord command is used from the dump window as in (1) above to perform a write operation, you can change the mode of flash memory and program and erase flash memory via the dump window.

(3) Using the RAM Monitor Window

When flash memory is enabled, the values of flash memory or status register are displayed in the read array mode or the read status register mode, respectively. (If you have changed mode, press the "Clear" button to update the data display, which is not updated automatically when you change modes.) See (1) and (2) above for details of how to select the read array mode and the read status register mode.

4.5 Precautions for CPU Rewrite Mode

Here following are precautions and restrictions for debugging the control program for CPU rewrite mode.

IMPORTANT

Note on Custom Command `dbg_reset`:

- To debug the control program for CPU rewrite mode, you must execute the custom command `dbg_reset` once every time you start emulator debugger M3T-PD30.

If you set the MAP setting of addresses E0000h to FFFDFh to "EXT" without executing `dbg_reset`, the emulator will run out of control.

Note on CNVSS:

- To debug the control program for CPU rewrite mode, you need to apply 4.5 to 5.5 V voltage to the CNVSS pin.

When the target system is connected:

Set the jumper switch JP1 of the M30220TF-PRB to "CNVSS". The CNVSS is connected to the target system. Apply 4.5V to 5.5V voltage to the CNVSS pin of the target system.

When the target system is NOT connected:

Set the jumper switch JP1 of the M30220TF-PRB to "VDD". 5V voltage is applied from the emulation pod to the CNVSS.

Note on Address E0000h - FFFDFh Memory:

- Table 4.5 shows the areas of memory addresses E0000h to FFFDFh that are enabled according to the MAP setting and the value of the CPU rewrite mode select bit (FMCR1).

Table 4.5 Memory addresses E0000h to FFFDFh

Map setting	FMCR1 setting	Valid area	Remarks
INT	0	Emulation memory	
	1	-	Forbidden*1
EXT	0	No valid area	
	1	MCU's internal flash memory	

*1. When both the MAP setting for addresses E0000h to FFFDFh is "INT" and the FMCR1 is set to "1", both the emulation memory and the MCU's internal flash memory are enabled and bus collisions can occur. Please avoid combining these settings.

When both the MAP setting for addresses E0000h to FFFDFh is "EXT" and the FMCR1 is set to "0", no memory area is enabled and undefined values will be read.

Note on Boot Mode:

- Even when the P74 (CE) pin is "H" and the CNVSS pin is "H", boot mode cannot be selected when the reset is released.

If you want to debug the control program for CPU rewrite mode using operations as in boot mode, download DE000h to the reset vector area as well as the control program. If you do not download the reset vector, use script commands, etc., to write DE000h to the reset vector area.

IMPORTANT

Notes on Setting Software Breaks:

- When setting software breaks in the control program for CPU rewrite mode transferred to the RAM area, set the software break points after making the transfer. The software breaks will not function if you set them before the program is transferred to the RAM area.
- When setting "1" in the CPU rewrite mode select bit, you must write "0" followed consecutively by "1". When a software break is set to the instruction to write "0", you will not be able to set "1" in the CPU rewrite mode select bit even if you run the program from this instruction.
If you run the program from this instruction after canceling the software break at this instruction, you will be able to set "1" in the CPU rewrite mode select bit.

Note on RESET from the Target System:

- When the reset vector value is at a user ROM area address, the CPU will run out of control when reset from the target if the MAP setting for addresses E0000h to FFFDFh is set to "EXT". This is because undefined values are read, as shown in "Note on Address E0000h - FFFDFh Memory" (page 37). When the MAP setting is "INT", resets from the target function normally.

Note on Setting the CPU Rewrite Mode Select Bit:

- Normal script commands cannot be used to set the CPU rewrite mode select bit to "1". However, you can use the custom command `fmcrlset` to set this bit to "1". (See section 4.2 (2).)

Note on Address FFFE0h - FFFFFh:

- Addresses FFFE0h to FFFFFh are used for tool control, and the MCU's internal flash memory is therefore not enabled. Therefore you cannot erase or program addresses FFFE0h to FFFFFh.
Also, software commands in addresses FFFE0h to FFFFFh cannot be accepted.

Note on Changing the Mode of Flash Memory:

- If you change the mode of flash memory during debugging, the control program may not run as normal.

Note on Step Execution:

- Do not source-line step an instruction jumping to the RAM area. Otherwise, the emulator will be out of control. You can, however, step (machine language level step execution) an instruction jumping to the RAM area.

Example for stepping an instruction:

Execute the script command `StepInstruction(SI)` by the script window.

> SI <RET>

IMPORTANT

Note on Number of Program/Erase:

- Flash memory is capable of 100 program/erase operations. If you are performing more than 100 program/erase operations, please replace the M30220TF-PRB with a new one.

Note on Shutting OFF the Power:

- When switching off the power supply to the emulator itself, first select read array mode or either press emulator debugger M3T-PD30 "RESET" button or the reset button of the emulator itself to protect the flash memory.

MEMO

Chapter 5. Specifications

This chapter describes specifications of this product.

5.1 Specifications	42
5.2 External Dimensions	43
(1) External Dimensions of the Pod Probe	43
(2) External Dimensions of the Converter Board (FLX-144NSD)	43
(3) External Dimensions of the Converter Board (FLX-144NSE)	44
(4) External Dimensions of the Converter Board (FLX-120NSE)	44

Chapter 5. Specifications

5.1 Specifications

Table 5.1 lists the specifications of the M30220TF-PRB.

Table 5.1 Specifications of the M30220TF-PRB

Emulators	PC4701	
Emulation pod main unit	M30200T-RPD-E	
Applicable MCUs	M30220 and M30221 Group MCUs	
Usable MCU mode	Single-chip mode	
Emulation memory	1 MB	
Flash memory	(128 K - 32) bytes (Address E0000h - FFFDFh; For how to use the flash memory, refer to Chapter 4.)	
Program/erase iterations of flash memory	Guaranteed for only 100 program/erase iterations	
Operating power voltage	2.7 - 5.5 V	
Operating frequency	4.0 - 5.5 V	10.0 MHz
	2.7 - 5.5 V	7.0 MHz, 1-wait
Operating frequency in CPU rewrite mode	For no-wait: 5.0 MHz or less	
	For 1-wait: 10.0 MHz or less	
Stack capacity for the emulator	Max. 8 bytes	
Suspended cycles in run-time debug	16-byte dump: approx. 312 BCLK cycles 16-byte fill: approx. 283 BCLK cycles	
Power supply to emulation pod	1. Supplied from the emulator main unit 2. The operating voltage of the emulation pod main unit is determined by detecting the supply voltage of the target system. When no target system is connected, or when the supply voltage of the target system is more than 5.0 V, the operating voltage is 5.0 V.	
Operating temperature range	5 to 35°C (no dew) 20 to 30°C (in CPU rewrite mode)	
Storage temperature range	-10 to 60°C (no dew)	
Connection to the target system See "3.4 Connecting the Target System" (page 22).	M30220 Group: FLX-144NSD (separately available) for 144-pin 0.5-mm-pitch LQFP (144P6Q-A) FLX-144NSE (separately available) for 144-pin 0.4-mm-pitch TQFP (144PFB-A)	
	M30221 Group: FLX-120NSE (separately available) for 120-pin 0.4-mm-pitch LQFP (120P6R-A)	

5.2 External Dimensions

(1) External Dimensions of the Pod Probe

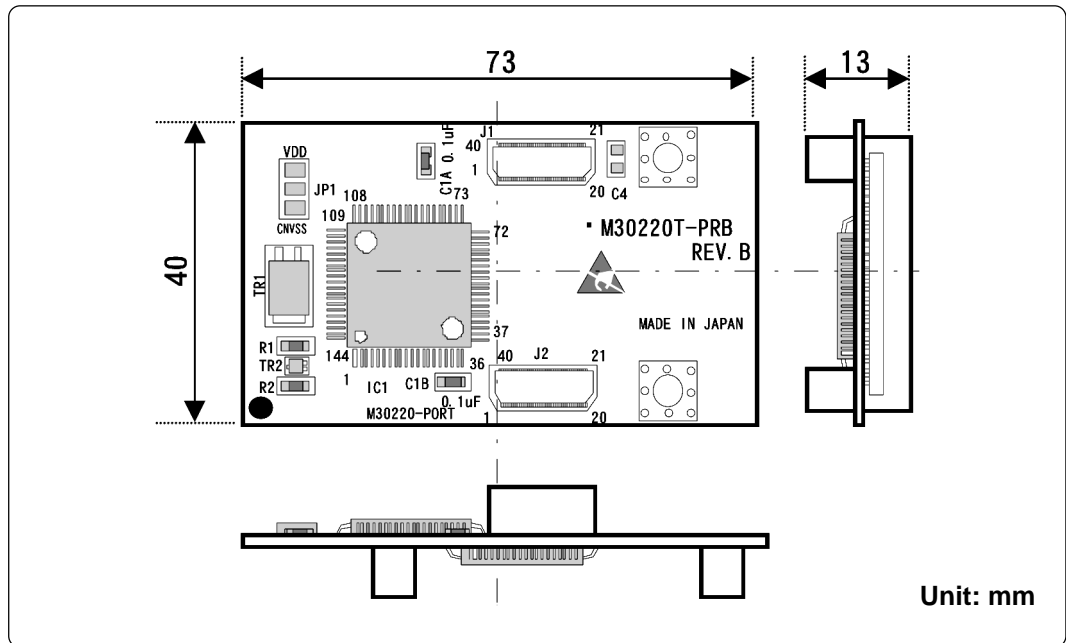

Figure 5.1 External dimensions of the M30220TF-PRB

(2) External Dimensions of the Converter Board (FLX-144NSD)

Figure 5.2 shows the external dimensions and a sample foot pattern of the pitch converter board FLX-144NSD for 144-pin 0.5-mm-pitch LQFP.

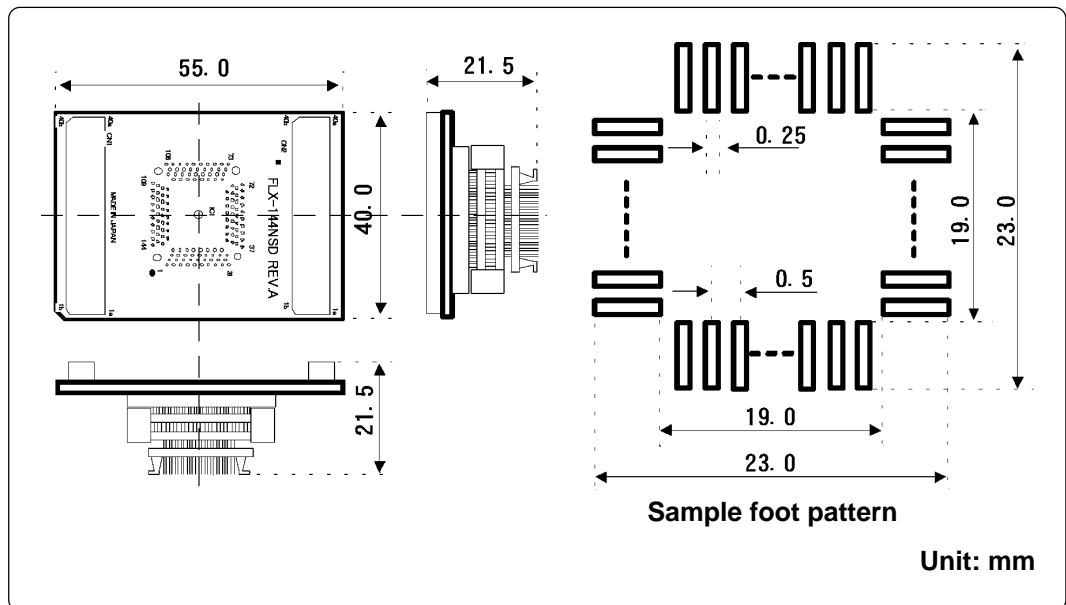

Figure 5.2 External dimensions of the FLX-144NSD

(3) External Dimensions of the Converter Board (FLX-144NSE)

Figure 5.3 shows the external dimensions and a sample foot pattern of the pitch converter board FLX-144NSE for 144-pin 0.4-mm-pitch TQFP.

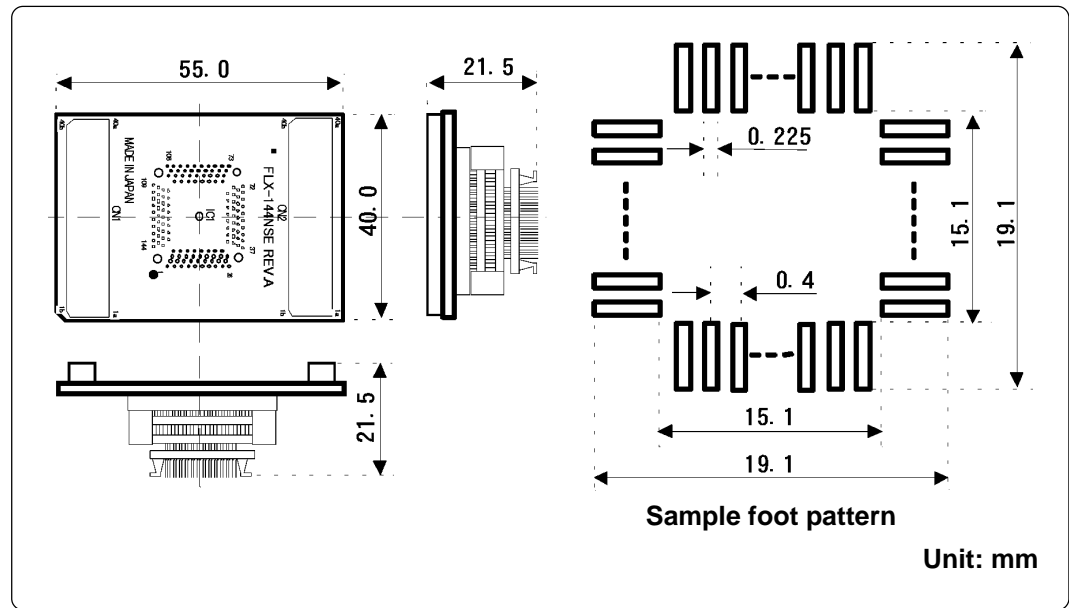

Figure 5.3 External dimensions of the FLX-144NSE

(4) External Dimensions of the Converter Board (FLX-120NSE)

Figure 5.4 shows the external dimensions and a sample foot pattern of the pitch converter board FLX-120NSE for 120-pin 0.4-mm-pitch LQFP.

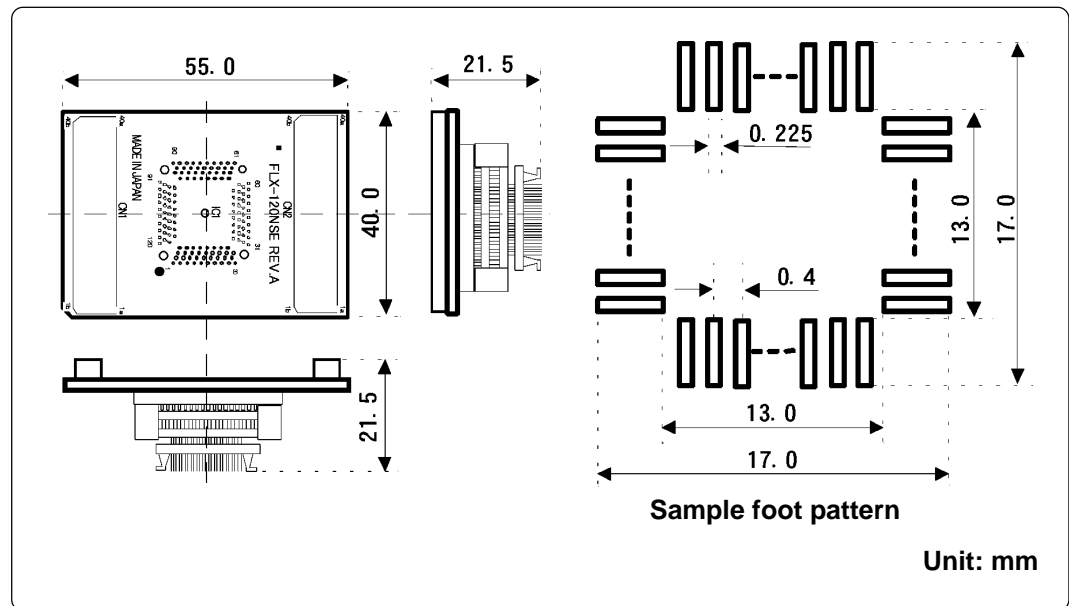

Figure 5.4 External dimensions of the FLX-120NSE

Chapter 6. Troubleshooting

This chapter describes how to troubleshoot when this product does not work properly.

6.1	When the Emulator Debugger Does Not Start Up Properly	46
	(1) When the LED Display of PC4701 is Abnormal	46
	(2) Errors Occur When Starting Up the Emulator Debugger (When the target system is connected)	47
	(3) Errors Occur When Starting Up the Emulator Debugger (When the target system is not connected)	48
6.2	Operation Differs from That of Actual MCUs	48

Chapter 6. Troubleshooting

When this product does not work properly, check the following.

For the latest FAQs, refer to the URL below.

<http://www.renesas.com/en/tools>

6.1 When the Emulator Debugger Does Not Start Up Properly

(1) When the LED Display of PC4701 is Abnormal

Table 6.1 LED's abnormal display and its checkpoints

Error	Connection to the target system	Checkpoint
LEDs do not light up.	-	Recheck the power cable is connected to the PC4701. <i>See the PC4701 User's Manual.</i>
All LEDs remain lit.	-	(1) Recheck the connection between the M30200T-RPD-E and this product. <i>See "3.3 Connecting the M30200T-RPD-E" (page 21).</i> (2) Recheck the connection between the PC4701 and the M30200T-RPD-E. <i>See the M30200T-RPD-E User's Manual.</i>
The POWER LED of "STATUS OF TARGET" does not light up.	Connected	Check power is properly supplied to the target system and that the target system is properly grounded.
The CLOCK LED of "STATUS OF TARGET" does not light up.	Disconnected	(1) Check that both the main and sub clocks of the emulator debugger are not set to "EXT". <i>See the CLK command of the emulator debugger.</i> (2) Check the oscillation circuit in the M30200T-RPD-E is oscillating. <i>See the M30200T-RPD-E User's Manual.</i>
	Connected	(1) Check the oscillation circuit in the target system is oscillating properly. (2) Check the switches of the FLX64-PRB are correctly set. <i>See "3.1 Switch Settings" (page 18).</i>
The RESET LED of "STATUS OF TARGET" does not go out.	Connected	Check if the reset pin of the target system is pulled up.

**(2) Errors Occur When Starting Up the Emulator Debugger
(When the target system is connected)**

Table 6.2 Checkpoints of errors when starting up the emulator debugger (target is connected)

Error	Checkpoint
Communication ERROR Data is not sent to the target	Check all emulator debugger settings, interface cable connections and switches on the rear of the PC4701 match. <i>See the user's manuals of the PC4701 and emulator debugger.</i>
Target system is not constructed properly	(1) Download the proper firmware. <i>See the user's manual of the emulator debugger.</i> (2) Recheck the connection between the M30200T-RPD-E and this product. <i>See "3.3 Connecting the M30200T-RPD-E" (page 21).</i> (3) Recheck the connection between the PC4701 and the M30200T-RPD-E. <i>See the M30200T-RPD-E User's Manual.</i>
The version of M3T-PD30 and the firmware on the target system are not same	Download the proper firmware. <i>See the user's manual of the emulator debugger.</i>
Target MCU is reset state	(1) Check the reset pin of the target system is pulled up. (2) Check the reset pin of the target system has changed from "L" to "H" level.
Target MCU cannot be reset	(1) Check the NMI* pin is "H" level. (2) If the reset circuit of the target system has a watchdog timer, disable the timer. (3) Check power is properly supplied to the target system and that the target system is properly grounded.
Target MCU is in "HOLD" state	The MCU is either in the stop mode or wait mode. Either reset the MCU or cancel the mode with an interrupt. <i>See MCU specifications.</i>
Target clock is stopped	(1) Check the oscillation circuit in the target system is oscillating properly. (2) Check the switches of the FLX64-PRB are correctly set. <i>See "3.1 Switch Settings" (page 18).</i>
Target MCU is not receiving power	Check power is properly supplied to the target system and that the target system is properly grounded.

(3) Errors Occur When Starting Up the Emulator Debugger (When the target system is not connected)

Table 6.3 Checkpoints of errors when starting up emulator debugger (target is not connected)

Error	Checkpoint
Communication ERROR Data is not sent to the target	Check all emulator debugger settings, interface cable connections and switches on the rear of the PC4701 match. <i>See the user's manuals of the PC4701 and emulator debugger.</i>
Target system is not constructed properly	(1) Download the proper firmware. <i>See the user's manual of the emulator debugger.</i> (2) Recheck the connection between the M30200T-RPD-E and this product. <i>See "3.3 Connecting the M30200T-RPD-E" (page 21).</i> (3) Recheck the connection between the PC4701 and the M30200T-RPD-E. <i>See the M30200T-RPD-E User's Manual.</i>
The version of M3T-PD30 and the firmware on the target are not same	Download the proper firmware. <i>See the user's manual of the emulator debugger.</i>
Target MCU is in "HOLD" state	The MCU is either in the stop mode or wait mode. Either reset the MCU or cancel the mode with an interrupt. <i>See MCU specifications.</i>
Target clock is stopped	Check the switches of the FLX64-PRB are correctly set. <i>See "3.1 Switch Settings" (page 18).</i>

6.2 Operation Differs from That of Actual MCUs

Make note of the fact that the operation when using the emulation pod differs from that of actual MCUs as follows.

(1) Initializing the internal resources of MCU at power-on

(2) Internal memories (ROM and RAM) capacities, etc.

With this emulator system, "INT" (emulation memory ON) is the default for mapping areas other than the SFR area (addresses 000h - 3FFh). For this reason, the emulation memory can read and write in areas other than the SFR, internal RAM and internal ROM.

(3) Oscillator circuit

- Make note of the fact that in the oscillator circuit where a resonator is connected between the X_{IN} and X_{OUT} pins, oscillation does not occur because a flexible cable, buffer IC and other devices are used between the evaluation MCU and the target system. It is same for sub-clock oscillator circuits (X_{CIN} and X_{COU}T).
- For note on when using the oscillator circuit on the target system, refer to "4.2 (2) Using target system's oscillator" (page 21) in the M30200T-RPD-E User's Manual.

(4) X_{OUT} pin

The X_{OUT} pin is not assigned to the evaluation MCU used by this product. For this reason, the X_{OUT} pin of this product is open.

(5) DBC, single-step and BRK instruction interrupt vector table addresses

It is possible to download to DBC, single-step and BRK instruction interrupt vector table addresses. However, because the emulator system uses these areas, data different from the expected value is read out.

(6) A-D conversion

The characteristics of A-D converter differ from those of actual MCU because there are a flexible cable, pitch converter and other devices between the evaluation MCU and the target system. Make the final evaluation of the A-D converter with the actual MCU.

(7) D-A conversion

The characteristics of D-A converter differ from those of actual MCU because there are a flexible cable, pitch converter and other devices between the evaluation MCU and the target system. Make the final evaluation of the D-A converter with the actual MCU.

Chapter 7. Maintenance and Warranty

This chapter describes how to maintenance, repair provisions and how to request for repair.

7.1 Maintenance	50
7.2 Warranty	50
7.3 Repair Provisions.....	50
7.4 How to Request for Repair	51

Chapter 7. Maintenance and Guarantee

7.1 Maintenance

If dust or dirt collects on any equipment of your emulation system, wipe it off with a dry soft cloth. Do not use thinner or other solvents because these chemicals can cause the equipment's surface coating to separate.

7.2 Guarantee

If your product becomes faulty within twelve months after its purchase while being used under good conditions by observing "Precautions for Safety" described in Chapter 1 of this user's manual, we will repair or replace your faulty product free of charge. Note, however, that if your product's fault is raised by any one of the following causes, we will repair it or replace it with new one with extra-charge:

- Misuse, abuse, or use under extraordinary conditions
- Unauthorized repair, remodeling, maintenance, and so on
- Inadequate user's system or misuse of it
- Fires, earthquakes, and other unexpected disasters

In the above cases, contact your local distributor. If your product is being leased, consult the leasing company or the owner.

7.3 Repair Provisions

(1) Repair with extra-charge

The products elapsed more than twelve months after purchase can be repaired with extra-charge.

(2) Replacement with extra-charge

If your product's fault falls in any of the following categories, the fault will be corrected by replacing the entire product instead of repair, or you will be advised to purchase new one, depending on the severity of the fault.

- Faulty or broken mechanical portions
- Flaw, separation, or rust in coated or plated portions
- Flaw or cracks in plastic portions
- Faults or breakage caused by improper use or unauthorized repair or modification
- Heavily damaged electric circuits due to overvoltage, overcurrent or shorting of power supply
- Cracks in the printed circuit board or burnt-down patterns
- Wide range of faults that makes replacement less expensive than repair
- Unlocatable or unidentified faults

(3) Expiration of the repair period

When a period of twelve months elapses after the model was dropped from production, repairing products of the model may become impossible.

(4) Transportation fees at sending your product for repair

Please send your product to us for repair at your expense.

7.4 How to Request for Repair

If your product is found faulty, follow the procedure below to send your product for repair.

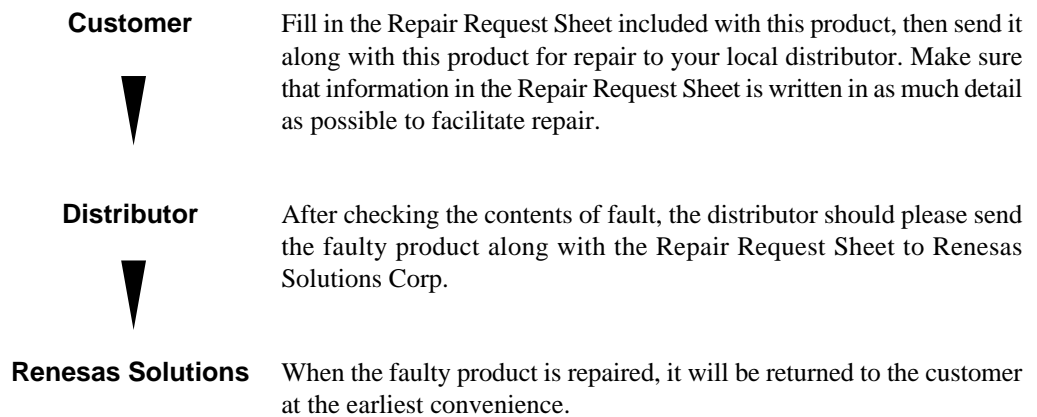

CAUTION

Note on Transporting the Product:



- When sending your product for repair, use the packing box and cushion material supplied with this product when delivered to you and specify handling caution for it to be handled as precision equipment. If packing of your product is not complete, it may be damaged during transportation. When you pack your product in a bag, make sure to use conductive polyvinyl supplied with this product (usually a blue bag). When you use other bags, they may cause a trouble on your product because of static electricity.

MEMO

M30220TF-PRB User's Manual

Rev.1.00
September 1, 2003
REJ10J0280-0100Z

COPYRIGHT ©2003 RENESAS TECHNOLOGY CORPORATION
AND RENESAS SOLUTIONS CORPORATION ALL RIGHTS RESERVED

M30220TF-PRB
User's Manual



Renesas Electronics Corporation

1753, Shimonumabe, Nakahara-ku, Kawasaki-shi, Kanagawa 211-8668 Japan

REJ10J0280-0100Z