

To our customers,

Old Company Name in Catalogs and Other Documents

On April 1st, 2010, NEC Electronics Corporation merged with Renesas Technology Corporation, and Renesas Electronics Corporation took over all the business of both companies. Therefore, although the old company name remains in this document, it is a valid Renesas Electronics document. We appreciate your understanding.

Renesas Electronics website: <http://www.renesas.com>

April 1st, 2010
Renesas Electronics Corporation

Issued by: Renesas Electronics Corporation (<http://www.renesas.com>)

Send any inquiries to <http://www.renesas.com/inquiry>.

Notice

1. All information included in this document is current as of the date this document is issued. Such information, however, is subject to change without any prior notice. Before purchasing or using any Renesas Electronics products listed herein, please confirm the latest product information with a Renesas Electronics sales office. Also, please pay regular and careful attention to additional and different information to be disclosed by Renesas Electronics such as that disclosed through our website.
2. Renesas Electronics does not assume any liability for infringement of patents, copyrights, or other intellectual property rights of third parties by or arising from the use of Renesas Electronics products or technical information described in this document. No license, express, implied or otherwise, is granted hereby under any patents, copyrights or other intellectual property rights of Renesas Electronics or others.
3. You should not alter, modify, copy, or otherwise misappropriate any Renesas Electronics product, whether in whole or in part.
4. Descriptions of circuits, software and other related information in this document are provided only to illustrate the operation of semiconductor products and application examples. You are fully responsible for the incorporation of these circuits, software, and information in the design of your equipment. Renesas Electronics assumes no responsibility for any losses incurred by you or third parties arising from the use of these circuits, software, or information.
5. When exporting the products or technology described in this document, you should comply with the applicable export control laws and regulations and follow the procedures required by such laws and regulations. You should not use Renesas Electronics products or the technology described in this document for any purpose relating to military applications or use by the military, including but not limited to the development of weapons of mass destruction. Renesas Electronics products and technology may not be used for or incorporated into any products or systems whose manufacture, use, or sale is prohibited under any applicable domestic or foreign laws or regulations.
6. Renesas Electronics has used reasonable care in preparing the information included in this document, but Renesas Electronics does not warrant that such information is error free. Renesas Electronics assumes no liability whatsoever for any damages incurred by you resulting from errors in or omissions from the information included herein.
7. Renesas Electronics products are classified according to the following three quality grades: “Standard”, “High Quality”, and “Specific”. The recommended applications for each Renesas Electronics product depends on the product’s quality grade, as indicated below. You must check the quality grade of each Renesas Electronics product before using it in a particular application. You may not use any Renesas Electronics product for any application categorized as “Specific” without the prior written consent of Renesas Electronics. Further, you may not use any Renesas Electronics product for any application for which it is not intended without the prior written consent of Renesas Electronics. Renesas Electronics shall not be in any way liable for any damages or losses incurred by you or third parties arising from the use of any Renesas Electronics product for an application categorized as “Specific” or for which the product is not intended where you have failed to obtain the prior written consent of Renesas Electronics. The quality grade of each Renesas Electronics product is “Standard” unless otherwise expressly specified in a Renesas Electronics data sheets or data books, etc.
 - “Standard”: Computers; office equipment; communications equipment; test and measurement equipment; audio and visual equipment; home electronic appliances; machine tools; personal electronic equipment; and industrial robots.
 - “High Quality”: Transportation equipment (automobiles, trains, ships, etc.); traffic control systems; anti-disaster systems; anti-crime systems; safety equipment; and medical equipment not specifically designed for life support.
 - “Specific”: Aircraft; aerospace equipment; submersible repeaters; nuclear reactor control systems; medical equipment or systems for life support (e.g. artificial life support devices or systems), surgical implantations, or healthcare intervention (e.g. excision, etc.), and any other applications or purposes that pose a direct threat to human life.
8. You should use the Renesas Electronics products described in this document within the range specified by Renesas Electronics, especially with respect to the maximum rating, operating supply voltage range, movement power voltage range, heat radiation characteristics, installation and other product characteristics. Renesas Electronics shall have no liability for malfunctions or damages arising out of the use of Renesas Electronics products beyond such specified ranges.
9. Although Renesas Electronics endeavors to improve the quality and reliability of its products, semiconductor products have specific characteristics such as the occurrence of failure at a certain rate and malfunctions under certain use conditions. Further, Renesas Electronics products are not subject to radiation resistance design. Please be sure to implement safety measures to guard them against the possibility of physical injury, and injury or damage caused by fire in the event of the failure of a Renesas Electronics product, such as safety design for hardware and software including but not limited to redundancy, fire control and malfunction prevention, appropriate treatment for aging degradation or any other appropriate measures. Because the evaluation of microcomputer software alone is very difficult, please evaluate the safety of the final products or system manufactured by you.
10. Please contact a Renesas Electronics sales office for details as to environmental matters such as the environmental compatibility of each Renesas Electronics product. Please use Renesas Electronics products in compliance with all applicable laws and regulations that regulate the inclusion or use of controlled substances, including without limitation, the EU RoHS Directive. Renesas Electronics assumes no liability for damages or losses occurring as a result of your noncompliance with applicable laws and regulations.
11. This document may not be reproduced or duplicated, in any form, in whole or in part, without prior written consent of Renesas Electronics.
12. Please contact a Renesas Electronics sales office if you have any questions regarding the information contained in this document or Renesas Electronics products, or if you have any other inquiries.

(Note 1) “Renesas Electronics” as used in this document means Renesas Electronics Corporation and also includes its majority-owned subsidiaries.

(Note 2) “Renesas Electronics product(s)” means any product developed or manufactured by or for Renesas Electronics.

M302N2T-PRB

User's Manual

Pod Probe for M302N1 and M302N2 Group
MCUs

- TQPACK080SB, TQSOCKET080SBG, YQPACK056SB, NQPACK056SB and YQ-GUIDE are products of Tokyo Eletech Corporation.

Keep safety first in your circuit designs!

- Renesas Technology Corporation and Renesas Solutions Corporation put the maximum effort into making semiconductor products better and more reliable, but there is always the possibility that trouble may occur with them. Trouble with semiconductors may lead to personal injury, fire or property damage. Remember to give due consideration to safety when making your circuit designs, with appropriate measures such as (i) placement of substitutive, auxiliary circuits, (ii) use of nonflammable material or (iii) prevention against any malfunction or mishap.

Notes regarding these materials

- These materials are intended as a reference to assist our customers in the selection of the Renesas Technology product best suited to the customer's application; they do not convey any license under any intellectual property rights, or any other rights, belonging to Renesas Technology Corporation, Renesas Solutions Corporation or a third party.
- Renesas Technology Corporation and Renesas Solutions Corporation assume no responsibility for any damage, or infringement of any third-party's rights, originating in the use of any product data, diagrams, charts, programs, algorithms, or circuit application examples contained in these materials.
- All information contained in these materials, including product data, diagrams, charts, programs and algorithms represents information on products at the time of publication of these materials, and are subject to change by Renesas Technology Corporation and Renesas Solutions Corporation without notice due to product improvements or other reasons. It is therefore recommended that customers contact Renesas Technology Corporation, Renesas Solutions Corporation or an authorized Renesas Technology product distributor for the latest product information before purchasing a product listed herein. The information described here may contain technical inaccuracies or typographical errors. Renesas Technology Corporation and Renesas Solutions Corporation assume no responsibility for any damage, liability, or other loss rising from these inaccuracies or errors. Please also pay attention to information published by Renesas Technology Corporation and Renesas Solutions Corporation by various means, including the Renesas home page (<http://www.renesas.com>).
- When using any or all of the information contained in these materials, including product data, diagrams, charts, programs, and algorithms, please be sure to evaluate all information as a total system before making a final decision on the applicability of the information and products. Renesas Technology Corporation and Renesas Solutions Corporation assume no responsibility for any damage, liability or other loss resulting from the information contained herein.
- Renesas Technology semiconductors are not designed or manufactured for use in a device or system that is used under circumstances in which human life is potentially at stake. Please contact Renesas Technology Corporation, Renesas Solutions Corporation or an authorized Renesas Technology product distributor when considering the use of a product contained herein for any specific purposes, such as apparatus or systems for transportation, vehicular, medical, aerospace, nuclear, or undersea repeater use.
- The prior written approval of Renesas Technology Corporation and Renesas Solutions Corporation is necessary to reprint or reproduce in whole or in part these materials.
- If these products or technologies are subject to the Japanese export control restrictions, they must be exported under a license from the Japanese government and cannot be imported into a country other than the approved destination. Any diversion or reexport contrary to the export control laws and regulations of Japan and/or the country of destination is prohibited.
- Please contact Renesas Technology Corporation or Renesas Solutions Corporation for further details on these materials or the products contained therein.

Precautions to be taken when using this product

- This product is a development supporting unit for use in your program development and evaluation stages. In mass-producing your program you have finished developing, be sure to make a judgment on your own risk that it can be put to practical use by performing integration test, evaluation, or some experiment else.
- In no event shall Renesas Solutions Corporation be liable for any consequence arising from the use of this product.
- Renesas Solutions Corporation strives to renovate or provide a workaround for product malfunction at some charge or without charge. However, this does not necessarily mean that Renesas Solutions Corporation guarantees the renovation or the provision under any circumstances.
- This product has been developed by assuming its use for program development and evaluation in laboratories. Therefore, it does not fall under the application of Electrical Appliance and Material Safety Law and protection against electromagnetic interference when used in Japan.

For inquiries about the contents of this document or product, fill in the text file the installer of the emulator debugger generates in the following directory and email to your local distributor.

\\SUPPORT\Product-name\SUPPORT.TXT

Renesas Tools Homepage <http://www.renesas.com/en/tools>

Preface

The M302N2T-PRB is a pod probe for the M302N1 and M302N2 Group of Renesas 16-bit MCUs. The M302N2T-PRB is used by connecting to the PC4701 emulator main unit and the M30200T-RPD-E emulation pod main unit.

This manual mainly explains specifications and how to set up the M302N2T-PRB. For detail information about the emulator main unit, emulation pod main unit, and emulator debugger, refer to each user's manual.

Emulator main unit:	PC4701 User's Manual
Emulation pod main unit:	M30200T-RPD-E User's Manual
Emulator debugger:	M3T-PD30 User's Manual

To check the components of this product, refer to "Table 2.1 Package Components" (page 14) in this manual. If there is any question or doubt about this product, contact your local distributor.

To use the product properly

Precautions for Safety:



- Both in this User's Manual and on the product itself, several icons are used to insure proper handling of this product and also to prevent injuries to you or other persons, or damage to your properties.
- The icons' graphic images and meanings are given in "Chapter 1. Precautions for Safety". Be sure to read this chapter before using the product.

Contents

Terminology	5
Chapter 1. Precautions for Safety	7
1.1 Safety Symbols and Meanings	8
Chapter 2. Preparation	13
2.1 Package Components	14
2.2 Other Tool Products Required for Development	14
2.3 System Configuration.....	15
Chapter 3. Setting Up	17
3.1 Switch Settings	18
3.2 A-D Conversion Bypass Capacitor	19
3.3 Connecting the M30200T-RPD-E.....	20
3.4 Connecting the Target System	21
3.5 Procedure for Making MCU File for M3T-PD30	24
Chapter 4. Specifications	25
4.1 Specifications	26
4.2 External Dimensions	27
(1) External Dimensions of Pod Probe	27
(2) External Dimensions of Converter Board (FLX-80QSB).....	27
(3) External Dimensions of Converter Board (M302N1T-56FPB)	28
Chapter 5. Troubleshooting	29
5.1 When the Emulator Debugger Does Not Start Up Properly	30
(1) When the LED Display of PC4701 is Abnormal	30
(2) Errors Occur When Starting Up the Emulator Debugger (When the target system is connected).....	31
(3) Errors Occur When Starting Up the Emulator Debugger (When the target system is not connected)	32
5.2 Operation Differs from That of Actual MCUs	32
Chapter 6. Maintenance and Warranty	33
6.1 Maintenance	34
6.2 Warranty	34
6.3 Repair Provisions	34
6.4 How to Request for Repair	35

Terminology

Some specific words used in this user's manual are defined as follows:

Emulation pod main unit

This means the emulation pod M30200T-RPD-E for the M16C/20 Series MCUs.

Emulator debugger

This means a software tool M3T-PD30 to control the emulator from the host machine through an interface.

Emulator main unit (Hereafter PC4701)

This means the generic name for emulators for 8 and 16-bit MCUs. For details on specific models of PC4701, visit Renesas Tools Homepage at <http://www.renesas.com/en/tools>

Emulator system

This means an emulator system built around the PC4701 emulator. The PC4701 emulator system is configured with an emulator main unit, emulation pod, pod probe, host machine and emulator debugger.

Evaluation MCU

This means the microcomputer mounted on the emulation pod which is operated in the specific mode for tools.

Firmware

Program that analyzes contents of communication with the emulator debugger and controls the emulator hardware. This program is installed in the EEPROM. This program is downloadable from the emulator debugger to upgrade the firmware or to support other MCUs.

Hardware break

A hardware break is a function to break the program when the system detects a write/read of data to/from memory or a rise/fall edge of the signal entered from the external trace cable. The former break function is called address break; and the latter break function is called trigger break. While the instruction at the address where the software break is set is not executed, a hardware break is performed after the specified instruction is executed.

Host machine

This means a personal computer used to control the emulator and emulation pod.

Pod probe

This means pod probe M302N2T-PRB (this product) for the M302N1 and M302N2 Groups.

Software break

A software break is a function to break the program before the system executes an instruction at the specified address. The instruction at the preset address will not be executed.

Target MCU

This means the MCU you are going to debug.

Target system

This means a user's application system using the MCU to be debugged.

*

In this user's manual, this symbol is used to show active LOW. (e.g. RESET*: Reset signal)

MEMO

Chapter 1. Precautions for Safety

This chapter describes precautions for using this product safely and properly. For precautions for the emulator main unit, the emulation pod main unit and the emulator debugger, refer to each user's manual included with your product.



1.1 Safety Symbols and Meanings	8
IMPORTANT Note on Final Evaluation	9
Note on Differences from Actual MCUs	9
Note on Clock Supply to the MCU	10
Notes on Interruption	10
Note on the Work Area	11
Note on MAP References and Settings	11
Note on Accessing SFR Area	11
Note on Commands that Access the Single-step Interrupt Vector Area	11

Chapter 1. Precautions for Safety

In both the user's manual and on the product itself, several icons are used to insure proper handling of this product and also to prevent injuries to you or other persons, or damage to your properties.

This chapter describes the precautions which should be taken in order to use this product safely and properly. Be sure to read this chapter before using this product.

1.1 Safety Symbols and Meanings

	WARNING	If the requirements shown in the "WARNING" sentences are ignored, the equipment may cause serious personal injury or death.
	CAUTION	If the requirements shown in the "CAUTION" sentences are ignored, the equipment may malfunction.
	IMPORTANT	It means important information on using this product.

In addition to the three above, the following are also used as appropriate.

△ means WARNING or CAUTION.
Example:  **CAUTION AGAINST AN ELECTRIC SHOCK**

⊘ means PROHIBITION.
Example:  **DISASSEMBLY PROHIBITED**

● means A FORCIBLE ACTION.
Example:  **UNPLUG THE POWER CABLE FROM THE RECEPTACLE.**

The following pages describe the symbol "IMPORTANT".

IMPORTANT

Note on Final Evaluation:

- Be sure to evaluate your system and make final confirmation with an CS (Commercial Sample) version MCU.

Note on Differences from Actual MCUs:

- Operations of the emulator system differ from those of mask MCUs as listed below.

(1) Initial values of internal resource data at power-on

(2) Internal memories (ROM and RAM) capacities, etc.

With this emulator system, "INT" (emulation memory ON) is the default for mapping areas other than the SFR area (addresses 000h - 3FFh). For this reason, the emulation memory can read and write in areas other than the SFR, internal RAM and internal ROM.

(3) Oscillator circuit

- Make note of the fact that in the oscillator circuit where a resonator is connected between the X_{IN} and X_{OUT} pins, oscillation does not occur because a flexible cable, buffer IC and other devices are used between the evaluation MCU and the target system. It is same for sub-clock oscillator circuits (X_{CIN} and X_{COUT}).
- For note on when using the oscillator circuit on the target system, refer to "4.2 (2) Using target system's oscillator" (page 21) of the M30200T-RPD-E User's Manual.

(4) X_{OUT} pin

The X_{OUT} pin is not assigned to the evaluation MCU used by this product. For this reason, the X_{OUT} pin of this product is open.

(5) DBC, single-step and BRK instruction interrupt vector table addresses

It is possible to download to DBC, single-step and BRK instruction interrupt vector table addresses. However, because the emulator system uses these areas, data different from the expected value is read out.

Table 1.1 Vector table addresses for the emulator

Factor of interruption	Vector table addresses	Data for reading
DBC*1	FFFF4h - FFFF7h	Indefinite
Single-step*1	FFFECh - FFFEFh	Indefinite
BRK instruction*1	FFFE4h - FFFE7h	Indefinite

*1 Interruption for the debugger only

(6) A-D conversion

The characteristics of A-D converter differ from those of actual MCU because there are a flexible cable, pitch converter and other devices between the evaluation MCU and the target system. Make the final evaluation of the A-D converter with the actual MCU.

IMPORTANT

Note on Clock Supply to the MCU:

- Clock can be supplied to the evaluation MCU in one of the following two ways. This is determined by emulator debugger clock selection.

(1) When Internal is selected:

The clock generated by the oscillation circuit in the emulation pod is supplied to the evaluation MCU. The clock is continually supplied to the evaluation MCU regardless of "target system clock status" and "user program execution status".

(2) When External is selected:

Clock supply to the evaluation MCU depends on oscillation status (oscillate/off) of the target system.

Notes on Interruption:

- Even when the target program is not being executed (while the target program is stopped or during runtime debugging), the emulation MCU keeps running so as to control the emulation pod. Therefore, note that timers and other components do not stop running even though the target program is not being executed.
- If a maskable interrupt request is generated when the target program is not being executed (while the target program is stopped or during runtime debugging), the request is not accepted because the emulator disables all interrupts. If an interrupt request is generated when the target program is not being executed, but the target program enables that interrupt, it will be accepted immediately after program execution starts.

IMPORTANT

Note on the Work Area:

- When using this product, set to "2C00h" as a start address of the work area at the time of starting up the emulator debugger (set by "F/W and Work Area" tab*1 of Init dialog). In this case, the emulator system uses the area below as a work area.

02C00h - 02C0Fh: Work area

*1 Supported by M3T-PD30 Ver.4.00 or later

Note on MAP References and Settings:

- When starting up the M30200T-RPD-E, initial MAP settings are as follows. Use generally the M30200T-RPD-E in this setting.

00000h to 003FFh: "EXT"

00400h to FFFFFh: "INT" (emulation memory available)

Note on Accessing SFR Area:

- Access the below four registers by byte. They cannot be correctly accessed by word.

003FCh: Pull-up control register 0 (PUR0)

003FDh: Up control register 1 (PUR1)

003FEh: Port P1 drive capacity control register (DDR)

003FFh: Up control register 2 (PUR2)

Note on Commands that Access the Single-step Interrupt Vector Area:

- Do not perform the below debugging operations with the single step interrupt vector area (addresses FFFECh - FFFEh).

(1) Step execution of commands that access the single step interrupt vector area

(2) Program execution using commands that access the single step interrupt vector area when a software breakpoint is set in those commands

MEMO

Chapter 2. Preparation

This chapter describes the package components, the system configuration and the preparation for using this product for the first time.

2.1 Package Components	14
2.2 Other Tool Products Required for Development	14
2.3 System Configuration	15

Chapter 2. Preparation

2.1 Package Components

This product consists of the following items. When unpacking, check to see if your product package contains all of these items.

Table 2.1 Package components

Item	Quantity
M302N2T-PRB pod probe for M302N1 and M302N2 Group MCUs	1
Screws (screws for fixing pod probe: pre-installed to the pod probe)	2
FLX-80QSB converter board for 80-pin 0.65-mm-pitch QFP (80P6S-A)	1
M302N2T-PRB User's Manual (this manual)	1
M302N2T-PRB User's Manual (Japanese)	1
M302N2T-PRB Repair Request Sheet (English/Japanese)	1

Please keep the M302N2T-PRB's packing box and cushion material in your place for reuse at a later time when sending your product for repair or other purposes. Always use these packing box and cushion material when transporting the M302N2T-PRB.

If any of these items are missing or found faulty, please contact your local distributor. Also, if there is any question or doubt about the packaged product, contact your local distributor.

2.2 Other Tool Products Required for Development

To bring forward programs development on the M302N1 and M302N2 Group MCUs, the products listed below are necessary in addition to the package components listed above. Get them separately.

Table 2.2 Other tool products

Emulator main unit	PC4701
Emulation pod main unit	M30200T-RPD-E
Emulator debugger	M3T-PD30 Ver.4.00 or later
Converter board	M302N1T-56FPB converter board for M302N1 Group MCUs (Necessary for evaluating M302N1 Group MCUs)

To purchase these products, contact your nearest distributor.

2.3 System Configuration

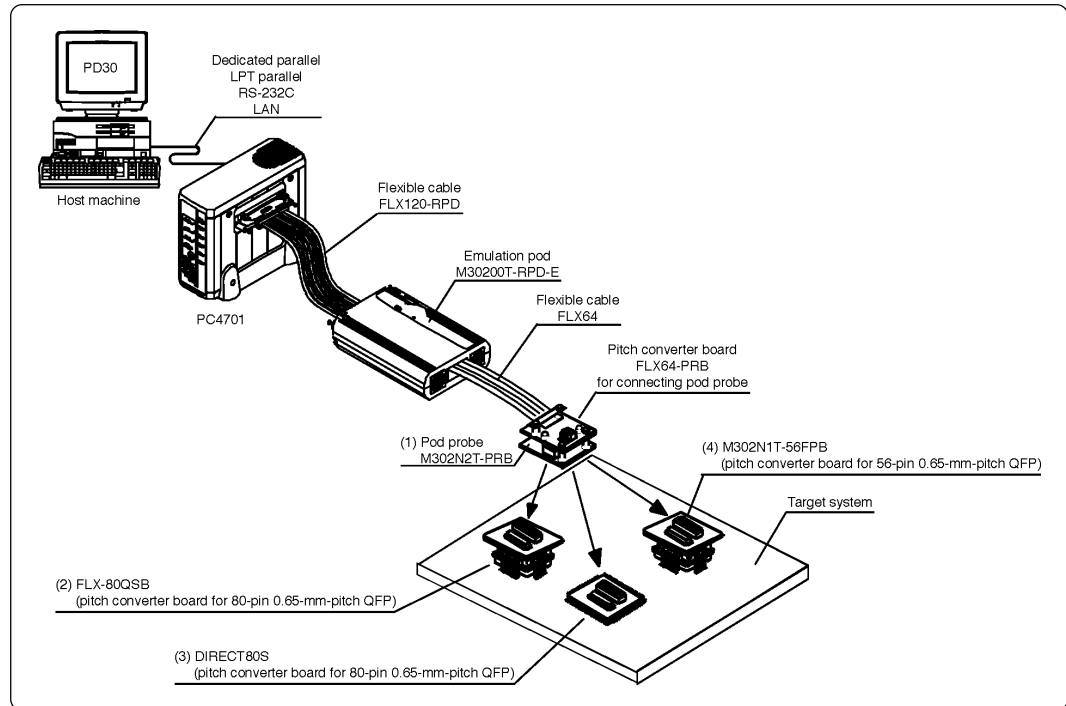

Figure 2.1 System configuration

Products (1) and (2) shown in Figure 2.1 are included with this product. Get (3) and (4) separately.

(1) Pod probe (M302N2T-PRB)

This pod probe is equipped with the evaluation MCU (M302NX-OTHERS).

(2) FLX-80QSB (converter board for 80-pin 0.65-mm-pitch QFP)

This is a pitch converter board (included) used for evaluating the M302N2 Group MCUs.

(3) DIRECT80S (converter board for 80-pin 0.65-mm-pitch QFP)

This is a pitch converter board (separately available) used for evaluating the M302N2 Group MCUs.

(4) M302N1T-56FPB (converter board for 56-pin 0.65-mm-pitch QFP)

This is a pitch converter board (separately available) used for evaluating the M302N1 Group MCUs.

For details on the connection, refer to "3.4 Connecting the Target System" (page 21).

MEMO

Chapter 3. Setting Up

This chapter describes switch settings required for using this product and how to connect this product to the PC4701 and the target system.

3.1 Switch Settings	18
3.2 A-D Conversion Bypass Capacitor	19
3.3 Connecting the M30200T-RPD-E	20
3.4 Connecting the Target System.....	21
3.5 Procedure for Making MCU File for M3T-PD30	24

Chapter 3. Setting Up

With this product, it is necessary to set the following according to your target system.

- Switching ports (P70 and P71) and sub-clock
- Mounting the A-D conversion bypass capacitor

3.1 Switch Settings

It is necessary to set the switches of the FLX64-PRB for debugging according to the target system. Figure 3.1 shows the positions of the switches of the FLX64-PRB, and Table 3.1 shows the switch settings.

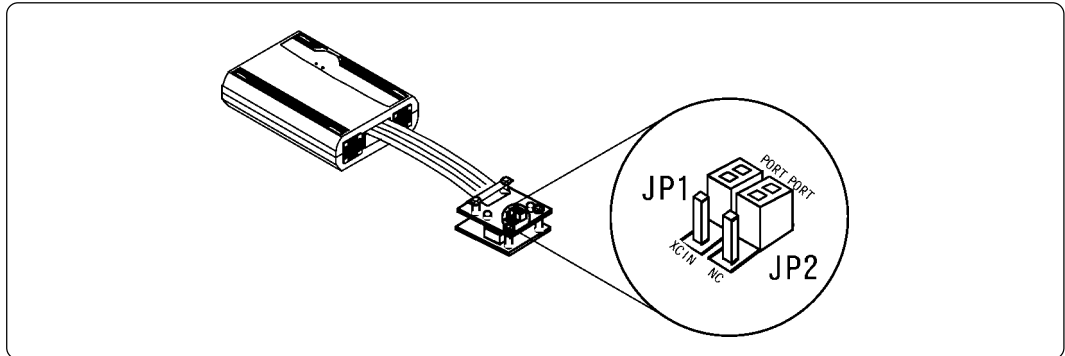

Figure 3.1 Positions of the switches and their factory-settings

Table 3.1 Switch settings of the FLX64-PRB

Switch No.	Function	Switch setting	
JP1	Switches P71/XCIN	<p>When using the port function (P71) (Factory-setting)</p>	<p>When using the sub-clock</p>
JP2	Switches P70/NC	<p>When using the port function (P70) (Factory-setting)</p>	<p>When using the sub-clock</p>

IMPORTANT

Note on Settings of JP1 and JP2:

- Change the switch setting of JP1 and JP2 at the same time as shown in Table 3.1.

3.2 A-D Conversion Bypass Capacitor

This product has foot patterns on the board for mounting a bypass capacitor for the A-D converter circuit. Mount a suitable bypass capacitor as occasion demands.

Figure 3.2 shows the position of the bypass capacitor.

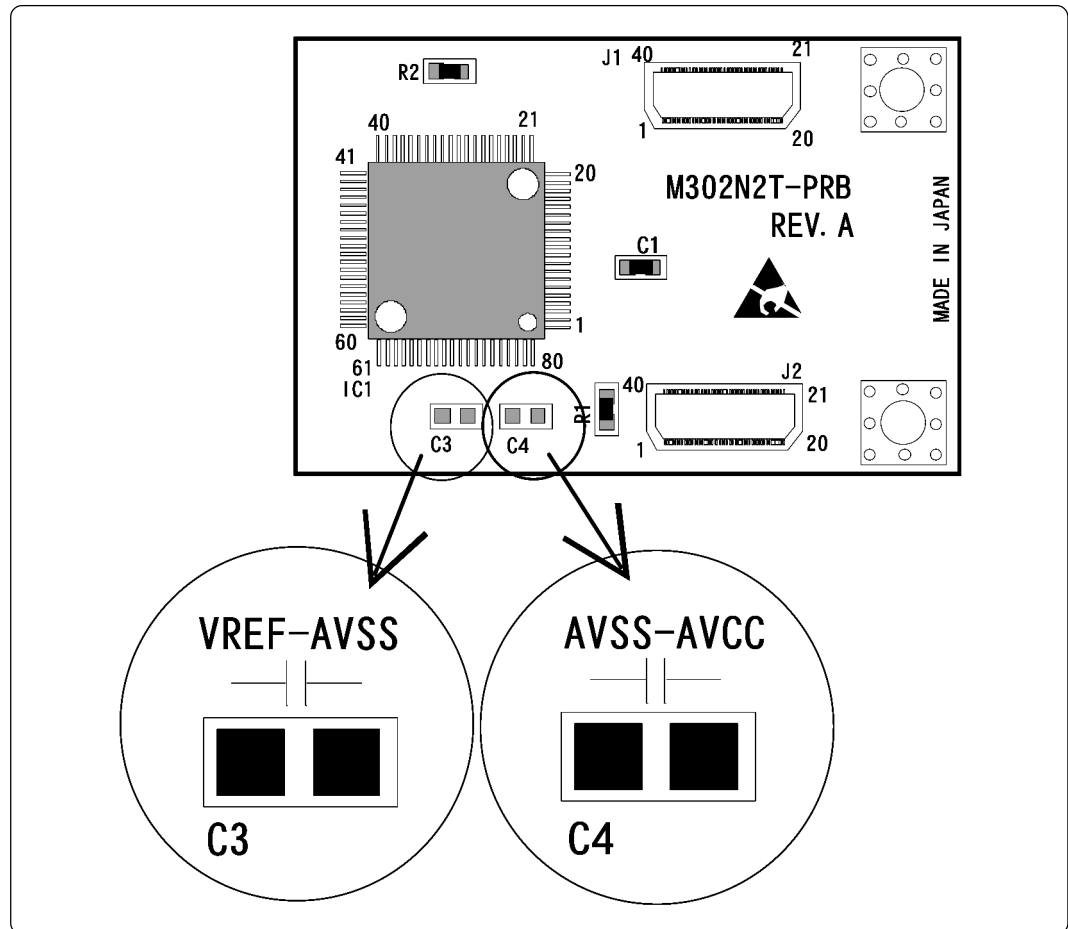

Figure 3.2 Foot patterns of A-D conversion bypass capacitor

IMPORTANT

Note on the Operation of A-D Converter:

- The characteristics of A-D converter differ from those of actual MCU because there are a flexible cable and other devices between the evaluation MCU and the target system. Make the final evaluation of the A-D converter with the actual MCU.

3.3 Connecting the M30200T-RPD-E

The emulation pod for M302N1 and M302N2 Group MCUs consists of the two products, the M30200T-RPD-E emulation pod and the M302N2T-PRB pod probe. Figures 3.3 and 3.4 show how to connect the M30200T-PRB and how to remove it, respectively.

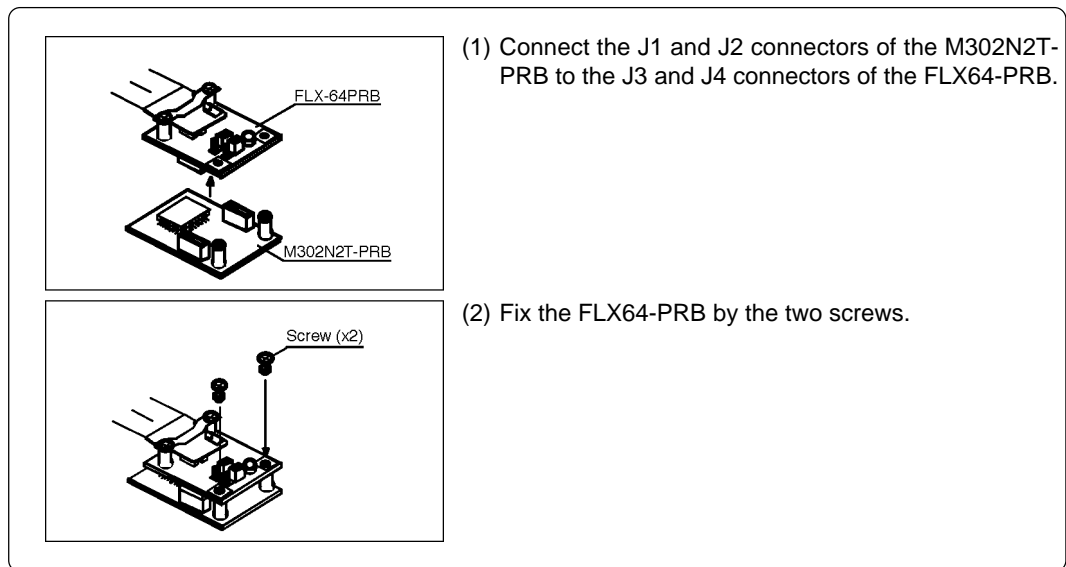

Figure 3.3 Connecting pod probe M302N2T-PRB

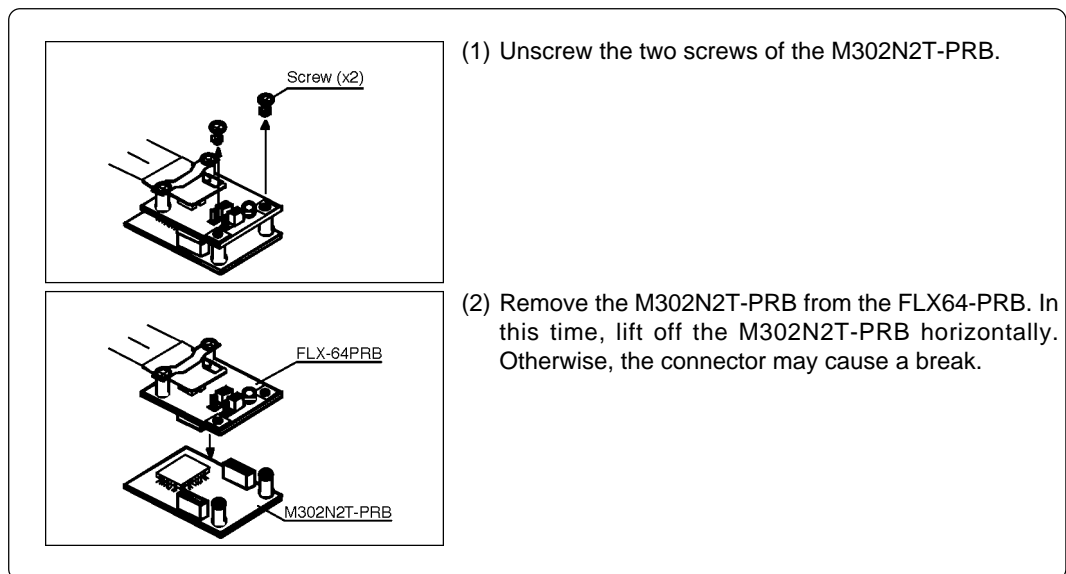

Figure 3.4 Removing pod probe M302N2T-PRB

CAUTION

When Connecting Pod Probe:

- Be sure to turn off the power before making connections. Otherwise, the internal circuits may be damaged.
- The small connectors of the FLX64-PRB (J3 and J4) and M302N2T-PRB (J1 and J2) are guaranteed for only 50 insertion/removal iterations.

3.4 Connecting the Target System

There are three ways available to connect this product to target systems as shown in Figure 3.5.

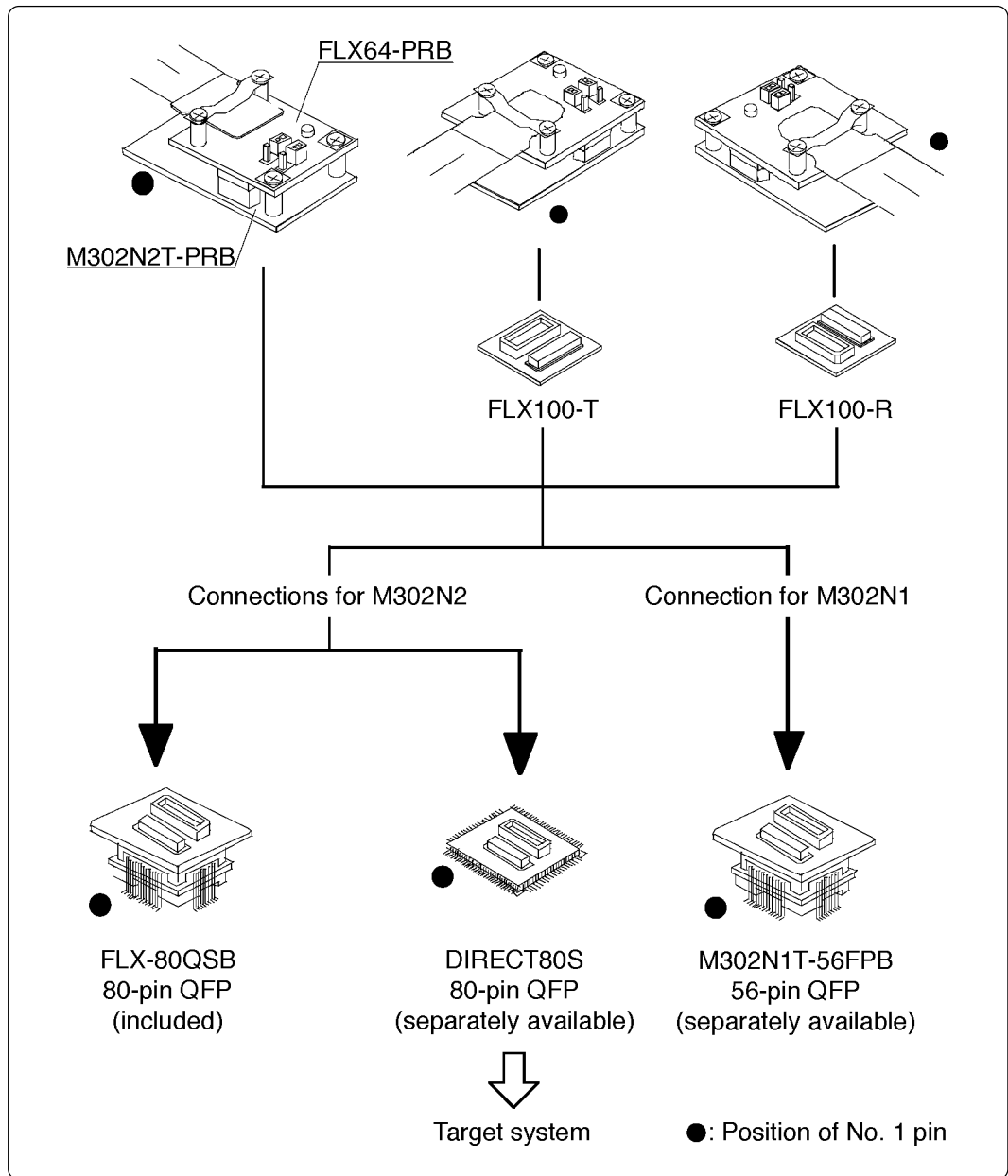

Figure 3.5 Connecting the target system

CAUTION

Notes on Connecting the Target System:

- Always shut OFF power before connecting the target system.
- The small connectors of the M302N2T-PRB (J3 and J4) are guaranteed for only 20 insertion/removal iterations.

The emulation pod for M302N2 Group needs the pitch converter board FLX-80QSB or DIRECT80S and the emulation pod for M302N1 Group needs the pitch converter board M302N1T-56FPB. Figures 3.6 and 3.7 show how to connect the pitch converter board FLX-80QSB for 80-pin QFP and how to connect the pitch converter board M302N1T-56FPB for 56-pin QFP, respectively.

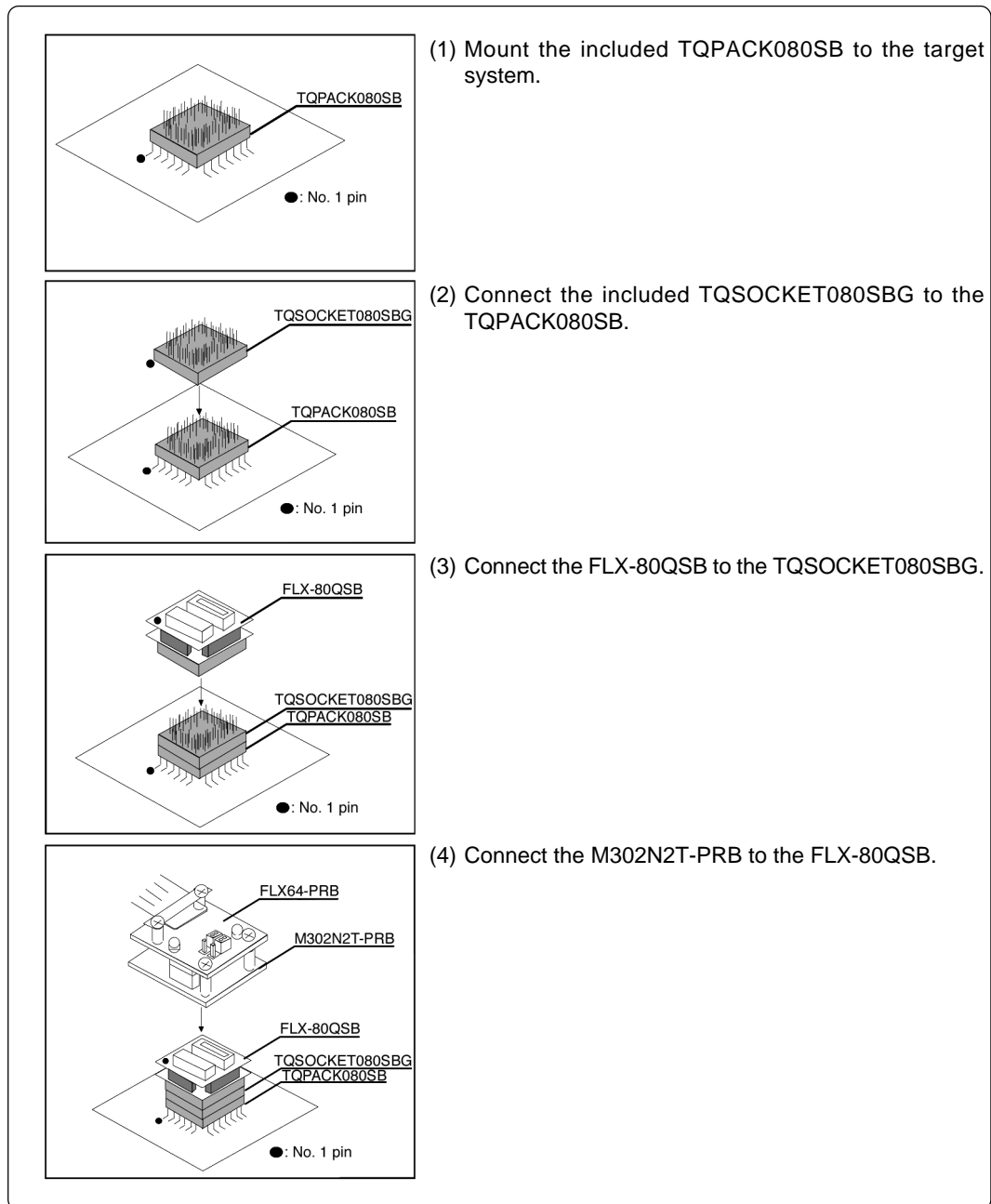

Figure 3.6 Connecting the pitch converter board FLX-80QSB for 80-pin QFP

⚠ CAUTION

Note on Connecting the Target System:

- Take care not to attach the pitch converter board to the socket in an inverted position.

Figure 3.7 shows how to connect the pitch converter board M302N1T-56FPB for 56-pin 0.65-mm-pitch QFP.

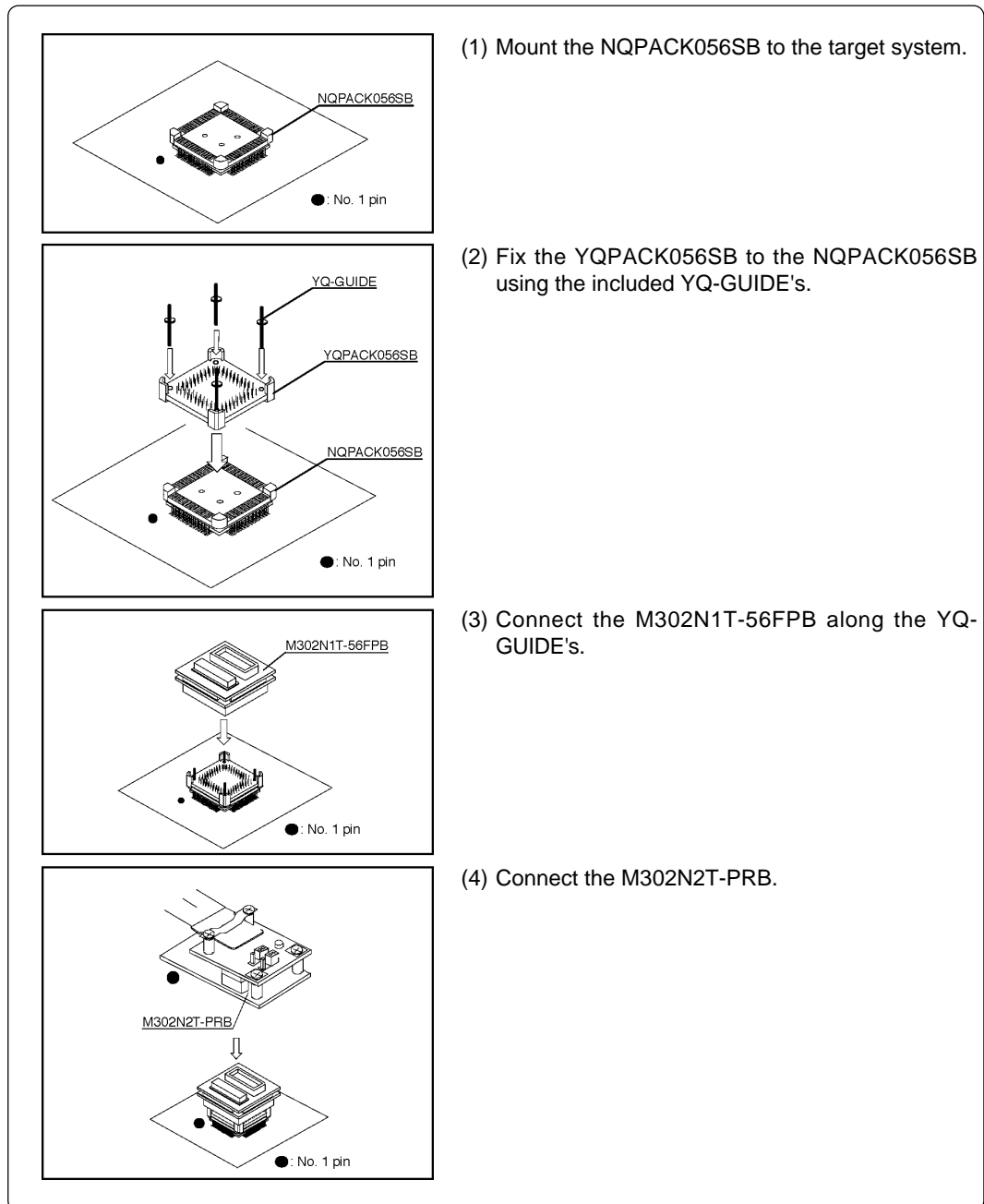

Figure 3.7 Connecting the pitch converter board M302N1T-56FPB for 56-pin QFP

⚠ CAUTION

Note on Connecting the Target System:

- Take care not to attach the pitch converter board to the socket in an inverted position.

3.5 Procedures for Making MCU File for M3T-PD30

It is necessary to change the contents of the MCU file according to the MCU to be developed. Make the MCU file M302N1.MCU for M302N1 Group and M302N2.MCU for M302N2 Group and store it in the following directory (the directory varies depending on the version of the M3T-PD30).

- M3T-PD30 Ver.5.00 or later: Store the MCU file in the "Mcufiles" folder in the directory same as emulator debugger M3T-PD30 is stored.
- M3T-PD30 Ver.4.10 or earlier: Store the MCU file in the folder same as emulator debugger M3T-PD30.

The contents of the MCU file (the SFR area, internal RAM area, internal ROM area, the name of firmware file) are shown below. Change the settings according to the MCU to be debugged. Use your text editor for changing the MCU file. The parts listed in boldface with an underline are to be changed.

The contents of the MCU file are as follows:

(1) For M302N2FCTGP (M302N2.MCU)

0	: SFR area	Start address
3FF	:	End address
400	: Internal RAM	Start address
<u>17FF</u>	:	End address
<u>E0000</u>	: Internal ROM	Start address
FFFFF	:	End address
M30620B	: Name of firmware (Do not change.)	
0	: Expansion No.	M3T-PD30 V.4.00 or later required (Do not change.)

(2) For M302N1M4T-xxxFP (M30217.MCU)

0	: SFR area	Start address
3FF	:	End address
400	: Internal RAM	Start address
<u>BFF</u>	:	End address
<u>E8000</u>	: Internal ROM	Start address
FFFFF	:	End address
M30620B	: Name of firmware (Do not change.)	
0	: Expansion No.	M3T-PD30 V.4.00 or later required (Do not change.)

Chapter 4. Specifications

This chapter describes specifications of this product.

4.1 Specifications	26
4.2 External Dimensions	27
(1) External Dimensions of Pod Probe	27
(2) External Dimensions of Converter Board (FLX-80QSB)	27
(3) External Dimensions of Converter Board (M302N1T-56FPB)	28

Chapter 4. Specifications

4.1 Specifications

Table 4.1 lists the specifications of the M302N2T-PRB.

Table 4.1 Specifications of M302N2T-PRB

Emulator	PC4701
Emulation pod main unit	M30200T-RPD-E
Applicable MCUs	M302N1 and M302N2 Group MCUs
Usable MCU mode	Single-chip mode
Emulation memory	1 MB
Max. operating frequency	$X_{IN} = 10.0$ MHz (no-wait, 4.2 - 5.5 V)
Operating power voltage	4.2 - 5.5 V
Stack capacity for the emulator	Max. 8 bytes
Suspended cycles in run-time debug	16-byte dump: approx. 312 BCLK cycle 16-byte fill: approx. 283 BCLK cycle
Power supply to emulation pod	1. Supplied from the emulator main unit 2. The operating voltage of the emulation pod main unit is determined by detecting the supply voltage of the target system. When no target system is connected, or when the supply voltage of the target system is more than 5.0 V, the operating voltage is 5.0 V.
Operating temperature range	5 to 35°C (no dew)
Storage temperature range	-10 to 60°C (no dew)
Connection to the target system See "3.4 Connecting the Target System" (page 21).	M302N2 Group: for 80-pin 0.65-mm-pitch QFP (80P6S-A) FLX-80QSB (included) or DIRECT80S (not included) M302N1 Group: for 56-pin 0.65-mm-pitch QFP (56P6S-A) M302N1T-56FPB (not included)

4.2 External Dimensions

(1) External Dimensions of Pod Probe

Figure 4.1 shows the external dimensions of the pod probe M302N2T-PRB.

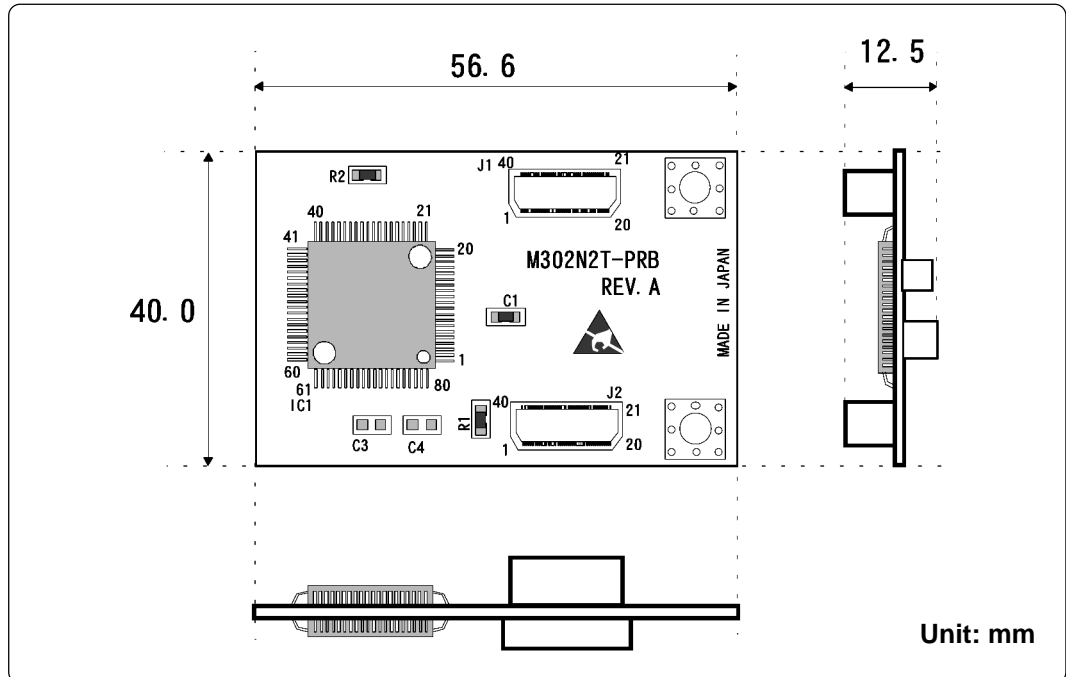

Figure 4.1 External dimensions of the pod probe M302N2T-PRB

(2) External Dimensions of Converter Board (FLX-80QSB)

Figure 4.2 shows the external dimensions and a sample foot pattern of the pitch converter board FLX-80QSB for 80-pin 0.65-mm-pitch QFP.

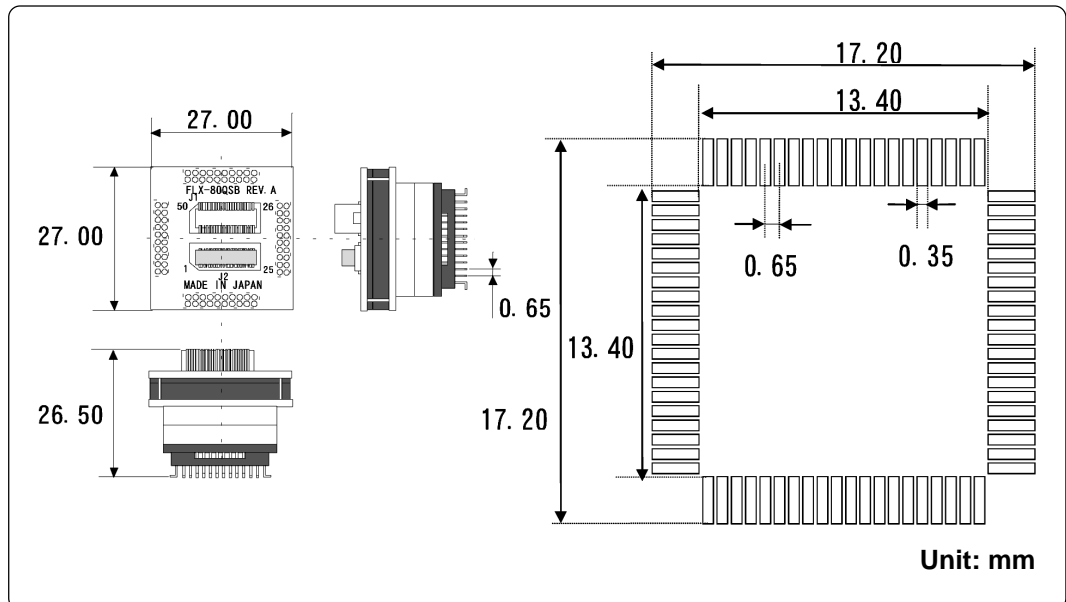

Figure 4.2 External dimensions of the FLX-80QSB

(3) External Dimensions of Converter Board (M302N1T-56FPB)

Figure 4.3 shows the external dimensions and a sample foot pattern of the pitch converter board M302N1T-56FPB for 56-pin 0.65-mm-pitch QFP.

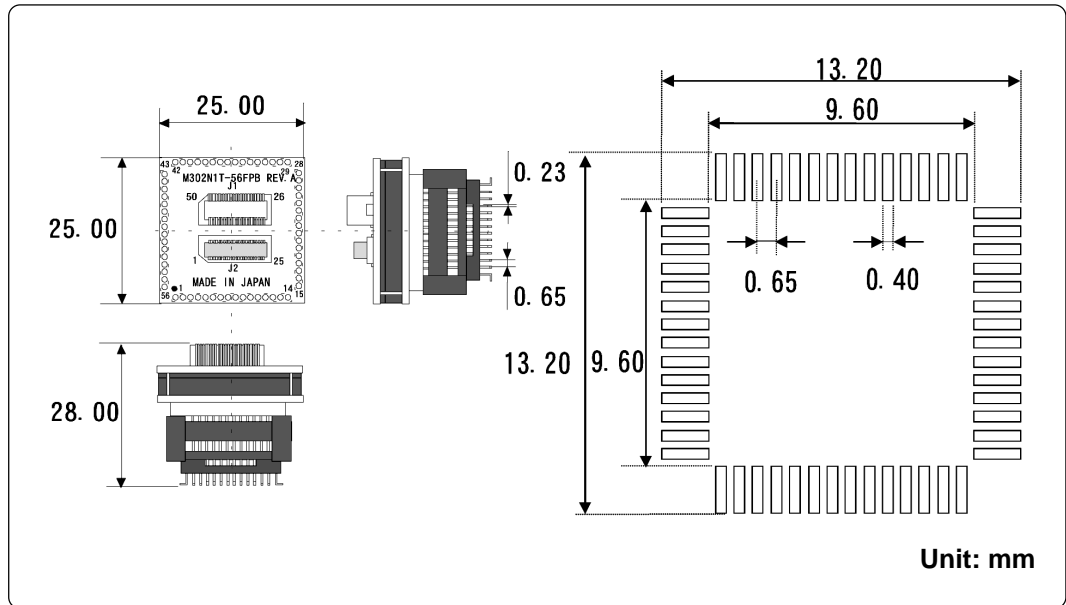

Figure 4.3 External dimensions of the M302N1T-56FPB

Chapter 5. Troubleshooting

This chapter describes how to troubleshoot when this product does not work properly.

5.1 When the Emulator Debugger Does Not Start Up Properly	30
(1) When the LED Display of PC4701 is Abnormal	30
(2) Errors Occur When Starting Up the Emulator Debugger (When the target system is connected)	31
(3) Errors Occur When Starting Up the Emulator Debugger (When the target system is not connected)	32
5.2 Operation Differs from That of Actual MCUs	32

Chapter 5. Troubleshooting

When this product does not work properly, check the following.

5.1 When the Emulator Debugger Does Not Start Up Properly

(1) When the LED Display of PC4701 is Abnormal

Table 5.1 LED's abnormal display and its checkpoints

Error	Connection to the target system	Checkpoint
LEDs do not light up.	-	Recheck the power cable is connected to the PC4701. <i>See the PC4701 User's Manual.</i>
All LEDs remain lit.	-	(1) Recheck the connection between the M30200T-RPD-E and this product. <i>See "3.3 Connecting the M30200T-RPD-E" (page 20).</i> (2) Recheck the connection between the PC4701 and the M30200T-RPD-E. <i>See the M30200T-RPD-E User's Manual.</i>
The POWER LED of "STATUS OF TARGET" does not light up.	Connected	Check power is properly supplied to the target system and that the target system is properly grounded.
The CLOCK LED of "STATUS OF TARGET" does not light up.	Disconnected	(1) Check that both the main and sub clocks of the emulator debugger are not set to "EXT". <i>See the CLK command of the emulator debugger.</i> (2) Check the oscillation circuit in the M30200T-RPD-E is oscillating. <i>See the M30200T-RPD-E User's Manual.</i>
	Connected	(1) Check the oscillation circuit in the target system is oscillating properly. (2) Check the switches of the FLX64-PRB are correctly set. <i>See "3.1 Switch Settings" (page 18).</i>
The RESET LED of "STATUS OF TARGET" does not go out.	Connected	Check if the reset pin of the target system is pulled up.

**(2) Errors Occur When Starting Up the Emulator Debugger
(When the target system is connected)**

Table 5.2 Checkpoints of errors when starting up the emulator debugger (target is connected)

Error	Checkpoint
Communication ERROR Data is not sent to the target	Check all emulator debugger settings, interface cable connections and switches on the rear of the PC4701 match. <i>See the user's manuals of the PC4701 and emulator debugger.</i>
Target system is not constructed properly	(1) Download the proper firmware. <i>See the user's manual of the emulator debugger.</i> (2) Recheck the connection between the M30200T-RPD-E and this product. <i>See "3.3 Connecting the M30200T-RPD-E" (page 20).</i> (3) Recheck the connection between the PC4701 and the M30200T-RPD-E. <i>See the M30200T-RPD-E User's Manual.</i>
The version of M3T-PD30 and the firmware on the target system are not same	Download the proper firmware. <i>See the user's manual of the emulator debugger.</i>
Target MCU is reset state	(1) Check the reset pin of the target system is pulled up. (2) Check the reset pin of the target system has changed from "L" to "H" level.
Target MCU cannot be reset	(1) If the reset circuit of the target system has a watchdog timer, disable the timer. (2) Check power is properly supplied to the target system and that the target system is properly grounded.
Target MCU is in "HOLD" state	The MCU is either in the stop mode or wait mode. Either reset the MCU or cancel the mode with an interrupt. <i>See MCU specifications.</i>
Target clock is stopped	(1) Check the oscillation circuit in the target system is oscillating properly. (2) Check the switches of the FLX64-PRB are correctly set. <i>See "3.1 Switch Settings" (page 18).</i>
Target MCU is not receiving power	Check power is properly supplied to the target system and that the target system is properly grounded.

(3) Errors Occur When Starting Up the Emulator Debugger (When the target system is not connected)

Table 5.3 Checkpoints of errors when starting up emulator debugger (target is not connected)

Error	Checkpoint
Communication ERROR Data is not sent to the target	Check all emulator debugger settings, interface cable connections and switches on the rear of the PC4701 match. <i>See the user's manuals of the PC4701 and emulator debugger.</i>
Target system is not constructed properly	(1) Download the proper firmware. <i>See the user's manual of the emulator debugger.</i> (2) Recheck the connection between the M30200T-RPD-E and this product. <i>See "3.3 Connecting the M30200T-RPD-E" (page 20).</i> (3) Recheck the connection between the PC4701 and the M30200T-RPD-E. <i>See the M30200T-RPD-E User's Manual.</i>
The version of M3T-PD30 and the firmware on the target are not same	Download the proper firmware. <i>See the user's manual of the emulator debugger.</i>
Target MCU is in "HOLD" state	The MCU is either in the stop mode or wait mode. Either reset the MCU or cancel the mode with an interrupt. <i>See MCU specifications.</i>
Target clock is stopped	Check the switches of the FLX64-PRB are correctly set. <i>See "3.1 Switch Settings" (page 18).</i>

5.2 Operation Differs from That of Actual MCUs

Make note of the fact that the operation when using the emulation pod differs from that of actual MCUs as follows.

- (1) Initializing the internal resources of MCU at power-on
- (2) Internal memories (ROM and RAM) capacities, etc.

With this emulator system, "INT" (emulation memory ON) is the default for mapping areas other than the SFR area (addresses 000h - 3FFh). For this reason, the emulation memory can read and write in areas other than the SFR, internal RAM and internal ROM.

- (3) Oscillator circuit

- Make note of the fact that in the oscillator circuit where a resonator is connected between the X_{IN} and X_{OUT} pins, oscillation does not occur because a flexible cable, buffer IC and other devices are used between the evaluation MCU and the target system. It is same for sub-clock oscillator circuits (X_{CIN} and X_{COU}T).
- For note on when using the oscillator circuit on the target system, refer to "4.2 (2) Using target system's oscillator" (page 21).

- (4) X_{OUT} pin

The X_{OUT} pin is not assigned to the evaluation MCU used by this product. For this reason, the X_{OUT} pin of this product is open.

- (5) DBC, single-step and BRK instruction interrupt vector table addresses

It is possible to download to DBC, single-step and BRK instruction interrupt vector table addresses. However, because the emulator system uses these areas, data different from the expected value is read out.

- (6) A-D conversion

The characteristics of A-D converter differ from those of actual MCU because there are a flexible cable, pitch converter and other devices between the evaluation MCU and the target system. Make the final evaluation of the A-D converter with the actual MCU.

Chapter 6. Maintenance and Warranty

This chapter describes how to maintenance, repair provisions and how to request for repair.

6.1 Maintenance	34
6.2 Warranty	34
6.3 Repair Provisions.....	34
6.4 How to Request for Repair	35

Chapter 6. Maintenance and Guarantee

6.1 Maintenance

If dust or dirt collects on any equipment of your emulation system, wipe it off with a dry soft cloth. Do not use thinner or other solvents because these chemicals can cause the equipment's surface coating to separate.

6.2 Guarantee

If your product becomes faulty within twelve months after its purchase while being used under good conditions by observing "Precautions for Safety" described in Chapter 1 of this user's manual, we will repair or replace your faulty product free of charge. Note, however, that if your product's fault is raised by any one of the following causes, we will repair it or replace it with new one with extra-charge:

- Misuse, abuse, or use under extraordinary conditions
- Unauthorized repair, remodeling, maintenance, and so on
- Inadequate user's system or misuse of it
- Fires, earthquakes, and other unexpected disasters

In the above cases, contact your local distributor. If your product is being leased, consult the leasing company or the owner.

6.3 Repair Provisions

(1) Repair with extra-charge

The products elapsed more than twelve months after purchase can be repaired with extra-charge.

(2) Replacement with extra-charge

If your product's fault falls in any of the following categories, the fault will be corrected by replacing the entire product instead of repair, or you will be advised to purchase new one, depending on the severity of the fault.

- Faulty or broken mechanical portions
- Flaw, separation, or rust in coated or plated portions
- Flaw or cracks in plastic portions
- Faults or breakage caused by improper use or unauthorized repair or modification
- Heavily damaged electric circuits due to overvoltage, overcurrent or shorting of power supply
- Cracks in the printed circuit board or burnt-down patterns
- Wide range of faults that makes replacement less expensive than repair
- Unlocatable or unidentified faults

(3) Expiration of the repair period

When a period of twelve months elapses after the model was dropped from production, repairing products of the model may become impossible.

(4) Transportation fees at sending your product for repair

Please send your product to us for repair at your expense.

6.4 How to Request for Repair

If your product is found faulty, follow the procedure below to send your product for repair.

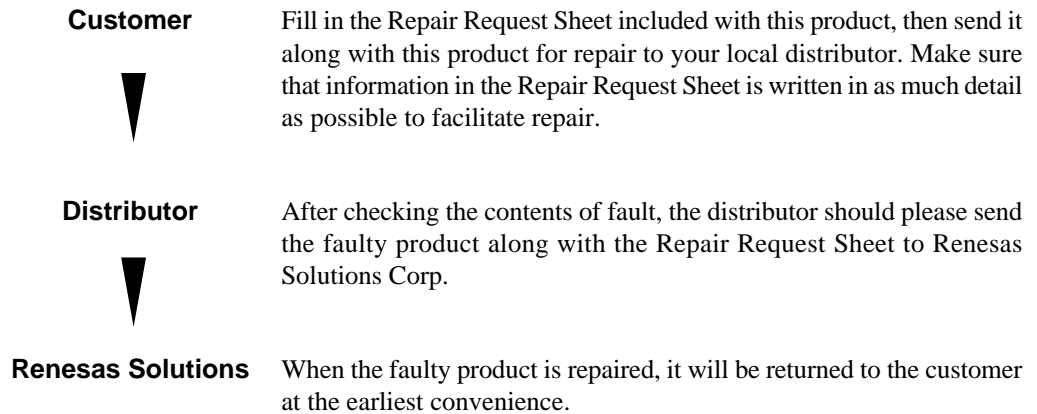

CAUTION

Note on Transporting the Product:



- When sending your product for repair, use the packing box and cushion material supplied with this product when delivered to you and specify handling caution for it to be handled as precision equipment. If packing of your product is not complete, it may be damaged during transportation. When you pack your product in a bag, make sure to use conductive polyvinyl supplied with this product (usually a blue bag). When you use other bags, they may cause a trouble on your product because of static electricity.

MEMO

M302N2T-PRB User's Manual

Rev.1.00
September 1, 2003
REJ10J0282-0100Z

COPYRIGHT ©2003 RENESAS TECHNOLOGY CORPORATION
AND RENESAS SOLUTIONS CORPORATION ALL RIGHTS RESERVED

M302N2T-PRB
User's Manual



Renesas Electronics Corporation

1753, Shimonumabe, Nakahara-ku, Kawasaki-shi, Kanagawa 211-8668 Japan

REJ10J0282-0100Z