

To our customers,

Old Company Name in Catalogs and Other Documents

On April 1st, 2010, NEC Electronics Corporation merged with Renesas Technology Corporation, and Renesas Electronics Corporation took over all the business of both companies. Therefore, although the old company name remains in this document, it is a valid Renesas Electronics document. We appreciate your understanding.

Renesas Electronics website: <http://www.renesas.com>

April 1st, 2010
Renesas Electronics Corporation

Issued by: Renesas Electronics Corporation (<http://www.renesas.com>)

Send any inquiries to <http://www.renesas.com/inquiry>.

Notice

1. All information included in this document is current as of the date this document is issued. Such information, however, is subject to change without any prior notice. Before purchasing or using any Renesas Electronics products listed herein, please confirm the latest product information with a Renesas Electronics sales office. Also, please pay regular and careful attention to additional and different information to be disclosed by Renesas Electronics such as that disclosed through our website.
2. Renesas Electronics does not assume any liability for infringement of patents, copyrights, or other intellectual property rights of third parties by or arising from the use of Renesas Electronics products or technical information described in this document. No license, express, implied or otherwise, is granted hereby under any patents, copyrights or other intellectual property rights of Renesas Electronics or others.
3. You should not alter, modify, copy, or otherwise misappropriate any Renesas Electronics product, whether in whole or in part.
4. Descriptions of circuits, software and other related information in this document are provided only to illustrate the operation of semiconductor products and application examples. You are fully responsible for the incorporation of these circuits, software, and information in the design of your equipment. Renesas Electronics assumes no responsibility for any losses incurred by you or third parties arising from the use of these circuits, software, or information.
5. When exporting the products or technology described in this document, you should comply with the applicable export control laws and regulations and follow the procedures required by such laws and regulations. You should not use Renesas Electronics products or the technology described in this document for any purpose relating to military applications or use by the military, including but not limited to the development of weapons of mass destruction. Renesas Electronics products and technology may not be used for or incorporated into any products or systems whose manufacture, use, or sale is prohibited under any applicable domestic or foreign laws or regulations.
6. Renesas Electronics has used reasonable care in preparing the information included in this document, but Renesas Electronics does not warrant that such information is error free. Renesas Electronics assumes no liability whatsoever for any damages incurred by you resulting from errors in or omissions from the information included herein.
7. Renesas Electronics products are classified according to the following three quality grades: “Standard”, “High Quality”, and “Specific”. The recommended applications for each Renesas Electronics product depends on the product’s quality grade, as indicated below. You must check the quality grade of each Renesas Electronics product before using it in a particular application. You may not use any Renesas Electronics product for any application categorized as “Specific” without the prior written consent of Renesas Electronics. Further, you may not use any Renesas Electronics product for any application for which it is not intended without the prior written consent of Renesas Electronics. Renesas Electronics shall not be in any way liable for any damages or losses incurred by you or third parties arising from the use of any Renesas Electronics product for an application categorized as “Specific” or for which the product is not intended where you have failed to obtain the prior written consent of Renesas Electronics. The quality grade of each Renesas Electronics product is “Standard” unless otherwise expressly specified in a Renesas Electronics data sheets or data books, etc.
 - “Standard”: Computers; office equipment; communications equipment; test and measurement equipment; audio and visual equipment; home electronic appliances; machine tools; personal electronic equipment; and industrial robots.
 - “High Quality”: Transportation equipment (automobiles, trains, ships, etc.); traffic control systems; anti-disaster systems; anti-crime systems; safety equipment; and medical equipment not specifically designed for life support.
 - “Specific”: Aircraft; aerospace equipment; submersible repeaters; nuclear reactor control systems; medical equipment or systems for life support (e.g. artificial life support devices or systems), surgical implantations, or healthcare intervention (e.g. excision, etc.), and any other applications or purposes that pose a direct threat to human life.
8. You should use the Renesas Electronics products described in this document within the range specified by Renesas Electronics, especially with respect to the maximum rating, operating supply voltage range, movement power voltage range, heat radiation characteristics, installation and other product characteristics. Renesas Electronics shall have no liability for malfunctions or damages arising out of the use of Renesas Electronics products beyond such specified ranges.
9. Although Renesas Electronics endeavors to improve the quality and reliability of its products, semiconductor products have specific characteristics such as the occurrence of failure at a certain rate and malfunctions under certain use conditions. Further, Renesas Electronics products are not subject to radiation resistance design. Please be sure to implement safety measures to guard them against the possibility of physical injury, and injury or damage caused by fire in the event of the failure of a Renesas Electronics product, such as safety design for hardware and software including but not limited to redundancy, fire control and malfunction prevention, appropriate treatment for aging degradation or any other appropriate measures. Because the evaluation of microcomputer software alone is very difficult, please evaluate the safety of the final products or system manufactured by you.
10. Please contact a Renesas Electronics sales office for details as to environmental matters such as the environmental compatibility of each Renesas Electronics product. Please use Renesas Electronics products in compliance with all applicable laws and regulations that regulate the inclusion or use of controlled substances, including without limitation, the EU RoHS Directive. Renesas Electronics assumes no liability for damages or losses occurring as a result of your noncompliance with applicable laws and regulations.
11. This document may not be reproduced or duplicated, in any form, in whole or in part, without prior written consent of Renesas Electronics.
12. Please contact a Renesas Electronics sales office if you have any questions regarding the information contained in this document or Renesas Electronics products, or if you have any other inquiries.

(Note 1) “Renesas Electronics” as used in this document means Renesas Electronics Corporation and also includes its majority-owned subsidiaries.

(Note 2) “Renesas Electronics product(s)” means any product developed or manufactured by or for Renesas Electronics.

M306V0T-RPD-E

User's Manual

Emulation Pod for M16C/6V Group M306V0

* IBM and PC/AT are registered trademarks of International Business Machines Corporation.

Keep safety first in your circuit designs!

- Renesas Technology Corporation and Renesas Solutions Corporation put the maximum effort into making semiconductor products better and more reliable, but there is always the possibility that trouble may occur with them. Trouble with semiconductors may lead to personal injury, fire or property damage. Remember to give due consideration to safety when making your circuit designs, with appropriate measures such as (i) placement of substitutive, auxiliary circuits, (ii) use of nonflammable material or (iii) prevention against any malfunction or mishap.

Notes regarding these materials

- These materials are intended as a reference to assist our customers in the selection of the Renesas Technology product best suited to the customer's application; they do not convey any license under any intellectual property rights, or any other rights, belonging to Renesas Technology Corporation, Renesas Solutions Corporation or a third party.
- Renesas Technology Corporation and Renesas Solutions Corporation assume no responsibility for any damage, or infringement of any third-party's rights, originating in the use of any product data, diagrams, charts, programs, algorithms, or circuit application examples contained in these materials.
- All information contained in these materials, including product data, diagrams, charts, programs and algorithms represents information on products at the time of publication of these materials, and are subject to change by Renesas Technology Corporation and Renesas Solutions Corporation without notice due to product improvements or other reasons. It is therefore recommended that customers contact Renesas Technology Corporation, Renesas Solutions Corporation or an authorized Renesas Technology product distributor for the latest product information before purchasing a product listed herein. The information described here may contain technical inaccuracies or typographical errors. Renesas Technology Corporation and Renesas Solutions Corporation assume no responsibility for any damage, liability, or other loss rising from these inaccuracies or errors. Please also pay attention to information published by Renesas Technology Corporation and Renesas Solutions Corporation by various means, including the Renesas home page (<http://www.renesas.com>).
- When using any or all of the information contained in these materials, including product data, diagrams, charts, programs, and algorithms, please be sure to evaluate all information as a total system before making a final decision on the applicability of the information and products. Renesas Technology Corporation and Renesas Solutions Corporation assume no responsibility for any damage, liability or other loss resulting from the information contained herein.
- Renesas Technology semiconductors are not designed or manufactured for use in a device or system that is used under circumstances in which human life is potentially at stake. Please contact Renesas Technology Corporation, Renesas Solutions Corporation or an authorized Renesas Technology product distributor when considering the use of a product contained herein for any specific purposes, such as apparatus or systems for transportation, vehicular, medical, aerospace, nuclear, or undersea repeater use.
- The prior written approval of Renesas Technology Corporation and Renesas Solutions Corporation is necessary to reprint or reproduce in whole or in part these materials.
- If these products or technologies are subject to the Japanese export control restrictions, they must be exported under a license from the Japanese government and cannot be imported into a country other than the approved destination. Any diversion or reexport contrary to the export control laws and regulations of Japan and/or the country of destination is prohibited.
- Please contact Renesas Technology Corporation or Renesas Solutions Corporation for further details on these materials or the products contained therein.

Precautions to be taken when using this product

- This product is a development supporting unit for use in your program development and evaluation stages. In mass-producing your program you have finished developing, be sure to make a judgment on your own risk that it can be put to practical use by performing integration test, evaluation, or some experiment else.
- In no event shall Renesas Solutions Corporation be liable for any consequence arising from the use of this product.
- Renesas Solutions Corporation strives to renovate or provide a workaround for product malfunction at some charge or without charge. However, this does not necessarily mean that Renesas Solutions Corporation guarantees the renovation or the provision under any circumstances.
- This product has been developed by assuming its use for program development and evaluation in laboratories. Therefore, it does not fall under the application of Electrical Appliance and Material Safety Law and protection against electromagnetic interference when used in Japan.
- Do not attempt to modify this equipment. If modified, your authority to operate this equipment might be voided by FCC.
Note: This equipment has been tested and found to comply with the limits for a Class A digital device, pursuant to part 15 of the FCC Rules. These limits are designed to provide reasonable protection against harmful interference when the equipment is operated in a commercial environment. This equipment generates, uses, and can radiate radio frequency energy and, if not installed and used in accordance with the user's manual, may cause harmful interference to radio communications. Operation of this equipment in a residential area is likely to cause harmful interference in which case the user will be required to correct the interference at his own expense.
Warning: This is a Class A product. In a domestic environment this product may cause radio interference in which case the user may be required to take adequate measures.

For inquiries about the contents of this document or product, fill in the text file the installer of the emulator debugger generates in the following directory and email to your local distributor.

\\SUPPORT\Product-name\SUPPORT.TXT

Renesas Tools Homepage <http://www.renesas.com/en/tools>

Preface

The M306V0T-RPD-E is an emulation pod for the M16C/6V group of Renesas 16-bit MCUs. The M306V0T-RPD-E is used by being connected to the PC4701 emulator (PC4701HS, PC4701L, PC4700H or PC4700L) and is controlled by the emulator debugger.

This manual mainly explains specifications and setting up of the M306V0T-RPD-E. For detail information about the PC4701 emulator and the emulator debugger, refer to each user's manual.

To check the components of this product, refer to "Things to Check When Unpacking" in this manual. If there is any question or doubt about this product, contact your local distributor.

To use the product properly

Precautions for Safety



- In both this user's manual and on the product itself, several icons are used to insure proper handling of this product and also to prevent injuries to you or other persons, or damage to your properties.
- The icons' graphic images and meanings are given in "Chapter 1. Precautions for Safety". Be sure to read this chapter before using the product.

When using outside Japan



- When using in Europe, the United States, or Canada, be sure to use both the emulator and the emulation pod which meet local standards. EMI standards are not met when this product is used with the PC4700H or PC4700L emulator.

Contents

Terminology	6
Things to Check When Unpacking	7
Chapter 1. Precautions for Safety	8
1.1 Safety Symbols and Meanings	8
1.2 Precautions for Safety	9
Warning Warning for Installation	9
Warning for Use Environment	9
Caution Cautions to Be Taken for This Product	9
Caution for Installation	9
Important Notes on PC4701 Emulators	10
Notes on Abnormal Operation	10
Notes on Target System	10
Notes on Connecting Target System	11
Note on Reset Input from Target System	11
Note on HOLD Input from Target System	11
Note on Address 0 Access	11
Notes on Differences between Actual MCU and Emulator	12
Notes on MAP Settings and References	14
Note on Changing Data in OSD RAM Area When Program is not Executed	14
Note on Reading MCU Internal Sources	15
Note on Stack	15
Chapter 2. Introduction	16
Chapter 3. Specifications	17
Chapter 4. Settings for Target Systems	18
4.1 Positions of Switches	18
4.2 Settings	19
4.3 Procedure for Setting Oscillation Frequency	20
4.4 Data Slicer I/O Signals and OSD Clock I/O Signal Circuits	23
4.5 Procedure for Setting Switches	25
4.6 Procedure for Writing MCU File	25

Chapter 5. Method of Connection	26
5.1 Connecting Emulator Main Unit	26
5.2 Connecting Target System	28
Chapter 6. Constraints	29
Chapter 7. Operation Timing (Memory Expansion and Microprocessor Modes).....	30
7.1 Separate Bus (no wait)	30
7.2 Separate Bus (with wait), When Accessing to External Memory Area	32
7.3 Multiplex Bus (with wait), When Accessing to External Memory Area	34
7.4 Timing Requirements	37
Chapter 8. Electrical Characteristics	39
Chapter 9. Maintenance and Guarantee	40
9.1 Maintenance	40
9.2 Guarantee	40
9.3 Repair Provisions	40
9.4 How to Request for Repair	41
Chapter 10. Troubleshooting	42
10.1 When M306V0T-RPD-E Does Not Work Properly	42
Appendix A. External Dimensions	43
A.1 External Dimensions of the M306V0T-RPD-E	43
A.2 External Dimensions of the FLX-100LCC	44
Appendix B. Connection Diagrams	45

Terminology

Some specific words used in this User's Manual are defined as follows:

PC4701

This means the generic name of the PC4701HS, PC4701L, PC4700H, and PC4700L emulators.

PC4701 system

This means an emulator system built around a PC4701 emulator. The PC4701 emulator system is configured with the emulator main unit, an emulation pod, an emulator debugger, and a host machine.

Emulator debugger

This means a software tool to control the emulator from the host machine through an interface.

Emulator debugger: M3T-PD30 (V.3.00 Release 1 or later)

Host machine: IBM PC/AT or compatible

OS: Windows 95 or Windows NT 4.0

CPU: 486DX4-100 MHz or Pentium 75 MHz (or faster recommended)

Memory: 16 MB or more

Target MCU

This means the microcomputer you are going to debug.

Target system

This means a user's application system using the microcomputer to be debugged.

Things to Check When Unpacking

The M306V0T-RPD-E consists of the following parts and manuals. When unpacking, check to see if your M306V0T-RPD-E package contains all of these items.

M306V0T-RPD-E (Emulation pod)	1
FLX120-RPD (Flexible cable for connecting PC4701 emulator)	1
Screws for connecting PC4701 emulator	2
FLX100 (Flexible cable for connecting target system, already connected)	1
FLX-100LCC (Converter board for 100LCC package)	1
OSC-2 (Oscillator board)	1
M306V0T-RPD-E English user's manual (this manual)	1
M306V0T-RPD-E Japanese user's manual	1

If any of these items are missing or found faulty, please contact your local distributor. Also, if there is any question or doubt about the packaged products, contact your local distributor.

CAUTION



Please keep the M306V0T-RPD-E's packing box and cushion material in your place for reuse at a later time when sending your product for repair or other purposes. Always use these packing box and cushion material when transporting the M306V0T-RPD-E.

Chapter 1. Precautions for Safety

In both the user's manual and on the product itself, several icons are used to insure proper handling of this product and also to prevent injuries to you or other persons, or damage to your properties.

This chapter describes the precautions which should be taken in order to use this product safely and properly. Be sure to read this chapter before using this product.

1.1 Safety Symbols and Meanings

	WARNING	If the requirements shown in the "WARNING" sentences are ignored, the equipment may cause serious personal injury or death.
	CAUTION	If the requirements shown in the "CAUTION" sentences are ignored, the equipment may malfunction.
	IMPORTANT	It means important information on using this product.

In addition to the three above, the following are also used as appropriate.

△ means WARNING or CAUTION.
Example:  **CAUTION AGAINST AN ELECTRIC SHOCK**

⊘ means PROHIBITION.
Example:  **DISASSEMBLY PROHIBITED**

● means A FORCIBLE ACTION.
Example:  **UNPLUG THE POWER CABLE FROM THE RECEPTACLE.**

The following pages describe the symbols "WARNING", "CAUTION", and "IMPORTANT".

1.2 Precautions for Safety

WARNING

Warning for Installation:



- Do not set this product in water or areas of high humidity. Spilling water or some other liquid into the main unit can cause an unreparable damage.

Warning for Use Environment:

- This equipment is to be used in an environment with a maximum ambient temperature of 35°C. Care should be taken that this temperature is not exceeded.

CAUTION

Cautions to Be Taken for This Product:



- Do not disassemble or modify this product as personal. Disassembling or modifying this product can cause damage.
- Use caution when handling the main unit. Be careful not to apply a mechanical shock.
- Do not touch directly the connector pins of the emulator main unit or the target MCU connector pins with your hand.
- Do not pull the emulation pod main unit by the FLX120-RPD flexible cable or the FLX100 flexible cable for connecting the target system.
- The flexible cables FLX120-RPD and FLX100 are different from earlier models. The slits make them more flexible. However, excessive flexing or force may break conductors.
- Do not use inch-size screws for this equipment. The screws used in this equipment are all ISO (meter-size) type screws. When replacing screws, use same type screws as used on the equipment.

Cautions for Installation:



- Do not place the main unit on its side when in use.

IMPORTANT

Notes on PC4701 Emulators:

- The PC4700H emulators whose serial number ends with a number cannot be used with M306V0T-RPD-E. Use only products whose serial number ends with a letter of the alphabet. The serial number is on the bottom of the PC4700H.

Example: 5KE100 Can NOT be used with M306V0T-RPD-E.
Requires an upgrade.

Example: 5LE123B Can be used with M306V0T-RPD-E.

- Do not turn off the power when downloading firmware. If the emulator is powered off in the middle of the process, it will become unable to start up normally. In cases when the power is inadvertently shut off, re-execute downloading.

Notes on Abnormal Operation:

- If the PC4701 system does not pass all self-checks (excluding when an target system error occurs), there is the possibility of trouble in the system. In such case, contact the place of purchase.

Please take note that self-check should be executed under the following conditions.

- (1) The target system is not connected.
 - (2) The Switch SW6 is set to 'L' position, SW7 to '16' (see Chapter 4).
- If the emulator malfunctions due to external interference or some other causes, follow the steps given below.
 - (1) Press the system reset switch located on the front panel of the emulator.
 - (2) If the emulator does not return to the normal operation despite the step (1) above, turn off the power source of the emulator, turn it on again.

Notes on Target System:

- Because the emulation pod does not have the capacity to supply power to other devices, design your system so that the emulator MCU is powered by the target system.
- Make sure that the target's supply voltage is within the MCU specification and in the range of +4.5 to 5.5 V.
- Do not change power supply voltage of the target system after activating the power.
- Before turning on power to anything, check the host machine, emulator main unit, emulation pod, conversion board and user's target system are properly connected. Activate power to units as explained here following.
 - (1) Turn on and off power to the target system, and then the PC4701 continuously.
 - (2) After turning on power to the PC4701, check the Target Status LEDs on the emulator' front panel to see if the M306V0T-RPD-E is ready to operate.
 - Is the power supplied? Check that Target Status LED (POWER) is on.
 - Is the reset released? Check that Target Status LED (RESET) is off.

IMPORTANT

Notes on Connecting Target System:

- When connecting the FLX100 flexible cable and the converter board, be careful not to forcibly press the connector top of the converter board. (The flexible cable and the converter board are guaranteed for only 20 insertion/removal iterations.)
- Especially be careful not to insert the converter board in the wrong direction.

Note on Reset Input from Target System:

- The reset input from the target system is accepted only during program execution (while the RUN signal lamp on the PC4701 is lit).

Note on HOLD Input from Target System:

- Input an 'L' level signal into the HOLD pin only during program execution. Doing so while the program is stopped or during run time debugging may cause the emulator to malfunction.

Note on Address 0 Access:

- With M16C/6V group MCUs, when a maskable interrupt is generated, the interrupt data (interrupt number and interrupt request level) stored in address 0 is read out.

Also, the interrupt request bit is cleared when address 0 is read out. Consequently, when the address 0 readout instruction is executed or when address 0 is read out in the cause of a program runaway, a malfunction occurs in that the interrupt is not executed despite the interrupt request, because the request bit of the highest priority interrupt factor enabled is cleared.

Therefore, with M306V0T-RPD-E, if address 0 is read out for anything other than interrupt processing, the yellow LED lights up as a warning. When this LED lights up, there is the possibility of illegal access to address 0, therefore check the program. This LED is extinguished from the emulator reset switch.

IMPORTANT

Notes on Differences between Actual MCU and Emulator:

- Emulator operation differs from mask MCU operation, as listed below:

- (1) Reset condition
- (2) Initial values of internal resource data at power-on
- (3) Internal RAM and ROM capacities, etc.
- (4) Ports P0₀ to P5₇

Of the M306V0T-RPD-E's I/O ports, ports P0₀ - P5₇ are connected to the user's target system through the port emulation circuit inside M306V0T-RPD-E.

Table 1.1 gives the device which uses these ports.

Table 1.1 I/O device used by each of the ports

Port	I/O device
P0 ₀ -P5 ₇	M60074-0111FP

- (5) Writing into pullup control registers 0 and 1 (addresses 03FC₁₆ and 03FD₁₆ respectively)

To write into pullup control registers 0 and 1 (addresses 03FC₁₆ and 03FD₁₆ respectively), it is necessary to write the word data from address 03FC₁₆. This is an M306V0T-RPD-E restriction.

- (6) Ports P5₀ - P5₃

To enable pullup when setting bit 2 (PUR12) of the pullup register 1 to '1' in single chip mode, be sure to set the bit 2 (PM02) and bit 7 (PM07) of the processor mode register 0 to '0'. This is an M306V0T-RPD-E restriction.

- (7) BCLK output disable

To disable the BCLK output, it is necessary to set the BCLK output disable bit (PM07) of processor mode register 0 (address 0004₁₆) to '1' and to set bit 3 of the port P5 direction register (address 03EB₁₆) to '0'. This is an M306V0T-RPD-E restriction.

- (8) Hold control

When an 'L' level signal is input to the terminal HOLD and the terminal enters the hold state, in actuality, ports P0₀ to P5₂ enter the hold state one half cycle later than the MCU (see Chapter 7, Operation Timing).

- (9) A/D converter

A/D converter characteristics differ from actual MCU characteristics because the flexible cable and other elements are used between the emulation MCU and user's target.

- (10) Status while the program is stopped

In a system using the PC4701, the loop iteration at the address F8000₁₆ establishes and maintains the status during program stop. Also, when debug commands are issued to check or edit memory data, addresses F8000₁₆ to F83FF₁₆ and addresses F6000₁₆ to F63FF₁₆ are used as work area. For this reason, when the CS0 output is enabled in the microprocessor mode, the CS0 signal is output.

IMPORTANT

(11) Actual MCU output and emulator output

Table 1.2 Actual MCU and emulator outputs

Access area	Signal	Actual MCU	M306V0T-RPD-E	Item with different outputs
SFR area	Address	Output	Output	
	Data	Output (Floating during read operations)	Floating	*
	RD/WR	Output (WR=Low at write cycle, RD=Low at read cycle)	No output (High output fixed)	*
	CS	No output (High output fixed)	No output (High output fixed)	
	ALE	No output (Low output fixed)	Output	*
	BHE	Output	Output	
Internal RAM area	Address	Previous status maintained	Output	*
Internal ROM area	Data	Floating	Floating	
	RD/WR	No output (High output fixed)	No output (High output fixed)	
	CS	No output (High output fixed)	No output (High output fixed)	
	ALE	No output (Low output fixed)	Output	*
	BHE	No output (Previous status maintained)	Output	*
External area	Address	Output	Output	
	Data	Output (Inputs external data when reading)	Output (Inputs external data when reading)	
	RD/WR	Output (WR=Low at write cycle, RD=Low at read cycle)	Output (WR=Low at write cycle, RD=Low at read cycle)	
	CS	Output	Output	
	ALE	Output	Output	
	BHE	Output	Output	
In STOP state	Address	/	Output	
	Data		Floating	
	RD/WR		Output only for Read operations (WR = High output fixed)	
	CS		Output	
	ALE		Output	
	BHE		Output	

IMPORTANT

Notes on MAP Settings and References:

- For details on MAP settings and references, refer to the M3T-PD30 emulator debugger user's manual.
- Always set the SFR area to EXTERNAL.
- Set the OSD RAM area to INTERNAL.
- This pod uses the 4 bytes from 0FFFC₁₆ to 0FFFF₁₆ as a stack area for a RESET command. The RESET command cannot be correctly executed when these 4 bytes cannot be read or written to. You must therefore take care using the MAP resetting procedure when the following condition (1) or condition (2) are true.

- (1) When the 4 bytes from 0FFFC₁₆ to 0FFFF₁₆ are set to EXTERNAL in a system shifting from single chip mode to memory expansion mode or microprocessor mode
- (2) When the 4 bytes from 0FFFC₁₆ to 0FFFF₁₆ are set to EXTERNAL in a system started in microprocessor mode and there is no read/write-enabled memory in the external area.

Use the following MAP setting procedure when either of the above conditions (1) or (2) are true.

- (1) Set the 4 bytes from bytes from 0FFFC₁₆ to 0FFFF₁₆ to INTERNAL.
- (2) Execute the M3T-PD30 emulator debugger RESET command.
- (3) Set the stack pointer.

(Example)

RESET:

FCLR I

LDC #480H, SP <- stack pointer setting

: (STOP the program after executing this command.)

- (4) Set the 4 bytes from 0FFFC₁₆ to 0FFFF₁₆ to EXTERNAL.

Note on Changing Data in OSD RAM Area When Program is not Executed:

- To change data when a program is not executed, write data when the map setting is in both 'INTERNAL' and 'EXTERNAL'.

Procedure

- (1) With 'INTERNAL' specified, change data in the OSD RAM area.
Change data in the MEMORY WINDOW, Script Window, etc.
- (2) From the script window, change the map setting of the OSD RAM area to 'EXTERNAL' .
MAP 400,FFF,EXT
- (3) With 'EXTERNAL' specified, change data in the OSD RAM area.
Change data in the MEMORY WINDOW, Script Window, etc.
- (4) Change the map setting of the OSD RAM area to 'INTERNAL' again.
MAP 400,FFF,INT

(Example) When changing the data in the OSD RAM area (Address: 410h) to '55h'.

set MemoryByte(MB) 410,55

MAP 400,FFF,EXT

set MemoryByte(MB) 410,55

MAP 400,FFF,INT

IMPORTANT

Note on Reading MCU Internal Sources:

- When this product is configured with the emulator debugger, the following results occur when reading the registers listed in Table 1.3. Data is not displayed correctly, but internal data is not affected at all.

(1) Real-time tracing

Data values in the MCU internal source read cycle are not displayed correctly.

(2) Real-time RAM monitoring

Data is not displayed correctly.

This happens because data read from the MCU internal source is not output to an external point. When data is written into an MCU internal source, the data input from the external point is displayed correctly.

Table 1.3 Registers and signals

Register	Signal
Processor mode registers 0, 1	PM0, PM1
System clock control registers 0, 1	CM0, CM1
Chip select control register	CSR
Address identity interrupt enable register	AIER
Protect register	PRCR
Supervisor timer start register	WDTS
Supervisor timer control register	WDC
Address identity interrupt registers 0, 1	RMAD0, RMAD1
DMA source pointers 0, 1	SAR0, SAR1
DMA destination pointers 0, 1	DAR0, DAR1
DMA transfer counters 0, 1	TCR0, TCR1
DMA control registers 0, 1	DM0CON, DM1CON

Note on Stack:

- This product uses up to 8 bytes for stack.

Chapter 2. Introduction

M306V0T-RPD-E is used by being connected to the PC4701 emulator main unit. Figure 2.1 shows the system configuration.

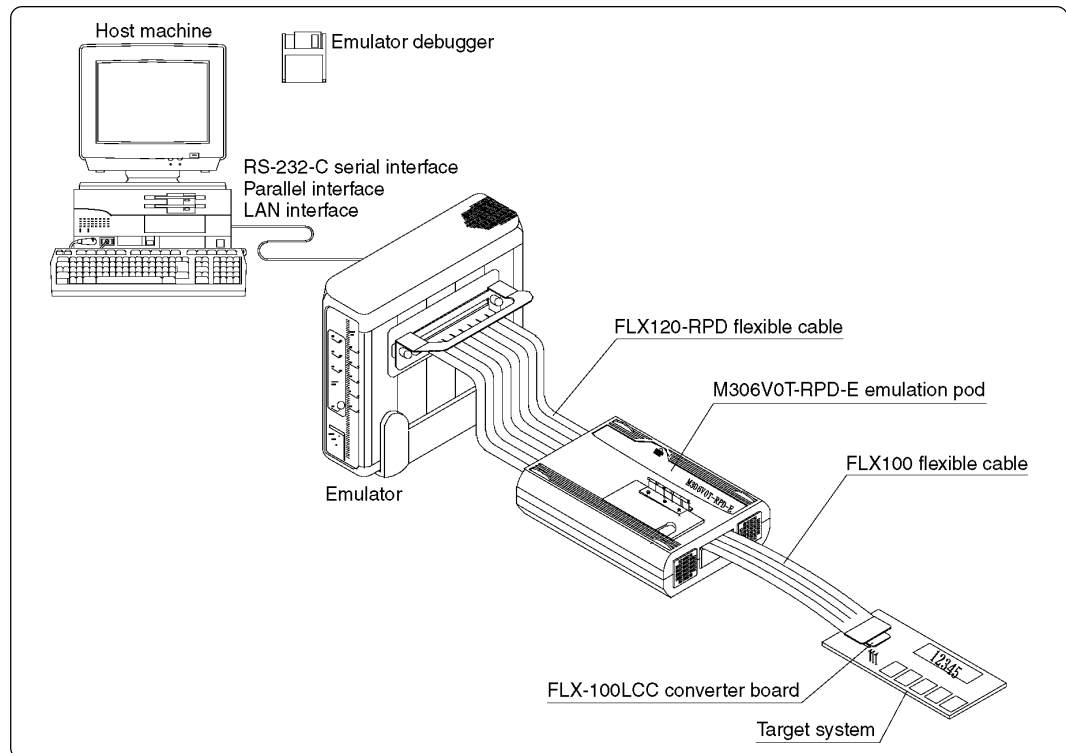

Figure 2.1 System configuration

Following products (1) to (4) are attached to M306V0T-RPD-E.

(1) Emulation pod (M306V0T-RPD-E)

This emulation pod contains emulation memory and debug functions.

(2) Flexible cable (FLX120-RPD)

This 120-pin flexible cable connects the PC4701 and the emulation pod.

(3) Flexible cable (FLX100)

This 100-pin flexible cable connects the emulation pod and the target system.

(4) Converter board (FLX-100LCC)

This board is connected to a socket for 100LCC on the target system.

Chapter 3. Specifications

Table 3.1 lists the specifications of the M306V0T-RPD-E.

Table 3.1 Specifications of the M306V0T-RPD-E

Item	Description
Usable emulator	PC4701HS, PC4701L
Usable MCU	M16C/6V Group MCUs
Usable MCU modes	(1) Single-chip mode (2) Memory expansion mode (3) Microprocessor mode
Evaluation MCU type	M306V0EEFP
Emulation pod clock	Main clock (Xin): 10.000 MHz Sub-clock (Xcin): 32.768 kHz
Max. operating frequency of emulation pod	10 MHz, 0-wait (Vcc = 5.0 V)
Power supply range	4.5 to 5.5 V
Emulation memory	1 MB
Stack capacity used for emulator	Up to 8 bytes
Suspended cycles in run-time debug	16-byte dump: About 312 BCLK cycle 16-byte fill: About 283 BCLK cycle
Power supply to pod	1. Supplied from an emulator 2. The operating voltage of the emulation pod is determined by detecting the supply voltage of the target system. When no target system is connected, or when the supply voltage of the target system is more than 5.0 V, the operating voltage is 5.0 V.
Connection with target system	100-pin LCC package: via FLX-100LCC
Operating temperature range	5 to 35°C (no dew)
Storage temperature range	-10 to 60°C
Overseas standards	<ul style="list-style-type: none"> • EMI standards (FCC part15 Class A) • CE marking (EN55022, EN50082-1)

Chapter 4. Settings for Target Systems

4.1 Positions of Switches

Figure 4.1 shows positions of switches on the M306V0T-RPD-E.

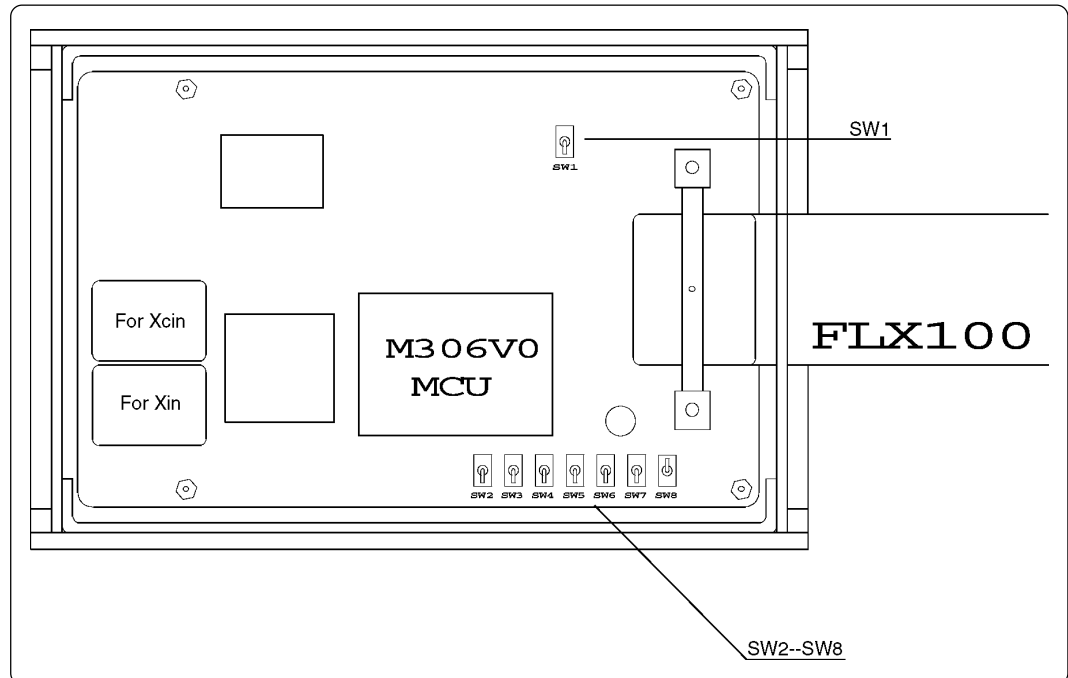





















Figure 4.1 Positions of switches

4.2 Settings

Table 4.1 gives a list of switch settings.

Table 4.1 Switch (SW) settings

Signal	SW No.	Setting		
PORT/OSD (P5 ₇)	SW1	To use port P5 ₇ PORT (P5 ₇)  OSD (Factory-setting)		To use OSD function PORT (P5₇)  OSD
P8 ₇ /XCIN	SW2	To use port P8 ₇ P8 ₇  XCIN (Factory-setting)		To use XCIN terminal P8 ₇  XCIN
P8 ₆ /XCOUT	SW3	To use port P8 ₆ P8 ₆  XCOUT (Factory-setting)	To leave unconnected P8 ₆  XCOUT	To use XCOUT terminal P8 ₆  XCOUT
XOUT	SW4	To open OPEN  XOUT (Factory-setting)		To connect XOUT terminal OPEN  XOUT
P5 ₅ /HOLD P5 ₇ /RDY	SW5	With pullup resistor (HOLD/RDY) H  OPEN (Factory-setting)		Without pullup resistor H  XOUT OPEN
CNV _{ss}	SW6	To pull down 33 kΩ L  H (Factory-setting)	To leave unconnected L  H	To pull up 33 kΩ L  H
BYTE	SW7	To pull down 33 kΩ 16  8 (Factory-setting)	To leave unconnected 16  8	To pull up 33 kΩ 16  8
P7 ₀ /7 ₁	SW8	With pullup resistor H  OPEN (Factory-setting)		Without pullup resistor H  OPEN (Factory-setting)

* Leave the SW1 in the PORT position.

IMPORTANT

Note on Switch Settings:

- Be sure to turn off the power before setting the switches. Otherwise, the internal circuits may be damaged.

4.3 Procedure for Setting Oscillation Frequency

If you are using the emulation pod's internal oscillator, see (1) below. If you are using the target system's oscillator, see (2) on page 22.

(1) Using emulation pod's oscillator

M306V0T-RPD-E is available with two types of internal oscillator circuits:

- OSC-3 oscillator board (preinstalled in M306V0T-RPD-E): 10 MHz
- OSC-2 oscillator board (bare board)

(a) OSC-3 oscillator board

M306V0T-RPD-E is equipped with a 10MHz internal oscillator board. If you are running M306V0T-RPD-E at 10 MHz, you can use the OSC-3 oscillator board shipped with.

(b) OSC-2 oscillator board

M306V0T-RPD-E is supplied with an oscillator circuit bare board (connector pin mounting).

If you are using M306V0T-RPD-E with internal oscillation frequencies other than those permitted by the standard OSC-3 oscillator board, create the desired oscillator circuit on the OSC-2 bare board and replace the OSC-3 board with the OSC-2 board.

Figure 4.2 shows the external dimensions and connector pin layout of the OSC-2 oscillator board. Figure 4.3 shows the OSC-2 circuit. Use the circuit constants recommended by the maker of the oscillator circuit.

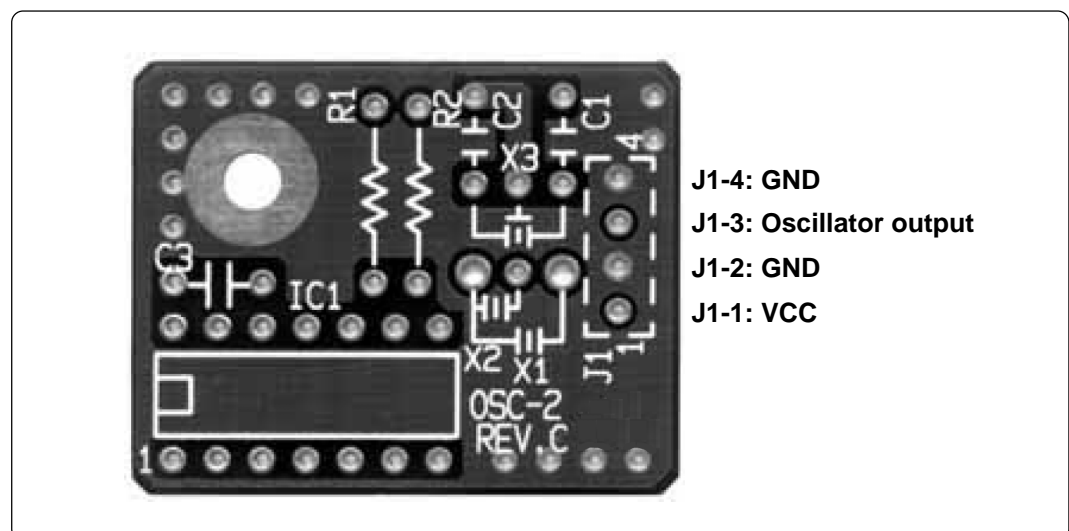

Figure 4.2 External view of oscillator bare board OSC-2 and connector pin assignments

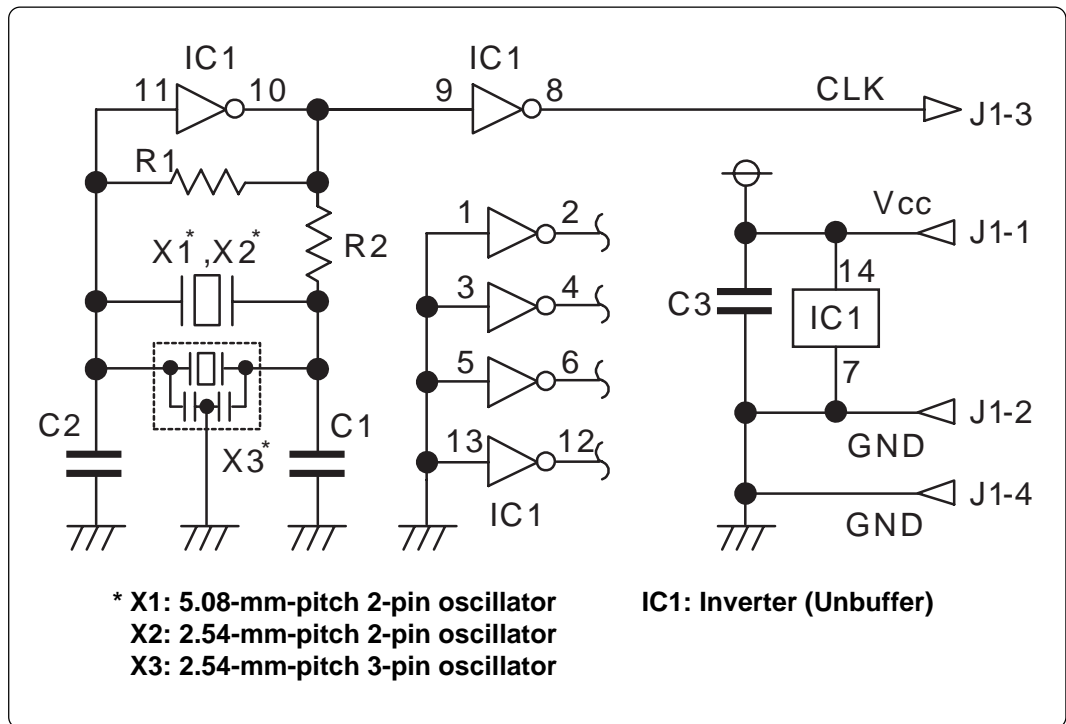

Figure 4.3 Circuit of oscillator board OSC-2

Figure 4.4 shows how to replace the oscillator board.

- (a) Remove the screw locking the oscillator board in place.
- (b) Lift the board directly up and out of the product.
- (c) Plug the J1 connector of the new oscillator board into the J7 connector on the M306V0T-RPD-E board.
- (d) Lock the board to the M306V0T-RPD-E board with the screw.

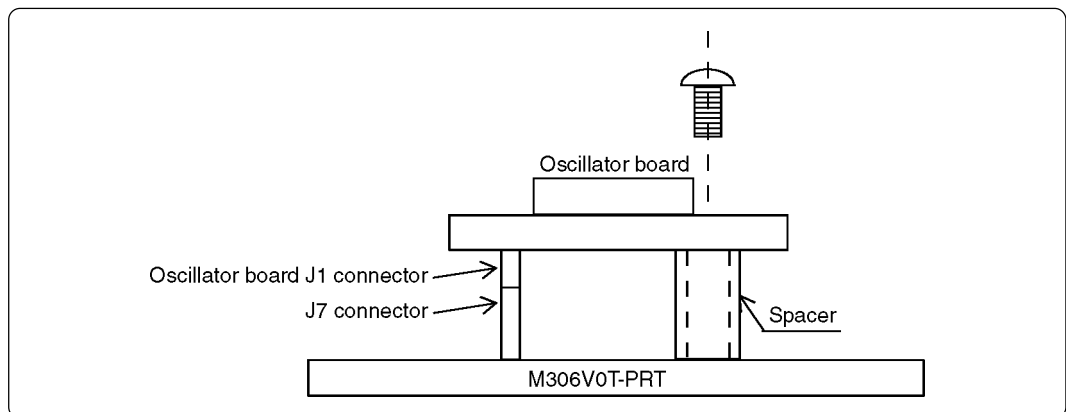

Figure 4.4 Replacing oscillator board

(2) Using target system's oscillator

- a. To operate the emulator with an external clock, construct the oscillation circuit shown in Figure 4.5 in the target system and input the oscillation output at 40-60% duty (within the operating range of the emulator's MCU) into the X_{in} (X_{cin}) pin.
- b. Make note of the fact that in the oscillation circuit shown in Figure 4.6 where a resonator is connected between the X_{in} (X_{cin}) and X_{out} (X_{cout}) pins, oscillation does not occur because a flexible cable, buffer IC and other devices are used between the evaluation MCU and the target system.
- c. Use the M3T-PD30 emulator debugger to set CLK to EXT. For details, see the M3T-PD30 emulator debugger user's manual.

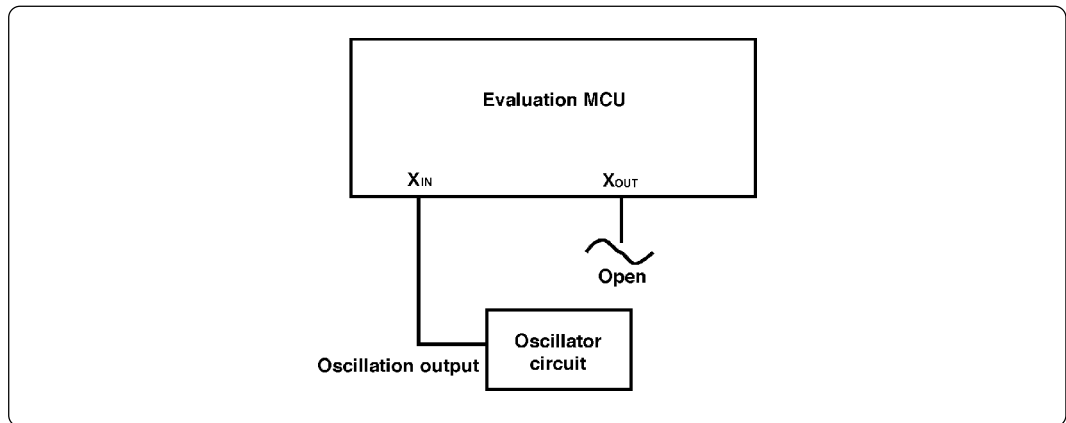

Figure 4.5 External oscillator circuit

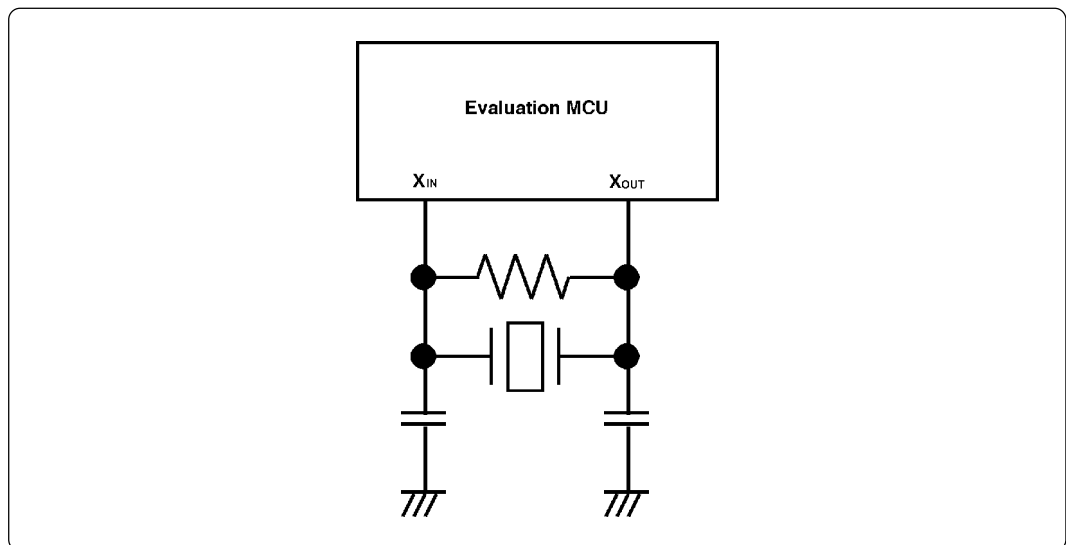

Figure 4.6 Circuit for no oscillation in this pod

4.4 Data Slicer I/O Signals and OSD Clock I/O Signal Circuits

Figure 4.7 shows the layout of the parts on the board and the circuit diagrams used for data slicing and the OSD clock circuits.

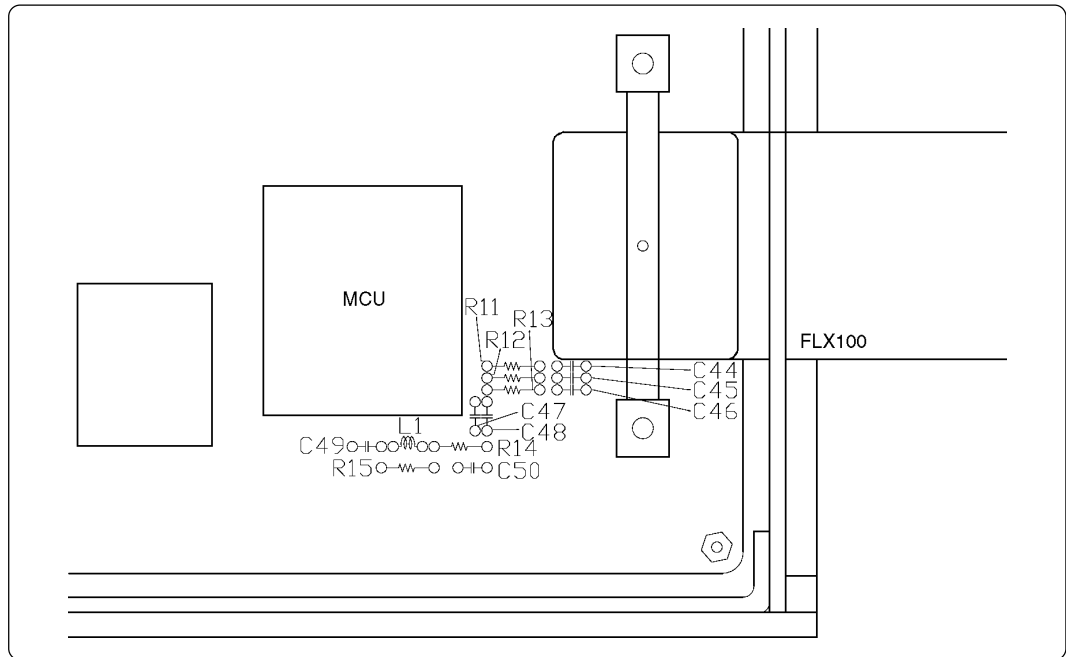

Figure 4.7 Layout of parts

(1) Figure 4.8 shows the part numbers and the constants of the parts of the signal CVIN.

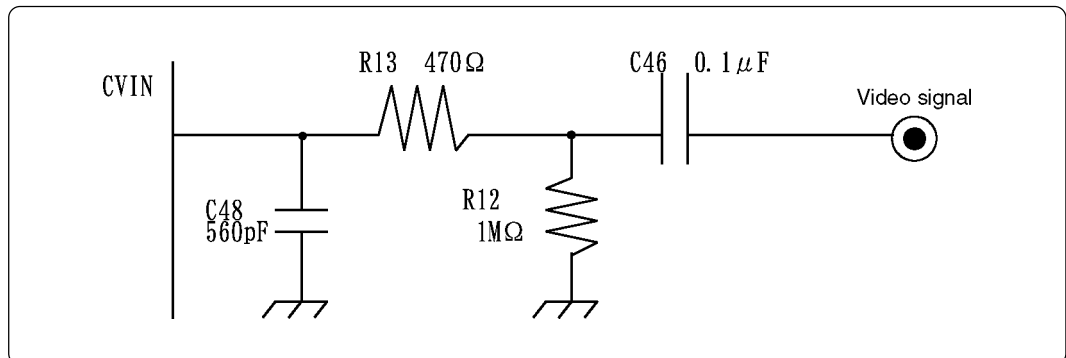

Figure 4.8 CVIN signal circuit

(2) Figure 4.9 shows the part numbers and the constants of the parts of the signal HLF.

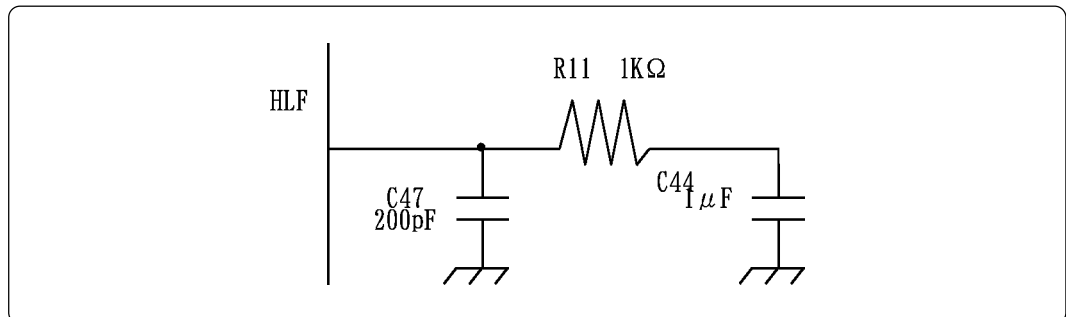

Figure 4.9 HLF signal circuit

(3) Figure 4.10 shows the part numbers and the constants of the parts of the signal VHOLD.

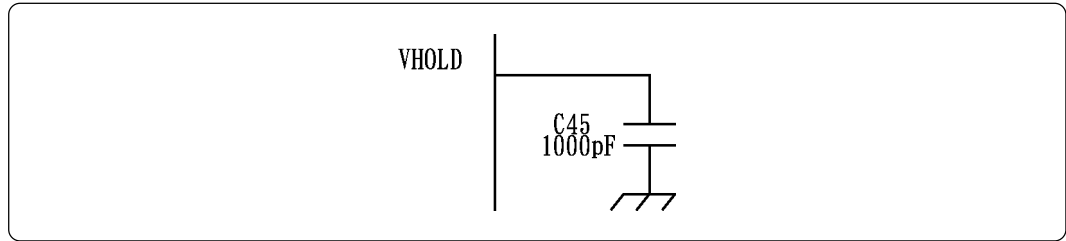

Figure 4.10 VHOLD signal circuit

(4) Figure 4.11 shows the part numbers and the constants of the parts of the signal OSC1, OSC2.

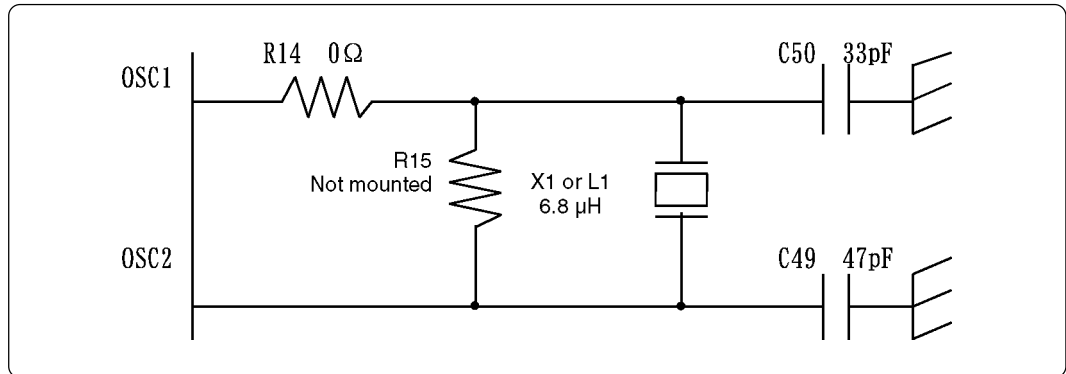

Figure 4.11 OSC1, OSC2 signal circuit

4.5 Procedure for Setting Switches

- (1) You must remove the cover of the M306V0T-RPD-E in order to set the switches. To do so, remove the four screws holding the top cover. There are two screws on each side (see Figure 4.12). Be sure to turn OFF the power before attempting to change the switch settings. If the power is ON, you may damage the circuits.

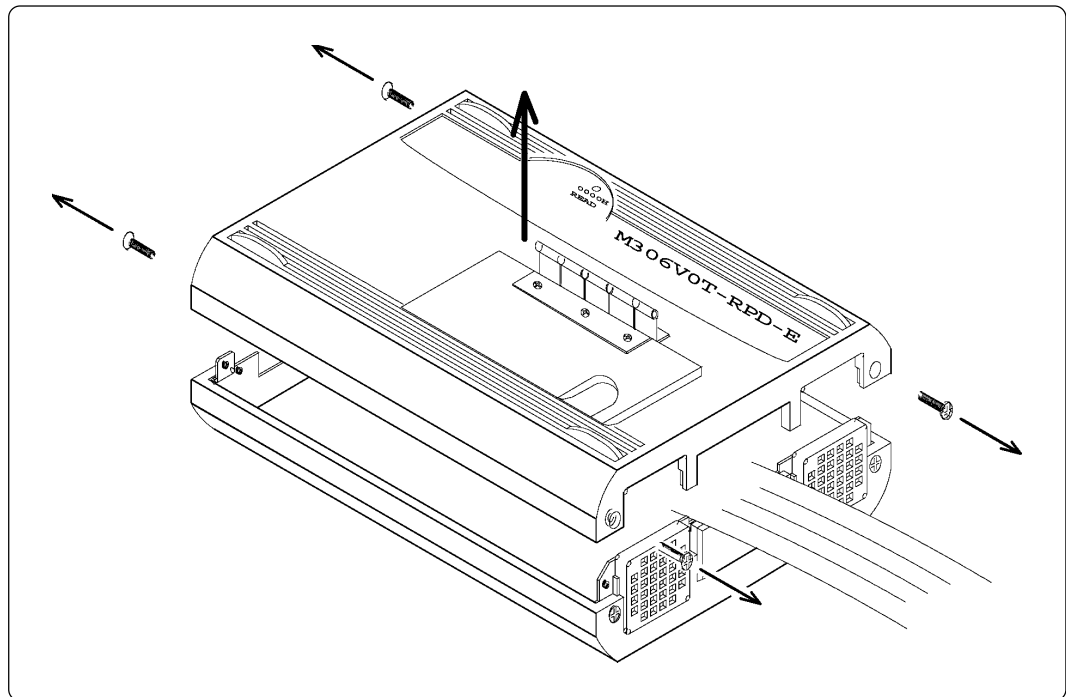

Figure 4.12 Removing M306V0T-RPD-E cover

- (2) After removing the cover, set the switches referring to Table 4.1 (page 19).
- (3) After setting the switches, replace the cover by reversing the procedure for its removal.
 1. Replace the M306V0T-RPD-E cover.
 2. Replace the screws (two on each side) holding the M306V0T-RPD-E cover in place.

4.6 Procedure for Writing MCU File

You may need to change the contents of the MCU file, depending on the MCU being developed. The MCU file is in the same directory as the emulator debugger. The file name is M30620.MCU for the M16C/6V group MCUs.

The MCU file contains the following information: SFR area, internal RAM area, internal ROM area, and firmware filename. Set these according to the MCU being developed. Use your editor to edit the MCU file.

0	SFR area starting address
3FF	SFR area ending address
2C00	Internal RAM starting address
3FFF	Internal RAM ending address
F0000	Internal ROM starting address
FFFFFF	Internal ROM ending address
M30620B	Firmware filename (Do not edit.)

Chapter 5. Method of Connection

5.1 Connecting Emulator Main Unit

Use the FLX120-RPD 120-pin flexible cable to connect the emulator main unit and M306V0T-RPD-E. Figure 5.1 shows how to connect the emulator main unit and FLX120-RPD.

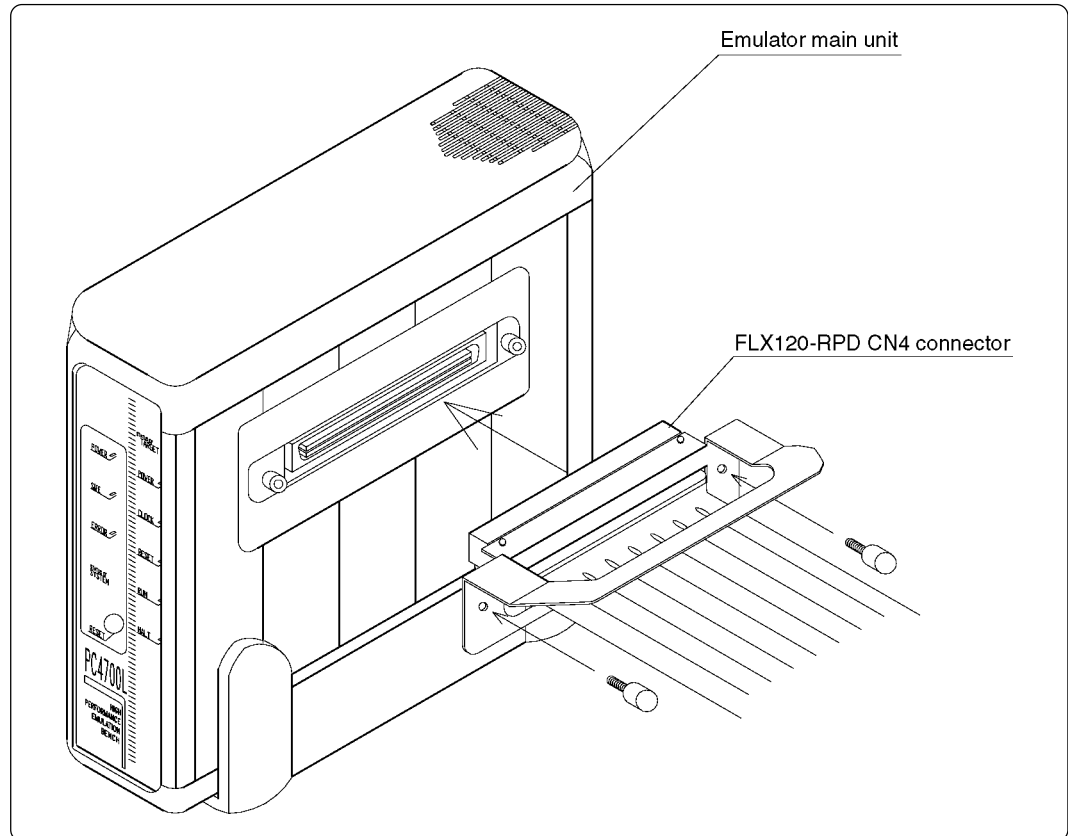

Figure 5.1 Connecting emulator main unit and FLX120-RPD

Connect FLX120-RPD with M306V0T-RPD-E. Figure 5.2 shows how to connect M306V0T-RPD-E and FLX120-RPD.

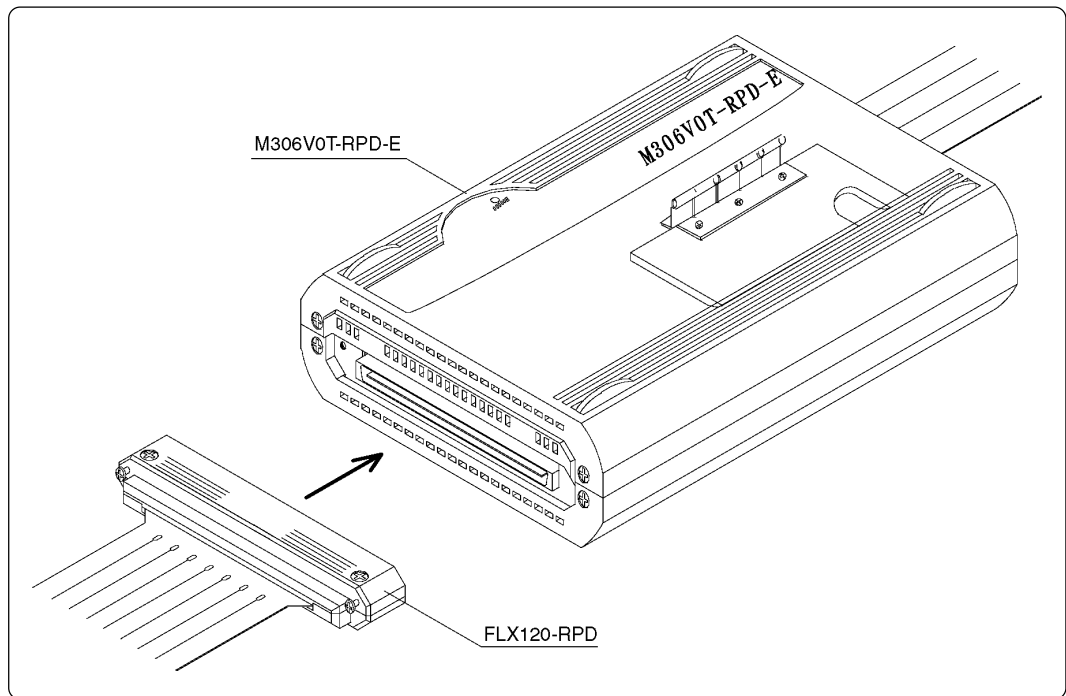

Figure 5.2 Connecting M306V0T-RPD-E and FLX120-RPD

CAUTION

Note on Connecting the Cable:

- Always shut OFF power before connecting the cable. The power ON state could destroy internal circuits.

5.2 Connecting Target System

Figure 5.3 shows connections between emulator probes and target systems. For more details, refer to "Renesas Tools - Accessory Guide".

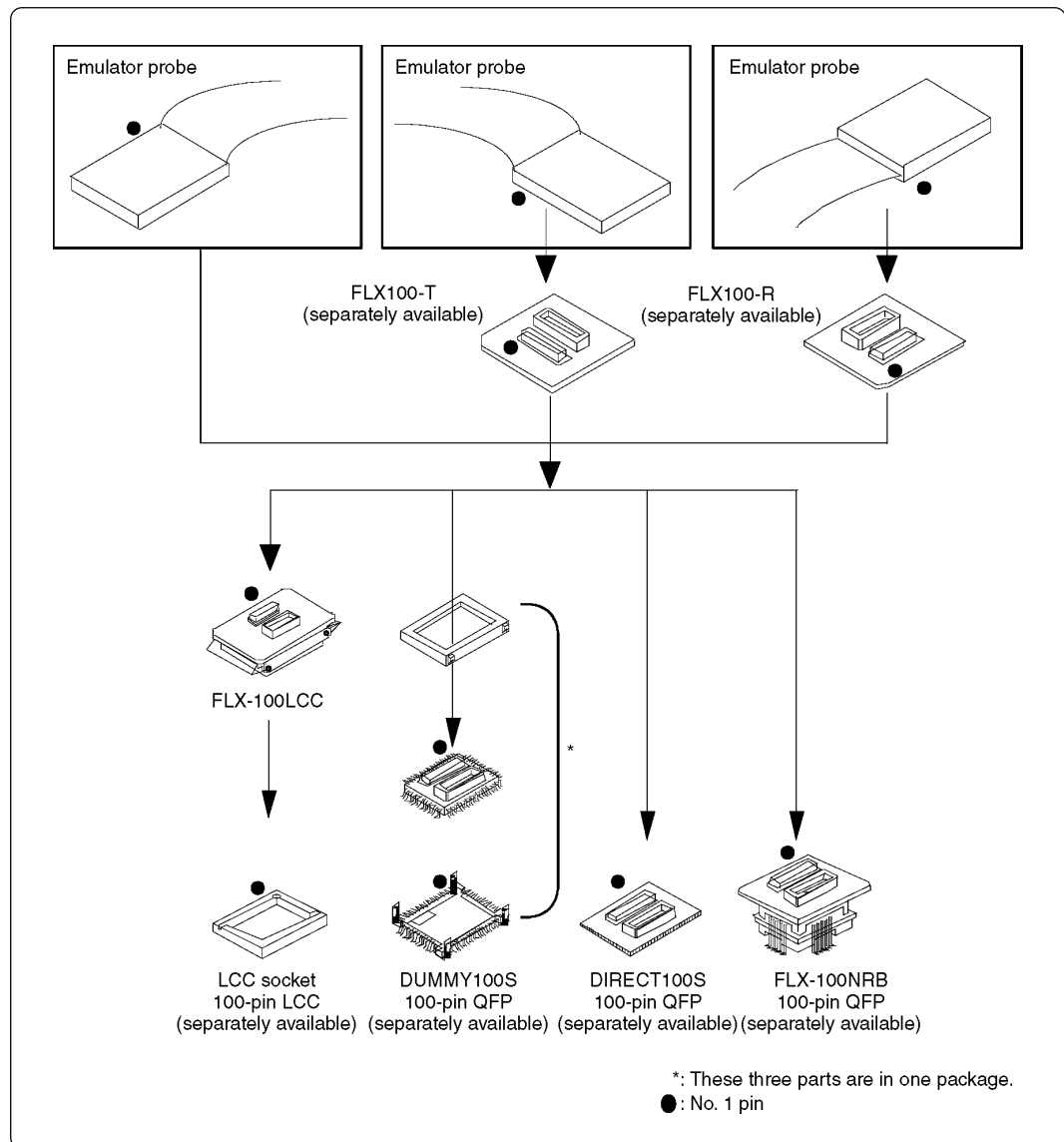

Figure 5.3 Connection to target systems

CAUTION

Notes on Connecting the Target Systems:

- Be sure to turn off the power before making connections. Otherwise, the internal circuits may be damaged.
- The small connectors of the FLX100 and FLX-100LCC are guaranteed for only 20 insertion/removal iterations.

Chapter 6. Constraints

(1) BRK instruction

The BRK instruction cannot be used.

(2) Software and hardware breaks

- a. Do not set simultaneous software and hardware breaks.
- b. Do not use software breaks for areas for which the MAP setting is EXTERNAL.

(3) Using multiplex bus with the PC4701L emulator

You can only use Fetch as a hardware break condition for the multiplex bus area.

(4) Using address match interrupts

- a. Do not set a software break at the same address as you have set an address match interrupt.
- b. Do not set a hardware break within the 4 bytes leading up to the address at which an address match interrupt is invoked.
- c. When the address at which an address match interrupt occurs is achieved by one-step execution, the address match interrupt processing and the first command on return from the interrupt are executed simultaneously.

(5) Software resets

Do not use software resets.

(6) Watchdog function

If using the watchdog function, you can only use program execution. If you want to use debugger functions other than program execution, disable the watchdog function.

Chapter 7. Operation Timing (Memory Expansion and Microprocessor Modes)

7.1 Separate Bus (no wait)

Table 7.1 and Figure 7.1 show bus timing when using the memory expansion mode and microprocessor mode (separate bus, no wait).

Table 7.1 Memory expansion mode and microprocessor mode (separate bus, no wait)

Symbol	Parameter	M306V0EEFP [ns]		M306V0T-RPD-E [ns]	
		Min.	Max.	Min.	Max.
td(BCLK-AD)	Address output delay time	-	25	-	47
th(BCLK-AD)	Address output hold time (BCLK)	4	-	4	-
th(RD-AD)	Address output hold time (\overline{RD})	0	-	-5	-
th(WR-AD)	Address output hold time (\overline{WR})	0	-	-3	-
td(BCLK-CS)	Chip-select output delay time	-	25	-	36
th(BCLK-CS)	Chip-select output hold time (BCLK)	4	-	4	-
td(BCLK-ALE)	ALE signal output delay time	-	25	-	14
th(BCLK-ALE)	ALE signal output hold time	-4	-	-4	-
td(BCLK-RD)	\overline{RD} signal output delay time	-	25	-	40
th(BCLK-RD)	\overline{RD} signal output hold time	0	-	0	-
td(BCLK-WR)	\overline{WR} signal output delay time	-	25	-	40
th(BCLK-WR)	\overline{WR} signal output hold time	0	-	0	-
td(BCLK-DB)	Data output delay time (BCLK)	-	40	-	70
th(BCLK-DB)	Data output hold time (BCLK)	4	-	2	-
td(DB-WR)	Data output delay time (\overline{WR})	(Note 1)	-	(Note 2)	-
th(WR-DB)	Data output hold time (\overline{WR})	0	-	0	-

Note 1. Compute bus timing according to BCLK frequency. Use the below formula.

$$td(DB-WR) = \frac{10^9}{f(BCLK) \times 2} - 40 \text{ [ns]}$$

Note 2. Compute bus timing according to BCLK frequency. Use the below formula.

$$td(DB-WR) = \frac{10^9}{f(BCLK) \times 2} - 55 \text{ [ns]}$$

V_{CC} = 5 V

Memory expansion mode or microprocessor mode (no wait)

Read timing

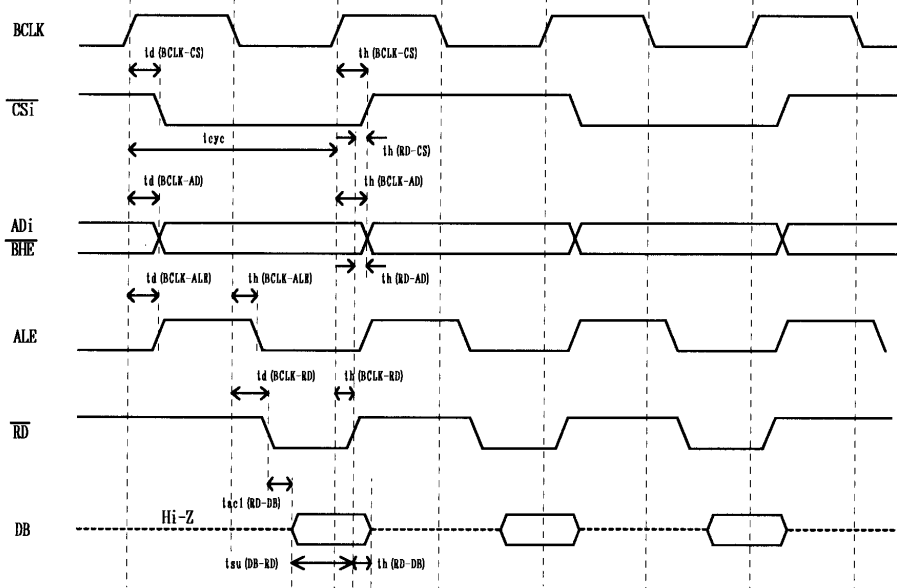

Write timing

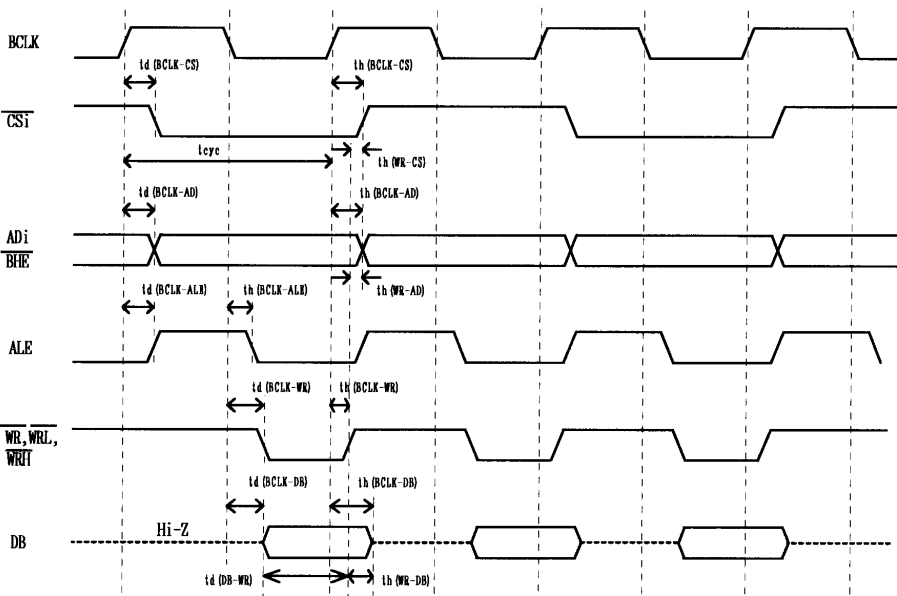

Measurement Condition

- V_{CC} = 5 V
- Input timing voltage: V_{IL} = 0.8 V, V_{IH} = 2.5 V
- Output timing voltage: V_{OL} = 0.8 V, V_{OH} = 2.0 V

Figure 7.1 Memory expansion mode and microprocessor mode (separate bus, no wait)

7.2 Separate Bus (with wait), When Accessing to External Memory Area

Table 7.2 and Figure 7.2 show bus timing when using the memory expansion mode and microprocessor mode (with wait, when accessing to the external memory area).

Table 7.2 Memory expansion mode and microprocessor mode (separate bus, with wait)

Symbol	Parameter	M306V0EEFP [ns]		M306V0T-RPD-E [ns]	
		Min.	Max.	Min.	Max.
td(BCLK-AD)	Address output delay time	-	25	-	47
th(BCLK-AD)	Address output hold time (BCLK)	4	-	4	-
th(RD-AD)	Address output hold time (\overline{RD})	0	-	-5	-
th(WR-AD)	Address output hold time (\overline{WR})	0	-	-3	-
td(BCLK-CS)	Chip-select output delay time	-	25	-	36
th(BCLK-CS)	Chip-select output hold time (BCLK)	4	-	4	-
td(BCLK-ALE)	ALE signal output delay time	-	25	-	14
th(BCLK-ALE)	ALE signal output hold time	-4	-	-4	-
td(BCLK-RD)	\overline{RD} signal output delay time	-	25	-	40
th(BCLK-RD)	\overline{RD} signal output hold time	0	-	0	-
td(BCLK-WR)	\overline{WR} signal output delay time	-	25	-	40
th(BCLK-WR)	\overline{WR} signal output hold time	0	-	0	-
td(BCLK-DB)	Data output delay time (BCLK)	-	40	-	70
th(BCLK-DB)	Data output hold time (BCLK)	4	-	2	-
td(DB-WR)	Data output delay time (\overline{WR})	(Note 1)	-	(Note 2)	-
th(WR-DB)	Data output hold time (\overline{WR})	0	-	0	-

Note 1. Compute bus timing according to BCLK frequency. Use the below formula.

$$td(DB-WR) = \frac{10^9}{f(BCLK) \times 2} - 40 \text{ [ns]}$$

Note 2. Compute bus timing according to BCLK frequency. Use the below formula.

$$td(DB-WR) = \frac{10^9}{f(BCLK) \times 2} - 55 \text{ [ns]}$$

V_{CC} = 5 V

Memory expansion mode or microprocessor mode
(with wait, when accessing to the external memory area)

Read timing

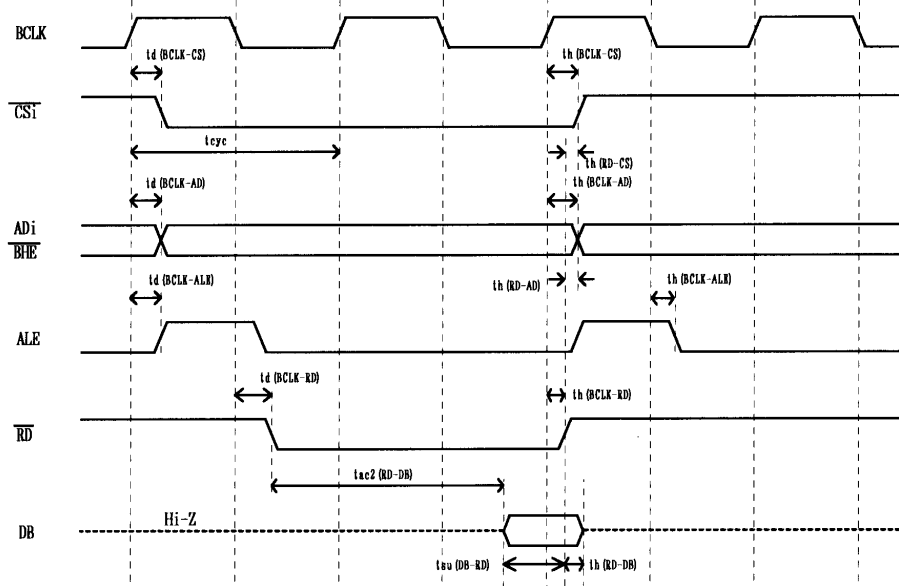

Write timing

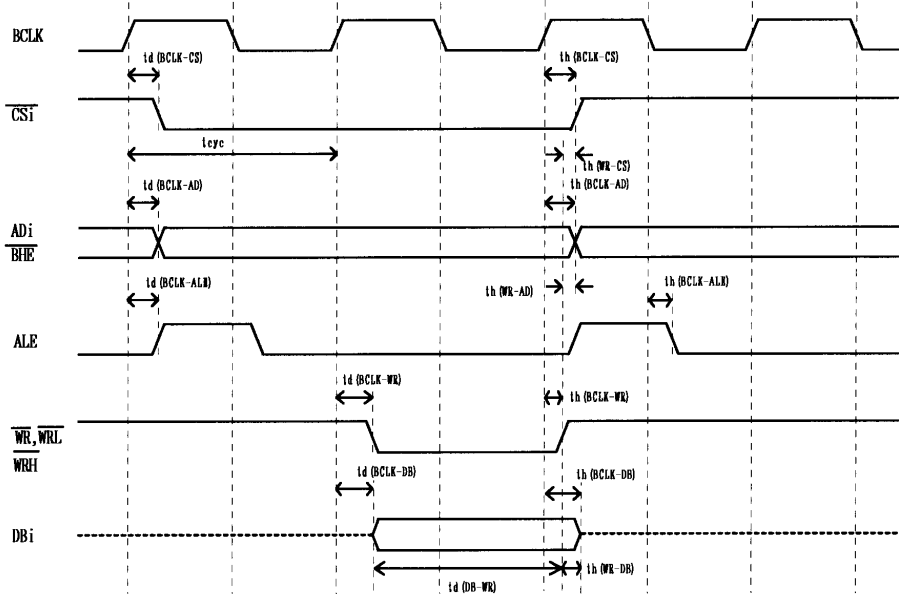

Measurement Condition

- V_{CC} = 5 V
- Input timing voltage: V_{IL} = 0.8 V, V_{IH} = 2.5 V
- Output timing voltage: V_{OL} = 0.8 V, V_{OH} = 2.0 V

Figure 7.2 Memory expansion mode and microprocessor mode (separate bus, with wait)

7.3 Multiplex Bus (with wait), When Accessing to External Memory Area

Table 7.3 and Figure 7.3 show bus timing when using the memory expansion mode and microprocessor mode (with wait, when accessing to the external memory area).

Table 7.3 Memory expansion mode and microprocessor mode (multiplex bus, with wait)

Symbol	Parameter	M306V0EEFP [ns]		M306V0T-RPD-E [ns]	
		Min.	Max.	Min.	Max.
td(BCLK-AD)	Address output delay time	-	25	-	47
th(BCLK-AD)	Address output hold time (BCLK)	4	-	4	-
th(RD-AD)	Address output hold time (\overline{RD})	(Note 1)	-	(Note 2)	-
th(WR-AD)	Address output hold time (\overline{WR})	(Note 1)	-	(Note 2)	-
td(BCLK-CS)	Chip-select output delay time	-	25	-	36
th(BCLK-CS)	Chip-select output hold time (BCLK)	4	-	4	-
th(RD-CS)	Chip-select output hold time (\overline{RD})	(Note 1)	-	(Note 2)	-
th(WR-CS)	Chip-select output hold time (\overline{WR})	(Note 1)	-	(Note 2)	-
td(BCLK- \overline{RD})	RD signal output delay time	-	25	-	38
th(BCLK- \overline{RD})	RD signal output hold time	0	-	0	-
td(BCLK- \overline{WR})	WR signal output delay time	-	25	-	40
th(BCLK- \overline{WR})	WR signal output hold time	0	-	0	-
td(BCLK-DB)	Data output delay time (BCLK)	-	40	-	40
th(BCLK-DB)	Data output hold time (BCLK)	4	-	4	-
td(DB-WR)	Data output delay time (\overline{WR})	(Note 1)	-	(Note 2)	-
th(WR-DB)	Data output hold time (\overline{WR})	(Note 1)	-	(Note 2)	-
td(BCLK-ALE)	ALE signal output delay time (BCLK)	-	25	-	14
th(BCLK-ALE)	ALE signal output hold time (BCLK)	-4	-	-4	-
td(AD-ALE)	ALE signal output delay time (ADDRESS)	(Note 1)	-	(Note 2)	-
th(ALE-AD)	ALE signal output hold time (ADDRESS)	50	-	50	-
td(AD-RD)	ALE signal output hold time (ADDRESS)	0	-	0	-
td(AD-WR)	ALE signal output hold time (ADDRESS)	0	-	0	-
tdz(RD-AD)	ALE signal output hold time (ADDRESS)	-	8	-	13

Note 1. Compute bus timing according to BCLK frequency. Use the below formula.

$$\begin{aligned} \text{th(RD-AD)} &= \frac{10^9}{f(\text{BCLK}) \times 2} \quad [\text{ns}] & \text{td(DB-WR)} &= \frac{10^9 \times 3}{f(\text{BCLK}) \times 2} - 40 \quad [\text{ns}] \\ \text{th(RW-AD)} &= \frac{10^9}{f(\text{BCLK}) \times 2} \quad [\text{ns}] & \text{th(WR-DB)} &= \frac{10^9}{f(\text{BCLK}) \times 2} \quad [\text{ns}] \\ \text{th(RD-CS)} &= \frac{10^9}{f(\text{BCLK}) \times 2} \quad [\text{ns}] & \text{td(DB-WR)} &= \frac{10^9}{f(\text{BCLK}) \times 2} - 25 \quad [\text{ns}] \\ \text{th(WR-CS)} &= \frac{10^9}{f(\text{BCLK}) \times 2} \quad [\text{ns}] \end{aligned}$$

Note 2. Compute bus timing according to BCLK frequency. Use the below formula.

$$\begin{aligned} \text{th(RD-AD)} &= \frac{10^9}{f(\text{BCLK}) \times 2} - 10 \quad [\text{ns}] & \text{td(DB-WR)} &= \frac{10^9 \times 3}{f(\text{BCLK}) \times 2} - 24 \quad [\text{ns}] \\ \text{th(RW-AD)} &= \frac{10^9}{f(\text{BCLK}) \times 2} - 10 \quad [\text{ns}] & \text{th(WR-DB)} &= \frac{10^9}{f(\text{BCLK}) \times 2} - 35 \quad [\text{ns}] \\ \text{th(RD-CS)} &= \frac{10^9}{f(\text{BCLK}) \times 2} - 12 \quad [\text{ns}] & \text{td(DB-WR)} &= \frac{10^9}{f(\text{BCLK}) \times 2} - 35 \quad [\text{ns}] \\ \text{th(WR-CS)} &= \frac{10^9}{f(\text{BCLK}) \times 2} - 12 \quad [\text{ns}] \end{aligned}$$

Memory expansion mode or microprocessor mode
(with wait, when accessing to the external memory area)

Read timing

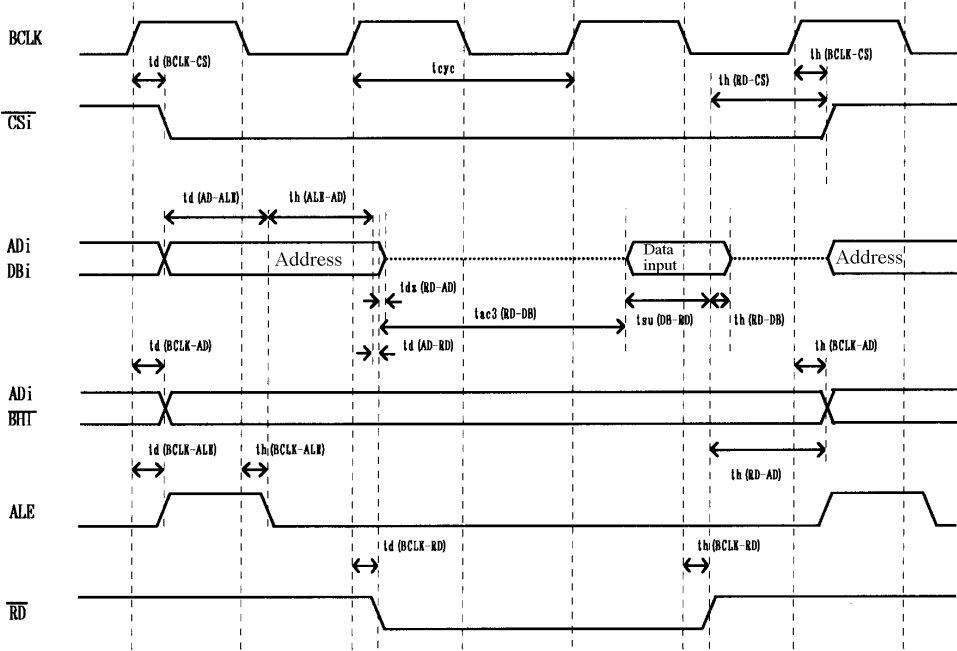

Write timing

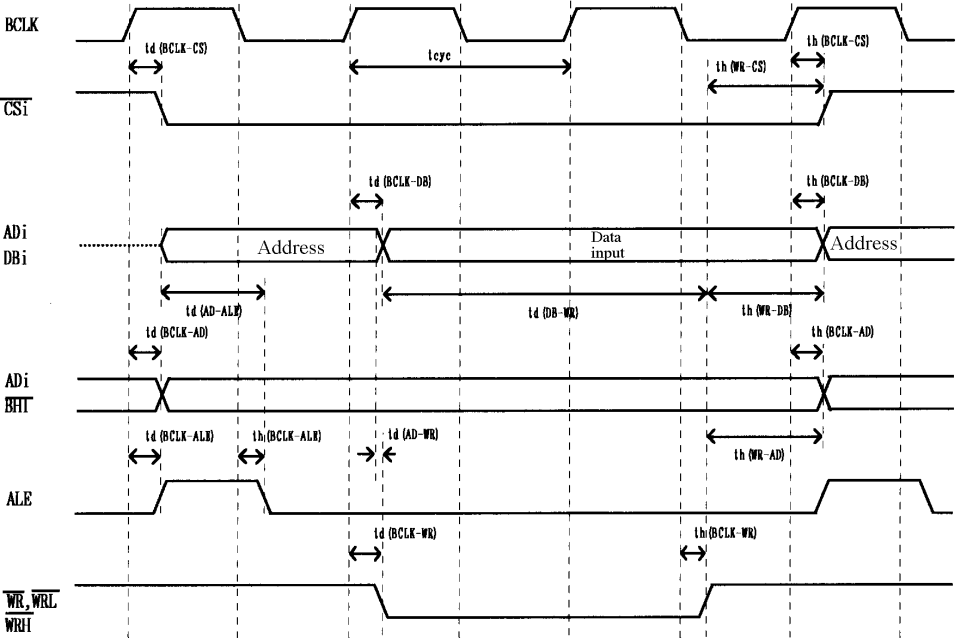

- Measurement Condition
- V_{CC} = 5 V
 - Input timing voltage: V_{IL} = 0.8 V, V_{IH} = 2.5 V
 - Output timing voltage: V_{OL} = 0.8 V, V_{OH} = 2.0 V

Figure 7.3 Memory expansion mode and microprocessor mode (multiplex bus, with wait)

7.4 Timing Requirements

Table 7.4 and Figure 7.4 show timing requirements when using the memory expansion mode and microprocessor mode.

Table 7.4 Timing requirements ($V_{cc} = 5 V$)

Symbol	Parameter	M306V0EEFP [ns]		M306V0T-RPD-E [ns]	
		Min.	Max.	Min.	Max.
tsu(DB-RD)	Data input setup time	40	-	80	-
tsu(RDY-BCLK)	$\overline{\text{RDY}}$ input setup time	30	-	50	-
tsu(HOLD-BCLK)	$\overline{\text{HOLD}}$ input setup time	40	-	(Note 1)	-
th(RD-DB)	Data input hold time	0	-	0	-
th(BCLK-RDY)	$\overline{\text{RDY}}$ input hold time	0	-	0	-
th(BCLK-HOLD)	$\overline{\text{HOLD}}$ input hold time	0	-	0	-
th(BCLK-HLDA)	$\overline{\text{HLDA}}$ output delay time	-	40	-	40

Note 1. $\text{tsu}(\text{HOLD-BCLK}) = \frac{10^9 \times 3}{f(\text{BCLK}) \times 2} + 20$

Memory expansion mode or microprocessor mode

V_{CC} = 5 V

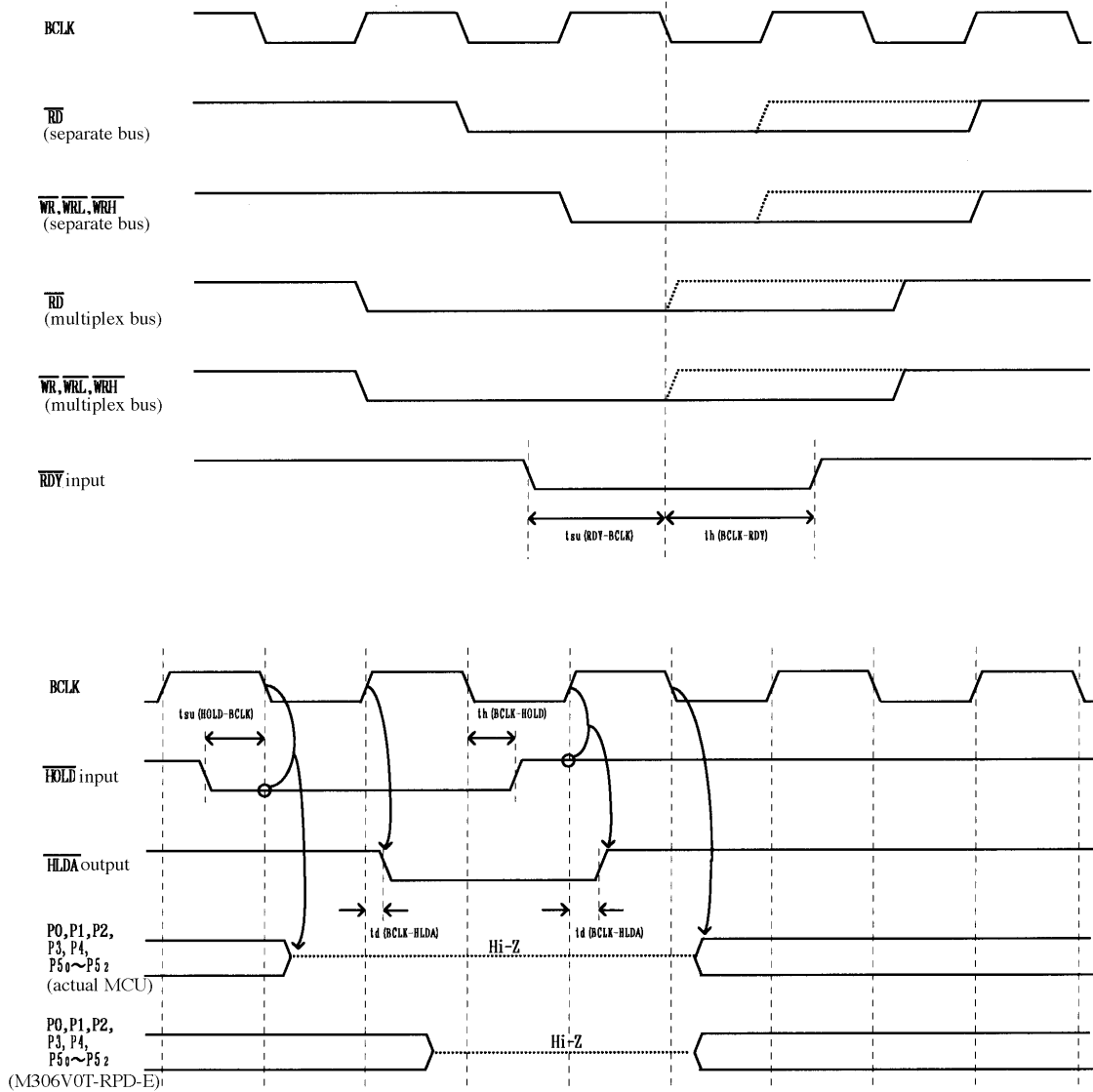

Note 1. P0₀ to P5₂ will be high-impedance status regardless of the input level of BYTE pin and ports P4₀ to P4₃ function selection bit (PM06) of the processor mode register 0.

Note 2. This product will be high-impedance delaying by 0.5 cycles than an actual MCU.

Measurement Condition

- V_{CC} = 5 V
- Input timing voltage: V_{IL} = 1.0 V, V_{IH} = 4.0 V
- Output timing voltage: V_{OL} = 2.5 V, V_{OH} = 2.5 V

Figure 7.4 Timing requirements (V_{CC} = 5 V)

Chapter 8. Electrical Characteristics

Tables 8.1 and 8.2 show IC electrical characteristics of user's interface.

Table 8.1 Electrical characteristics of 74HC4066FS (P0₀ - P5₂)

Symbol	Parameter	Standard value			Unit	
		Vcc	Min.	Typ.		Max.
V _{IHC}	'H' level control input voltage	2.0 4.5	1.5 3.15	- -	- -	V
V _{ILC}	'L' level control input voltage	2.0 4.5	- -	- -	0.5 1.35	V
R _{ON}	On resistance	2.0 4.5	- -	2000 100	- 200	Ω
ΔR _{ON}	On resistance difference between arbitrary 2 switches in a package	2.0 4.5	- -	50 3	- -	Ω
I _{OFF}	Switch input/output off leakage current	- 6.0	- -	- -	- ±	μA

Table 8.2 Electrical characteristics of M60074-0111FP (P5₃ - P5₇, 5 V)

Symbol	Parameter	Standard value			Unit
		Min.	Typ.	Max.	
V _{T-} V _{T+} V _{TH}	Input voltage	1.25 2.3 0.3	- - -	2.3 3.7 1.2	V
V _{OH}	'H' level output voltage	4.95	-	-	V
V _{OL}	'L' level output voltage	-	-	0.05	V
I _{OH}	'H' level output current	-	-	-8	mA
I _{OL}	'L' level output current	8	-	-	mA
I _{IH}	'H' level input current	-1	-	+1	μA
I _{IL}	'L' level input current	-1	-	+1	μA
I _{OZH}	Off state 'H' level output current	-1	-	+1	μA
I _{OZL}	Off state 'L' level output current	-1	-	+1	μA
C _{IO}	Input/output terminal capacity	-	7	15	pF

Chapter 9. Maintenance and Guarantee

9.1 Maintenance

If dust or dirt collects on any equipment of your emulation system, wipe it off with a dry soft cloth. Do not use thinner or other solvents because these chemicals can cause the equipment's surface coating to separate.

9.2 Guarantee

If your product becomes faulty within one year after its purchase while being used under good conditions by observing "Precautions for Safety" described in Chapter 1 of this user's manual, we will repair or replace your faulty product free of charge. Note, however, that if your product's fault is raised by any one of the following causes, we will repair it or replace it with new one with extra-charge:

- Misuse, abuse, or use under extraordinary conditions
- Unauthorized repair, remodeling, maintenance, and so on
- Inadequate user's system or misuse of it
- Fires, earthquakes, and other unexpected disasters

In the above cases, contact your local distributor. If your product is being leased, consult the leasing company or the owner.

9.3 Repair Provisions

(1) Repair with extra-charge

The products elapsed more than one year after purchase can be repaired with extra-charge.

(2) Replacement with extra-charge

If your product's fault falls in any of the following categories, the fault will be corrected by replacing the entire product instead of repair, or you will be advised to purchase new one, depending on the severity of the fault.

- Faulty or broken mechanical portions
- Flaw, separation, or rust in coated or plated portions
- Flaw or cracks in plastic portions
- Faults or breakage caused by improper use or unauthorized repair or modification
- Heavily damaged electric circuits due to overvoltage, overcurrent or shorting of power supply
- Cracks in the printed circuit board or burnt-down patterns
- Wide range of faults that makes replacement less expensive than repair
- Unlocatable or unidentified faults

(3) Expiration of the repair period

When a period of one year elapses after the model was dropped from production, repairing products of the model may become impossible.

(4) Transportation fees at sending your product for repair

Please send your product to us for repair at your expense.

9.4 How to Request for Repair

If your product is found faulty, follow the procedure below to send your product for repair.

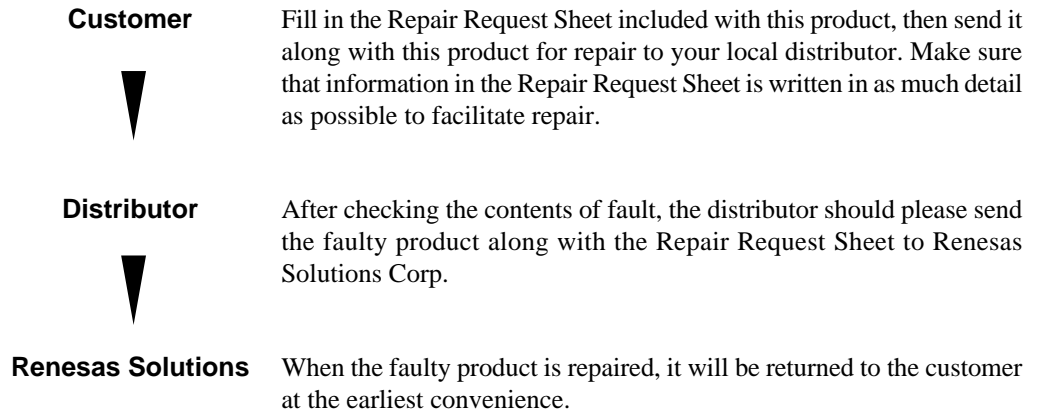

CAUTION

Note on Transporting the Product:



- When sending your product for repair, use the packing box and cushion material supplied with this product when delivered to you and specify handling caution for it to be handled as precision equipment. If packing of your product is not complete, it may be damaged during transportation. When you pack your product in a bag, make sure to use conductive polyvinyl supplied with this product (usually a blue bag). When you use other bags, they may cause a trouble on your product because of static electricity.

Chapter 10. Troubleshooting

10.1 When M306V0T-RPD-E Does Not Work Properly

- (1) Emulator main unit cannot be powered up.
 - Check to see if the AC power cord is firmly plugged into the receptacle.
 - Check to see if the AC power 3P-2P converting connector is firmly connected.

- (2) The M306V0T-RPD-E does not start up when the target system is connected with the PC4701 system. (The Error LED of the emulator main unit lights up.)
 - Check (1) described above.
 - Check whether the emulator main unit and the FLX120-RPD are firmly connected.
 - Check whether the FLX120-RPD and the M306V0T-RPD-E are firmly connected.
 - Check whether the M306V0T-RPD-E and the target system are firmly connected.
 - Check whether the power and GND are supplied to the target system.
 - Check whether switches of the M306V0T-RPD-E are firmly set. (Refer to Chapter 4. for setting switches.)
 - Check whether the $\overline{\text{RESET}}$ pin and $\overline{\text{NMI}}$ pin are held 'HIGH' when the target system is connected.
 - Check whether the $\overline{\text{HOLD}}$ pin and $\overline{\text{RDY}}$ pin are held 'HIGH' when in the microprocessor or memory expansion mode.
 - Check whether the oscillator circuit of the target system is oscillating correctly when using a target's oscillator.
 - Check whether correct firmware is downloaded in the emulator main unit. (Refer to the user's manual of the emulator debugger about how to download firmware.)

- (3) If the PC4701 system does not pass all self-checks (excluding when an target system error occurs), there is the possibility of trouble in the system. In such case, contact the place of purchase.

Please take note that self-check should be executed under the following conditions.

 - The target system is not connected.
 - The Switch SW6 is set to 'L' position, SW7 to '16' (See Chapter 4).

When the condition does not improve even if you check the items above, troubles described below are considered.

 - Trouble of the evaluation MCU
 - Trouble of the M306V0T-RPD-E
 - Trouble of the PC4701 emulator main unit

Appendix A. External Dimensions

A.1 External Dimensions of the M306V0T-RPD-E

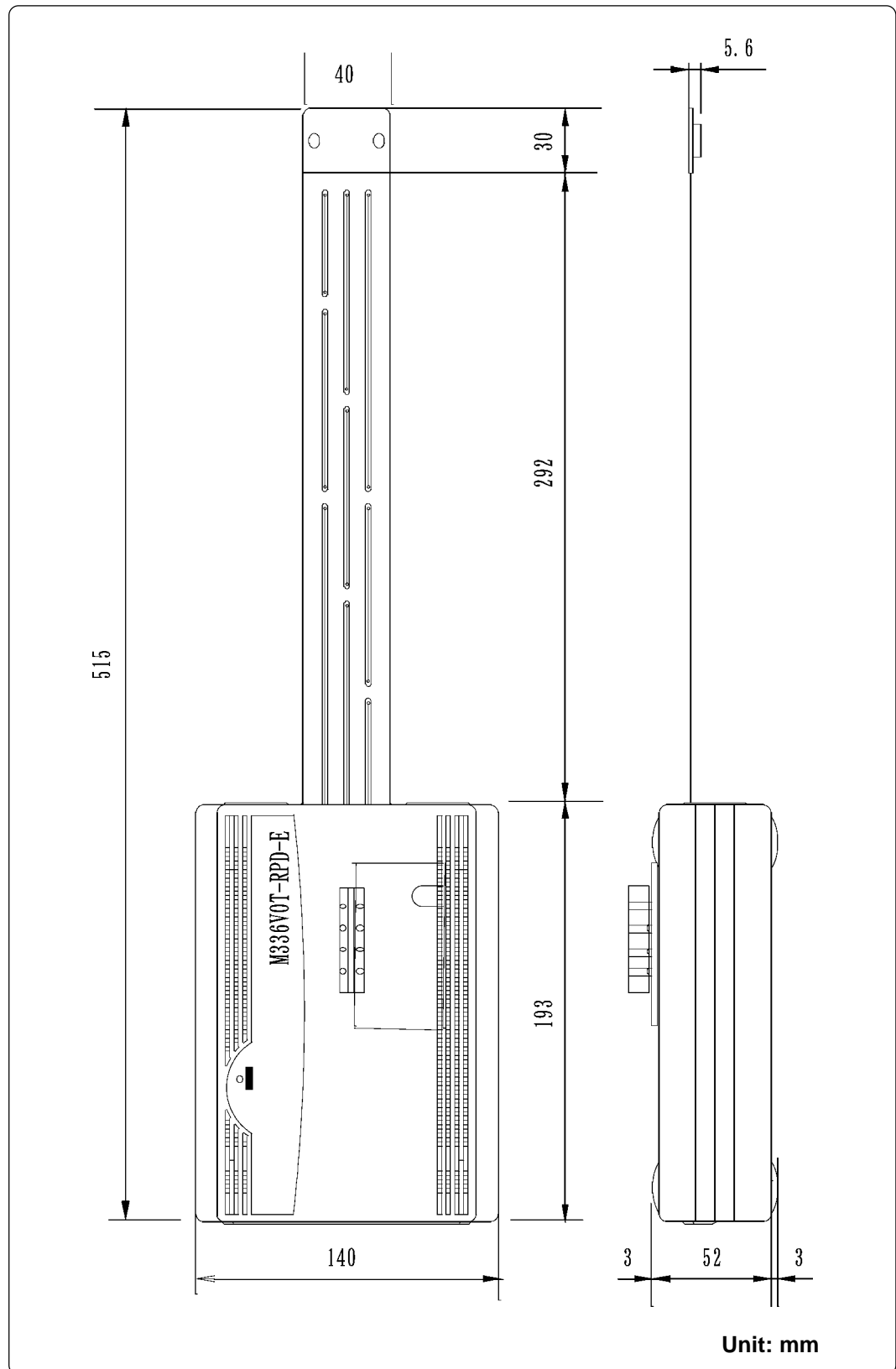

Figure A.1 External dimensions of the M306V0T-RPD-E

A.2 External Dimensions of the FLX-100LCC

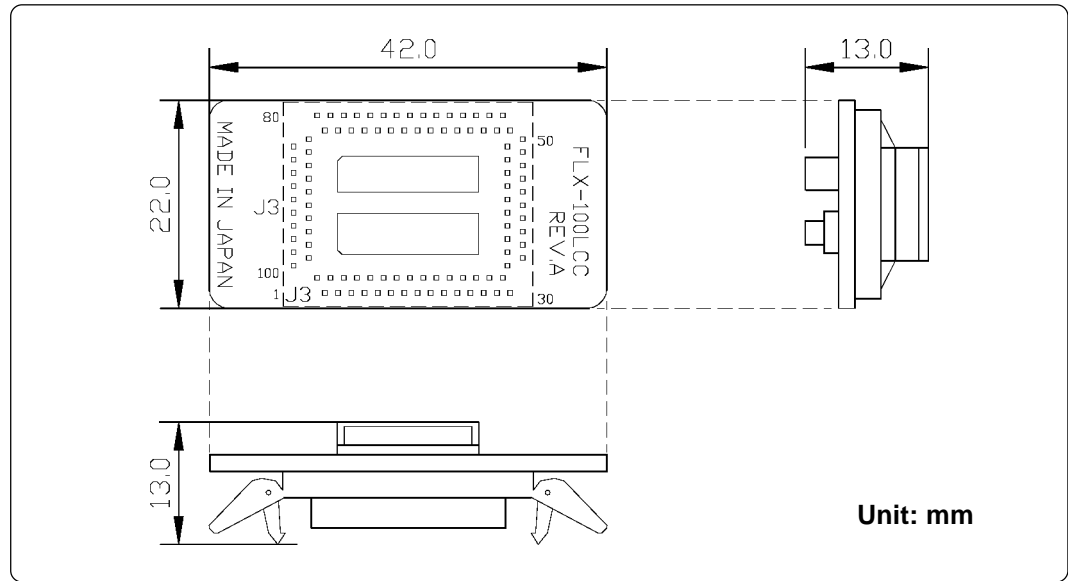

Figure A.2 External dimensions of the FLX-100LCC

Appendix B. Connection Diagrams

Figures B.1 and B.2 show the connection diagrams of the M306V0T-RPD-E. These connection diagrams mainly show the interface section with a target system, and the circuits which are not connected to the target system such as the emulator's control system are omitted.

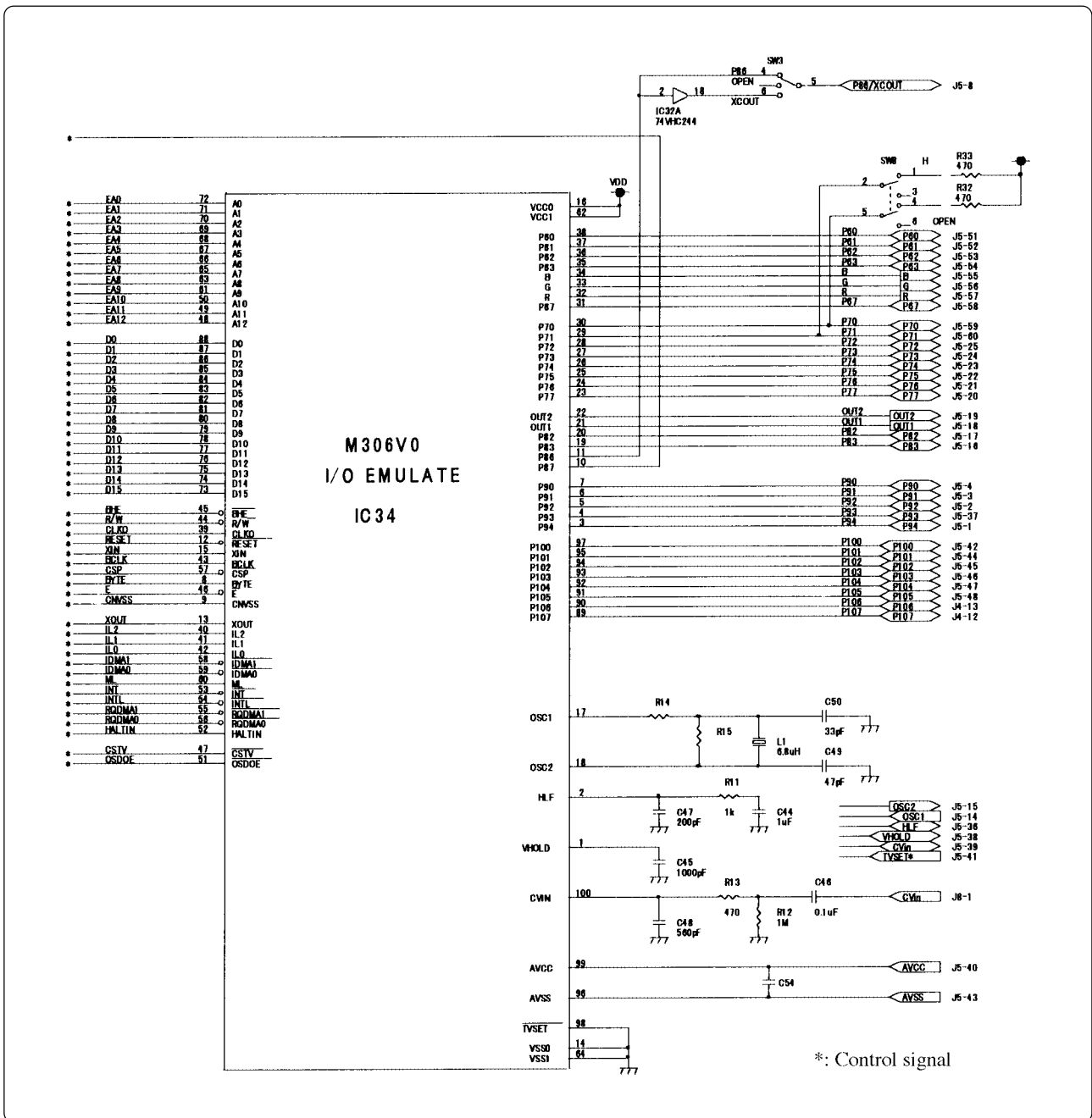

Figure B.1 Connection diagram of the M306V0T-RPD-E (1/2)

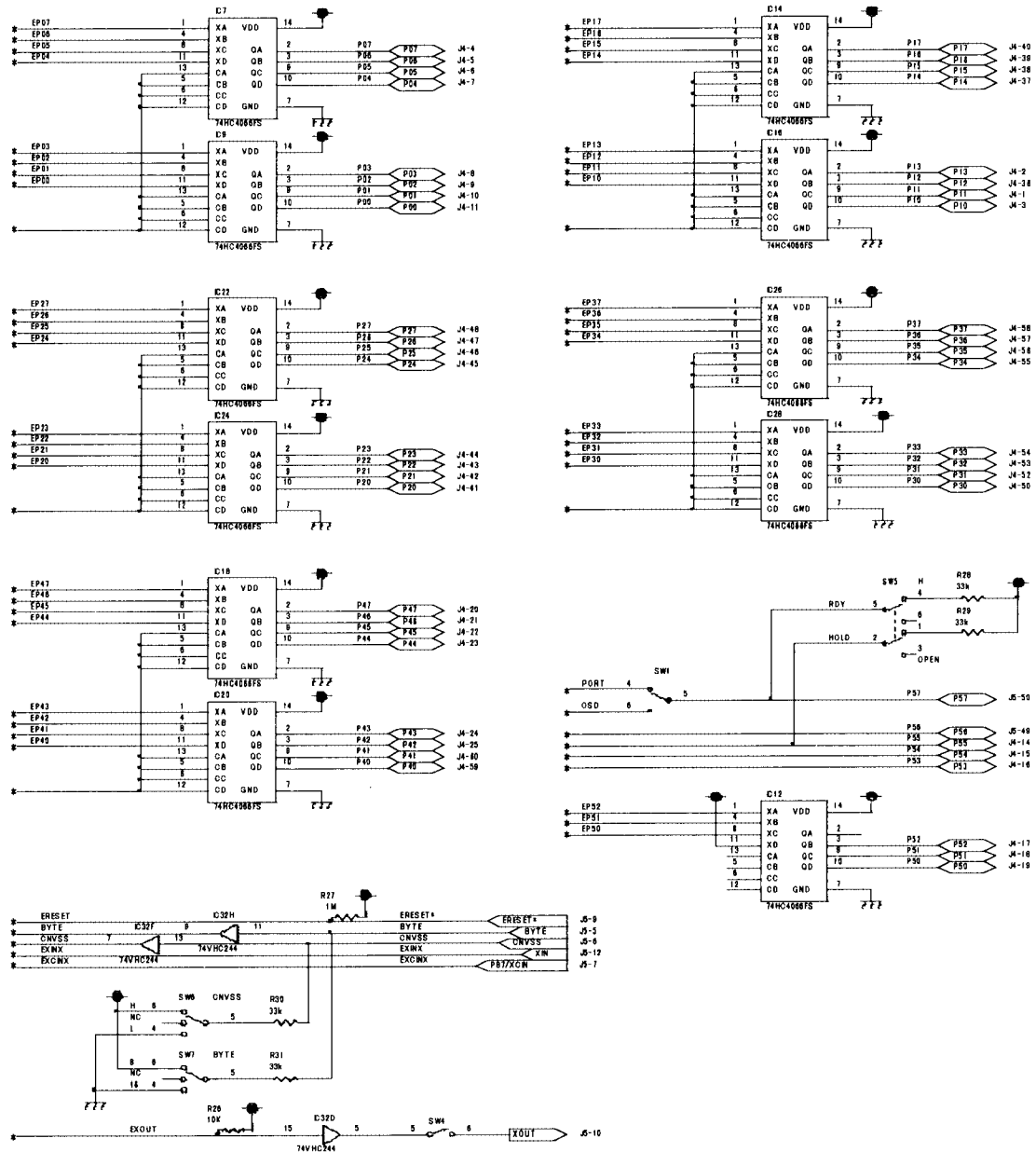

Figure B.2 Connection diagram of the M306V0T-RPD-E (2/2)

M306V0T-RPD-E User's Manual

Rev.1.00
October 16, 2003
REJ10J0380-0100Z

COPYRIGHT ©2003 RENESAS TECHNOLOGY CORPORATION
AND RENESAS SOLUTIONS CORPORATION ALL RIGHTS RESERVED

M306V0T-RPD-E User's Manual



Renesas Electronics Corporation

1753, Shimonumabe, Nakahara-ku, Kawasaki-shi, Kanagawa 211-8668 Japan

REJ10J0380-0100Z