

To our customers,

---

## Old Company Name in Catalogs and Other Documents

---

On April 1<sup>st</sup>, 2010, NEC Electronics Corporation merged with Renesas Technology Corporation, and Renesas Electronics Corporation took over all the business of both companies. Therefore, although the old company name remains in this document, it is a valid Renesas Electronics document. We appreciate your understanding.

Renesas Electronics website: <http://www.renesas.com>

April 1<sup>st</sup>, 2010  
Renesas Electronics Corporation

Issued by: Renesas Electronics Corporation (<http://www.renesas.com>)

Send any inquiries to <http://www.renesas.com/inquiry>.

## Notice

1. All information included in this document is current as of the date this document is issued. Such information, however, is subject to change without any prior notice. Before purchasing or using any Renesas Electronics products listed herein, please confirm the latest product information with a Renesas Electronics sales office. Also, please pay regular and careful attention to additional and different information to be disclosed by Renesas Electronics such as that disclosed through our website.
2. Renesas Electronics does not assume any liability for infringement of patents, copyrights, or other intellectual property rights of third parties by or arising from the use of Renesas Electronics products or technical information described in this document. No license, express, implied or otherwise, is granted hereby under any patents, copyrights or other intellectual property rights of Renesas Electronics or others.
3. You should not alter, modify, copy, or otherwise misappropriate any Renesas Electronics product, whether in whole or in part.
4. Descriptions of circuits, software and other related information in this document are provided only to illustrate the operation of semiconductor products and application examples. You are fully responsible for the incorporation of these circuits, software, and information in the design of your equipment. Renesas Electronics assumes no responsibility for any losses incurred by you or third parties arising from the use of these circuits, software, or information.
5. When exporting the products or technology described in this document, you should comply with the applicable export control laws and regulations and follow the procedures required by such laws and regulations. You should not use Renesas Electronics products or the technology described in this document for any purpose relating to military applications or use by the military, including but not limited to the development of weapons of mass destruction. Renesas Electronics products and technology may not be used for or incorporated into any products or systems whose manufacture, use, or sale is prohibited under any applicable domestic or foreign laws or regulations.
6. Renesas Electronics has used reasonable care in preparing the information included in this document, but Renesas Electronics does not warrant that such information is error free. Renesas Electronics assumes no liability whatsoever for any damages incurred by you resulting from errors in or omissions from the information included herein.
7. Renesas Electronics products are classified according to the following three quality grades: "Standard", "High Quality", and "Specific". The recommended applications for each Renesas Electronics product depends on the product's quality grade, as indicated below. You must check the quality grade of each Renesas Electronics product before using it in a particular application. You may not use any Renesas Electronics product for any application categorized as "Specific" without the prior written consent of Renesas Electronics. Further, you may not use any Renesas Electronics product for any application for which it is not intended without the prior written consent of Renesas Electronics. Renesas Electronics shall not be in any way liable for any damages or losses incurred by you or third parties arising from the use of any Renesas Electronics product for an application categorized as "Specific" or for which the product is not intended where you have failed to obtain the prior written consent of Renesas Electronics. The quality grade of each Renesas Electronics product is "Standard" unless otherwise expressly specified in a Renesas Electronics data sheets or data books, etc.

"Standard": Computers; office equipment; communications equipment; test and measurement equipment; audio and visual equipment; home electronic appliances; machine tools; personal electronic equipment; and industrial robots.

"High Quality": Transportation equipment (automobiles, trains, ships, etc.); traffic control systems; anti-disaster systems; anti-crime systems; safety equipment; and medical equipment not specifically designed for life support.

"Specific": Aircraft; aerospace equipment; submersible repeaters; nuclear reactor control systems; medical equipment or systems for life support (e.g. artificial life support devices or systems), surgical implantations, or healthcare intervention (e.g. excision, etc.), and any other applications or purposes that pose a direct threat to human life.

8. You should use the Renesas Electronics products described in this document within the range specified by Renesas Electronics, especially with respect to the maximum rating, operating supply voltage range, movement power voltage range, heat radiation characteristics, installation and other product characteristics. Renesas Electronics shall have no liability for malfunctions or damages arising out of the use of Renesas Electronics products beyond such specified ranges.
9. Although Renesas Electronics endeavors to improve the quality and reliability of its products, semiconductor products have specific characteristics such as the occurrence of failure at a certain rate and malfunctions under certain use conditions. Further, Renesas Electronics products are not subject to radiation resistance design. Please be sure to implement safety measures to guard them against the possibility of physical injury, and injury or damage caused by fire in the event of the failure of a Renesas Electronics product, such as safety design for hardware and software including but not limited to redundancy, fire control and malfunction prevention, appropriate treatment for aging degradation or any other appropriate measures. Because the evaluation of microcomputer software alone is very difficult, please evaluate the safety of the final products or system manufactured by you.
10. Please contact a Renesas Electronics sales office for details as to environmental matters such as the environmental compatibility of each Renesas Electronics product. Please use Renesas Electronics products in compliance with all applicable laws and regulations that regulate the inclusion or use of controlled substances, including without limitation, the EU RoHS Directive. Renesas Electronics assumes no liability for damages or losses occurring as a result of your noncompliance with applicable laws and regulations.
11. This document may not be reproduced or duplicated, in any form, in whole or in part, without prior written consent of Renesas Electronics.
12. Please contact a Renesas Electronics sales office if you have any questions regarding the information contained in this document or Renesas Electronics products, or if you have any other inquiries.

(Note 1) "Renesas Electronics" as used in this document means Renesas Electronics Corporation and also includes its majority-owned subsidiaries.

(Note 2) "Renesas Electronics product(s)" means any product developed or manufactured by or for Renesas Electronics.

# SuperH™ Family E10A Emulator

Additional Document for User's Manual  
Specific Guide for the SH7144F/  
SH7145F E10A Emulator

Renesas Microcomputer Development  
Environment System

SuperH™ Family / SH7144 Series

SH7144F E10A HS7144KCM02HE



### Keep safety first in your circuit designs!

1. Renesas Technology Corp. puts the maximum effort into making semiconductor products better and more reliable, but there is always the possibility that trouble may occur with them. Trouble with semiconductors may lead to personal injury, fire or property damage.  
Remember to give due consideration to safety when making your circuit designs, with appropriate measures such as (i) placement of substitutive, auxiliary circuits, (ii) use of nonflammable material or (iii) prevention against any malfunction or mishap.

### Notes regarding these materials

1. These materials are intended as a reference to assist our customers in the selection of the Renesas Technology Corp. product best suited to the customer's application; they do not convey any license under any intellectual property rights, or any other rights, belonging to Renesas Technology Corp. or a third party.
2. Renesas Technology Corp. assumes no responsibility for any damage, or infringement of any third-party's rights, originating in the use of any product data, diagrams, charts, programs, algorithms, or circuit application examples contained in these materials.
3. All information contained in these materials, including product data, diagrams, charts, programs and algorithms represents information on products at the time of publication of these materials, and are subject to change by Renesas Technology Corp. without notice due to product improvements or other reasons. It is therefore recommended that customers contact Renesas Technology Corp. or an authorized Renesas Technology Corp. product distributor for the latest product information before purchasing a product listed herein.  
The information described here may contain technical inaccuracies or typographical errors.  
Renesas Technology Corp. assumes no responsibility for any damage, liability, or other loss rising from these inaccuracies or errors.  
Please also pay attention to information published by Renesas Technology Corp. by various means, including the Renesas Technology Corp. Semiconductor home page (<http://www.renesas.com>).
4. When using any or all of the information contained in these materials, including product data, diagrams, charts, programs, and algorithms, please be sure to evaluate all information as a total system before making a final decision on the applicability of the information and products. Renesas Technology Corp. assumes no responsibility for any damage, liability or other loss resulting from the information contained herein.
5. Renesas Technology Corp. semiconductors are not designed or manufactured for use in a device or system that is used under circumstances in which human life is potentially at stake. Please contact Renesas Technology Corp. or an authorized Renesas Technology Corp. product distributor when considering the use of a product contained herein for any specific purposes, such as apparatus or systems for transportation, vehicular, medical, aerospace, nuclear, or undersea repeater use.
6. The prior written approval of Renesas Technology Corp. is necessary to reprint or reproduce in whole or in part these materials.
7. If these products or technologies are subject to the Japanese export control restrictions, they must be exported under a license from the Japanese government and cannot be imported into a country other than the approved destination.  
Any diversion or reexport contrary to the export control laws and regulations of Japan and/or the country of destination is prohibited.
8. Please contact Renesas Technology Corp. for further details on these materials or the products contained therein.



# Contents

Section 1	Connecting the Emulator with the User System .....	1
1.1	Components of the Emulator.....	1
1.2	Connecting the E10A Emulator with the User System .....	4
1.3	Installing the H-UDI Port Connector on the User System .....	5
1.4	Pin Assignments of the H-UDI Port Connector.....	5
1.5	Recommended Circuit between the H-UDI Port Connector and the MCU .....	8
1.5.1	Recommended Circuit (36-Pin Type).....	8
1.5.2	Recommended Circuit (14-Pin Type).....	11
Section 2	Specifications of the SH7144F E10A Emulator's Software.....	13
2.1	Differences between the SH7144F, SH7145F, and the Emulator .....	13
2.2	Specific Functions for the SH7144F E10A Emulator .....	18
2.2.1	Emulator Driver Selection .....	18
2.2.2	Break Condition Functions .....	19
2.2.3	AUD Functions.....	21
2.2.4	Notes on Displaying the [Trace] Window .....	23
2.2.5	Notes on Using the JTAG Clock (TCK).....	23
2.2.6	Notes on Setting the [Breakpoint] Dialog Box .....	24



# Section 1 Connecting the Emulator with the User System

## 1.1 Components of the Emulator

The E10A emulator supports the SH7144F and SH7145F.

The supported operating modes are as follows:

- MCU expansion mode 2
- Single-chip mode

Table 1.1 lists the components of the emulator.

**Table 1.1 Components of the Emulator (HS7144KCM01H, HS7144KCM02H, HS7144KCI01H, or HS7144KCI02H)**

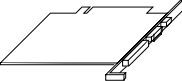
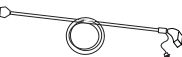
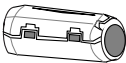
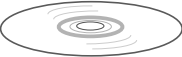
Classification	Component	Appearance	Quantity	Remarks
Hardware	Card emulator	 (PCMCIA)	1	HS7144KCM01H (PCMCIA: 14-pin type): Depth: 85.6 mm, Width: 54.0 mm, Height: 5.0 mm, Mass: 27.0 g HS7144KCM02H (PCMCIA: 36-pin type): Depth: 85.6 mm, Width: 54.0 mm, Height: 5.0 mm, Mass: 28.0 g HS7144KCI01H (PCI: 14-pin type): Depth: 122.0 mm, Width: 96.0 mm, Mass: 80.0 g HS7144KCI02H (PCI: 36-pin type): Depth: 122.0 mm, Width: 96.0 mm, Mass: 90.0 g
		 (PCI)		
	User system interface cable		1	HS7144KCM01H (PCMCIA: 14-pin type): Length: 80 cm, Mass: 45.0 g HS7144KCM02H (PCMCIA: 36-pin type): Length: 30 cm, Mass: 55.0 g HS7144KCI01H (PCI: 14-pin type): Length: 150 cm, Mass: 86.0 g HS7144KCI02H (PCI: 36-pin type): Length: 80 cm, Mass: 69.0 g
	Ferrite core (connected with the user interface cable)		1	Countermeasure for EMI* (only for HS7144KCM02H and HS7144KCI02H)
Software	SH7144 E10A emulator setup program, SuperH™ Family E10A Emulator User's Manual, and Specific Guide for the SH7144F E10A Emulator		1	HS7144KCM01SR,  HS0005KCM01HJ, HS0005KCM01HE,  HS7144KCM02HJ, and HS7144KCM02HE (provided on a CD-R)

Note: The EMI is an abbreviation of the Electrical Magnetic Interference.

For EMI countermeasure, use the ferrite core by connecting the user interface cable. When the user interface cable is connected with the emulator or user system, connect the ferrite core in the user system as shown in figure 1.1.

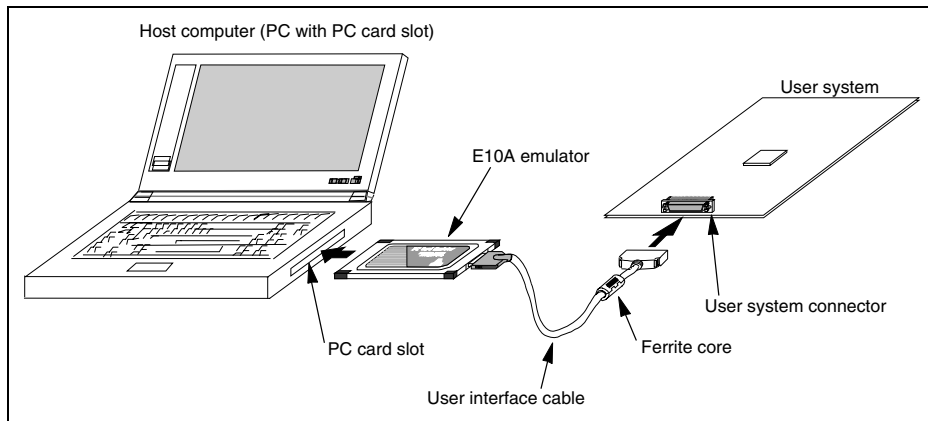

**Figure 1.1 Connecting Ferrite Core**

## 1.2 Connecting the E10A Emulator with the User System

To connect the E10A emulator (hereinafter referred to as the emulator), the H-UDI port connector must be installed on the user system to connect the user system interface cable. When designing the user system, refer to the recommended circuit between the H-UDI port connector and the MCU. In addition, read the E10A emulator user's manual and hardware manual for the related device.

Table 1.2 shows the type number of the emulator, the corresponding connector type, and the use of AUD function.

**Table 1.2 Type Number, AUD Function, and Connector Type**

Type Number	Connector	AUD Function
HS7144KCM02H, HS7144KCI02H	36-pin connector	Available
HS7144KCM01H, HS7144KCI01H	14-pin connector	Not available

The H-UDI port connector has the 36-pin and 14-pin types as described below. Use them according to the purpose of the usage.

1. 36-pin type (with AUD function)

The AUD trace function is supported. A large amount of trace information can be acquired in realtime. The window trace function is also supported for acquiring memory access in the specified range (memory access address or memory access data) by tracing.

2. 14-pin type (without AUD function)

The AUD trace function cannot be used because only the H-UDI function is supported. For tracing, only the internal trace function is supported. Since the 14-pin type connector is smaller than the 36-pin type (1/2.5), the area where the connector is installed on the user system can be reduced.

### 1.3 Installing the H-UDI Port Connector on the User System

Table 1.3 shows the recommended H-UDI port connectors for the emulator.

**Table 1.3 Recommended H-UDI Port Connectors**

Connector	Type Number	Manufacturer	Specifications
36-pin connector	DX10M-36S	Hirose Electric Co., Ltd.	Screw type
	DX10M-36SE, DX10G1M-36SE		Lock-pin type
14-pin connector	2514-6002	Minnesota Mining & Manufacturing Ltd.	14-pin straight type

Note: When designing the 14-pin connector layout on the user board, do not place any components within 3 mm of the H-UDI port connector. When designing the 36-pin connector layout on the user board, do not connect any components under the H-UDI connector.

### 1.4 Pin Assignments of the H-UDI Port Connector

Figures 1.2 and 1.3 show the pin assignments of the 36-pin and 14-pin H-UDI port connectors, respectively.

Note: Note that the pin number assignments of the H-UDI port connector shown on the following pages differ from those of the connector manufacturer.

Pin No.	Signal	Input/ Output*1	SH7144F Pin No.	SH7145F Pin No.	Note	Pin No.	Signal	Input/ Output*1	SH7144F Pin No.	SH7145F Pin No.	Note
1	AUDCK	I/O	53	65		19	TMS	Input	85	138	
2	GND	—				20	GND	—			
3	AUDATA0	I/O	60	72		21 <sup>2</sup>	/TRST	Input	86	139	
4	GND	—				22	GND	—			
5	AUDATA1	I/O	59	70		23	TDI	Input	87	140	
6	GND	—				24	GND	—			
7	AUDATA2	I/O	58	69		25	TDO	Output	88	142	
8	GND	—				26	GND	—			
9	AUDATA3	I/O	57	68		27 <sup>2</sup>	/ASEBRKAK	Output	27	35	
10	GND	—				28	GND	—			
11 <sup>2</sup>	/AUDSYNC	I/O	52	64		29	CK	Output	83	107	
12	GND	—				30	GND	—			
13 <sup>2</sup>	/AUDRST	Input	56	67		31 <sup>2</sup>	/RES	Output	84	108	User reset
14	GND	—				32	GND	—			
15	AUDMD	Input	54	66		33 <sup>3</sup>	GND	Output			
16	GND	—				34	GND	—			
17	TCK	Input	89	143		35	NC	—			
18	GND	—				36	GND	—			

Notes: 1. Input to or output from the user system.

2. The slash (/) means that the signal is active-low.

3. The emulator monitors the GND signal of the user system and detects whether or not the user system is connected.

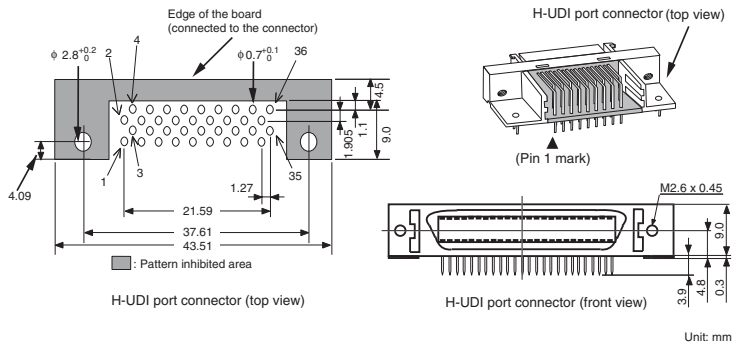

**Figure 1.2 Pin Assignments of the H-UDI Port Connector (36 Pins)**

#### Limitation:

The AUD pins of the SH7145F are also multiplexed to port E. However, do not use those pins when the AUD function is used by the emulator. The correct address or data will not be accessed.

Pin No.	Signal	Input/ Output* 1	SH7144F Pin No.	SH7145F Pin No.
1	TCK	Input	89	143
2*2	/TRST	Input	86	139
3	TDO	Output	88	142
4*2	/ASEBRKAK	Output	27	35
5	TMS	Input	85	138
6	TDI	Input	87	140
7*2	/RES	Output	84	108
11	N.C.	—	—	—
8 to 10 and 12 to 13	GND	—	—	—
14*3	GND	Output	—	—

- Notes: 1. Input to or output from the user system.  
2. The slash (/) means that the signal is active-low.  
3. The emulator monitors the GND signal of the user system and detects whether or not the user system is connected.

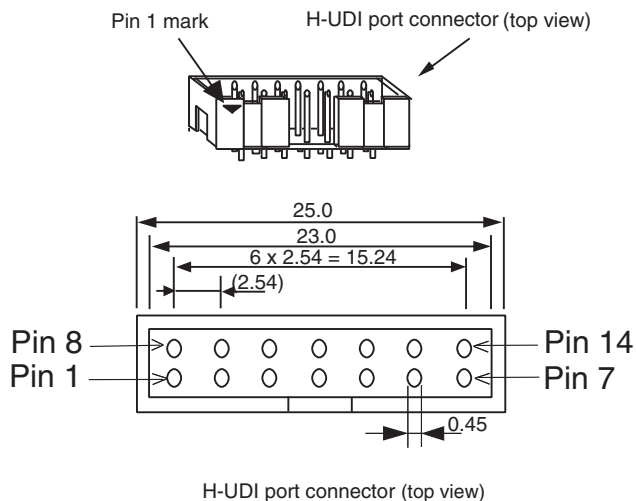

Figure 1.3 Pin Assignments of the H-UDI Port Connector (14 Pins)

## 1.5 Recommended Circuit between the H-UDI Port Connector and the MCU

### 1.5.1 Recommended Circuit (36-Pin Type)

Figure 1.5 shows a recommended circuit between the H-UDI port connector (36 pins) and the MCU.

- Notes:
1. Do not connect anything to the N.C. pins of the H-UDI port connector.
  2. When a network resistance is used for pull-up, it may be affected by a noise. Separate TCK from other resistances.
  3. The reset signal in the user system is input to the /RES pin (SH7144F: pin 84, SH7145F: pin 108). Connect this signal to the H-UDI port connector as the output from the user system.
  4. When the emulator is used, the AUDCK pin must be an end resistance (pulled up or down by a resistance of several kilo-ohms) because it may be affected by a reflected noise from the user system interface cable.
  5. When the emulator is used, connect the CK pin between the H-UDI port connector and the MCU via a buffer (74LVC125 is recommended) as shown in figure 4.1.
  6. Note that the processing of the DBGMD pin (SH7144F: pin 33, SH7145F: pin 42) differs depending on whether or not the emulator is used. In addition, the DBGMD pin must be switched on the board because it is not controlled by the emulator.
    - (1) When the emulator is used: DBGMD = high
    - (2) When the emulator is not used: DBGMD = low
  7. The resistance values shown in figure 1.5 are recommended.
  8. The pattern between the H-UDI port connector and the MCU must be as short as possible. Do not connect the signal lines to other components on the board.
  9. When the power of the emulator is turned on (make sure that the emulator is inserted into the host computer and the power supply is turned on), and the target system (such as the system mounting the target device) is turned off, the power-supply voltage of the target device (target system) may become higher around 1.2 V to 1.4 V than the normal voltage due to the leakage current from the emulator. This is because TMS and TRST are driven to high by the emulator; the leakage current occurs from a TMS line before starting the emulator debugger (HEW), and from TMS and TRST lines through the CPU after starting the emulator debugger. Although the CPU will not be degraded or damaged, a power-on reset may be disabled. The power-supply voltage raised by the leakage current can be reduced to 0.2 V by inserting a diode in the output pins (TMS and TRST) of the emulator. For the type (type number) and the inserting direction of the diode, see figure 1.4.

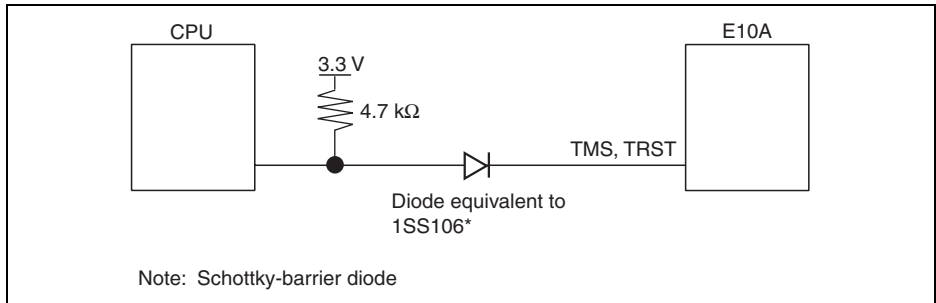

**Figure 1.4 Countermeasure against the Leakage Current in the Emulator**

The result above differs depending on the circuit and can only be used as a reference.

10. For the pin processing when the emulator is not used, refer to the hardware manual of the related MCU.

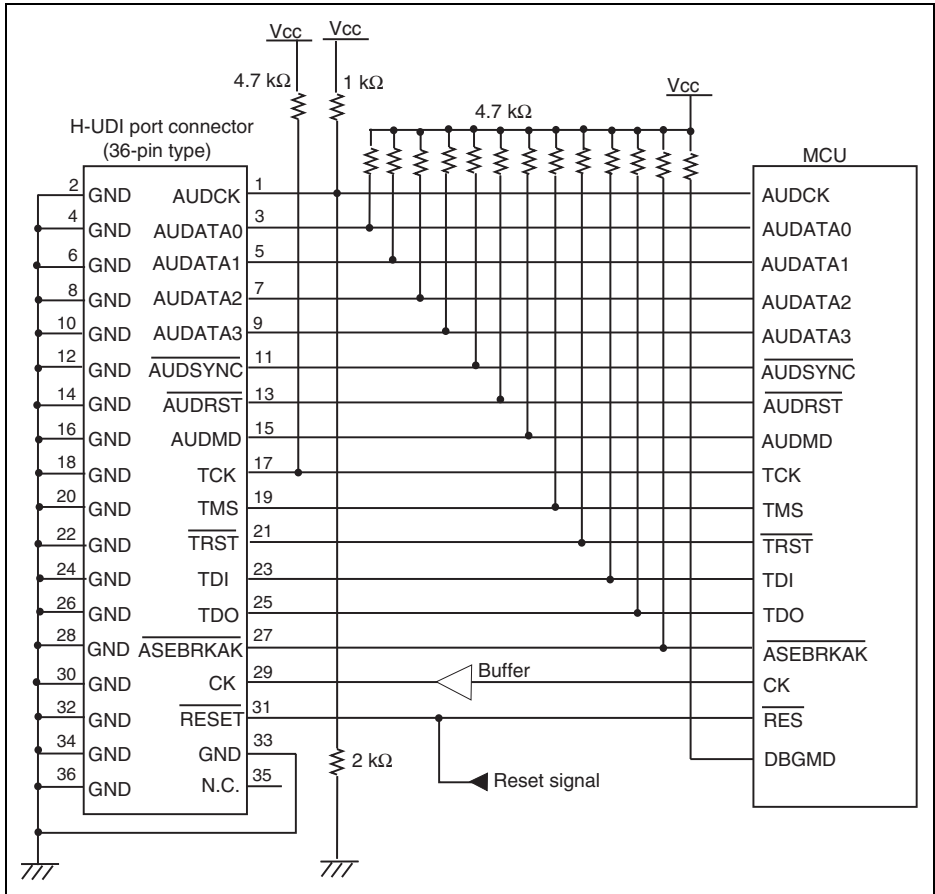
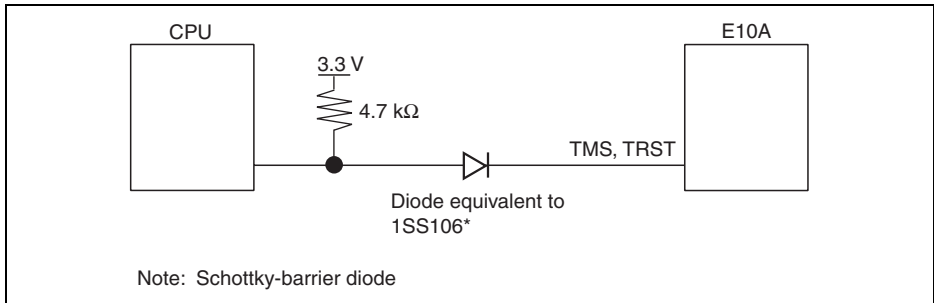

**Figure 1.5 Recommended Circuit for Connection between the H-UDI Port Connector and the MCU (36-Pin Type)**

## 1.5.2 Recommended Circuit (14-Pin Type)

Figure 1.7 shows a recommended circuit between the H-UDI port connector (14 pins) and the MCU.

- Notes:
1. Do not connect anything to the N.C. pins of the H-UDI port connector.
  2. The reset signal in the user system is input to the /RES pin (SH7144F: pin 84, SH7145F: pin 108). Connect this signal to the H-UDI port connector as the output from the user system.
  3. Note that the processing of the DBGMD pin (SH7144F: pin 33, SH7145F: pin 42) differs whether or not the emulator is used. In addition, the DBGMD pin must be switched on the board because it is not controlled by the emulator.
    - (1) When the emulator is used: DBGMD = high
    - (2) When the emulator is not used: DBGMD = low
  4. When a network resistance is used for pull-up, it may be affected by a noise. Separate TCK from other resistances.
  5. The resistance values shown in figure 1.7 are recommended.
  6. The pattern between the H-UDI port connector and the MCU must be as short as possible. Do not connect the signal lines to other components on the board.
  7. When the power of the emulator is turned on (make sure that the emulator is inserted into the host computer and the power supply is turned on), and the target system (such as the system mounting the target device) is turned off, the power-supply voltage of the target device (target system) may become higher around 1.2 V to 1.4 V than the normal voltage due to the leakage current from the emulator. This is because TMS and TRST are driven to high by the emulator; the leakage current occurs from a TMS line before starting the emulator debugger (HEW), and from TMS and TRST lines through the CPU after starting the emulator debugger. Although the CPU will not be degraded or damaged, a power-on reset may be disabled. The power-supply voltage raised by the leakage current can be reduced to 0.2 V by inserting a diode in the output pins (TMS and TRST) of the emulator. For the type (type number) and the inserting direction of the diode, see figure 1.6.



**Figure 1.6 Countermeasure against the Leakage Current in the Emulator**

The result above differs depending on the circuit and can only be used as a reference.

8. For the pin processing when the emulator is not used, refer to the hardware manual of the related MCU.

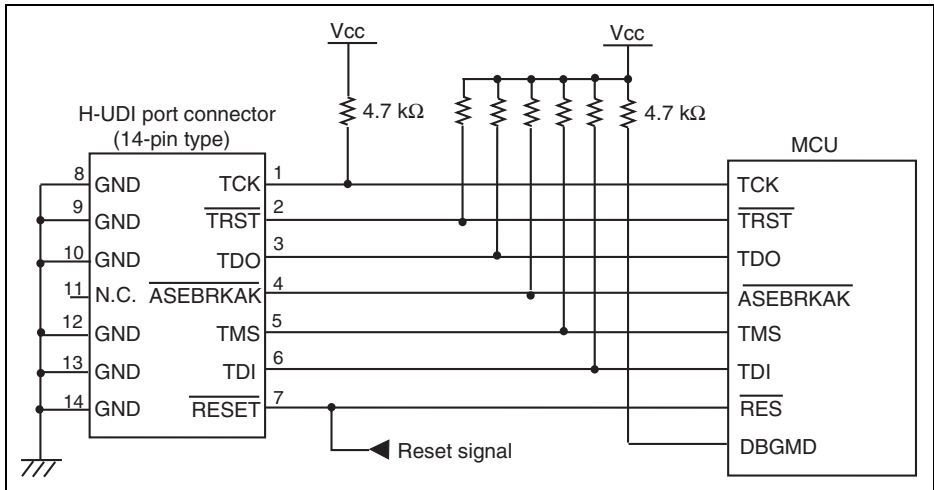

**Figure 1.7 Recommended Circuit for Connection between the H-UDI Port Connector and the MCU (14-Pin Type)**

## Section 2 Specifications of the SH7144F E10A Emulator's Software

### 2.1 Differences between the SH7144F, SH7145F, and the Emulator

1. When the emulator system is initiated, it initializes the general registers and part of the control registers as shown in table 2.1. The initial values of the actual SH7144F or SH7145F registers are undefined. When the emulator is initiated from the workspace, a value to be entered is saved in a session.

**Table 2.1 Register Initial Values at Emulator Link Up**

Register	Emulator at Link Up
R0 to R14	H'00000000
R15 (SP)	Value of the SP in the vector address table
PC	Value of the PC in the vector address table
SR	H'000000F0
GBR	H'00000000
VBR	H'00000000
MACH	H'00000000
MACL	H'00000000
PR	H'00000000

2. The emulator uses the H-UDI; do not access the H-UDI.
3. Low-Power States (Sleep, Software Standby, and Module Standby)

For low-power consumption, the SH7144F or SH7145 has sleep, software standby, and module standby states.

When the emulator is used, the sleep mode can be cleared with either the normal clearing function or with the forced break. Note that, however, if a command has been entered in software standby mode or module standby mode, no commands can be used from the emulator since the mode is cleared only with the normal clearing function.

Notes: The memory must not be accessed or modified in sleep state.

1. Do not set the MSTP2 or MSTP27 bit to 1 in the MSTCR2 register (address H'FFFF861E) nor the RAME bit to 0 in the SYSCR register (address H'FFFF8618), since doing so may prevent the emulator from operating correctly.
2. When the HS7144KCM02H or HS7144KCI02H is used, do not set the following bits to 0: the MSTP3 bit in the MSTCR2 register (address H'FFFF861E) and the AUDSRST bit in the SYSCR register (address H'FFFF8618). The AUD function cannot be used.

#### 4. Reset Signals (/RES)

The RESET signal can be accepted during user program break, when the peripheral modules are reset. Since the PC, SR, and SP registers are not initialized, reset them and execute the GO command when the user program is executed from the reset vector.

Note: Do not break the user program when the /RES, /BREQ, or /WAIT pin is being low. A TIMEOUT error will occur. The TIMEOUT error will also occur at memory access when the /BREQ or /WAIT pin is fixed low during break.

#### 5. Data Transfer Controller (DTC)

The DTC operates even in the command wait state. When a data transfer request is generated, the DTC executes a DMA transfer.

#### 6. Memory Access during User Program Execution

When a memory is accessed from the memory window, etc. during user program execution, the user program is resumed after it has stopped in the emulator to access the memory.

Therefore, realtime emulation cannot be performed.

The stopping time of the user program is as follows:

Environment:

Host computer: 650 MHz (Pentium® III)

OS: Windows® 2000

SH7144F: 50 MHz (CPU clock)

JTAG clock: 3.75 MHz (TCK clock)

When a one-byte memory is read from the command-line window, the stopping time will be about 40 ms.

#### 7. Memory Access during User Program Break

Memory write operations are enabled for the RAM area and the internal flash memory.

Therefore, an operation such as memory write or BREAKPOINT should be set only for the RAM area and the internal flash memory.

## 8. Multiplexed Functions

The AUD and H-UDI pins are multiplexed as shown in tables 2.2 and 2.3. Those functions cannot be used when the emulator is used.

**Table 2.2 Multiplexed Functions for the SH7144F**

<b>Function 1</b>	<b>Function 2</b>
PE0/TIOC0A/DREQ0	TMS (H-UDI)
PE1/TIOC0B/DRAK0	TRST (H-UDI)
PE2/TIOC0C/DREQ1	TDI (H-UDI)
PE3/TIOC0D/DRAK1	TDO (H-UDI)
PE4/TIOC1A/RXD3	TCK (H-UDI)
PD15/D15*	AUDSYNC (AUD)
PD14/D14*	AUDCK (AUD)
PD13/D13*	AUDMD (AUD)
PD12/D12*	AUDRST (AUD)
PD11/D11*	AUDATA3 (AUD)
PD10/D10*	AUDATA2 (AUD)
PD9/D9*	AUDATA1 (AUD)
PD8/D8*	AUDATA0 (AUD)
PA15*	CK (AUD)

Note: Function 1 can be used when the AUD pins of the MCU are not connected to the emulator.

**Table 2.3 Multiplexed Functions for the SH7145F**

<b>Function 1</b>	<b>Function 2</b>
PE9/TIOC3B/SCK3	TRST (H-UDI)
PE8/TIOC3A/SCK2	TMS (H-UDI)
PE11/TIOC3D/RXD3	TDO (H-UDI)
PE10/TIOC3C/TXD2	TDI (H-UDI)
PE12/TIOC4A/TXD3	TCK (H-UDI)
PA15*	CK (AUD)
PD23/D23/IRQ7*	AUDSYNC (AUD)
PD22/D22/IRQ6*	AUDCK (AUD)
PD21/D21/IRQ5*	AUDMD (AUD)
PD20/D20/IRQ4*	AUDRST (AUD)
PD19/D19/IRQ3*	AUDATA3 (AUD)
PD18/D18/IRQ2*	AUDATA2 (AUD)
PD17/D17/IRQ1*	AUDATA1 (AUD)
PD16/D16/IRQ0*	AUDATA0 (AUD)

Note: Function 1 can be used when the AUD pins of the MCU are not connected to the emulator. The AUD pins of the SH7145F are also multiplexed to port E. However, do not use those pins when the AUD function is used by the emulator. The correct address or data will not be accessed.

## 9. Loading Sessions

Information in [JTAG clock] of the [Configuration] dialog box cannot be recovered by loading sessions. Thus the TCK value will be as follows:

- When HS7144KCI01H or HS7144KCI02H is used: TCK = 4.125 MHz
- When HS7144KCM01H or HS7144KCM02H is used: TCK = 3.75 MHz

## 10. [IO] Window

- Display and modification

For each Watchdog Timer register, there are two registers to be separately used for write and read operations.

**Table 2.4 Watchdog Timer Registers**

Register Name	Usage	Register
TCSR (R)	Read	Watchdog timer control/status register
TCNT (R)	Read	Watchdog timer counter
RSTCSR (R)	Read	Reset control/status register
TCSR (W)	Write	Watchdog timer control/status register
TCNT (W)	Write	Watchdog timer counter
RSTCSR (W)	Write	Reset control/status register

- The internal I/O registers can be accessed from the [IO] window. After the I/O-register definition file is created, the MCU's specification may be changed. If each I/O register in the I/O-register definition file differs from addresses described in the hardware manual, change the I/O-register definition file according to the description in the hardware manual. The I/O-register definition file can be customized depending on its format. Note that, however, the emulator does not support the bit-field function.
- Verify  
In the [IO] window, the verify function of the input value is disabled.

## 11. Illegal Instructions

If illegal instructions are executed by STEP-type commands, the emulator cannot go to the next program counter.

## 12. Interrupts

All interrupts except for NMI are masked during user program break.

## 13. When accessing the reserved memory area, use the [Memory] window; do not use other windows.

## 14. Processing Time for Updating the Flash Memory Contents

When the contents of the flash memory area is modified by the program loading, memory window, or memory command, or when a software break is set, a waiting time will be generated to write or read the flash memory before executing the user program.

The processing time for updating the flash memory contents will be about a maximum of 60 seconds under the following environments (reference values):

- Host computer: 500 MHz (Pentium® III)
- SH7144F: 40 MHz (system clock frequency)

## 2.2 Specific Functions for the SH7144F E10A Emulator

The SH7144F or SH7145F does not support the following functions:

- MMU-related functions (The SH7144F or SH7145F does not mount the MMU.)
  - VPMAP-related command
  - Virtual and Physical specification in the [Configuration] window
  - Virtual and Physical specification on the command-line function
  - Virtual and Physical specification in the [Breakpoint] window
  - LDTLB instruction execution break function
  - MEMORYAREA\_SET command
- Internal I/O access break function
- UBC\_MODE command (The UBC function cannot be used while the emulator is being used.)
- UBC\_MODE specification in the [Configuration] window or the command-line function
- Profiling function
- Performance measurement function

### 2.2.1 Emulator Driver Selection

Table 2.5 shows drivers which are selected in the [E10A Driver Details] dialog box.

**Table 2.5 Type Number and Driver**

Type Number	Driver
HS7144KCM01H	E10A PC Card Driver 3
HS7144KCM02H	E10A PCI Card Driver 3
HS7144KCI01H	E10A PC Card Driver 4
HS7144KCI02H	E10A PCI Card Driver 4

## 2.2.2 Break Condition Functions

The emulator can set conditions of Break Condition. Table 2.6 lists these conditions.

**Table 2.6 Types of Break Conditions**

Items	Description
Address bus condition (Address)	Breaks when the MCU address bus value or program counter value matches the specified value.
Data size condition (Size)	Breaks when the data size that has been accessed matches the specified value. Byte, word, or longword can be specified as the access data size.
Read or write condition (Read or Write)	Breaks in the read or write cycle.
Access type	Breaks when the bus cycle is the specified cycle.

Table 2.7 lists the combinations of conditions that can be set in the [Break Condition] dialog box.

**Table 2.7 Conditions Set in the [Break Condition] Dialog Box**

Dialog Box	Type	
	Address Bus Condition ([Address] page)	Access Type Condition, Read or Write Condition, Data Size Condition ([Bus state] page)
[Break Condition 1] dialog box	<input type="radio"/>	<input type="radio"/>
[Break Condition 2] dialog box	<input type="radio"/>	<input type="radio"/>
[Break Condition 3] dialog box	<input type="radio"/>	<input type="radio"/>
[Break Condition 4] dialog box	<input type="radio"/>	<input type="radio"/>
[Break Condition R] dialog box	<input type="radio"/>	-

Note: : Can be set by clicking the radio button in the dialog box.

Table 2.8 lists the combinations of conditions that can be set with the BREAKCONDITION\_SET command.

**Table 2.8 Conditions Set with the BREAKCONDITION\_SET Command**

Channel	Type	
	Address Bus Condition (<addropt> option)	Access Type Condition (<accessopt> option), Read or Write Condition (<r/wopt> option), Data Size Condition (<sizeopt> option)
Break Condition 1	○	○
Break Condition 2	○	○
Break Condition 3	○	○
Break Condition 4	○	○
Break Condition R	○	-

Note: ○: Can be set by the BREAKCONDITION\_SET command.

**Notes on Setting the [Break Condition] Dialog Box and BREAKCONDITION\_SET Command:**

1. When [Go to cursor], [Step In], [Step Over], or [Step Out] is selected, the settings of Break Condition 3 are disabled.
2. Break Condition 3 is disabled when an instruction to which a BREAKPOINT has been set is executed. Accordingly, do not set a BREAKPOINT to an instruction which satisfies Break Condition 3.
3. When a Break Condition is satisfied, emulation may stop after two or more instructions have been executed.
4. If a PC break before execution is set to the slot instruction after a delayed branch instruction, user program execution cannot be terminated before the slot instruction execution; execution stops before the branch destination instruction.

### 2.2.3 AUD Functions

In the emulator, the functions listed in table 2.9 using the AUD function can be used. These functions are operational when the AUD pin is connected to the emulator.

To enable the AUD function, select [Options -> Emulator -> System...] or set [AUD used] in the [AUD Port] combo box of the [Configuration] dialog box that is opened by clicking the [Emulator System] toolbar button .

Note: Select [AUD used] and set the following before using the AUD function in the user program. The AUD function does not operate correctly until the following is set after user program execution is started:

- Set 1 to the AUDSRST bit in the SYSCR register and cancel the AUD reset.
- Set the pin function controller to enable the AUD input/output pins (/AUDSYNC, AUDCK, AUDMD, /AUDRST, AUDATA3, AUDATA2, AUDATA1, and AUDATA0) and the CK pin.

**Table 2.9 AUD Functions**

Function	Description
Branch trace function	Displays the addresses and instruction words at the branch destination.
RAM monitor function	Enables realtime memory reading or writing during user program execution.

- Notes: 1. When HS7144KCI01H or HS7144KCM01H is used, the AUD function cannot be used.  
2. When the MCU operating mode is MCU expansion mode 2, the AUD function cannot be used.

Limitation:

The AUD pins of the SH7145F are multiplexed to ports D and E. However, do not use those pins that are multiplexed to port E when the AUD function is used by the emulator. The correct address or data will not be accessed.

#### (1) Branch Trace Function

When a branch occurs during user program execution, the branch destination address is acquired. When the next branch occurs while the trace information is being output, the information is stopped and the next trace information is output. The user program can be executed in realtime, but some trace information will not be output.

Note: After [Trace stop] is selected in [AUD mode] of the [Trace mode] page in the [Trace Acquisition] dialog box and the trace buffer of the emulator becomes full, the trace information is not acquired. The user program is continuously executed.

## (2) Realtime Memory Access Function

Realtime memory reading or writing is enabled during user program execution. The specified memory address contents (maximum three) can be displayed on the status bar. The memory contents can be changed by the command line, and can be referenced in the [Memory] window.

Memory can be read or written as follows:

1. When the [Memory] window is used:

Memory can be read or written during user program execution. Open the address to be referenced in the [Memory] window. At reference, select Refresh from the [Memory] menu or issue the Refresh command in the command-line window.

2. When the command line is used:

MEMORY\_EDIT command: Memory can be read or written during user program execution.

RAM\_R command: Address and size displayed on the status bar are specified during user program execution.

RAM\_W command: Memory can be changed during user program execution. One command can change a maximum of three addresses.

Note: Note that the flash memory area cannot be written by the RAM\_W command.

## (3) Products Using the AUD Function and Note

**Table 2.10** Type Number and AUD Function

Type Number	Connector	AUD Function
HS7144KCM02H, HS7144KCI02H	36-pin connector	Available
HS7144KCM01H, HS7144KCI01H	14-pin connector	Not available

Note: Trace cannot be acquired while memory read/write is being performed by using the RAM monitor function during user program execution.

## 2.2.4 Notes on Displaying the [Trace] Window

1. The AUD trace outputs the differences between newly output branch destination addresses and the previously output branch destination addresses. If the previous branch destination address is the same as the upper 16 bits, the lower 16 bits are output. If it matches the upper 24 bits, the lower 8 bits are output. If it matches the upper 28 bits, the lower 4 bits are output. The emulator regenerates the 32-bit address from these differences and usually displays it in the [Trace] window. If the emulator cannot display the 32-bit address, it displays the difference from the previously displayed 32-bit address.
2. When a completion-type exception occurs during exception branch acquisition, the next address to the address in which an exception occurs is acquired.
3. When the [Halt] option is used from the popup menu in the [Trace] window, realtime emulation is retained.
4. In the emulator, the maximum number of trace display pointers is as follows:  
When HS7144KCI02H is used: D'65535 to 0  
When HS7144KCM02H is used: D'16383 to 0  
However, the maximum number of trace display pointers differs according to the AUD trace information to be output. Therefore, the above pointers cannot be always acquired.
5. When only one line is acquired by trace, the display data is not updated. In this case, open the [Trace] window again.

## 2.2.5 Notes on Using the JTAG Clock (TCK)

1. When the JTAG clock (TCK) is used, set the frequency to lower than that of the system clock.
2. Do not set the following values for the JTAG clock (TCK):  
When HS7144KCM01H or HS7144KCM02H is used: 15 MHz  
When HS7144KCI01H or HS7144KCI02H is used: 16.5 MHz

## 2.2.6 Notes on Setting the [Breakpoint] Dialog Box

1. When an odd address is set, the address is rounded down to an even address.
2. A BREAKPOINT is accomplished by replacing instructions. Accordingly, it can be set only to the RAM area and the internal flash memory. However, a BREAKPOINT cannot be set to the following addresses:
  - An area other than the CS0, internal RAM, and internal flash memory areas
  - An instruction in which Break Condition 3 is satisfied
  - A slot instruction of a delayed branch instruction
3. During step execution, BREAKPOINTS are disabled.
4. Break Condition 3 is disabled when an instruction to which a BREAKPOINT has been set is executed. Accordingly, do not set a BREAKPOINT to an instruction which satisfies Break Condition 3.
5. When execution resumes from the address where a BREAKPOINT is specified, single-step operation is performed at the address before execution resumes. Therefore, realtime operation cannot be performed.
6. When a BREAKPOINT is set to the slot instruction of a delayed branch instruction, the PC value becomes an illegal value. Accordingly, do not set a BREAKPOINT to the slot instruction of a delayed branch instruction.
7. If an address of a BREAKPOINT cannot be correctly set in the ROM or flash memory area, a mark ● will be displayed in the [BP] area of the address on the [Editor] or [Disassembly] window by refreshing the [Memory] window, etc. after Go execution. However, no break will occur at this address. When the program halts with the break condition, the mark ● disappears.

---

**SuperH™ Family E10A Emulator**  
**Additional Document for User's Manual**  
**Specific Guide for the SH7144F E10A Emulator**

Publication Date: Rev.1.00, October 6, 2005  
Published by: Sales Strategic Planning Div.  
Renesas Technology Corp.  
Edited by: Customer Support Department  
Global Strategic Communication Div.  
Renesas Solutions Corp.

**Renesas Technology Corp.** Sales Strategic Planning Div. Nippon Bldg., 2-6-2, Ohte-machi, Chiyoda-ku, Tokyo 100-0004, Japan

---



## RENESAS SALES OFFICES

<http://www.renesas.com>

---

Refer to "<http://www.renesas.com/en/network>" for the latest and detailed information.

**Renesas Technology America, Inc.**

450 Holger Way, San Jose, CA 95134-1368, U.S.A  
Tel: <1> (408) 382-7500, Fax: <1> (408) 382-7501

**Renesas Technology Europe Limited**

Dukes Meadow, Millboard Road, Bourne End, Buckinghamshire, SL8 5FH, United Kingdom  
Tel: <44> (1628) 585-100, Fax: <44> (1628) 585-900

**Renesas Technology Hong Kong Ltd.**

7th Floor, North Tower, World Finance Centre, Harbour City, 1 Canton Road, Tsimshatsui, Kowloon, Hong Kong  
Tel: <852> 2265-6688, Fax: <852> 2730-6071

**Renesas Technology Taiwan Co., Ltd.**

10th Floor, No.99, Fushing North Road, Taipei, Taiwan  
Tel: <886> (2) 2715-2888, Fax: <886> (2) 2713-2999

**Renesas Technology (Shanghai) Co., Ltd.**

Unit2607 Ruijing Building, No.205 Maoming Road (S), Shanghai 200020, China  
Tel: <86> (21) 6472-1001, Fax: <86> (21) 6415-2952

**Renesas Technology Singapore Pte. Ltd.**

1 Harbour Front Avenue, #06-10, Keppel Bay Tower, Singapore 098632  
Tel: <65> 6213-0200, Fax: <65> 6278-8001

**Renesas Technology Korea Co., Ltd.**

Kukje Center Bldg. 18th Fl., 191, 2-ka, Hangang-ro, Yongsan-ku, Seoul 140-702, Korea  
Tel: <82> 2-796-3115, Fax: <82> 2-796-2145

**Renesas Technology Malaysia Sdn. Bhd.**

Unit 906, Block B, Menara Amcorp, Amcorp Trade Centre, No.18, Jalan Persiaran Barat, 46050 Petaling Jaya, Selangor Darul Ehsan, Malaysia  
Tel: <603> 7955-9390, Fax: <603> 7955-9510

**SuperH™ Family E10A Emulator  
Additional Document for User's Manual  
Specific Guide for the SH7144F/SH7145F E10A  
Emulator**



**Renesas Electronics Corporation**

1753, Shimonumabe, Nakahara-ku, Kawasaki-shi, Kanagawa 211-8668 Japan

REJ10J1017-0100