

To our customers,

Old Company Name in Catalogs and Other Documents

On April 1st, 2010, NEC Electronics Corporation merged with Renesas Technology Corporation, and Renesas Electronics Corporation took over all the business of both companies. Therefore, although the old company name remains in this document, it is a valid Renesas Electronics document. We appreciate your understanding.

Renesas Electronics website: <http://www.renesas.com>

April 1st, 2010
Renesas Electronics Corporation

Issued by: Renesas Electronics Corporation (<http://www.renesas.com>)

Send any inquiries to <http://www.renesas.com/inquiry>.

Notice

1. All information included in this document is current as of the date this document is issued. Such information, however, is subject to change without any prior notice. Before purchasing or using any Renesas Electronics products listed herein, please confirm the latest product information with a Renesas Electronics sales office. Also, please pay regular and careful attention to additional and different information to be disclosed by Renesas Electronics such as that disclosed through our website.
2. Renesas Electronics does not assume any liability for infringement of patents, copyrights, or other intellectual property rights of third parties by or arising from the use of Renesas Electronics products or technical information described in this document. No license, express, implied or otherwise, is granted hereby under any patents, copyrights or other intellectual property rights of Renesas Electronics or others.
3. You should not alter, modify, copy, or otherwise misappropriate any Renesas Electronics product, whether in whole or in part.
4. Descriptions of circuits, software and other related information in this document are provided only to illustrate the operation of semiconductor products and application examples. You are fully responsible for the incorporation of these circuits, software, and information in the design of your equipment. Renesas Electronics assumes no responsibility for any losses incurred by you or third parties arising from the use of these circuits, software, or information.
5. When exporting the products or technology described in this document, you should comply with the applicable export control laws and regulations and follow the procedures required by such laws and regulations. You should not use Renesas Electronics products or the technology described in this document for any purpose relating to military applications or use by the military, including but not limited to the development of weapons of mass destruction. Renesas Electronics products and technology may not be used for or incorporated into any products or systems whose manufacture, use, or sale is prohibited under any applicable domestic or foreign laws or regulations.
6. Renesas Electronics has used reasonable care in preparing the information included in this document, but Renesas Electronics does not warrant that such information is error free. Renesas Electronics assumes no liability whatsoever for any damages incurred by you resulting from errors in or omissions from the information included herein.
7. Renesas Electronics products are classified according to the following three quality grades: “Standard”, “High Quality”, and “Specific”. The recommended applications for each Renesas Electronics product depends on the product’s quality grade, as indicated below. You must check the quality grade of each Renesas Electronics product before using it in a particular application. You may not use any Renesas Electronics product for any application categorized as “Specific” without the prior written consent of Renesas Electronics. Further, you may not use any Renesas Electronics product for any application for which it is not intended without the prior written consent of Renesas Electronics. Renesas Electronics shall not be in any way liable for any damages or losses incurred by you or third parties arising from the use of any Renesas Electronics product for an application categorized as “Specific” or for which the product is not intended where you have failed to obtain the prior written consent of Renesas Electronics. The quality grade of each Renesas Electronics product is “Standard” unless otherwise expressly specified in a Renesas Electronics data sheets or data books, etc.
 - “Standard”: Computers; office equipment; communications equipment; test and measurement equipment; audio and visual equipment; home electronic appliances; machine tools; personal electronic equipment; and industrial robots.
 - “High Quality”: Transportation equipment (automobiles, trains, ships, etc.); traffic control systems; anti-disaster systems; anti-crime systems; safety equipment; and medical equipment not specifically designed for life support.
 - “Specific”: Aircraft; aerospace equipment; submersible repeaters; nuclear reactor control systems; medical equipment or systems for life support (e.g. artificial life support devices or systems), surgical implantations, or healthcare intervention (e.g. excision, etc.), and any other applications or purposes that pose a direct threat to human life.
8. You should use the Renesas Electronics products described in this document within the range specified by Renesas Electronics, especially with respect to the maximum rating, operating supply voltage range, movement power voltage range, heat radiation characteristics, installation and other product characteristics. Renesas Electronics shall have no liability for malfunctions or damages arising out of the use of Renesas Electronics products beyond such specified ranges.
9. Although Renesas Electronics endeavors to improve the quality and reliability of its products, semiconductor products have specific characteristics such as the occurrence of failure at a certain rate and malfunctions under certain use conditions. Further, Renesas Electronics products are not subject to radiation resistance design. Please be sure to implement safety measures to guard them against the possibility of physical injury, and injury or damage caused by fire in the event of the failure of a Renesas Electronics product, such as safety design for hardware and software including but not limited to redundancy, fire control and malfunction prevention, appropriate treatment for aging degradation or any other appropriate measures. Because the evaluation of microcomputer software alone is very difficult, please evaluate the safety of the final products or system manufactured by you.
10. Please contact a Renesas Electronics sales office for details as to environmental matters such as the environmental compatibility of each Renesas Electronics product. Please use Renesas Electronics products in compliance with all applicable laws and regulations that regulate the inclusion or use of controlled substances, including without limitation, the EU RoHS Directive. Renesas Electronics assumes no liability for damages or losses occurring as a result of your noncompliance with applicable laws and regulations.
11. This document may not be reproduced or duplicated, in any form, in whole or in part, without prior written consent of Renesas Electronics.
12. Please contact a Renesas Electronics sales office if you have any questions regarding the information contained in this document or Renesas Electronics products, or if you have any other inquiries.

(Note 1) “Renesas Electronics” as used in this document means Renesas Electronics Corporation and also includes its majority-owned subsidiaries.

(Note 2) “Renesas Electronics product(s)” means any product developed or manufactured by or for Renesas Electronics.

38D2 Group HP Package IC Socket Board

R0K3038D2Z010BR

Release Note, 1.00 Edition

Renesas Solutions Corp.
Nov 20, 2006

Thank you for purchasing the 38D2 Group IC socket board (R0K3038D2Z010BR).
This release note explains how to use. Please be sure to read it before using your IC socket board.

(Table of Contents)

1. Preface	2
2. Precautions (Be sure to read).....	2
3. Product Overview	2
4. Product Specifications	3
5. Package Information	3
6. IC Socket Board.....	4
6.1. External Specifications.....	4
6.2. External Power Supply Specifications	4
6.3. Jumper Specifications.....	4
6.4. Connector Specifications.....	5
7.1. Set Up (Programming on the IC socket board).....	6
7.2. Set Up (Programming on user target board)	6
7.3. Connection of user target board	7
8. Latest Information	7

1. Preface

This release note describes precautions and how to use the hardware included in the R0K3038D2Z010BR.

2. Precautions (Be sure to read)

[Remove MCU]

When removing a microcomputer from the IC socket, in use of the IC socket board (R0K3038D2Z010BR), Please remove the MCU after turning the power OFF.

[Connect E8]

Please connect the communication connector of E8 to CN1 of the IC socket board (R0K3038D2Z010BR). Do not connect E8 to CN2 of the IC socket board. When connecting E8 to CN2 and using the IC socket board, the microcomputer and E8 may be damaged.

[Potential Meter]

Do not turn the volume (VR1) of the IC socket board (R0K3038D2Z010BR). When turning the volume (VR1), and then using the IC socket board, programming to QzROM may not be performed properly. Also, the MCU may be damaged.

3. Product Overview

The 38D2 Group IC socket board (R0K3038D2Z010BR) is an IC socket board for programming to QzROM with Flash Development tool Kit (FDT) and E8.

[Applicable Microcomputer]

38D2 Group 64-Pin Version QzROM Microcomputer (Package : PLQP0064KB-A (64P6Q-A))

[Applicable Flash Writers]

(1) Renesas Technology Corp.

· Flash Development tool Kit (FDT)

URL:

http://america.renesas.com/fmwk.jsp?cnt=flash_development_toolkit_tools_product_landing.jsp&fp=/products/tools/flash_prom_programming/fdt/

· E8 (R0E000080KCE00)

URL:

http://www.renesas.com/fmwk.jsp?cnt=e8_tools_product_landing.jsp&fp=/Test_Demo/e8/

4. Product Specifications

Table 4-1 lists the Specifications of the IC socket board.

Table 4-1 Specifications

Item		R0K3038D2Z010BR
Operating Voltage	E8	3.3[V]±10% 5.0[V]±10%
	User Power Supply	2.7 to 5.5[V]
E8 power supply capability	3.3V±10%	<When external power for VPP generation is not used> Max. 50[mA] <When external power for VPP generation is used> Max. 300[mA]
	5.0V±10%	<When external power for VPP generation is not used> Max. 250[mA] <When external power for VPP generation is used> Max. 300[mA]
User Power Supply Current Consumption	3.3V±10%	<When external power for VPP generation is not used> Max. 250[mA] <When external power for VPP generation is used> Max. 10[mA]
	5.0V±10%	<When external power for VPP generation is not used> Max. 50[mA] <When external power for VPP generation is used> Max. 10[mA]
Power supply for VPP generation	Supply Voltage	9.0 to 12.0[V]
	Current Consumption	Max. 250[mA]
Operating Environment	Operating Ambient Temperature	25±5[°C]
	Humidity	No dew drops allowed

5. Package Information

Table 5-1 lists the Package Information of IC socket board.

Table 5-1 Package Information

Product Name	Quantity	Remark
IC Socket Board (R0K3038D2Z010BR)	1 pc	
Release Note	1 copy	In Japanese and English
User cable	1.pc	

6. IC Socket Board (R0K3038D2Z010BR)

6.1. External Specifications

Table 6-1 lists the External Specifications of IC socket board.

Table 6-1 External Specifications

Item	Description	Remark
Connector	[CN1] : Communication connector for connecting to E8	14-Pin Connector
	[CN2] : Communication connector for connecting to user board	14-Pin Connector
	[CN3] : Power supply connector for VPP power generation	
IC Socket	[IC4] : IC socket for PLQP0064KB-A (64P6Q-A))	LQFP
Oscillator	[X1] : 4MHz	
Jumper	[JP1] : Select MCU type	

6.2. External Power Supply Specifications

1) Power supply connector (CN3) for VPP power generation

The power supply connector (CN3) for VPP power generation is provided for the IC socket board.

Normally, the power is provided from E8 or the user board.

When drive capability of the power is not enough, external power for VPP generation of the IC socket board can be provided from the power connector.

The input voltage range of the external power for VPP power generation is 9.0 to 12.0V.

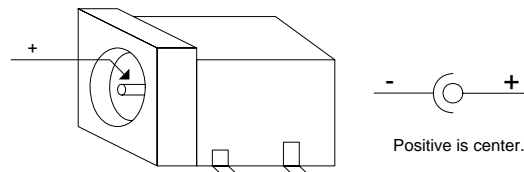

Figure 6.1 Power Supply for VPP power generation

6.3. Jumper Specifications

1) JP1

JP1 is used for selecting MCU type(QzROM/FLASH). Table 6-2 lists the JP1 Setting.

Set JP1 according to your MCU type.

Table 6-2 JP1 Setting

Jumper Setting	Description	Remark
FLASH	The MCU type is FLASH.	
QzROM	The MCU type is QzROM.	

6.4. Connector Specifications

- 1) CN1 : 14-pin connector for connection E8
Table 6-3 lists the CN1 Pin Assignment.

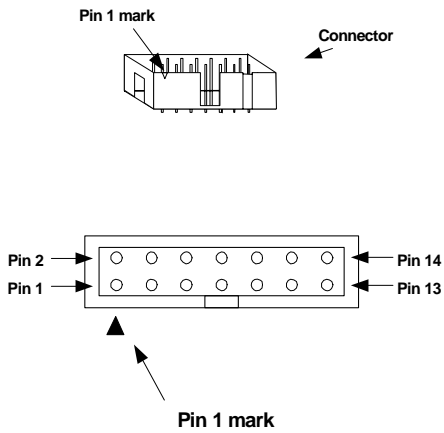

Figure 6.2 CN1 Pin Assignment

Refer) CN1

Product Name : 2.54mm Pitch 14-Pin Connector (Straight)

Part Number : 7614-6002

Manufacturer : SUMITOMO 3M Limited

Table 6-3 CN1 Pin Assignment

Pin No.	Signal Name
1	P31/SCLK2
2	VSS,AVSS
3	OSCSEL
4	P30/SRDY2
5	N.C.
6	VSS,AVSS
7	P32/TxD2
8	V _{cc}
9	P30/SRDY2
10	VSS,AVSS
11	P33/RxD2
12	VSS,AVSS
13	RESET
14	VSS,AVSS

- 2) CN2 : 14-pin connector for connection user board
Table 6-4 lists the CN2 pin Assignment.

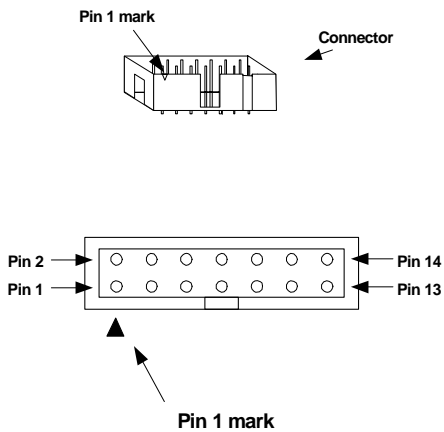

Figure 6.3 CN2 Pin Assignment

Refer) CN2

Product Name : 2.54mm Pitch 14-Pin Connector (Straight)

Part Number : 7614-6002

Manufacturer : SUMITOMO 3M Limited

Table 6-4 CN2 Pin Assignment

Pin No.	Signal Name	MCU Pin Name
1	P31/SCLK2	22
2	VSS,AVSS	11,61
3	OSCSEL	7
4	P30/SRDY2	23
5	N.C.	N.C.
6	VSS,AVSS	11,61
7	P32/TxD2	21
8	V _{cc}	16
9	N.C.	N.C.
10	VSS,AVSS	11,61
11	N.C.	N.C.
12	VSS,AVSS	11,61
13	RESET	8
14	VSS,AVSS	11,61

7. How to Use

7.1. Set Up (Programming on the IC socket board) : FLASH, QzROM

Procedure 1 Connect the connector CN1 to E8.

The set-up ends above.

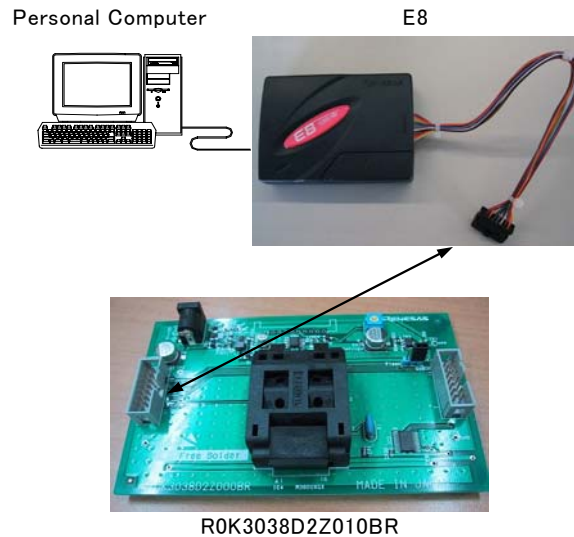

Figure 7.1 Connecting Example 1

7.2. Set Up (Programming on user target board) : QzROM

Procedure 1 When drive capability of the user target power is not enough, connect external power for VPP generation to R0K3038D2Z010BR.

*Since the R0K3038D2Z010BR, MCU or E8 may be damaged, please note the power polarity.

Procedure 2 Connect the connector CN1 to E8.

Procedure 3 Connect the connector CN2 to the user target board.

Provide user target power supply and VPP external power supply based on a manual of the flash development tool kit (FDT).

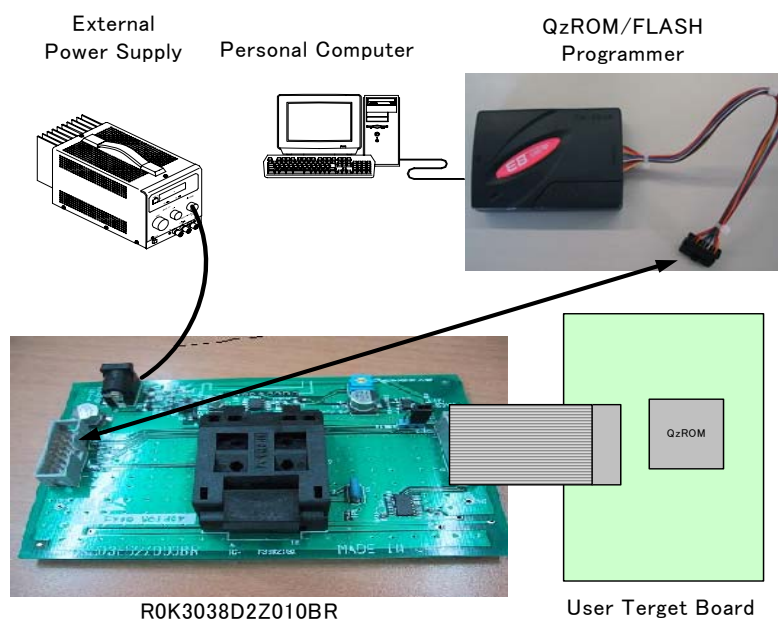
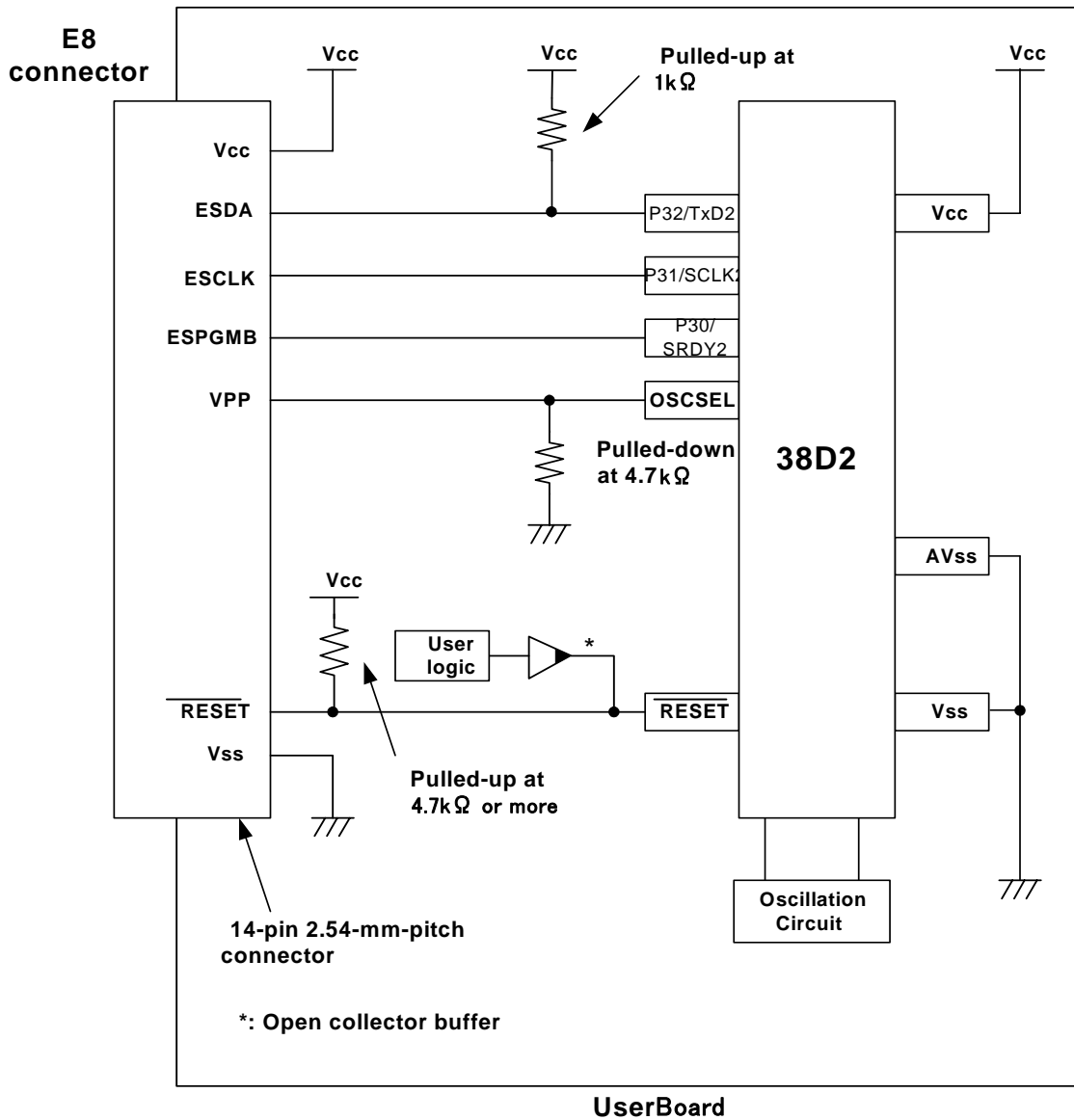

Figure 7.2 Connecting Example 2

7.3. Connection of user target board



8. Latest Information

The latest .38D2 Group IC socket board information can be browsed and downloaded from Renesas web site shown below.

URL :

http://www.renesas.com/fmwk.jsp?cnt=ic_socket_board.jsp&fp=/products/tools/flash_prom_programming/flash_programmers/ic_socket_board/&site=i