

To our customers,

Old Company Name in Catalogs and Other Documents

On April 1st, 2010, NEC Electronics Corporation merged with Renesas Technology Corporation, and Renesas Electronics Corporation took over all the business of both companies. Therefore, although the old company name remains in this document, it is a valid Renesas Electronics document. We appreciate your understanding.

Renesas Electronics website: <http://www.renesas.com>

April 1st, 2010
Renesas Electronics Corporation

Issued by: Renesas Electronics Corporation (<http://www.renesas.com>)

Send any inquiries to <http://www.renesas.com/inquiry>.

Notice

1. All information included in this document is current as of the date this document is issued. Such information, however, is subject to change without any prior notice. Before purchasing or using any Renesas Electronics products listed herein, please confirm the latest product information with a Renesas Electronics sales office. Also, please pay regular and careful attention to additional and different information to be disclosed by Renesas Electronics such as that disclosed through our website.
2. Renesas Electronics does not assume any liability for infringement of patents, copyrights, or other intellectual property rights of third parties by or arising from the use of Renesas Electronics products or technical information described in this document. No license, express, implied or otherwise, is granted hereby under any patents, copyrights or other intellectual property rights of Renesas Electronics or others.
3. You should not alter, modify, copy, or otherwise misappropriate any Renesas Electronics product, whether in whole or in part.
4. Descriptions of circuits, software and other related information in this document are provided only to illustrate the operation of semiconductor products and application examples. You are fully responsible for the incorporation of these circuits, software, and information in the design of your equipment. Renesas Electronics assumes no responsibility for any losses incurred by you or third parties arising from the use of these circuits, software, or information.
5. When exporting the products or technology described in this document, you should comply with the applicable export control laws and regulations and follow the procedures required by such laws and regulations. You should not use Renesas Electronics products or the technology described in this document for any purpose relating to military applications or use by the military, including but not limited to the development of weapons of mass destruction. Renesas Electronics products and technology may not be used for or incorporated into any products or systems whose manufacture, use, or sale is prohibited under any applicable domestic or foreign laws or regulations.
6. Renesas Electronics has used reasonable care in preparing the information included in this document, but Renesas Electronics does not warrant that such information is error free. Renesas Electronics assumes no liability whatsoever for any damages incurred by you resulting from errors in or omissions from the information included herein.
7. Renesas Electronics products are classified according to the following three quality grades: "Standard", "High Quality", and "Specific". The recommended applications for each Renesas Electronics product depends on the product's quality grade, as indicated below. You must check the quality grade of each Renesas Electronics product before using it in a particular application. You may not use any Renesas Electronics product for any application categorized as "Specific" without the prior written consent of Renesas Electronics. Further, you may not use any Renesas Electronics product for any application for which it is not intended without the prior written consent of Renesas Electronics. Renesas Electronics shall not be in any way liable for any damages or losses incurred by you or third parties arising from the use of any Renesas Electronics product for an application categorized as "Specific" or for which the product is not intended where you have failed to obtain the prior written consent of Renesas Electronics. The quality grade of each Renesas Electronics product is "Standard" unless otherwise expressly specified in a Renesas Electronics data sheets or data books, etc.

"Standard": Computers; office equipment; communications equipment; test and measurement equipment; audio and visual equipment; home electronic appliances; machine tools; personal electronic equipment; and industrial robots.

"High Quality": Transportation equipment (automobiles, trains, ships, etc.); traffic control systems; anti-disaster systems; anti-crime systems; safety equipment; and medical equipment not specifically designed for life support.

"Specific": Aircraft; aerospace equipment; submersible repeaters; nuclear reactor control systems; medical equipment or systems for life support (e.g. artificial life support devices or systems), surgical implantations, or healthcare intervention (e.g. excision, etc.), and any other applications or purposes that pose a direct threat to human life.

8. You should use the Renesas Electronics products described in this document within the range specified by Renesas Electronics, especially with respect to the maximum rating, operating supply voltage range, movement power voltage range, heat radiation characteristics, installation and other product characteristics. Renesas Electronics shall have no liability for malfunctions or damages arising out of the use of Renesas Electronics products beyond such specified ranges.
9. Although Renesas Electronics endeavors to improve the quality and reliability of its products, semiconductor products have specific characteristics such as the occurrence of failure at a certain rate and malfunctions under certain use conditions. Further, Renesas Electronics products are not subject to radiation resistance design. Please be sure to implement safety measures to guard them against the possibility of physical injury, and injury or damage caused by fire in the event of the failure of a Renesas Electronics product, such as safety design for hardware and software including but not limited to redundancy, fire control and malfunction prevention, appropriate treatment for aging degradation or any other appropriate measures. Because the evaluation of microcomputer software alone is very difficult, please evaluate the safety of the final products or system manufactured by you.
10. Please contact a Renesas Electronics sales office for details as to environmental matters such as the environmental compatibility of each Renesas Electronics product. Please use Renesas Electronics products in compliance with all applicable laws and regulations that regulate the inclusion or use of controlled substances, including without limitation, the EU RoHS Directive. Renesas Electronics assumes no liability for damages or losses occurring as a result of your noncompliance with applicable laws and regulations.
11. This document may not be reproduced or duplicated, in any form, in whole or in part, without prior written consent of Renesas Electronics.
12. Please contact a Renesas Electronics sales office if you have any questions regarding the information contained in this document or Renesas Electronics products, or if you have any other inquiries.

(Note 1) "Renesas Electronics" as used in this document means Renesas Electronics Corporation and also includes its majority-owned subsidiaries.

(Note 2) "Renesas Electronics product(s)" means any product developed or manufactured by or for Renesas Electronics.

SuperH™ Family E10A-USB Emulator

Additional Document for User's Manual

Supplementary Information on Using the SH7214 and
SH7216

Renesas Microcomputer Development Environment System
SuperH™ Family

E10A-USB for SH7216

HS7216KCU01HE

Notes regarding these materials

1. This document is provided for reference purposes only so that Renesas customers may select the appropriate Renesas products for their use. Renesas neither makes warranties or representations with respect to the accuracy or completeness of the information contained in this document nor grants any license to any intellectual property rights or any other rights of Renesas or any third party with respect to the information in this document.
2. Renesas shall have no liability for damages or infringement of any intellectual property or other rights arising out of the use of any information in this document, including, but not limited to, product data, diagrams, charts, programs, algorithms, and application circuit examples.
3. You should not use the products or the technology described in this document for the purpose of military applications such as the development of weapons of mass destruction or for the purpose of any other military use. When exporting the products or technology described herein, you should follow the applicable export control laws and regulations, and procedures required by such laws and regulations.
4. All information included in this document such as product data, diagrams, charts, programs, algorithms, and application circuit examples, is current as of the date this document is issued. Such information, however, is subject to change without any prior notice. Before purchasing or using any Renesas products listed in this document, please confirm the latest product information with a Renesas sales office. Also, please pay regular and careful attention to additional and different information to be disclosed by Renesas such as that disclosed through our website. (<http://www.renesas.com>)
5. Renesas has used reasonable care in compiling the information included in this document, but Renesas assumes no liability whatsoever for any damages incurred as a result of errors or omissions in the information included in this document.
6. When using or otherwise relying on the information in this document, you should evaluate the information in light of the total system before deciding about the applicability of such information to the intended application. Renesas makes no representations, warranties or guaranties regarding the suitability of its products for any particular application and specifically disclaims any liability arising out of the application and use of the information in this document or Renesas products.
7. With the exception of products specified by Renesas as suitable for automobile applications, Renesas products are not designed, manufactured or tested for applications or otherwise in systems the failure or malfunction of which may cause a direct threat to human life or create a risk of human injury or which require especially high quality and reliability such as safety systems, or equipment or systems for transportation and traffic, healthcare, combustion control, aerospace and aeronautics, nuclear power, or undersea communication transmission. If you are considering the use of our products for such purposes, please contact a Renesas sales office beforehand. Renesas shall have no liability for damages arising out of the uses set forth above.
8. Notwithstanding the preceding paragraph, you should not use Renesas products for the purposes listed below:
 - (1) artificial life support devices or systems
 - (2) surgical implantations
 - (3) healthcare intervention (e.g., excision, administration of medication, etc.)
 - (4) any other purposes that pose a direct threat to human lifeRenesas shall have no liability for damages arising out of the uses set forth in the above and purchasers who elect to use Renesas products in any of the foregoing applications shall indemnify and hold harmless Renesas Technology Corp., its affiliated companies and their officers, directors, and employees against any and all damages arising out of such applications.
9. You should use the products described herein within the range specified by Renesas, especially with respect to the maximum rating, operating supply voltage range, movement power voltage range, heat radiation characteristics, installation and other product characteristics. Renesas shall have no liability for malfunctions or damages arising out of the use of Renesas products beyond such specified ranges.
10. Although Renesas endeavors to improve the quality and reliability of its products, IC products have specific characteristics such as the occurrence of failure at a certain rate and malfunctions under certain use conditions. Please be sure to implement safety measures to guard against the possibility of physical injury, and injury or damage caused by fire in the event of the failure of a Renesas product, such as safety design for hardware and software including but not limited to redundancy, fire control and malfunction prevention, appropriate treatment for aging degradation or any other applicable measures. Among others, since the evaluation of microcomputer software alone is very difficult, please evaluate the safety of the final products or system manufactured by you.
11. In case Renesas products listed in this document are detached from the products to which the Renesas products are attached or affixed, the risk of accident such as swallowing by infants and small children is very high. You should implement safety measures so that Renesas products may not be easily detached from your products. Renesas shall have no liability for damages arising out of such detachment.
12. This document may not be reproduced or duplicated, in any form, in whole or in part, without prior written approval from Renesas.
13. Please contact a Renesas sales office if you have any questions regarding the information contained in this document, Renesas semiconductor products, or if you have any other inquiries.

Regulatory Compliance Notices

European Union Regulatory Notices on Electromagnetic Compatibility

CE Certifications:

This product complies with the following European EMC standards.

- EMC Directive 2004/108/EC
EN 55022 Class A

WARNING: This is a Class A product. In a domestic environment this product may cause radio interference in which case the user may be required to take adequate measures.

EN 55024

Information for Traceability:

- Authorized representative
Name: Renesas Technology Corp.
Address: Nippon Bldg., 2-6-2, Ote-machi, Chiyoda-ku, Tokyo 100-0004, Japan
- Manufacturer
Name: Renesas Solutions Corp.
Address: Nippon Bldg., 2-6-2, Ote-machi, Chiyoda-ku, Tokyo 100-0004, Japan
- Person responsible for placing on the market
Name: Renesas Technology Europe Limited European Headquarters
Address: Dukes Meadow, Millboard Road, Bourne End, Buckinghamshire, SL8 5FH, U.K.

United States Regulatory Notices on Electromagnetic Compatibility

FCC Certifications:

This equipment has been tested and found to comply with the limits for a Class A digital device, pursuant to Part 15 of the FCC Rules. These limits are designed to provide reasonable protection against harmful interference when the equipment is operated in a commercial environment. This equipment generates, uses, and can radiate radio frequency energy and, if not installed and used in accordance with the instruction manual, may cause harmful interference to radio communications. Operation of this equipment in a residential area is likely to cause harmful interference in which case the user will be required to correct the interference at his own expense.

This device complies with Part 15 of the FCC Rules. Operation is subject to the following two conditions: (1) this device may not cause harmful interference, and (2) this device must accept any interference received, including interference that may cause undesired operation.

CAUTION: Changes or modifications not expressly approved by the party responsible for compliance could void the user's authority to operate the equipment.

Contents





Section 1 Connecting the Emulator with the User System.....	1
1.1 Components of the Emulator	1
1.2 Connecting the Emulator with the User System	2
1.3 Installing the H-UDI Port Connector on the User System	3
1.4 Pin Assignments of the H-UDI Port Connector	4
1.5 Recommended Circuit between the H-UDI Port Connector and the MCU	8
1.5.1 Recommended Circuit (36-Pin Type).....	8
1.5.2 Recommended Circuit (14-Pin Type).....	10
1.5.3 Recommended Circuit (38-Pin Type).....	12
Section 2 Software Specifications when Using the SH7214 and SH7216 Group	15
2.1 Differences between the MCU and the Emulator	15
2.2 Specific Functions for the Emulator when Using the SH7214 and SH7216 Group.....	21
2.2.1 Event Condition Functions	21
2.2.2 Trace Functions	27
2.2.3 Note on Using the JTAG (H-UDI) Clock (TCK).....	38
2.2.4 Notes on Setting the [Breakpoint] Dialog Box	39
2.2.5 Notes on Setting the [Event Condition] Dialog Box and the BREAKCONDITION_ SET Command	39
2.2.6 Performance Measurement Function	40

Section 1 Connecting the Emulator with the User System

1.1 Components of the Emulator

The E10A-USB emulator supports the SH7214 and SH7216 group. Table 1.1 lists the components of the emulator.

Table 1.1 Components of the Emulator

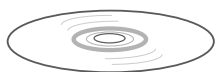
Classification	Component	Appearance	Quantity	Remarks
Hardware	Emulator box		1	HS0005KCU01H: Depth: 65.0 mm, Width: 97.0 mm, Height: 20.0 mm, Mass: 72.9 g or HS0005KCU02H: Depth: 65.0 mm, Width: 97.0 mm, Height: 20.0 mm, Mass: 73.7 g
	User system interface cable		1	14-pin type: Length: 20 cm, Mass: 33.1 g
	User system interface cable		1	36-pin type: Length: 20 cm, Mass: 49.2 g (only for HS0005KCU02H)
	USB cable		1	Length: 150 cm, Mass: 50.6 g
Software	E10A-USB emulator setup program, SuperH™ Family E10A-USB Emulator User's Manual, Supplementary Information on Using the SH7214 and SH7216*, and Test program manual for HS0005KCU01H and HS0005KCU02H		1	HS0005KCU01SR, HS0005KCU01HJ, HS0005KCU01HE, HS7216KCU01HJ, HS7216KCU01HE, HS0005TM01HJ, and HS0005TM01HE (provided on a CD-R)

Note: Additional document for the MCUs supported by the emulator is included. Check the target MCU and refer to its additional document.

1.2 Connecting the Emulator with the User System

To connect the E10A-USB emulator (hereinafter referred to as the emulator), the H-UDI port connector must be installed on the user system to connect the user system interface cable. When designing the user system, refer to the recommended circuit between the H-UDI port connector and the MCU. In addition, read the E10A-USB emulator user's manual and hardware manual for the related device.

Table 1.2 shows the type number of the emulator, the corresponding connector type, and the use of AUD function.

Table 1.2 Type Number, AUD Function, and Connector Type

Type Number	Connector	AUD Function
HS0005KCU02H	36-pin connector	Available
HS0005KCU01H, HS0005KCU02H	14-pin connector	Not available
HS0005KCU02H	38-pin connector	Available

The H-UDI port connector has the 36-pin, 14-pin, and 38-pin types as described below. Use them according to the purpose of the usage.

1. 36-pin type (with AUD function)

The AUD trace function is supported. A large amount of trace information can be acquired in realtime. The window trace function is also supported for acquiring memory access in the specified range (memory access address or memory access data) by tracing.

2. 14-pin type (without AUD function)

The AUD trace function cannot be used because only the H-UDI function is supported. Since the 14-pin type connector is smaller than the 36-pin type (1/2.5), the size of the area where the connector is installed on the user system can be reduced.

3. 38-pin type (with AUD function)

The AUD trace function is supported. As well as the 36-pin type, a large amount of trace information can be acquired in realtime. Since the 38-pin type connector is smaller than the 36-pin type (1/2.5), the size of the area where the connector is installed on the user system can be reduced. To use the 38-pin type connector, however, an optional cable (HS0005ECK01H) is required.

1.3 Installing the H-UDI Port Connector on the User System

Table 1.3 shows the recommended H-UDI port connectors for the emulator.

Table 1.3 Recommended H-UDI Port Connectors

Connector	Type Number	Manufacturer	Specifications
36-pin connector	DX10M-36S	Hirose Electric Co., Ltd.	Screw type
	DX10M-36SE, DX10G1M-36SE		Lock-pin type
14-pin connector	2514-6002	3M Limited.	14-pin straight type
38-pin connector	2-5767004-2	Tyco Electronics AMP K.K.	38-pin Mictor type

Note: When designing the 36-pin connector layout on the user board, do not connect any components under the H-UDI connector. When designing the 14-pin connector layout on the user board, do not place any components within 3 mm of the H-UDI port connector. When designing the 38-pin connector layout on the user board, reduce cross-talk noise etc. by keeping other signal lines out of the region where the H-UDI port connector is situated. As shown in figure 1.1, an upper limit (5 mm) applies to the heights of components mounted around the user system connector.

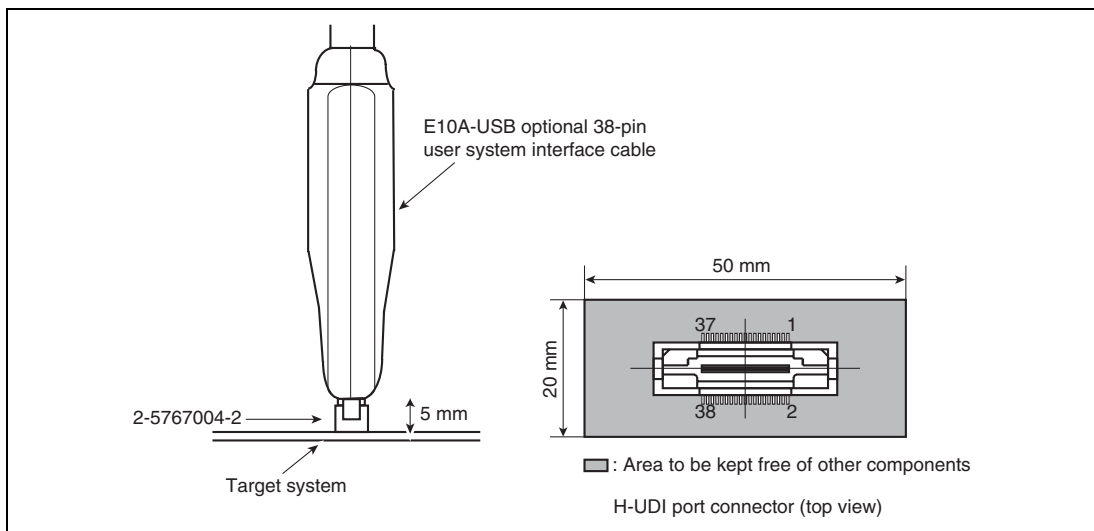

Figure 1.1 Restriction on Component Mounting

1.4 Pin Assignments of the H-UDI Port Connector

Figures 1.2 through 1.4 show the pin assignments of the 36-pin, 14-pin, and 38-pin H-UDI port connectors, respectively.

Note: Note that the pin number assignments of the H-UDI port connector shown on the following pages differ from those of the connector manufacturer.

Pin No.	Signal	Input/ ₁ Output	SH7214, SH7216 Pin No.		Note	Pin No.	Signal	Input/ ₁ Output	SH7214, SH7216 Pin No.		Note
			LQFP -176	LFPGA -176					LQFP -176	LFPGA -176	
1	AUDCK	Output	82	M12		19	TMS	Input	128	D14	
2	GND	—				20	GND	—			
3	AUDATA0	Output	77	N11		21	TRST# ^{*2}	Input	129	C12	
4	GND	—				22	(GND) ^{*4}	—			
5	AUDATA1	Output	78	R11		23	TDI	Input	125	D15	
6	GND	—				24	GND	—			
7	AUDATA2	Output	79	P11		25	TDO	Output	126	C15	
8	GND	—				26	GND	—			
9	AUDATA3	Output	80	M11		27	ASEBRKAK# /ASEBRK# ^{*2}	Input/ output	134	C13	
10	GND	—				28	GND	—			
11	AUDSYNC# ₂	Output	81	R12		29	UVCC	Output			
12	GND	—				30	GND	—			
13	N.C.	—				31	RES# ^{*2}	Output	133	A15	User reset
14	GND	—				32	GND	—			
15	N.C.	—				33	GND ^{*3}	Output			
16	GND	—				34	GND	—			
17	TCK	Input	127	D13		35	N.C.	—			
18	GND	—				36	GND	—			

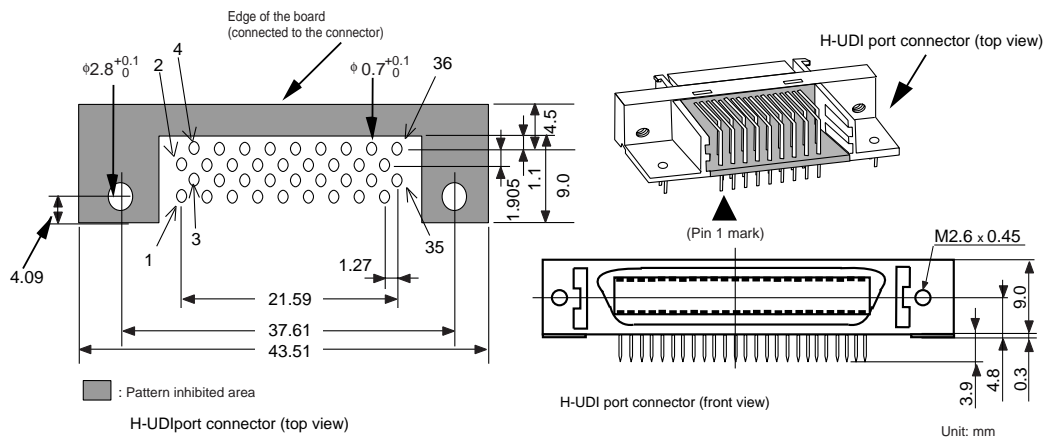

Notes:

1. Input to or output from the user system.
2. The symbol ($_$) means that the signal is active-low.
3. The emulator monitors the GND signal of the user system and detects whether or not the user system is connected.
4. When the user system interface cable is connected to this pin and the ASEMD0# pin is set to 0, do not connect to GND but to the ASEMD0# pin directly.

Figure 1.2 Pin Assignments of the H-UDI Port Connector (36 Pins)

Pin No.	Signal	Input/ Output*1	SH7216, SH7214 Pin No.		Note
			LQFP -176	LFPGA -176	
1	TCK	Input	127	D13	
2	TRST# *2	Input	129	C12	
3	TDO	Output	126	C15	
4	ASEBRKAK# /ASEBRK#*2	Input/ Output	134	C13	
5	TMS	Input	128	D14	
6	TDI	Input	125	D15	
7	RES# *2	Output	133	A15	User reset
8	N.C.	—			
9	(GND) *4	—			
11	UVCC	Output			
10,12,13	GND	—			
14	GND *3	Output			

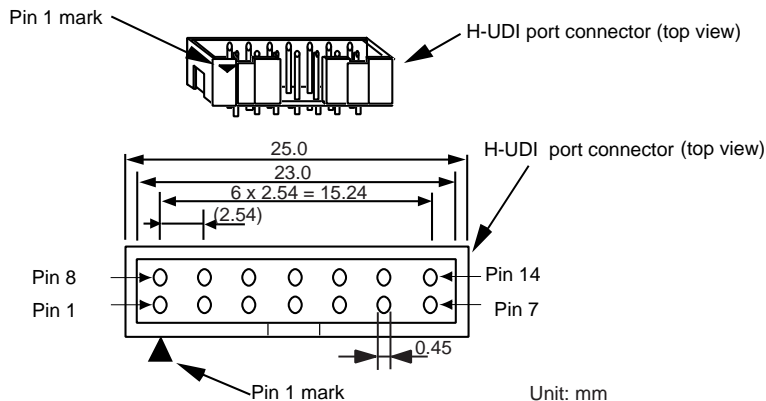

Notes:

1. Input to or output from the user system.
2. The symbol ($_$) means that the signal is active-low.
3. The emulator monitors the GND signal of the user system and detects whether or not the user system is connected.
4. When the user system interface cable is connected to this pin and the ASEMD0# pin is set to 0, do not connect to GND but to the ASEMD0# pin directly.

Figure 1.3 Pin Assignments of the H-UDI Port Connector (14 Pins)

Pin No.	Signal	Input/Output ¹	SH7216, SH7214 Pin No.		Note	Pin No.	Signal	Input/ ¹ Output	SH7216, SH7214 Pin No.		Note
			LQFP -176	LFBGA -176					LQFP -176	LFBGA -176	
1	N.C.	—				20	N.C.	—			
2	N.C.	—				21	TRST# ²	Input	129	C12	
3	ASEMD#(GND) ⁴	—				22	N.C.	—			
4	N.C.	—				23	N.C.	—			
5	UCON#(GND) ³	—				24	AUDATA3	Output	80	M11	
6	AUDCK	Output	82	M12		25	N.C.	—			
7	N.C.	—				26	AUDATA2	Output	79	P11	
8	ASEBRKAK#/ ASEBRK# ²	Input/ Output	134	C13		27	N.C.	—			
9	RES# ²	Output	133	A15	User reset	28	AUDATA1	Output	78	R11	
10	N.C.	—				29	N.C.	—			
11	TDO	Output	126	C15		30	AUDATA0	Output	77	N11	
12	UVCC_AUD	Output				31	N.C.	—			
13	N.C.	—				32	AUDSYNC# ²	Output	81	R12	
14	UVCC	Output				33	N.C.	—			
15	TCK	Input	127	D13		34	N.C.	—			
16	N.C.	—				35	N.C.	—			
17	TMS	Input	128	D14		36	N.C.	—			
18	N.C.	—				37	N.C.	—			
19	TDI	Input	125	D15		38	N.C.	—			

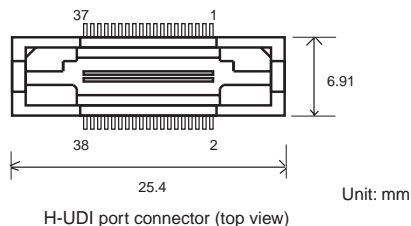

Notes:

1. Input to or output from the user system.
2. The symbol () means that the signal is active-low.
3. The emulator monitors the GND signal of the user system and detects whether or not the user system is connected.
4. When the user system interface cable is connected to this pin and the ASEMD0 pin is set to 0, do not connect to GND but to the ASEMD0 pin directly.
5. The GND bus lead at the center of the H-UDI port connector must be grounded.

Figure 1.4 Pin Assignments of the H-UDI Port Connector (38 Pins)

1.5 Recommended Circuit between the H-UDI Port Connector and the MCU

1.5.1 Recommended Circuit (36-Pin Type)

Figures 1.5 shows recommended circuits for connection between the H-UDI and AUD port connectors (36 pins) and the MCU when the emulator is in use.

- Notes:
1. Do not connect anything to the N.C. pins of the H-UDI port connector.
 2. The ASEMD0# pin must be 0 when the emulator is connected and 1 when the emulator is not connected, respectively.
 - (1) When the emulator is used: ASEMD0# = 0
 - (2) When the emulator is not used: ASEMD0# = 1Figures 1.5 shows examples of circuits that allow the _ASEMD pin to be GND (0) whenever the emulator is connected by using the user system interface cable. When the ASEMD0# pin is changed by switches, etc., ground pin 22. Do not connect this pin to the ASEMD0# pin.
 3. When a network resistance is used for pull-up, it may be affected by a noise. Separate TCK from other resistances.
 4. The pattern between the H-UDI port connector and the MCU must be as short as possible. Do not connect the signal lines to other components on the board.
 5. The AUD signals (AUDCK, AUDATA3 to AUDATA0, and AUDSYNC#) operate in high speed. Isometric connection is needed if possible. Do not separate connection nor connect other signal lines adjacently.
 6. Since the H-UDI and the AUD of the MCU operate with the VCCQ, supply only the VCCQ to the UVCC pin. Make the emulator's switch settings so that the user power will be supplied (SW2 = 1 and SW3 = 1).
 7. The resistance values shown in figures 1.5 is for reference.
 8. For the AUDCK pin, guard the pattern between the H-UDI port connector and the MCU at GND level.
 9. For the pin processing in cases where the emulator is not used, refer to the hardware manual of the related MCU.

When the circuit is connected as shown in figure 1.5, the switches of the emulator are set as SW2 = 1 and SW3 = 1. For details, refer to section 3.8, Setting the DIP Switches, in the SuperH™ Family E10A-USB Emulator User's Manual.

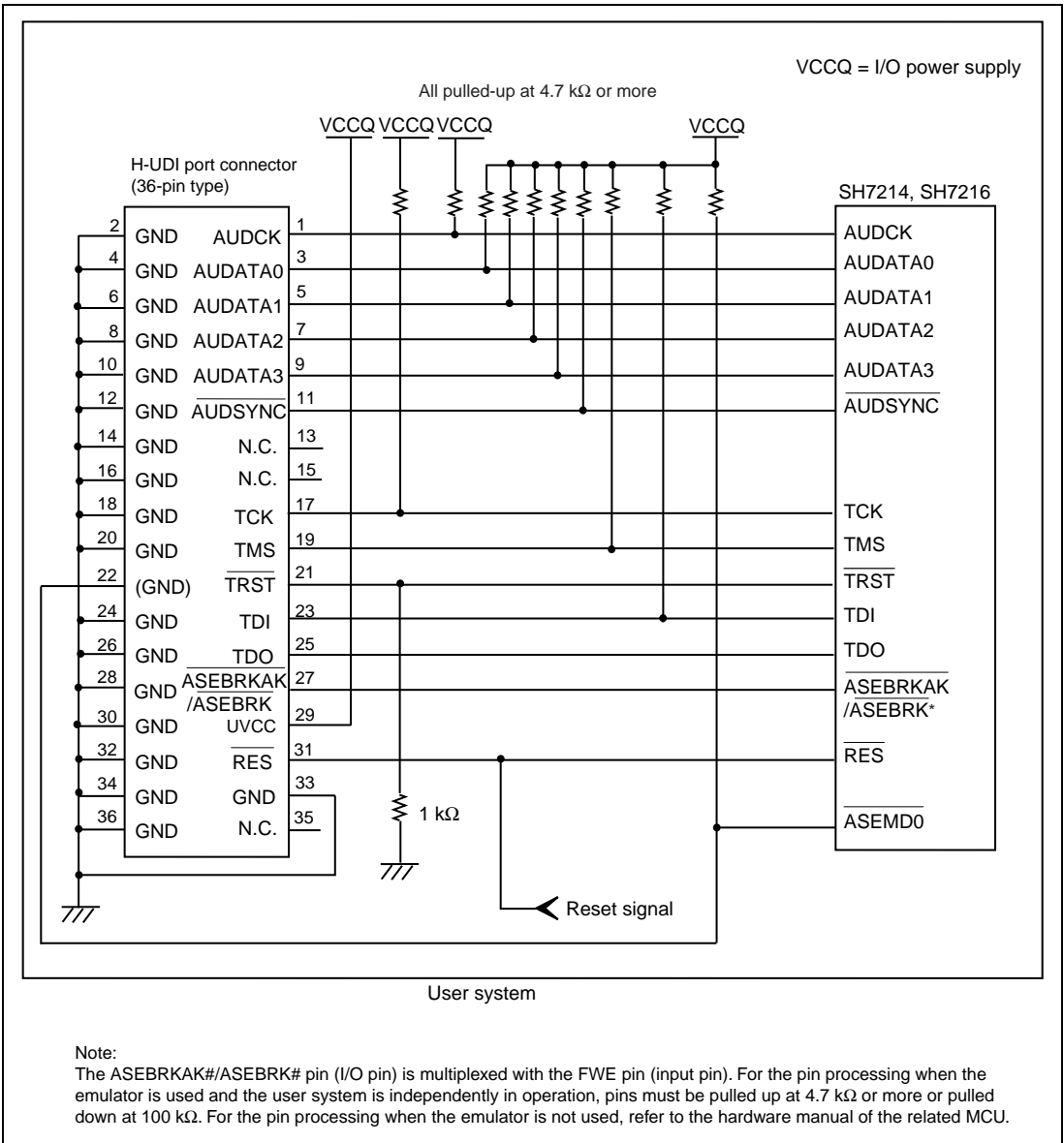

Figure 1.5 Recommended Circuit for Connection between the H-UDI Port Connector and MCU when the Emulator is in Use (36-Pin Type)

1.5.2 Recommended Circuit (14-Pin Type)

Figures 1.6 shows recommended circuits for connection between the H-UDI port connectors (14 pins) and the MCU when the emulator is in use.

- Notes:
1. Do not connect anything to the N.C. pins of the H-UDI port connector.
 2. The ASEMD0# pin must be 0 when the emulator is connected and 1 when the emulator is not connected, respectively.
 - (1) When the emulator is used: ASEMD0# = 0
 - (2) When the emulator is not used: ASEMD0# = 1Figures 1.6 shows examples of circuits that allow the ASEMD0# pin to be GND (0) whenever the emulator is connected by using the user system interface cable. When the ASEMD0# pin is changed by switches, etc., ground pin 9. Do not connect this pin to the ASEMD0# pin.
 3. When a network resistance is used for pull-up, it may be affected by a noise. Separate TCK from other resistances.
 4. The pattern between the H-UDI port connector and the MCU must be as short as possible. Do not connect the signal lines to other components on the board.
 5. Since the H-UDI and the AUD of the MCU operate with the VCCQ, supply only the VCCQ to the UVCC and UVCC_AUD pins. Make the emulator's switch settings so that the user power will be supplied (SW2 = 1 and SW3 = 1).
 6. The resistance values shown in figures 1.6 is for reference.
 7. For the pin processing in cases where the emulator is not used, refer to the hardware manual of the related MCU.

When the circuit is connected as shown in figure 1.6, the switches of the emulator are set as SW2 = 1 and SW3 = 1. For details, refer to section 3.8, Setting the DIP Switches, in the SuperH™ Family E10A-USB Emulator User's Manual.

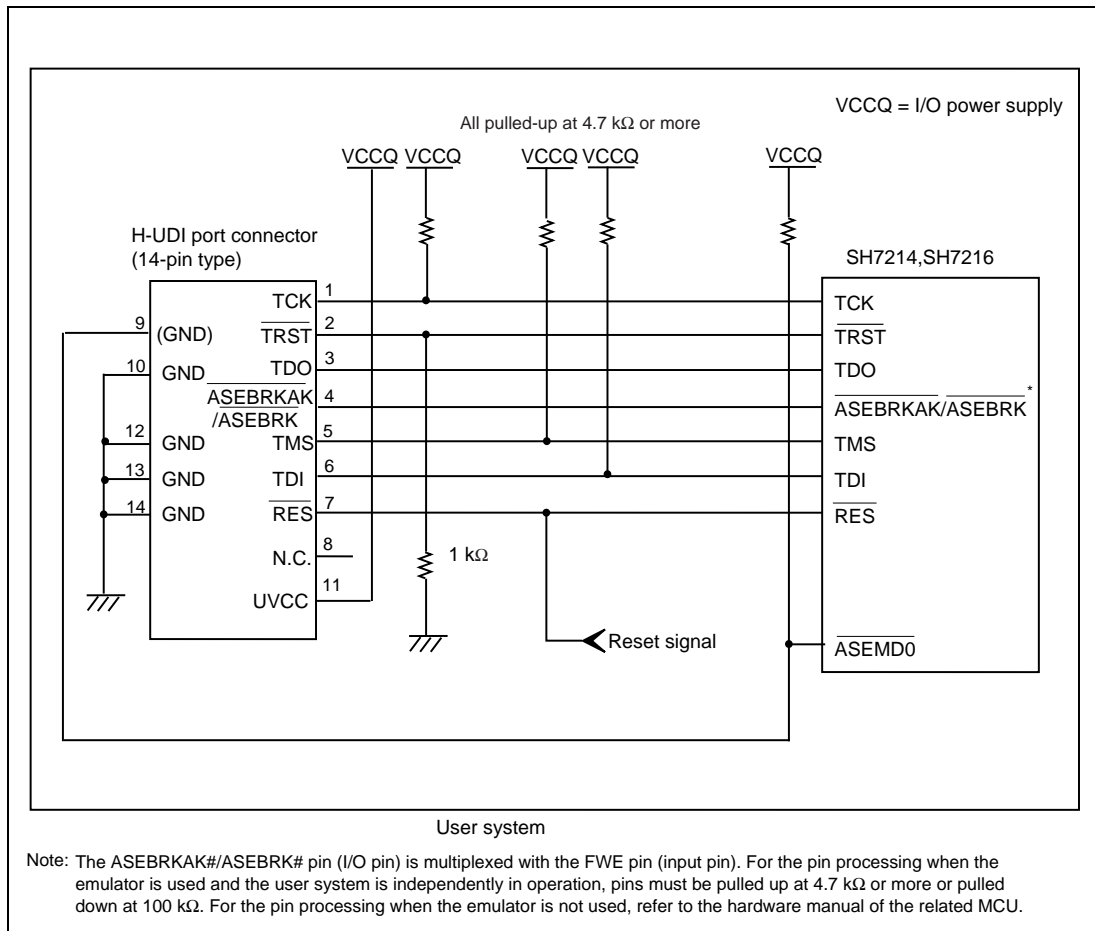

Figure 1.6 Recommended Circuit for Connection between the H-UDI Port Connector and MCU when the Emulator is in Use (14-Pin Type)

1.5.3 Recommended Circuit (38-Pin Type)

Figures 1.7 shows recommended circuits for connection between the H-UDI port connectors (38 pins) and the MCU when the emulator is in use.

- Notes:
1. Do not connect anything to the N.C. pins of the H-UDI port connector.
 2. The ASEMD0# pin must be 0 when the emulator is connected and 1 when the emulator is not connected, respectively.
 - (1) When the emulator is used: ASEMD0# = 0
 - (2) When the emulator is not used: ASEMD0# = 1Figures 1.7 shows examples of circuits that allow the ASEMD0# pin to be GND (0) whenever the emulator is connected by using the user system interface cable. When the ASEMD0# pin is changed by switches, etc., ground pin 3. Do not connect this pin to the ASEMD0# pin.
 3. When a network resistance is used for pull-up, it may be affected by a noise. Separate TCK from other resistances.
 4. The pattern between the H-UDI port connector and the MCU must be as short as possible. Do not connect the signal lines to other components on the board.
 5. Since the H-UDI and the AUD of the MCU operate with the VCCQ, supply only the VCCQ to the UVCC and UVCC_AUD pins. Make the emulator's switch settings so that the user power will be supplied (SW2 = 1 and SW3 = 1).
 6. The resistance values shown in figures 1.7 is for reference.
 7. For the AUDCK pin, guard the pattern between the H-UDI port connector and the MCU at GND level.
 8. The GND bus lead at the center of the H-UDI port connector must be grounded.
 9. For the pin processing in cases where the emulator is not used, refer to the hardware manual of the related MCU.

When the circuit is connected as shown in figure 1.7, the switches of the emulator are set as SW2 = 1 and SW3 = 1. For details, refer to section 3.8, Setting the DIP Switches, in the SuperH™ Family E10A-USB Emulator User's Manual.

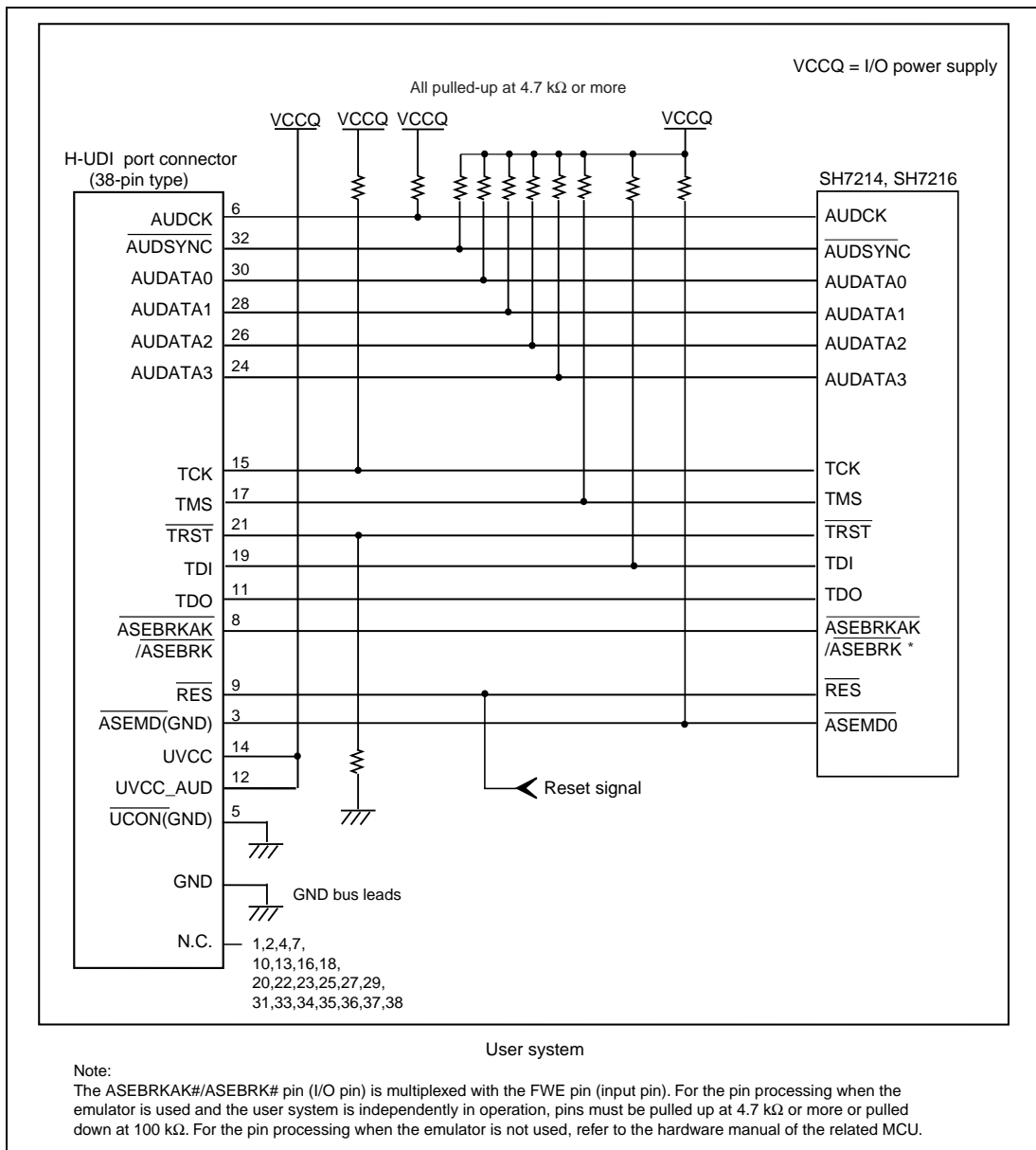

Figure 1.7 Recommended Circuit for Connection between the H-UDI Port Connector and MCU when the Emulator is in Use (38-Pin Type)

Section 2 Software Specifications when Using the SH7214 and SH7216 Group

2.1 Differences between the MCU and the Emulator

1. When the emulator system is initiated, it initializes the general registers and part of the control registers as shown in table 2.1. The initial values of the MCU are undefined. When the emulator is initiated from the workspace, a value to be entered is saved in a session.

Table 2.1 Register Initial Values at Emulator Link Up

Register	Emulator at Link Up
R0 to R14	H'00000000
R15 (SP)	Value of the SP in the power-on reset vector table
PC	Value of the PC in the power-on reset vector table
SR	H'000000F0
GBR	H'00000000
VBR	H'00000000
TBR	H'00000000
MACH	H'00000000
MACL	H'00000000
PR	H'00000000
FPSCR*	H'00040001
FPUL*	H'00000000
FPR0-15*	H'00000000

Note: This value is not displayed for MCUs which do not have floating point units (FPUs).

2. The emulator uses the H-UDI; do not access the H-UDI.
3. Low-Power States
 - When the emulator is used, the sleep state can be cleared with either the clearing function or with the [STOP] button, and a break will occur.
 - The memory must not be accessed or modified in software standby state.
 - Do not stop inputting the clock to the H-UDI module by using the module standby function.
4. Reset Signals

The MCU reset signals are only valid during emulation started with clicking the GO or STEP-type button. If these signals are enabled on the user system in command input wait state, they are not sent to the MCU.

Note: Do not break the user program when the `_RES`, `_BREQ`, or `_WAIT` signal is being low. A TIMEOUT error will occur. If the `_BREQ` or `_WAIT` signal is fixed to low during break, a TIMEOUT error will occur at memory access.

5. Direct Memory Access Controller (DMAC)

The DMAC operates even when the emulator is used. When a data transfer request is generated, the DMAC executes DMA transfer.

6. Memory Access during User Program Execution

During execution of the user program, memory is accessed by the following two methods, as shown in table 2.2.

Table 2.2 Memory Access during User Program Execution

Method	Description
H-UDI read/write	The stopping time of the user program is short because memory is accessed by the dedicated bus master.
Short break	The stopping time of the user program is long because the user program temporarily breaks.

The method for accessing memory during execution of the user program is specified by using the [Configuration] dialog box.

Table 2.3 Stopping Time by Memory Access (Reference)

Method	Condition	Stopping Time
H-UDI read/write	Reading of one longword for the internal RAM	Reading: Maximum three bus clocks (B ϕ)
	Writing of one longword for the internal RAM	Writing: Maximum two bus clocks (B ϕ)
Short break	CPU clock: 160 MHz JTAG clock: 20 MHz Reading or writing of one longword for the external area	About 50 ms

7. Memory Access to the External Flash Memory Area

The emulator can download the load module to the external flash memory area (for details, refer to section 6.22, Download Function to the Flash Memory Area, in the SuperH™ Family E10A-USB Emulator User's Manual). Other memory write operations are enabled for the RAM area. Therefore, an operation such as memory write or BREAKPOINT should be set only for the RAM area.

8. ROM Cache

For ROM cache in the MCU, the emulator operates as shown in table 2.4.

Table 2.4 Operation for ROM Cache

Function	Operation
Write and erase	Writes or erases all contents of ROM cache.
Download	
Memory read	Accesses the disabled cache area to read the content of internal flash memory.

9. Multiplexing the Emulator Pins

A part of the emulator pins is multiplexed as shown in table 2.5.

Table 2.5 Multiplexed Functions

MCU	Function 1	Function 2
SH7214 and SH7216 group	FWE	_ASEBRKAK/_ASEBRK
	PD16/D16/IRQ0/POE0/UBCTRG	AUDATA0
	PD17/D17/IRQ1/POE4/ADTRG	AUDATA1
	PD18/D18/IRQ2/MDIO	AUDATA2
	PD19/D19/IRQ3/LNKSTA	AUDATA3
	PD21/D21/IRQ5/TEND1/EXOUT	AUDCK
	PD20/D20/IRQ4/AUDSYNC/MDC	_AUDSYNC

Note: Function 1 can be used when the AUD pins of the device are not connected to the emulator.

The AUD pins are multiplexed with other pins. When the AUD function is used by the SH7214 and SH7216 group E10A-USB emulator, AUD pins are used regardless of the settings of the pin function controller (PFC).

10. Using WDT

The WDT does not operate during break.

11. Loading Sessions

Information in [JTAG clock] of the [Configuration] dialog box cannot be recovered by loading sessions. Thus the TCK value will be as follows:

- When HS0005KCU01H or HS0005KCU02H is used: TCK = 5 MHz

12. [IO] Window

- Display and modification
- For each watchdog timer register, there are two registers to be separately used for write and read operations.

Table 2.6 Watchdog Timer Register

Register Name	Usage	Register
WTCSR(W)	Write	Watchdog timer control/status register
WTCNT(W)	Write	Watchdog timer counter
WTCSR(R)	Read	Watchdog timer control/status register
WTCNT(R)	Read	Watchdog timer counter
WRCSR(W)	Write	Watchdog reset control/status register
WRCSR(R)	Read	Watchdog reset control/status register

- Customization of the I/O-register definition file

The internal I/O registers can be accessed from the [IO] window. After the I/O-register definition file is created, the MCU's specifications may be changed. If each I/O register in the I/O-register definition file differs from addresses described in the hardware manual, change the I/O-register definition file according to the description in the hardware manual. The I/O-register definition file can be customized depending on its format. However, the emulator does not support the bit-field function.

- Verify

In the [IO] window, the verify function of the input value is disabled.

13. Illegal Instructions

Do not execute illegal instructions with STEP-type commands.

14. Reset Input

During execution of the user program, the emulator may not operate correctly if a contention occurs between the following operations for the emulator and the reset input to the target device:

- Setting an Event Condition
- Setting an internal trace
- Displaying the content acquired by an internal trace
- Reading or writing of a memory

Note that those operations should not contend with the reset input to the target device.

15. Contention between the Change of the FRQCR Register and the Debugging Functions

The following notes are required for the user program for changing the division ratio of the divider to change the frequency:

- Avoid contention between the change of the FRQCR register in the user program and the memory access from the [Memory] window, etc.
- When the automatic updating function is used in the [Monitor] window or [Watch] window, generate and set a break of Event Condition for an instruction immediately before changing the FRQCR register. Contention will be avoided by generating a break and executing the user program again.

For the change of the division ratio of the divider and the FRQCR register, refer to the hardware manual for the MCU.

16. MCU Operating Mode

Note that the emulator does not support the boot mode and user boot mode.

17. Access to the Data Flash Memory (FLD)

During execution of a program in the CS area, do not use emulator operations for access to the FLD. Otherwise, the FLD instruction fetch error bit in the flash access status register (FASTAT) will be set to indicate an FLD instruction error.

During execution of the user program, do not use emulator operations for access to a block of the data mat which is protected against reading.

18. Emulation of Programming and Erasure of the Internal Flash Memory

The setting of the FWE pins is ignored while the emulator is connected. The flash write enable bit (FWE) of the flash pin monitor register (FPMON) becomes undefined. Note this point if the bit is referred to during execution of the user program.

When the MCU is operating in mode 2 (MCU expansion mode) or in mode 3 (MCU single chip mode), writing and erasing of the internal flash memory by programs is possible. Thus, if emulation is to include writing or erasure of the internal flash memory, the MCU operating mode must be mode 2 (MCU expansion mode) or mode 3 (MCU single chip mode). Do not select mode 6 (user program mode) or mode 7 (USB boot mode and user program mode) while the emulator is connected.

Break processing is not possible during calls of the programs for writing and erasing the internal flash memory. Note that the following processing cannot be performed.

- STOP button
- Automatic updating and tool chip watching for the watch function
- Memory operations during emulation
- Profiling function
- Monitor function
- AUD trace function (non-realtime trace mode)

Do not set the breakpoint in a block of the internal flash memory that will be a target for writing or erasure.

For emulating programming or erasure of the internal flash memory, select the [Flash memory to PC] or [PC to flash memory, Flash memory to PC] item from the [Flash memory synchronization] drop-down list box in the [Configuration] dialog box -> [General] page; do not select the [Disable] or [PC to flash memory] items. Also, Select the [Eeprom memory to PC] from the [Eeprom memory synchronization] drop-down list box. Do not select the [Disable] item.

19. Selection of the Target Device

The item to be selected in the [Select Emulator mode] dialog box depends on the week-code of the SH7216 emulator. When the chip in use has a week-code earlier than [0927], select the item below in the [Select Emulator mode] dialog box.

R5F72167AD (week-code is earlier than [0927]): R5F72167AD_Option

2.2 Specific Functions for the Emulator when Using the SH7214 and SH7216 Group

2.2.1 Event Condition Functions

The emulator is used to set event conditions for the following three functions:

- Break of the user program
- Internal trace
- Start or end of performance measurement

Table 2.7 lists the types of Event Condition.

Table 2.7 Types of Event Condition

Event Condition Type	Description
Address bus condition (Address)	Sets a condition when the address bus (data access) value or the program counter value (before or after execution of instructions) is matched.
Data bus condition (Data)	Sets a condition when the data bus value is matched. Byte, word, or longword can be specified as the access data size.
Bus state condition (Bus State)	There are two bus state condition settings: Bus state condition: Sets a condition when the data bus value is matched. Read/Write condition: Sets a condition when the read/write condition is matched.
Count	Sets a condition when the specified other conditions are satisfied for the specified counts.
Reset point	A reset point is set when the count and the sequential condition are specified.
Action	Selects the operation when a condition (such as a break, a trace halt condition, or a trace acquisition condition) is matched.

Use the [Combination action(Sequential or PtoP)] dialog box to specify the sequential condition, the point-to-point operation of the internal trace, and the start or end of performance measurement.

Table 2.8 lists the combinations of conditions that can be set under Ch1 to Ch11.

Table 2.8 Dialog Boxes for Setting Event Conditions

Dialog Box		Function				Action
		Address Bus Condition (Address)	Data Bus Condition (Data)	Bus State Condition (Bus Status)	Count Condition (Count)	
[Event Condition 1]	Ch1	O	O	O	O	O (B, T1, and P)
[Event Condition 2]	Ch2	O	O	O	X	O (B, T1, and P)
[Event Condition 3]	Ch3	O	X	X	X	O (B and T2)
[Event Condition 4]	Ch4	O	X	X	X	O (B and T3)
[Event Condition 5]	Ch5	O	X	X	X	O (B and T3)
[Event Condition 6]	Ch6	O	X	X	X	O (B and T2)
[Event Condition 7]	Ch7	O	X	X	X	O (B and T2)
[Event Condition 8]	Ch8	O	X	X	X	O (B and T2)
[Event Condition 9]	Ch9	O	X	X	X	O (B and T2)
[Event Condition 10]	Ch10	O	X	X	X	O (B and T2)
[Event Condition 11]	Ch11	O (reset point)	X	X	X	X

- Notes: 1. O: Can be set in the dialog box.
X: Cannot be set in the dialog box.
2. For the Action item,
B: Setting a break is enabled.
T1: Setting the trace halt and acquisition conditions are enabled for the internal trace.
T2: Setting the trace halt is enabled for the internal trace.
T3: Setting the trace halt and point-to-point is enabled for the internal trace.
P: Setting a performance-measurement start or end condition is enabled.

The [Event Condition 11] dialog box is used to specify the count of [Event Condition 1] and becomes a reset point when the sequential condition is specified.

Sequential Setting: Using the [Combination action (Sequential or PtoP)] dialog box specifies the sequential condition and the start or end of performance measurement.

Table 2.9 Conditions to Be Set

Classification	Item	Description
[Ch1, 2, 3] list box	Sets the sequential condition and the start or end of performance measurement using Event Conditions 1 to 3 and 11.	
	Don't care	Sets no sequential condition or the start or end of performance measurement.
	Break: Ch3-2-1	Breaks when a condition is satisfied in the order of Event Condition 3, 2, 1.
	Break: Ch3-2-1, Reset point	Breaks when a condition is satisfied in the order of Event Condition 3, 2, 1. Enables the reset point of Event Condition 11.
	Break: Ch2-1	Breaks when a condition is satisfied in the order of Event Condition 2, 1.
	Break: Ch2-1, Reset point	Breaks when a condition is satisfied in the order of Event Condition 2, 1. Enables the reset point.
	I-Trace stop: Ch3-2-1	Halts acquisition of an internal trace when a condition is satisfied in the order of Event Condition 3, 2, 1.
	I-Trace stop: Ch3-2-1, Reset point	Halts acquisition of an internal trace when a condition is satisfied in the order of Event Condition 3, 2, 1. Enables the reset point.
	I-Trace stop: Ch2-1	Halts acquisition of an internal trace when a condition is satisfied in the order of Event Condition 2, 1.
	I-Trace stop: Ch2-1, Reset point	Halts acquisition of an internal trace when a condition is satisfied in the order of Event Condition 2, 1. Enables the reset point.
	Ch2 to Ch1 PA	Sets the performance measurement period during the time from the satisfaction of the condition set in Event Condition 2 (start condition) to the satisfaction of the condition set in Event Condition 1 (end condition).

Table 2.9 Conditions to Be Set (cont)

Classification	Item	Description
[Ch1, 2, 3] list box (cont)	Ch1 to Ch2 PA	Sets the performance measurement period during the time from the satisfaction of the condition set in Event Condition 1 (start condition) to the satisfaction of the condition set in Event Condition 2 (end condition).
[Ch4, 5] list box	Sets the point-to-point of the internal trace (the start or end condition of trace acquisition) using Event Conditions 4 and 5.	
	Don't care	Sets no start or end condition of trace acquisition.
	I-Trace: Ch5 to Ch4 PtoP	Sets the acquisition period during the time from the satisfaction of the condition set in Event Condition 5 (start condition) to the satisfaction of the condition set in Event Condition 4 (end condition).
	I-Trace: Ch5 to Ch4 PtoP, power-on reset	Sets the acquisition period during the time from the satisfaction of the condition set in Event Condition 5 (start condition) to the satisfaction of the condition set in Event Condition 4 (end condition) or the power-on reset.

- Notes:
1. After the sequential condition and the count specification condition of Event Condition 1 have been set, break and trace acquisition will be halted if the sequential condition is satisfied for the specified count.
 2. If a reset point is satisfied, the satisfaction of the condition set in Event Condition will be disabled. For example, if the condition is satisfied in the order of Event Condition 3, 2, reset point, 1, the break or trace acquisition will not be halted. If the condition is satisfied in the order of Event Condition 3, 2, reset point, 3, 2, 1, the break and trace acquisition will be halted.
 3. If the start condition is satisfied after the end condition has been satisfied by measuring performance, performance measurement will be restarted. For the measurement result after a break, the measurement results during performance measurement are added.
 4. If the start condition is satisfied after the end condition has been satisfied by the point-to-point of the internal trace, trace acquisition will be restarted.

Usage Example of Sequential Break Extension Setting: A tutorial program provided for the product is used as an example. For the tutorial program, refer to section 6, Tutorial, in the SuperH™ Family E10A-USB Emulator User's Manual.

The conditions of Event Condition are set as follows:

1. Ch3

Breaks address H'00001068 when the condition [Only program fetched address after] is satisfied.

2. Ch2

Breaks address H'0000107a when the condition [Only program fetched address after] is satisfied.

3. Ch1

Breaks address H'00001086 when the condition [Only program fetched address after] is satisfied.

Note: Do not set other channels.

4. Sets the content of the [Ch1,2,3] list box to [Break: Ch 3-2-1] in the [Combination action (Sequential or PtoP)] dialog box.

5. Enables the condition of Event Condition 1 from the popup menu by clicking the right mouse button on the [Event Condition] sheet.

Then, set the program counter and stack pointer (PC = H'00000800, R15 = H'00010000) in the [Registers] window and click the [Go] button. If this does not execute normally, issue a reset and execute the above procedures.

The program is executed up to the condition of Ch1 and halted. Here, the condition is satisfied in the order of Ch3 -> 2 -> 1.

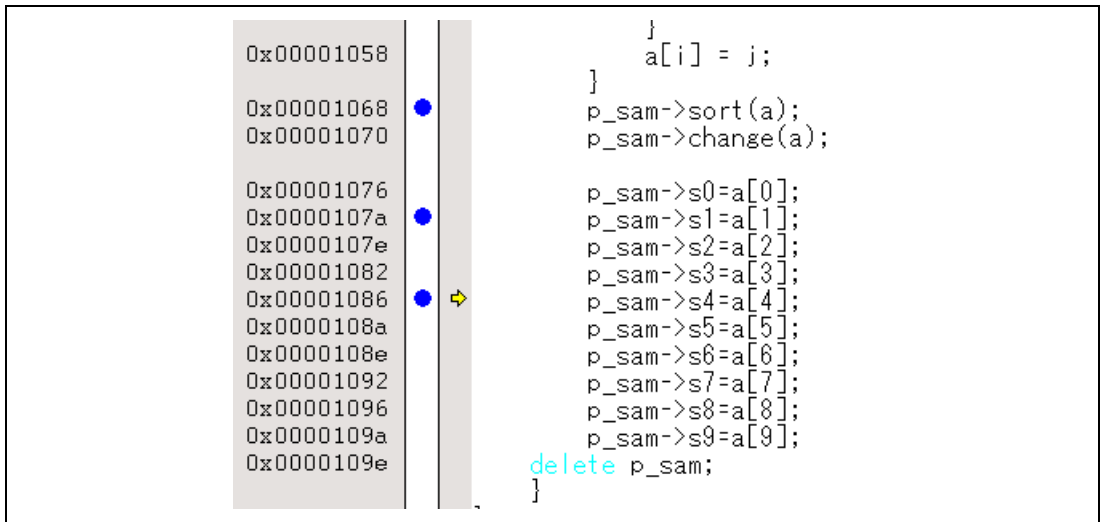

Figure 2.1 [Source] Window at Execution Halted (Sequential Break)

If the sequential condition, performance measurement start/end, or point-to-point for the internal trace is set, conditions of Event Condition to be used will be disabled. Such conditions must be enabled from the popup menu by clicking the right mouse button on the [Event Condition] sheet.

- Notes:
1. If the Event condition is set for the slot in the delayed branch instruction by the program counter (after execution of the instruction), the condition is satisfied before executing the instruction in the branch destination (when a break has been set, it occurs before executing the instruction in the branch destination).
 2. Do not set the Event condition for the SLEEP instruction by the program counter (after execution of the instruction).
 3. When the Event condition is set for the 32-bit instruction by the program counter, set that condition in the upper 16 bits of the instruction.
 4. If the power-on reset and the Event condition are matched simultaneously, no condition will be satisfied.
 5. Do not set the Event condition for the DIVU or DIVS instruction by the program counter (after execution of the instruction).
 6. If a condition of which intervals are satisfied closely is set, no sequential condition will be satisfied.
 - Set the Event conditions, which are satisfied closely, by the program counter with intervals of two or more instructions.
 - After the Event condition has been matched by accessing data, set the Event condition by the program counter with intervals of 17 or more instructions.

7. If the settings of the Event condition or the sequential conditions are changed during execution of the program, execution will be suspended. (The number of clocks to be suspended during execution of the program is a maximum of about 102 bus clocks (B ϕ). If the bus clock (B ϕ) is 20 MHz, the program will be suspended for 5.1 μ s.)
8. If the settings of Event conditions or the sequential conditions are changed during execution of the program, the emulator temporarily disables all Event conditions to change the settings. During this period, no Event condition will be satisfied.
9. If the break condition before executing an instruction is set to the instruction followed by DIVU and DIVS, the factor for halting a break will be incorrect under the following condition:
If a break occurs during execution of the above DIVU and DIVS instructions, the break condition before executing an instruction, which has been set to the next instruction, may be displayed as the factor for halting a break.
10. If the break conditions before and after executing instructions are set to the same address, the factor for halting a break will be incorrectly displayed. The factor for halting a break due to the break condition after executing an instruction will be displayed even if a break is halted by the break condition before executing an instruction.
11. Do not set the break condition after executing instructions and BREAKPOINT (software break) to the same address.
12. When the emulator is being connected, the user break controller (UBC) function is not available.

2.2.2 Trace Functions

The emulator supports the trace functions listed in table 2.10.

Table 2.10 Trace Functions

Function	Internal Trace	AUD Trace
Branch trace	Supported	Supported
Memory access trace	Supported	Supported
Software trace	Not supported	Supported

Table 2.11 shows the type numbers that the AUD function can be used.

Table 2.11 Type Number and AUD Function

Type Number	AUD Function
HS0005KCU01H	Not supported
HS0005KCU02H	Supported

The internal and AUD traces are set in the [Acquisition] dialog box of the [Trace] window.

Internal Trace Function: When [I-Trace] is selected for [Trace type] on the [Trace Mode] page of the [Acquisition] dialog box, the internal trace can be used.

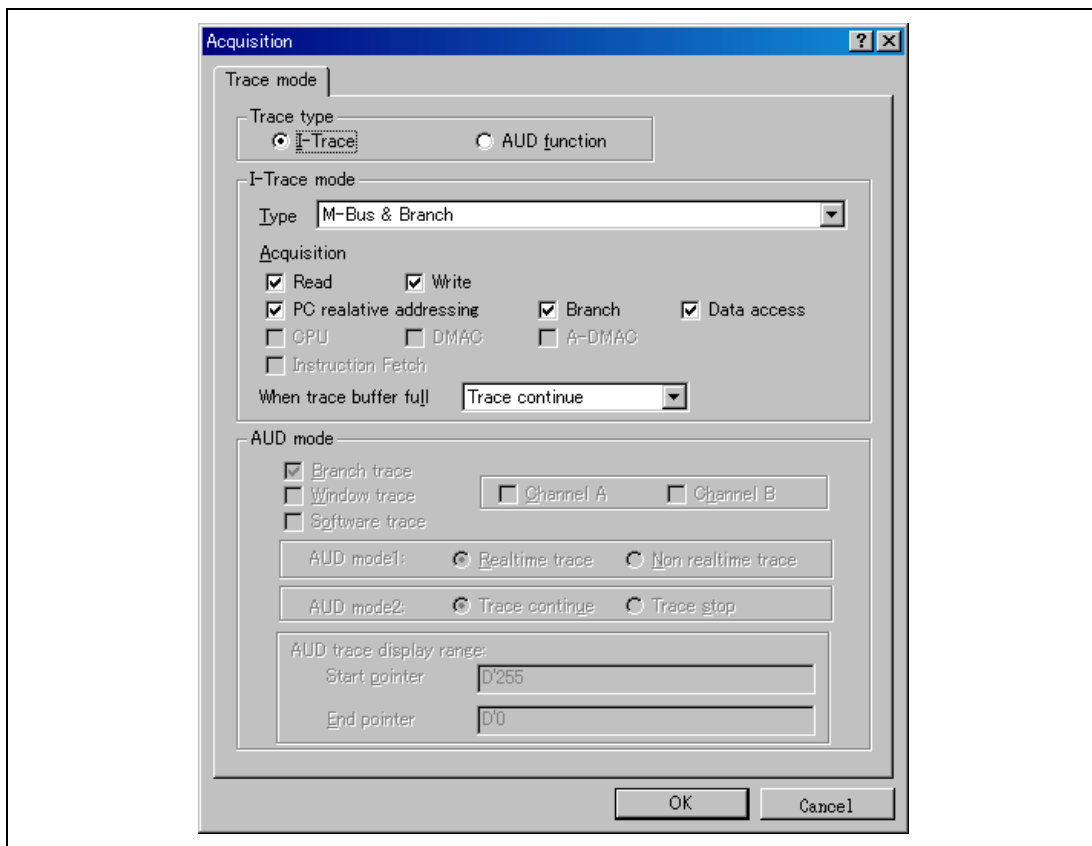

Figure 2.2 [Acquisition] Dialog Box – Internal Trace Function

The following three items can be selected as the internal trace from [Type] of [I-Trace mode].

Table 2.12 Information on Acquiring the Internal Trace

Item	Information Acquired
[M-Bus & Branch]	Data and branch information on the M-bus. <ul style="list-style-type: none"> • Data access (read/write) • PC-relative access • Branch information
[I-Bus]	Data on the I-bus. <ul style="list-style-type: none"> • Data access (read/write) • Selection of the bus master on the I-bus (CPU/DMA/A-DMA) • Instruction fetching
[F-Bus]	Instruction-fetch information on the F-bus. <ul style="list-style-type: none"> • Instruction fetching
[I-Bus, M-Bus & Branch]	The contents of [M-Bus & Branch] and [I-Bus].
[F-Bus, M-Bus & Branch]	The contents of [M-Bus & Branch] and [F-Bus].
[I-Bus, F-Bus]	The contents of [I-Bus] and [F-Bus].

After selecting [Type] of [I-Trace mode], select the content to be acquired from [Acquisition]. Typical examples are described below (note that items disabled for [Acquisition] are not acquired).

- Example of acquiring branch information only:
Select [M-Bus & Branch] from [Type] and enable [Branch] on [Acquisition].
- Example of acquiring the read or write access (M-bus) only by a user program:
Select [M-Bus & Branch] from [Type] and enable [Read], [Write], and [Data access] on [Acquisition].
- Example of acquiring the read access only by DMA (I-bus):
Select [I-Bus] from [Type] and enable [Read], [DMA], and [Data access] on [Acquisition].

Using Event Condition restricts the condition; the following three items are set as the internal trace conditions.

Table 2.13 Trace Conditions of the Internal Trace

Item	Acquisition Information
Trace halt	Acquires the internal trace until the Event Condition is satisfied. (The trace content is displayed in the [Trace] window after a trace has been halted. No break occurs in the user program.)
Trace acquisition	Acquires only the data access where the Event Condition is satisfied.
Point-to-point	Traces the period from the satisfaction of Event Condition 5 to the satisfaction of Event Condition 4.

To restrict trace acquisition to access for only a specific address or specific function of a program, an Event Condition can be used. Typical examples are described below.

- Example of halting a trace with a write access (M-bus) to H'FFF80000 by the user program as a condition (trace halt):

Set the condition to be acquired on [I-Trace mode].

Set the following in the [Event Condition 1] or [Event Condition 2] dialog box:

Address condition: Set [Address] and H'FFF80000.

Bus state condition: Set [M-Bus] and [Write].

Action condition: Disable [Acquire Break] and set [Acquire Trace] for [Stop].
- Example of acquiring the write access (M-bus) only to H'FFF80000 by the user program (trace acquisition condition):

Select [M-Bus & Branch] from [Type] and enable [Write] and [Data access] on [Acquisition].

Set the following in the [Event Condition 1] or [Event Condition 2] dialog box:

Address condition: Set [Address] and H'FFF80000.

Bus state condition: Set [M-Bus] and [Write].

Action condition: Disable [Acquire Break] and set [Acquire Trace] for [Condition].

For the trace acquisition condition, the condition to be acquired by Event Condition should be acquired by [I-Trace mode].

- Example of acquiring a trace for the period while the program passes H'1000 through H'2000 (point-to-point):

Set the condition to be acquired on [I-Trace mode].

Set the address condition as H'1000 in the [Event Condition 5] dialog box.

Set the address condition as H'2000 in the [Event Condition 4] dialog box.

Set [I-Trace] as [Ch5 to Ch4 PtoP] in the [Combination action (Sequential or PtoP)] dialog box.

When point-to-point and trace acquisition condition are set simultaneously, they are ANDed.

Notes on Internal Trace:

- **Timestamp**
The timestamp is the clock counts of B ϕ (48-bit counter). Table 2.14 shows the timing for acquiring the timestamp.

Table 2.14 Timing for the Timestamp Acquisition

Item	Acquisition Information	Counter Value Stored in the Trace Memory
M-bus data access		Counter value when data access (read or write) has been completed
Branch		Counter value when the next bus cycle has been completed after a branch
I-bus	Fetch	Counter value when a fetch has been completed
	Data access	Counter value when data access has been completed

- **Point-to-point**
The trace-start condition is satisfied when the specified instruction has been fetched. Accordingly, if the trace-start condition has been set for the overrun-fetched instruction (an instruction that is not executed although it has been fetched at a branch or transition to an interrupt), tracing is started during overrun-fetching of the instruction. However, when overrun-fetching is achieved (a branch is completed), tracing is automatically suspended. If the start and end conditions are satisfied closely, trace information will not be acquired correctly.
The execution cycle of the instruction fetched before the start condition is satisfied may be traced.
When the I-bus is acquired, do not specify point-to-point.
- Memory access may not be acquired by the internal trace if it occurs at several instructions immediately before satisfaction of the point-to-point end condition.
- **Halting a trace**
Do not set the trace end condition for the sleep instruction and the branch instruction that the delay slot becomes the sleep instruction.

- Trace acquisition condition

Do not set the trace end condition for the sleep instruction and the branch instruction according to which the delay slot becomes the sleep instruction.

When [I-Bus, M-Bus & Branch] is selected and the trace acquisition condition is set for the M-bus and I-bus with Event Condition, set the M-bus condition and the I-bus condition for [Event Condition 1] and [Event Condition 2], respectively.

If the settings of [I-Trace mode] are changed during execution of the program, execution will be suspended. (The number of clocks to be suspended during execution of the program is 66 bus clocks ($B\phi$). If the bus clock ($B\phi$) is 20 MHz, the program will be suspended for 3.3 μ s.)

- Displaying a trace

If a trace is displayed during execution of the program, execution will be suspended to acquire the trace information. (The number of clocks to be suspended during execution of the program is 24576 bus clocks ($B\phi$). If the bus clock ($B\phi$) is 20 MHz, the program will be suspended for 1228.8 μ s.)

- Branch trace

If breaks occur immediately after executing non-delayed branch and TRAPA instructions and generating a branch due to exception or interrupt, a trace for one branch will not be acquired immediately before such breaks.

However, this does not affect on generation of breaks caused by a BREAKPOINT and a break before executing instructions of Event Condition.

- Writing memory immediately before generating a break

If an instruction is executed to write memory immediately before generating a break, trace acquisition may not be performed.

AUD Trace Functions: This function is operational when the AUD pin of the device is connected to the emulator. Table 2.15 shows the AUD trace acquisition mode that can be set in each trace function.

Table 2.15 AUD Trace Acquisition Mode

Type	Mode	Description
Continuous trace occurs	Realtime trace	When the trace information is being generated intensely that the output from the AUD pin incapable of keeping up, the CPU temporarily suspends the output of trace information. Therefore, although the user program is run in real time, the acquisition of some trace information might not be possible.
	Non realtime trace	When trace information is being generated so intensely that the output from the AUD pin is incapable of keeping up, CPU operations are temporarily suspended and the output of trace information takes priority. In such cases, the realtime characteristics of the user program are lost.
Trace buffer full	Trace continue	This function overwrites the latest trace information to store the oldest trace information.
	Trace stop	After the trace buffer becomes full, the trace information is no longer acquired. The user program is continuously executed.

To set the AUD trace acquisition mode, click the [Trace] window with the right mouse button and select [Setting] from the pop-up menu to display the [Acquisition] dialog box. The AUD trace acquisition mode can be set in the [AUD mode1] or [AUD mode2] group box in the [Trace mode] page of the [Acquisition] dialog box.

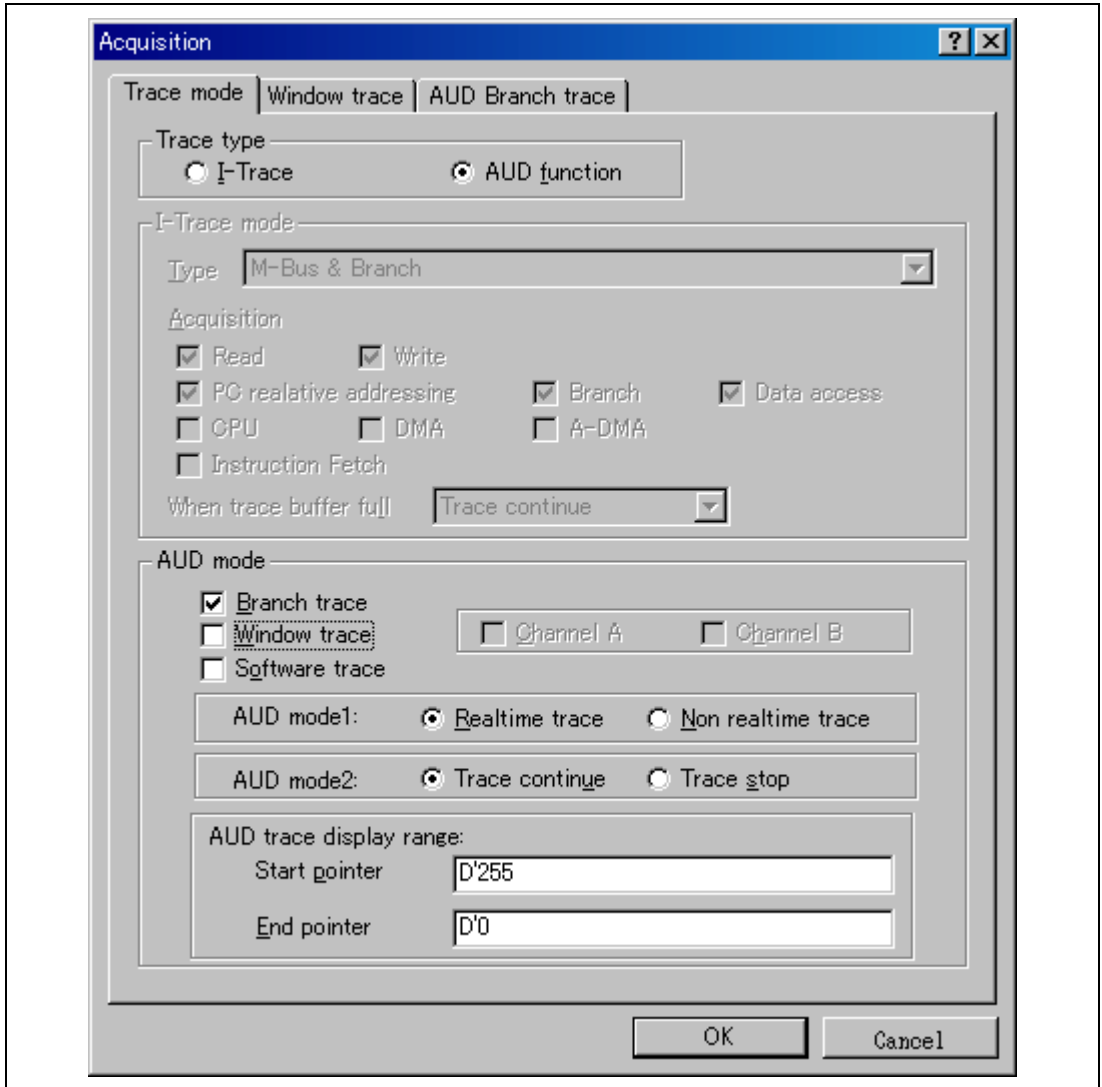

Figure 2.3 [Trace mode] Page

When the AUD trace function is used, select the [AUD function] radio button in the [Trace type] group box of the [Trace mode] page.

(a) Branch Trace Function

The branch source and destination addresses and their source lines are displayed.

Branch trace can be acquired by selecting the [Branch trace] check box in the [AUD function] group box of the [Trace mode] page.

The branch type can be selected in the [AUD Branch trace] page.

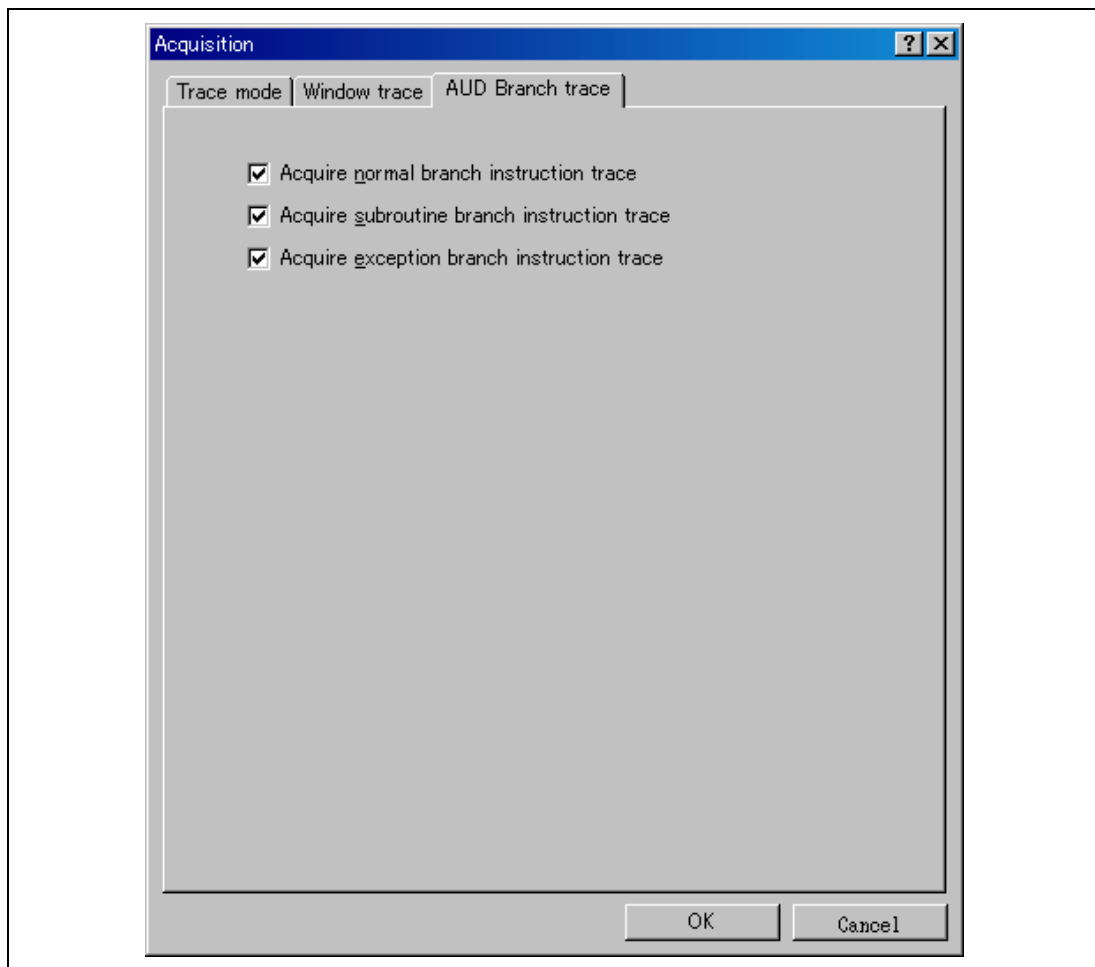

Figure 2.4 [AUD Branch trace] Page

(b) Window Trace Function

Memory access in the specified range can be acquired by trace.

Two memory ranges can be specified for channels A and B. The read, write, or read/write cycle can be selected as the bus cycle for trace acquisition.

[Setting Method]

- (i) Select the [Channel A] and [Channel B] check boxes in the [AUD function] group box of the [Trace mode] page. Each channel will become valid.
- (ii) Open the [Window trace] page and specify the bus cycle, memory range, and bus type that are to be set for each channel.

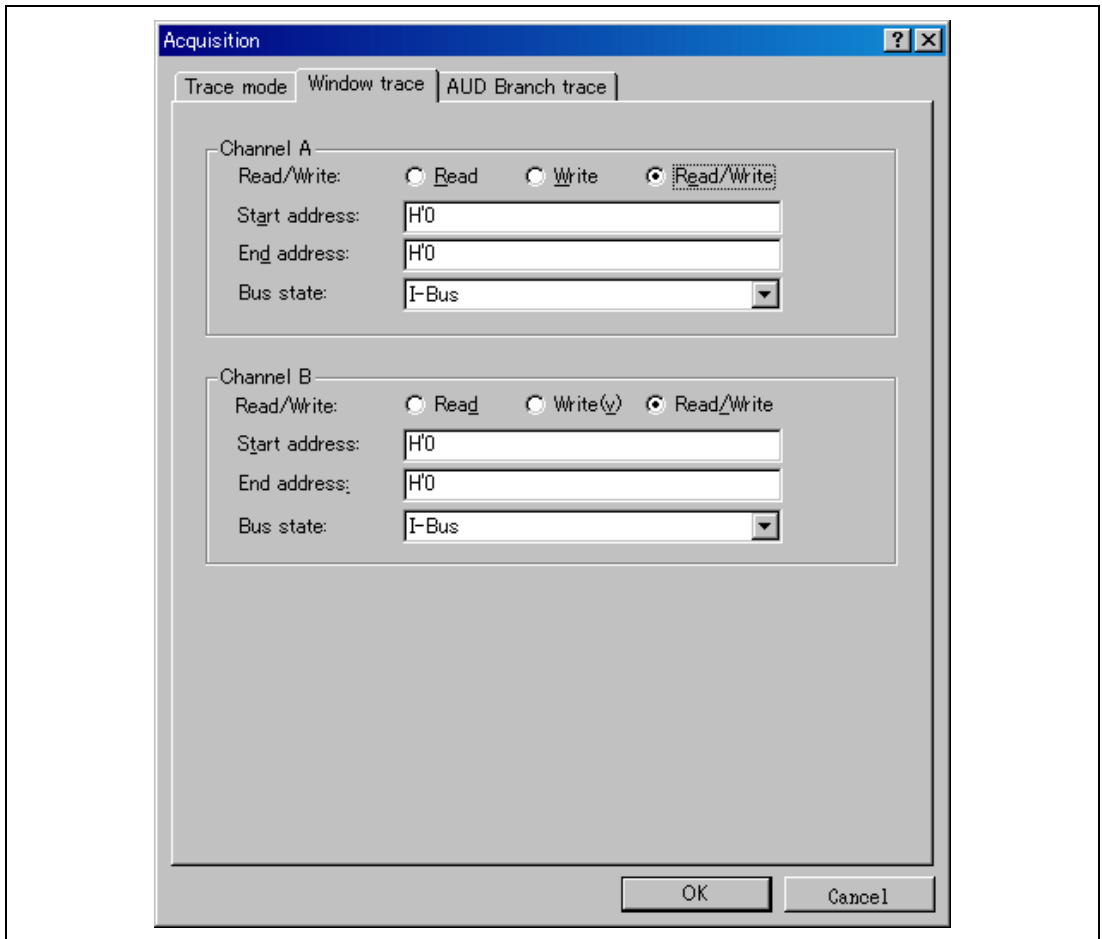

Figure 2.5 [Window trace] Page

Note: When [M-Bus] or [I-Bus] is selected, the following bus cycles will be traced.

- M-Bus: A bus cycle generated by the CPU is acquired.
- I-Bus: A bus cycle generated by the CPU or DMA is acquired.

(c) Software Trace Function

Note: This function can be supported with SHC/C++ compiler (manufactured by Renesas Technology Corp.; including OEM and bundle products) V7.0 or later.

When a specific instruction is executed, the PC value at execution and the contents of one general register are acquired by trace. Describe the Trace(x) function (x is a variable name) to be compiled and linked beforehand. For details, refer to the SHC manual.

When the load module is downloaded on the target system and is executed while a software trace function is valid, the PC value that has executed the Trace(x) function, the general register value for x, and the source lines are displayed.

To activate the software trace function, select the [Software trace] check box in the [AUD function] group box of the [Trace mode] page.

Notes on AUD Trace:

1. When the trace display is performed during user program execution, the mnemonics, operands, or source is not displayed.
2. The AUD trace function outputs the differences between newly output branch source addresses and previously output branch source addresses. The window trace function outputs the differences between newly output addresses and previously output addresses. If the previous branch source address is the same as the upper 16 bits, the lower 16 bits are output. If it matches the upper 24 bits, the lower 8 bits are output. If it matches the upper 28 bits, the lower 4 bits are output.
The emulator regenerates the 32-bit address from these differences and displays it in the [Trace] window. If the emulator cannot display the 32-bit address, it displays the difference from the previously displayed 32-bit address.
3. If the 32-bit address cannot be displayed, the source line is not displayed.
4. If a completion-type exception occurs during exception branch acquisition, the next address to the address in which an exception occurs is acquired.
5. The AUD trace is disabled while the profiling function is used.
6. Set the AUD clock (AUDCK) frequency to 40 MHz or lower. If the frequency is higher than 40 MHz, the emulator will not operate normally.
7. If breaks occur immediately after executing non-delayed branch and TRAPA instructions and generating a branch due to exception or interrupt, a trace for one branch will not be acquired immediately before such breaks. However, this does not affect on generation of breaks caused by a BREAKPOINT and a break before executing instructions of Event Condition.
8. For the result by software trace, a value in the [Data] item is not correct (that value is correct for window trace).

2.2.3 Note on Using the JTAG (H-UDI) Clock (TCK)

1. Set the JTAG clock (TCK) frequency to lower than the frequency of the peripheral module clock (CKP) and to under 25 MHz.
2. The initial value for the JTAG clock (TCK) is 5 MHz.
3. A value to be set for the JTAG clock (TCK) is initialized after executing [Reset CPU] or [Reset Go].

2.2.4 Notes on Setting the [Breakpoint] Dialog Box

1. When an odd address is set, the next lowest even address is used.
2. A BREAKPOINT is accomplished by replacing instructions of the specified address. It cannot be set to the following addresses:
 - An area other than CS and the internal RAM
 - An instruction in which Break Condition 2 is satisfied
 - A slot instruction of a delayed branch instruction
3. During step operation, specifying BREAKPOINTS and Event Condition breaks are disabled.
4. When execution resumes from the address where a BREAKPOINT is specified and a break occurs before Event Condition execution, single-step operation is performed at the address before execution resumes. Therefore, realtime operation cannot be performed.
5. When a BREAKPOINT is set to the slot instruction of a delayed branch instruction, the PC value becomes an illegal value. Accordingly, do not set a BREAKPOINT to the slot instruction of a delayed branch instruction.
6. If an address of a BREAKPOINT cannot be correctly set in the ROM or flash memory area, a mark ● will be displayed in the [BP] area of the address on the [Source] or [Disassembly] window by refreshing the [Memory] window, etc. after Go execution. However, no break will occur at this address. When the program halts with the event condition, the mark ● disappears.
7. If you wish to use a BREAKPOINT (software break), specify the SH2A_SBSTK command to enable use of a user stack before setting a PC break. While enabled, extra four bytes of a user stack are used when a break occurs. The value of the stack pointer (R15) must be correctly set in advance because a user stack is to be used. By default, use of a user stack is disabled. For details on the command, refer to the help file.

- Example

To enable use of a user stack:

```
>SH2A_SBSTK enable
```

2.2.5 Notes on Setting the [Event Condition] Dialog Box and the BREAKCONDITION_SET Command

1. When [Go to cursor], [Step In], [Step Over], or [Step Out] is selected, the settings of Event Condition 3 are disabled.
2. When an Event Condition is satisfied, emulation may stop after two or more instructions have been executed.

2.2.6 Performance Measurement Function

The emulator supports the performance measurement function.

1. Setting the performance measurement conditions

To set the performance measurement conditions, use the [Performance Analysis] dialog box and the PERFORMANCE_SET command. When any line in the [Performance Analysis] window is clicked with the right mouse button, a popup menu is displayed and the [Performance Analysis] dialog box can be displayed by selecting [Setting].

Note: For the command line syntax, refer to the online help.

(a) Specifying the measurement start/end conditions

The measurement start/end conditions are specified by using Event Condition 1,2. The [Ch1,2,3] list box of the [Combination action (Sequential or PtoP)] dialog box can be used.

Table 2.16 Measurement Period

Classification	Item	Description
Selection in the [Ch1, 2, 3] list box	Ch2 to Ch1 PA	The period from the satisfaction of the condition set in Event Condition 2 (start condition) to the satisfaction of the condition set in Event Condition 1 (end condition) is set as the performance measurement period.
	Ch1 to Ch2 PA	The period from the satisfaction of the condition set in Event Condition 1 (start condition) to the satisfaction of the condition set in Event Condition 2 (end condition) is set as the performance measurement period.
	Other than above	The period from the start of execution of the user program to the occurrence of a break is measured.

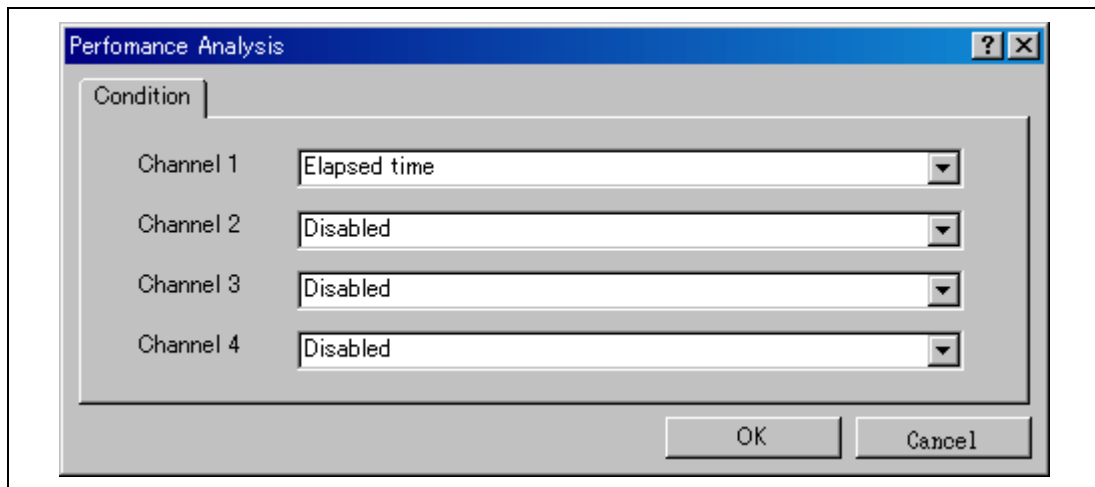

Figure 2.6 [Performance Analysis] Dialog Box

For measurement tolerance,

- The measured value includes tolerance.
- Tolerance will be generated before or after a break.

Note: When [Ch2 to Ch1 PA] or [Ch1 to Ch2 PA] is selected, to execute the user program, specify conditions set in Event Condition 2 and Event Condition 1 and one or more items for performance measurement.

(b) Measurement item

Items are measured with [Channel 1 to 4] in the [Performance Analysis] dialog box. Maximum four conditions can be specified at the same time.

Table 2.17 Measurement Item

Selected Name	Option
Disabled	None
Elapsed time	AC (the number of execution cycles ($I\phi$))
Branch instruction counts	BT
Number of execution instructions	I
Number of execution 32bit-instructions	I32
Exception/interrupt counts	EA
Interrupt counts	INT
Data cache-miss counts	DC
Instruction cache-miss counts	IC
All area access counts	ARN
All area instruction access counts	ARIN
All area data access counts	ARND
Cacheable area access counts	CDN (data access)
Cacheable area instruction access counts	CIN
Non cacheable area data access counts	NCN
URAM area access counts	UN
URAM area instruction access counts	UIN
URAM area data access counts	UDN
Internal I/O area data access counts	IODN
Internal ROM area access counts	RN
Internal ROM area instruction access counts	RIN
Internal ROM area data access counts	RDN
All area access cycle	ARC
All area instruction access cycle	ARIC
All area data access cycle	ARDC
All area access stall	ARS
All area instruction access stall	ARIS
All area data access stall	ARDS

Note: Selected names are displayed for CONDITION in the [Performance Analysis] window.
Options are parameters for <mode> of the PERFORMANCE_SET command.

- Notes:
1. In the non-realtime trace mode of the AUD trace, normal counting cannot be performed because the generation state of the stall or the execution cycle is changed.
 2. For SH7214 and SH7216 group, do not set measurement items for the cache-miss counts, cacheable area, or non-cacheable area.

2. Displaying the measured result

The measured result is displayed in the [Performance Analysis] window or the PERFORMANCE_ANALYSIS command with hexadecimal (32 bits).

Note: If a performance counter overflows as a result of measurement, “*****” will be displayed.

3. Initializing the measured result

To initialize the measured result, select [Initialize] from the popup menu in the [Performance Analysis] window or specify INIT with the PERFORMANCE_ANALYSIS command.

SuperH™ Family E10A-USB Emulator
Additional Document for User's Manual
Supplementary Information on Using the SH7214 and SH7216

Publication Date: Rev.1.00, January 13, 2010
Published by: Sales Strategic Planning Div.
Renesas Technology Corp.
Edited by: Customer Support Department
Global Strategic Communication Div.
Renesas Solutions Corp.

Renesas Technology Corp. Sales Strategic Planning Div. Nippon Bldg., 2-6-2, Ohte-machi, Chiyoda-ku, Tokyo 100-0004, Japan



RENESAS SALES OFFICES

<http://www.renesas.com>

Refer to "<http://www.renesas.com/en/network>" for the latest and detailed information.

Renesas Technology America, Inc.
450 Holger Way, San Jose, CA 95134-1368, U.S.A
Tel: <1> (408) 382-7500, Fax: <1> (408) 382-7501

Renesas Technology Europe Limited
Dukes Meadow, Millboard Road, Bourne End, Buckinghamshire, SL8 5FH, U.K.
Tel: <44> (1628) 585-100, Fax: <44> (1628) 585-900

Renesas Technology (Shanghai) Co., Ltd.
Unit 204, 205, AZIACenter, No.1233 Lujiazui Ring Rd, Pudong District, Shanghai, China 200120
Tel: <86> (21) 5877-1818, Fax: <86> (21) 6887-7858/7898

Renesas Technology Hong Kong Ltd.
7th Floor, North Tower, World Finance Centre, Harbour City, Canton Road, Tsimshatsui, Kowloon, Hong Kong
Tel: <852> 2265-6688, Fax: <852> 2377-3473

Renesas Technology Taiwan Co., Ltd.
10th Floor, No.99, Fushing North Road, Taipei, Taiwan
Tel: <886> (2) 2715-2888, Fax: <886> (2) 3518-3399

Renesas Technology Singapore Pte. Ltd.
1 Harbour Front Avenue, #06-10, Keppel Bay Tower, Singapore 098632
Tel: <65> 6213-0200, Fax: <65> 6278-8001

Renesas Technology Korea Co., Ltd.
Kukje Center Bldg. 18th Fl., 191, 2-ka, Hangang-ro, Yongsan-ku, Seoul 140-702, Korea
Tel: <82> (2) 796-3115, Fax: <82> (2) 796-2145

Renesas Technology Malaysia Sdn. Bhd
Unit 906, Block B, Menara Amcorp, Amcorp Trade Centre, No.18, Jln Persiaran Barat, 46050 Petaling Jaya, Selangor Darul Ehsan, Malaysia
Tel: <603> 7955-9390, Fax: <603> 7955-9510

SuperH™ Family E10A-USB Emulator
Additional Document for User's Manual
Supplementary Information on Using the SH7214 and
SH7216



Renesas Electronics Corporation

1753, Shimonumabe, Nakahara-ku, Kawasaki-shi, Kanagawa 211-8668 Japan

REJ10J2109-0100