

## 32176 Group

### Application Using the Serial Interface (UART Mode)

---

#### 1. Overview

This documentation describes a sample program using 32176 Group microcomputer's on-chip serial interface (serial I/O).

#### 2. Introduction

The example application described in this documentation uses the following microcomputer under the respective conditions.

- Microcomputer: 32176 Group (M32176FnVFP, M32176FnTFP)
- Operating frequency: 20 to 40 MHz (The sample program is compiled assuming a frequency of 40 MHz)
- Operating Board: Starter kit for 32176 Group

### 3. Explanation of the Technology Applied

#### 3.1 Outline of the Serial Interface

The 32176 contains a total of four serial interface channels, SIO0, SIO1, SIO2, and SIO3. SIO0 and SIO1 can be selected between CSIO mode (clock-synchronous serial interface) and UART mode (clock-asynchronous serial interface). Channels SIO2 and SIO3 are UART mode only.

- CSIO Mode (clock-synchronous serial interface)

Communication is performed synchronously with a transfer clock, using the same clock for both transmit and receive sides. The transfer data is 8 bits long (fixed).

- UART Mode (clock-asynchronous serial interface)

Communication is performed at any transfer rate in any transfer data format. The transfer data length can be selected from 7, 8, or 9 bits.

Channels SIO0, SIO1, SIO2, and SIO3 each have transmit DMA transfer and a receive DMA transfer request. These serial interfaces, when combined with the internal DMA Controller (DMAC), allow serial communication to be performed at high speed, as well as reduce the data communication load of the CPU.

In the UART mode, the transfer rate is decided by clock divider frequency division value and the values set in the individual baud rate registers (BRG) for each channel. The table below shows sample setting values for each baud rate.

**Table 3.1.1 Sample Baud Rate Register Settings**

Baud Rate (bps)	Item	Clock Divider Count Source = 20 MHz			
		Clock Divider Frequency Division Value (Frequency Division)	BRG Setting Value	Error (%)	Actual Baud Rate (bps)
300		32	129	0.16	300.48
600		32	64	0.16	600.96
1200		8	129	0.16	1201.92
2400		8	64	0.16	2403.85
4800		8	32	-1.36	4734.85
9600		1	129	0.16	9615.38
12500		1	99	0.00	12500.00
14400		1	86	-0.22	14367.82
19200		1	64	0.16	19230.77
28800		1	42	0.94	29069.77
31250		1	39	0.00	31250.00
38400		1	32	-1.36	37878.79
57600		1	21	-1.36	56818.18
62500		1	19	0.00	62500.00
115200		1	10	-1.36	113636.36
125000		1	9	0.00	125000.00
250000		1	4	0.00	250000.00
500000		1	2	-16.67	416666.67
625000		1	1	0.00	625000.00
1000000		—	—	—	—
1250000		1	0	0.00	1250000.00

In the UART mode, the value to be set in the baud rate register can be calculated as follows:

$$\text{BRG setting value} = \frac{f(\text{BCLK})}{\text{Baud rate (bps)} \times \text{clock divider frequency division value} \times 16} - 1$$

- f (BCLK) : Peripheral clock operating frequency
- Baud rate register setting value (BRG) : H'00 to H'FF
- Clock divider frequency division value : 1, 8, 32, 256

For details of the serial interface, refer to the 32176 Group User's Manual.

## 4. Sample Program Using the Serial Interface

### 4.1 Outline of the Sample Program

In the sample program, data is output from the SIO0 and data is received on the SIO1. Both communications use 8-bit UART. For transmission, data for the number of transmission bytes is transmitted from the address of the transmit data storage area specified by the parameter. For reception, interrupt processing is used. By connecting the SIO0 and the SIO1, full duplex communication is enabled by the on-chip UART functions of the 32176.

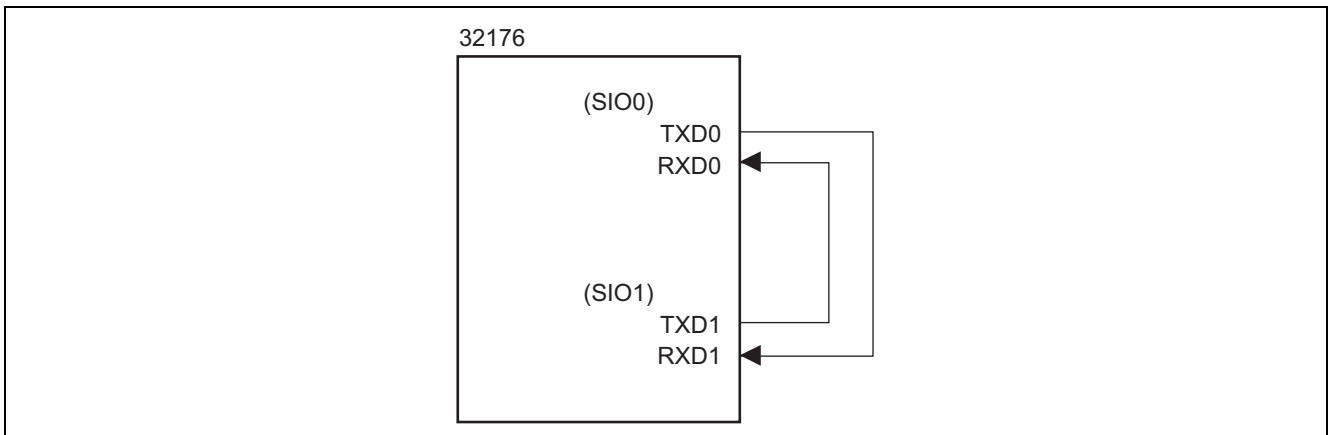

**Figure 4.1.1 Connection Diagram**

## 4.2 Transmit/Receive Processing

The flowchart for the initial settings of transmission and reception in the UART mode is shown in figure 4.2.1.

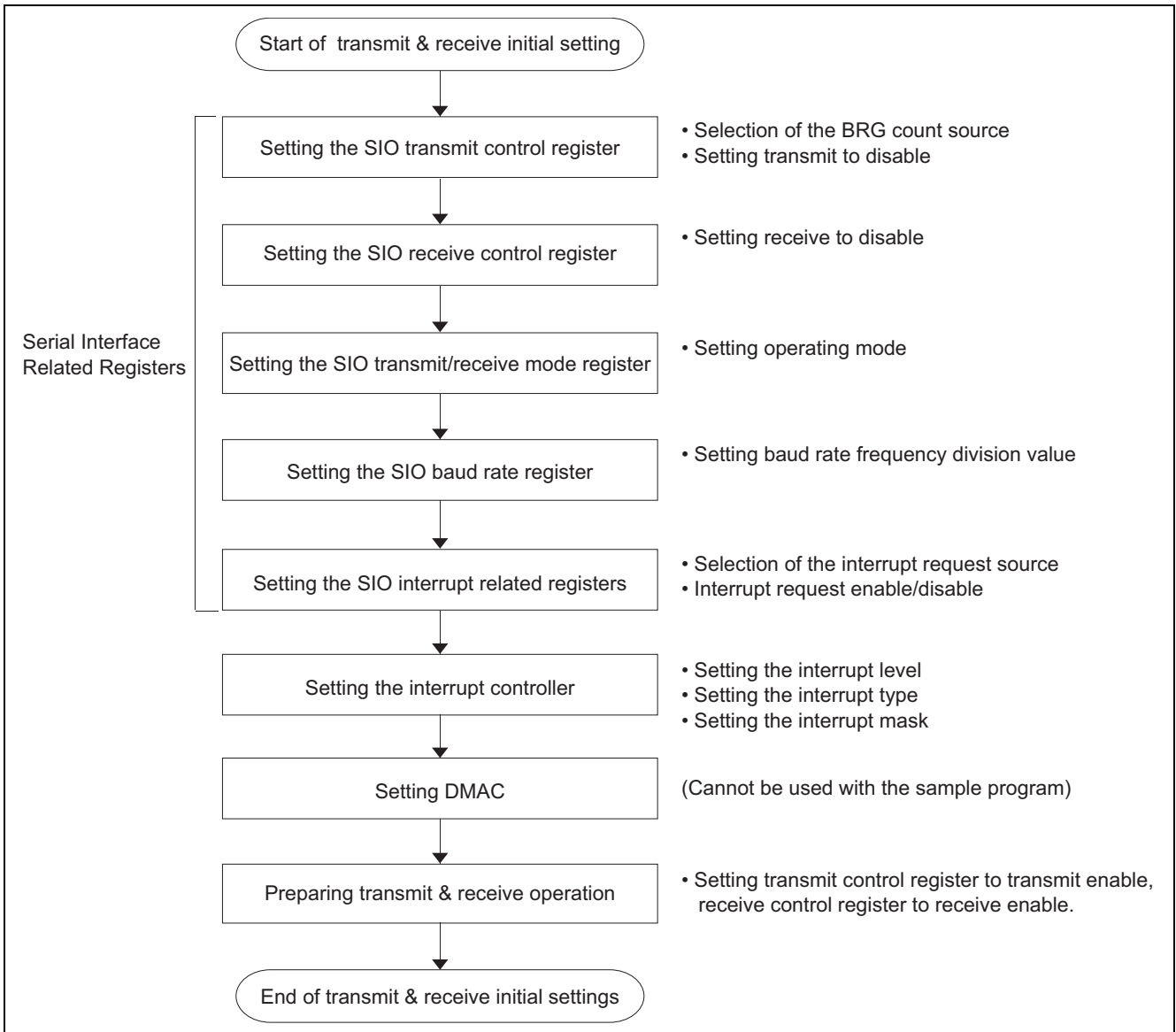

Figure 4.2.1 Flowchart for the Initial Settings of Transmission and Reception in the UART Mode

### 4.3 Description of the Sample Program

Note: Registers used are indicated as (register name: bit name).

#### 4.3.1 Various Initialization Function (init\_func ())

(1) Call the function for port initialization.

#### 4.3.2 Port Initialization Function (port\_init ())

(1) Set the output port.

- Set the port input enable bit of the port input special function control register to input enabled. (PICNT: PIEN0)
- Initialize the P11 data register. (P11DATA)
- Set the P11 direction register to the output mode. (P11DIR)
- Set the P11 operation mode register to input/output port. (P11MOD)

Note: Setting a direction register to output before setting the corresponding data register, causes undefined values to be output until the data register is written to.

#### 4.3.3 Main Function (main ())

(1) Initialize local variables.

- Received data buffer pointer (rx\_cnt1), previous received data buffer pointer (rx\_cnt1\_bak), and transmission data (send\_data) are initialized to "0".

(2) Call the function for disabling interrupts.

(3) Call the function for various initialization.

(4) Call the function for SIO0 transmit processing initialization.

(5) Call the function for SIO1 receive processing initialization.

(6) Call the function for enabling interrupts.

(7) Transmit/receive processing infinite loop.

- Transmit one byte of variable send\_data from SIO0.
- Wait for the SIO1 receive interrupt.
- Retrieve received data from SIO1 receive data buffer.
- Re-set to 0 when the SIO1 receive data buffer pointer overflow occurs.
- Store the current receive data buffer pointer.
- When SIO0 transmission data and SIO1 received data have the same value:
  - 1) Displays the received data on LED.
  - 2) Increments the transmission data and start next transmission processing.
- When SIO0 transmission data and SIO1 received data differ:
  - 1) Enters an infinite loop, and displays H'55 and H'AA alternatively on the LED.

#### 4.3.4 SIO0 Initialization Function (SIO0\_init ())

##### (1) Setting the transfer mode.

- Set the receive enable bit of the SIO0 receive control register to receive disabled. (S0RCNT: REN)
- Set the SIO0 transmit control register. (S0TCNT: CDIV, TEN)  
Set the BRG count source is set to f (BCLK), transmission disabled.
- Set the P8 operation mode register. (P8MOD: P82MOD, P83MOD)  
Set port P82 to TXD0, and port P83 to RXD0.
- Set the SIO0 transmit/receive mode register. (S0MOD: SMOD, CKS, STB, PEN, SEN)  
Set the 8-bit UART using the internal clock, with one stop bit, parity disabled, sleep function invalid.
- Set the baud rate frequency division value to SIO0 baud rate register. (S0BAUR)

##### (2) Interrupt settings.

- Set the interrupt level in the SIO0 transmission interrupt control register to interrupt disabled. (ISIO0TXCR: ILEVEL)
- Set the interrupt level in the SIO0 receive interrupt control register to “0” (highest priority). (ISIO0RXCR: ILEVEL)
- Set the SIO0 receive interrupt request source select bit of the SIO03 interrupt request source select register to reception finished interrupt. (SI03SEL: ISR0)
- Set the SIO03 interrupt request mask register. (SI03MASK: T0MASK, R0MASK)  
Disable SIO0 transmit interrupts, and enable SIO0 receive interrupts.

##### (3) Setting to enable transmission and reception.

- Set the transmit enable bit of the SIO0 transmit control register to transmit enabled. (S0TCNT: TEN)
- Set the receive enable bit of the SIO0 receive control register to receive enabled. (S0RCNT: REN)

#### 4.3.5 SIO1 Initialization Function (SIO1\_init ())

##### (1) Setting the transfer mode.

- Set the receive enable bit of the SIO1 receive control register to receive disabled. (S1RCNT: REN)
- Set the SIO1 transmit control register. (S0TCNT: CDIV, TEN)  
Set the BRG count source to f (BCLK), transmit disabled.
- Set the P8 operation mode register. (P8MOD: P85MOD, P86MOD)  
Set the port P85 to TXD1, and port P86 to RXD1.
- Set the SIO1 transmit/receive mode register. (S1MOD: SMOD, CKS, STB, PEN, SEN)  
Set the 8-bit UART using the internal clock, with one stop bit, parity disabled, sleep function invalid.
- Set the baud rate frequency division value in the SIO1 baud rate register. (S1BAUR)

##### (2) Interrupt settings.

- Set the interrupt level in the SIO1 transmission interrupt control register to interrupts disabled. (ISIO1TXCR:ILEVEL)
- Set the interrupt level in the SIO1 receive interrupt control register to “0” (highest priority). (ISIO1RXCR:ILEVEL)
- Set the SIO1 receive interrupt request source select bit of the SIO03 interrupt request source select register to reception finished interrupt. (SI03SEL: ISR1)
- Set the SIO03 interrupt request mask register. (SI03MASK: T1MASK, R1MASK)  
Disable SIO1 transmit interrupts, and enable SIO1 reception interrupts.

##### (3) Enable transmission and reception.

- Set the transmit enable bit of the SIO1 transmit control register to transmission enabled. (S1TCNT: TEN)
- Set the receive enable bit of the SIO1 receive control register to reception enabled. (S1RCNT: REN)

#### 4.3.6 SIO2 Initialization Function (SIO2\_init ())

Set in the same way as SIO0\_init.

Note: This function is not used in this sample program.

#### 4.3.7 SIO3 Initialization Function (SIO3\_init ())

Set in the same way as SIO0\_init.

Note: This function is not used in this sample program.

#### 4.3.8 UART Transmit Processing Function (SIO0\_Tr (), SIO1\_Tr (), SIO2\_Tr (), SIO3\_Tr ())

(1) Transmit processing.

- Confirm that the SIO transmit buffer is empty. (S0TCNT: TBE)
- Write one byte data of transmission data buffer to transmit buffer register. (S0TXB\_L)
- Repeat transmission for a specified number of times.
- Wait for SIO transmit completion. (S0TCNT: TSTAT)

Note: SIO1\_Tr (), SIO2\_Tr (), and SIO3\_Tr () are not used in this sample program.

#### 4.3.9 The UART Receive Processing Function by SIO Receive Interrupt (SIO0\_RcvInt (), SIO1\_RcvInt (), SIO2\_RcvInt (), SIO3\_RcvInt ())

(1) Receive processing.

- Read the SIO receive control register (receive status). (S1RCNT)
- Read the SIO receive buffer register. (S1RXB\_L)
- Re-read the SIO receive control register.  
For detecting overrun occurring between reading the receive status and reading the receive buffer register.
- Check SIO receive error sum bit. (S1RCNT: ERS)
  - 1) When no error occurs, the received data is stored in the receive data buffer and the pointer is incremented.
  - 2) When an error occurs, the receive enable bit is first set to receive disabled and then set to receive enabled.  
(Each bit in the receive control registers is cleared.)

Note: SIO0\_RcvInt (), SIO2\_RcvInt (), SIO3\_RcvInt () are not used in this sample program.

#### 4.3.10 Interrupt Handler Function of SIO2, 3 (IntHand\_SIO23 ())

Since the SIO2 and SIO3 interrupts are a group interrupt, which interrupt request occurred is determined by the interrupt request status bit of the SIO23 interrupt request status register.

(S123STAT: IRQR2, IRQR3)

Note: This function is not used in this sample program.

#### 4.3.11 Startup Routine (startup.ms)

(1) Interrupt settings.

- Set the start address of the SIO1 receive interrupt routine (SIO1\_RcvInt ()) in the SIO1 receive interrupt handler (H'0000 00CC) as the interrupt source in the ICU vector table.

## 4.4 Sample Program

The transmit/receive sample program for the UART mode is shown below.

Note that the sample program below requires the SFR definition file. The latest SFR definition file can be downloaded from Renesas Technology website. When using the SFR definitions file, adjust the path setting to match the operating computer environment.

### 4.4.1 uart\_main.c

```

1  /*"FILE COMMENT"*****
2  *      M32R C Programming          Rev. 1.01
3  *      < Sample Program for 32176 >
4  *      < Serial I/O (UART) (main routine) >
5  *
6  *      Copyright (c) 2004 Renesas Technology Corporation
7  *      All Rights Reserved
8  *      *****/
9
10 /*****
11 /*      Include file          */
12 /*****
13
14 #include          "..\inc\sfr32176_pragma.h"
15
16 /*****
17 /*      Function prototype declaration          */
18 /*****
19
20         void          main(void);          /* Main function */
21         void          init_func(void);     /* Initial setup function */
22         void          port_init(void);     /* Initialize port */
23
24 /*****
25 /*      Definition of external reference          */
26 /*****
27
28 extern void          DisInt( void );      /* Interrupt disable function
*/
29 extern void          EnInt( void );      /* Interrupt enable function
*/
30
31 extern void          SIO0_init( void);    /* Initialize SIO0 */
32 extern void          SIO1_init( void);    /* Initialize SIO1 */
33 extern void          SIO0_Tr( UCHAR *TrBuf, ULONG TrNum); /* Transmit from SIO0 */
34 extern void          SIO1_Tr( UCHAR *TrBuf, ULONG TrNum); /* Transmit from SIO1 */
35
36 /*      Global variable          */
37 /*      Global variable          */
38 /*****
39
40         volatile UCHAR RcvBuf0[10];      /* Receive buffer */
41         volatile UCHAR RcvBuf1[10];      /* Receive buffer */
42         volatile UCHAR RcvBuf2[10];      /* Receive buffer */
43         volatile UCHAR RcvBuf3[10];      /* Receive buffer */
44         volatile UCHAR rx_cnt0;          /* Pointer to receive buffer
*/
45         volatile UCHAR rx_cnt1;          /* Pointer to receive buffer
*/
46         volatile UCHAR rx_cnt2;          /* Pointer to receive buffer
*/
47         volatile UCHAR rx_cnt3;          /* Pointer to receive buffer
*/
48
49 /*"FUNC COMMENT"*****
50 *      Function name: init_func()
51 *      -----
52 *      Description   : Call various initialization functions
53 *      -----
54 *      Argument      : -
55 *      -----
56 *      Returns       : -
57 *      -----

```

```

58  * Notes      : -
59  *""FUNC COMMENT END""*****/
60 void init_func(void)
61 {
62     port_init();          /* Initialize port */
63 }
64
65 /""FUNC COMMENT""*****
66 * Function name: port_init()
67 *-----
68 * Description  : Port initialization
69 *-----
70 * Argument    : -
71 *-----
72 * Returns     : -
73 *-----
74 * Notes      : -
75 *""FUNC COMMENT END""*****/
76 void port_init(void)
77 {
78     PICNT = PIEN0;        /* Enable port input */
79
80     /** LED output port **/
81
82     P11DATA = 0x00;        /* Output data(must be set
prior to mode)*/
83     P11DIR = 0xff;        /* P110-P117 : Output mode */
84     P11MOD = 0x00;        /* P110-P117 : Input/output
port */
85 }
86
87 /""FUNC COMMENT""*****
88 * Function name: main()
89 *-----
90 * Description  : Receives data (increment pattern) from SIO1 after being transmitted in 500
Kbps clock-synchronized
91 *              : serial mode (when the source clock frequency = 10 MHz) from SIO0 and
92 *              : if the received data is the same as transmitted, displays it on LED(port
11).
93 *              : If unable to receive the same data, it displays 0x55 in blinking inverse
video.
94 *-----
95 * Argument    : -
96 *-----
97 * Returns     : -
98 *-----
99 * Notes      : -
100 *""FUNC COMMENT END""*****/
101 void main(void)
102 {
103     /*
104     *
105     *      (SIO0) | TXD0 | --+
106     *              |   | |
107     *              |   | |
108     *      (SIO1) | RXD1 | <--+
109     *              |   | |
110     *      (SIO1) | TXD1 | --+
111     *              |   | |
112     *              |   | | (not use)
113     *      (SIO0) | RXD0 | <--+
114     *              |   | |
115     *              +-----+
116     SI03MASK &= ~TOMASK;          /*Disable SIO0 transmit
interrupt request*/
117
118     ULONG    j;
119     UCHAR    send_data;
120     UCHAR    rcv_data;
121     UCHAR    rx_cnt1_bak;
122
123     rx_cnt1 = 0;
124     rx_cnt1_bak = 0;
125
126     send_data = 0;
127
128     DisInt();          /* Disable interrupt */

```

```

129
130     init_func();                                /* Initialize microcomputer
*/
131
132     SIO0_init();                                /* Initialize SIO0 */
133     SIO1_init();                                /* Initialize SIO1 */
134
135     EnInt();                                    /* Enable interrupt */
136
137     while(1) {
138         SIO0_Tr( &send_data, 1ul);              /* Send data from SIO0 */
139
140         while( rx_cnt1 == rx_cnt1_bak){         /* Wait for data to receive
*/
141             ;
142         }
143         rcv_data = RcvBuf1[ rx_cnt1 - 1];       /* Read out received data */
144
145         if( rx_cnt1 == 10) {                   /* Check for receive counter
overflow */
146             rx_cnt1 = 0;
147         }
148         rx_cnt1_bak = rx_cnt1;
149
150         if( rcv_data == send_data) {
151             P11DATA = rcv_data;                /* Display received
(transmitted) data */
152             send_data++;                        /* Increment transmit data */
153         } else {                                /* Received data in error */
154             P11DATA = 0x55;
155             while(1) {
156                 for( j = 0ul; j < 1000000ul; j++){ /* Wait */
157                     ;
158                 }
159                 P11DATA ^= 0xffu;              /* Display 0x55 in blinking
inverse video*/
160             }
161         }
162     }
163 }

```

#### 4.4.2 uart.c

```

1  /*****"FILE COMMENT"*****/
2  *      M32R C Programming          Rev. 1.01
3  *      < Sample Program for 32176 >
4  *      < Serial Interface (UART) >
5  *
6  *      Copyright (c) 2004 Renesas Technology Corporation
7  *      All Rights Reserved
8  *****/
9
10 /*****/
11 /*      Include file                */
12 /*****/
13
14 #include          "..\inc\sfr32176_pragma.h"
15
16 /*****/
17 /*      Function prototype declaration */
18 /*****/
19
20 void          SIO0_init( void);          /* Initialize SIO0 */
21 void          SIO1_init( void);          /* Initialize SIO1 */
22 void          SIO2_init( void);          /* Initialize SIO2 */
23 void          SIO3_init( void);          /* Initialize SIO3 */
24 void          SIO0_Tr( UCHAR *TrBuf, ULONG TrNum); /* Transmit from SIO0 */
25 void          SIO1_Tr( UCHAR *TrBuf, ULONG TrNum); /* Transmit from SIO1 */
26 void          SIO2_Tr( UCHAR *TrBuf, ULONG TrNum); /* Transmit from SIO2 */
27 void          SIO3_Tr( UCHAR *TrBuf, ULONG TrNum); /* Transmit from SIO3 */
28 void          SIO0_RcvInt( void);        /* SIO0 receive interrupt */
29 void          SIO1_RcvInt( void);        /* SIO1 receive interrupt */
30 void          SIO2_RcvInt( void);        /* SIO2 receive interrupt */
31 void          SIO3_RcvInt( void);        /* SIO3 receive interrupt */
32 void          IntHand_SIO23( void);      /* SIO2,3 transmit/receive
interrupt handler */
33
34 /*****/
35 /*      Externally referenced variable */
36 /*      Global variable                */
37
38 extern volatile UCHAR RcvBuf0[];        /* Receive buffer */
39 extern volatile UCHAR RcvBuf1[];        /* Receive buffer */
40 extern volatile UCHAR RcvBuf2[];        /* Receive buffer */
41 extern volatile UCHAR RcvBuf3[];        /* Receive buffer */
42 extern volatile UCHAR rx_cnt0;          /* Pointer to receive buffer
*/
43 extern volatile UCHAR rx_cnt1;          /* Pointer to receive buffer
*/
44 extern volatile UCHAR rx_cnt2;          /* Pointer to receive buffer
*/
45 extern volatile UCHAR rx_cnt3;          /* Pointer to receive buffer
*/
46
47 /*****/
48 /*      Define macro                    */
49 /*****/
50
51 /* Setting port operation mode */
52
53 #define P8MOD_SCI0          0x30u          /* 0123 4567 */
register          /* 0011 0000B P8 operation mode
54          /* |||| |||+--- P87
55          /* |||| ||+---- P86
56          /* |||| |+----- P85
57          /* |||| +----- P84
58          /* |||+----- RXD0
59          /* ||+----- TXD0
60          /* ++----- don't care
61

```

```

62
63 #define P8MOD_SCI1      0x06u
register */
64
65
66
67
68
69
70
71
72
73 #define P17MOD_SCI2    0x0cu
register */
74
75
76
77
78
79
80
81
82
83 #define P17MOD_SCI3    0x03u
register */
84
85
86
87
88
89
90
91
92 /* Setting serial IO */
93
94 #define SnTCNT_INI      0x00u
register */
95
96
97
98
99
100
101 #define SnMOD_INI       0x20u
*/
102
103 disabled */
104
*/

```

```

/* 0123 4567 */
/* 0000 0110B P8 operation mode
/* |||| |||+---- P87
*/
/* |||| ||+---- RXD1
*/
/* |||| |+----- TXD1
*/
/* |||| +----- P84
*/
/* |||+----- P83
*/
/* ||+----- P82
*/
/* ++----- don't care
*/
/* 0123 4567 */
/* 0000 1100B P17 operation mode
/* |||| |||+---- P177
*/
/* |||| ||+---- P176
*/
/* |||| |+----- RXD2
*/
/* |||| +----- TXD2
*/
/* |||+----- P173
*/
/* ||+----- P172
*/
/* ++----- don't care
*/
/* 0123 4567 */
/* 0000 0011B P17 operation mode
/* |||| |||+---- RXD3
*/
/* |||| ||+---- TXD3
*/
/* |||| |+----- P175
*/
/* |||| +----- P174
*/
/* |||+----- P173
*/
/* ||+----- P172
*/
/* ++----- don't care
*/
/* 0123 4567 */
/* 0000 0000B SION transmit control
/* |||| |||+---- Disable transmission
*/
/* |||| +++----- don't care
*/
/* ||+----- f(BCLK)
*/
/* ++----- don't care
*/
/* 0123 4567 */
/* 0010 0000B SION mode register
*/
/* |||| |||+---- Sleep function
*/
/* |||| ||+---- Parity inhibited
*/
/* |||| |+----- don't care (odd)
*/

```

```

105                                     /* |||| +----- 1 stop bit
*/
106                                     /* |||+----- Internal clock
*/
107                                     /* +++----- 8-bit UART
*/
108
109 /* Setting interrupt priority level */
110
111 #define SioILEVEL          0x0u          /* Serial IO transmit/receive
interrupt priority level*/
112 #define ILEVEL_7          0x7u          /* Interrupt Disable
*/
113
114 /* Setting baud rate (Be sure to check actually set value when using) */
115
116 #define XIN                10           /* 10MHz */
117
118 #define BAUD_62_5          (XIN * 2000000 / 16 / 62500 - 1)      /* 62.5Kbps */
119 #define BAUD_15_6          (XIN * 2000000 / 16 / 15600 - 1)      /* 15.6Kbps */
120 #define BAUD_9615          (XIN * 2000000 / 16 / 9615 - 1)      /* 9615bps */
121
122
123 /*"FUNC COMMENT"*****
124 * Function name: SIO0_init()
125 *-----
126 * Description   : Sets SIO0 for 8-bit UART
127 *               : - Reception by interrupt
128 *               : - Program transmission
129 *-----
130 * Argument      : -
131 *-----
132 * Returns       : -
133 *-----
134 * Notes         : Port input function must be enabled
135 *               : Must be executed while interrupts are disabled
136 *"FUNC COMMENT END"*****
137 void SIO0_init( void)
138 {
139
140 /*** Setting transfer mode */
141
142     SORCNT = 0x00;          /* Disable reception */
143     SOTCNT = SnTCNT_INI;   /* f(BCLK) and disable
transmission */
144     P8MOD |= P8MOD_SCI0;   /* Set P8 for SIO mode */
145     SOMOD = SnMOD_INI;     /* Set data format */
146     SOBAUR = BAUD_62_5;    /* Set baud rate */
147
148 /*** Interrupt related settings ***/
149
150     ISIO0TXCR = ILEVEL_7;  /* Set SIO0 transmit interrupt
priority level*/
151     ISIO0RXCR = SioILEVEL; /* Set SIO0 receive interrupt
priority level */
152     SI03SEL &= ~ISR0;     /* Select receive-finished
interrupt */
153     SI03MASK &= ~TOMASK;  /* Disable SIO0 transmit
interrupt request */
154     SI03MASK |= ROMASK;    /* Enable SIO0 receive
interrupt request */
155
156 /*** Starting transmission/reception ***/
157
158     SOTCNT |= TEN;         /* Enable transmission */
159     SORCNT |= REN;         /* Enable reception */
160 }
161
162 /*"FUNC COMMENT"*****
163 * Function name: SIO1_init()
164 *-----
165 * Description   : Sets SIO1 for 8-bit UART
166 *               : - Reception by interrupt
167 *               : - Program transmission
168 *-----
169 * Argument      : -
170 *-----

```

```

171  * Returns      : -
172  *-----
173  * Notes        : Port input function must be enabled
174  *              : Must be executed while interrupts are disabled
175  *""FUNC COMMENT END""*****
176 void    SIO1_init( void)
177 {
178
179  /*** Setting transfer mode */
180
181          S1RCNT = 0x00;                /* Disable reception */
182          S1TCNT = SnTCNT_INI;        /* f(BCLK) and disable
transmission */
183          P8MOD |= P8MOD_SCI1;        /* Set P8 for SIO mode */
184          S1MOD = SnMOD_INI;         /* Set data format */
185          S1BAUR = BAUD_62_5;        /* Set baud rate */
186
187  /*** Interrupt related settings ***/
188
189          ISIO1TXCR = ILEVEL_7;       /* Set SIO1 transmit interrupt
priority level*/
190          ISIO1RXCR = SioILEVEL;     /* Set SIO1 receive interrupt
priority level */
191          SI03SEL &= ~ISR1;          /* Select receive-finished
interrupt */
192          SI03MASK &= ~T1MASK;       /* Disable SIO1 transmit
interrupt request */
193          SI03MASK |= R1MASK;        /* Enable SIO1 receive
interrupt request */
194
195  /*** Starting transmission/reception ***/
196
197          S1TCNT |= TEN;              /* Enable transmission */
198          S1RCNT |= REN;              /* Enable reception */
199  }
200
201  /""FUNC COMMENT""*****
202  * Function name: SIO2_init()
203  *-----
204  * Description   : Sets SIO2 for 8-bit UART
205  *               : - Reception by interrupt
206  *               : - Program transmission
207  *-----
208  * Argument      : -
209  *-----
210  * Returns       : -
211  *-----
212  * Notes         : Port input function must be enabled
213  *               : Must be executed while interrupts are disabled
214  *               : Interrupt priority levels are common to both SIO2,3 transmission and
reception
215  *""FUNC COMMENT END""*****
216 void    SIO2_init( void)
217 {
218
219  /*** Setting transfer mode */
220
221          S2RCNT = 0x00;                /* Disable reception */
222          S2TCNT = SnTCNT_INI;        /* f(BCLK) and disable
transmission */
223          P17MOD |= P17MOD_SCI2;     /* Set P17 for SIO mode */
224          S2MOD = SnMOD_INI;         /* Set data format */
225          S2BAUR = BAUD_62_5;        /* Set baud rate */
226
227  /*** Interrupt related settings ***/
228
229          ISIO23CR = SioILEVEL;       /* Set SIO2,3 transmission
and reception interrupt priority level */
230          SI03SEL &= ~ISR2;          /* Select receive-finished
interrupt */
231          SI03MASK &= ~T2MASK;       /* Disable SIO2 transmit
interrupt request */
232          SI03MASK |= R2MASK;        /* Enable SIO2 receive
interrupt request */
233          SI23STAT = (~( IRQT2 | IRQR2)) & 0x0fu; /* Clear interrupt request */
234
235  /*** Starting transmission/reception ***/

```

```

236
237         S2TCNT |= TEN;                /* Enable transmission */
238         S2RCNT |= REN;                /* Enable reception */
239     }
240
241     /*"FUNC COMMENT"*****
242     * Function name: SIO3_init()
243     *-----
244     * Description   : Sets SIO3 for 8-bit UART
245     *               : - Reception by interrupt
246     *               : - Program transmission
247     *-----
248     * Argument     : -
249     *-----
250     * Returns      : -
251     *-----
252     * Notes        : Port input function must be enabled
253     *               : Must be executed while interrupts are disabled
254     *               : Interrupt priority levels are common to both SIO2,3 transmission and
reception
255     *"FUNC COMMENT END"*****/
256     void SIO3_init( void)
257     {
258
259     /** Setting transfer mode */
260
261         S3RCNT = 0x00;                /* Disable reception */
262         S3TCNT = SnTCNT_INI;        /* f(BCLK) and disable
transmission */
263         P17MOD |= P17MOD_SCI3;      /* Set P17 for SIO mode */
264         S3MOD = SnMOD_INI;          /* Set data format */
265         S3BAUR = BAUD_62_5;        /* Set baud rate */
266
267     /** Interrupt related settings */
268
269         ISIO23CR = SioILEVEL;        /* Set SIO2,3 transmission
and reception interrupt priority level */
270         SIO3SEL &= ~ISR3;          /* Select receive-finished
interrupt */
271         SIO3MASK &= ~T3MASK;       /* Disable SIO3 transmit
interrupt request */
272         SIO3MASK |= R3MASK;        /* Enable SIO3 receive
interrupt request */
273         SI23STAT = (~( IRQT3 | IRQR3)) & 0x0fu; /* Clear interrupt request */
274
275     /** Starting transmission/reception */
276
277         S3TCNT |= TEN;                /* Enable transmission */
278         S3RCNT |= REN;                /* Enable reception */
279     }
280
281     /*"FUNC COMMENT"*****
282     * Function name: SIO0_Tr()
283     *-----
284     * Description   : Transmits data from SIO0
285     *-----
286     * Argument     : unsigned char *TrBuf  Pointer to transmit data buffer
287     *               : unsigned int TrNum   Number of transmit bytes
288     *-----
289     * Returns      : -
290     *-----
291     * Notes        : Do not always need to wait for end of transmission
292     *"FUNC COMMENT END"*****/
293     void SIO0_Tr( UCHAR *TrBuf, ULONG TrNum)
294     {
295         ULONG   i;
296
297         for( i = 0ul; i < TrNum; i++) {
298             while(( S0TCNT & TBE) == 0u){ /* Wait until transmit buffer
is empty */
299                 ;
300             }
301             S0TXB_L = *TrBuf++;          /* Transfer return data */
302         }
303         while(( S0TCNT & TSTAT) != 0u){ /* Wait for end of
transmission */
304             ;

```

```

305     }
306 }
307
308 /*****FUNC COMMENT*****/
309 * Function name: SIO1_Tr()
310 *-----
311 * Description   : Transmits data from SIO1
312 *-----
313 * Argument      : unsigned char *TrBuf  Pointer to transmit data buffer
314 *                : unsigned int TrNum   Number of transmit bytes
315 *-----
316 * Returns       : -
317 *-----
318 * Notes         : Do not always need to wait for end of transmission
319 *****/
320 void SIO1_Tr( UCHAR *TrBuf, ULONG TrNum)
321 {
322     ULONG i;
323
324     for( i = 0ul; i < TrNum; i++) {
325         while(( S1TCNT & TBE) == 0u){           /* Wait until transmit buffer
is empty */
326             ;
327         }
328         S1TXB_L = *TrBuf++;                     /* Transfer return data */
329     }
330     while(( S1TCNT & TSTAT) != 0u){           /* Wait for end of
transmission */
331         ;
332     }
333 }
334
335 /*****FUNC COMMENT*****/
336 * Function name: SIO2_Tr()
337 *-----
338 * Description   : Transmits data from SIO2
339 *-----
340 * Argument      : unsigned char *TrBuf  Pointer to transmit data buffer
341 *                : unsigned int TrNum   Number of transmit bytes
342 *-----
343 * Returns       : -
344 *-----
345 * Notes         : Do not always need to wait for end of transmission
346 *****/
347 void SIO2_Tr( UCHAR *TrBuf, ULONG TrNum)
348 {
349     ULONG i;
350
351     for( i = 0ul; i < TrNum; i++) {
352         while(( S2TCNT & TBE) == 0u){           /* Wait until transmit buffer
is empty */
353             ;
354         }
355         S2TXB_L = *TrBuf++;                     /* Transfer return data */
356     }
357     while(( S2TCNT & TSTAT) != 0u){           /* Wait for end of
transmission */
358         ;
359     }
360 }
361
362 /*****FUNC COMMENT*****/
363 * Function name: SIO3_Tr()
364 *-----
365 * Description   : Transmits data from SIO3
366 *-----
367 * Argument      : unsigned char *TrBuf  Pointer to transmit data buffer
368 *                : unsigned int TrNum   Number of transmit bytes
369 *-----
370 * Returns       : -
371 *-----
372 * Notes         : Do not always need to wait for end of transmission
373 *****/
374 void SIO3_Tr( UCHAR *TrBuf, ULONG TrNum)
375 {
376     ULONG i;
377

```

```

378         for( i = 0ul; i < TrNum; i++) {
379             while(( S3TCNT & TBE) == 0u){                /* Wait until transmit buffer
is empty */
380                 ;
381             }
382             S3TXB_L = *TrBuf++;                            /* Transfer return data */
383         }
384         while(( S3TCNT & TSTAT) != 0u){                /* Wait for end of
transmission */
385             ;
386         }
387     }
388
389     /*"FUNC COMMENT"*****
390     * Function name: SIO0_RcvInt()
391     *-----
392     * Description   : Reads out received data
393     *-----
394     * Argument     : -
395     *-----
396     * Returns      : -
397     *-----
398     * Notes        : -
399     *"FUNC COMMENT END"*****/
400 void    SIO0_RcvInt(void)
401 {
402     UCHAR    data;
403     UCHAR    status;
404
405     status = S0RCNT;                                     /* Read receive status */
406     data = S0RXB_L;                                    /* Read out received data */
407     status |= S0RCNT;                                  /* Handle overrun */
408
409     if(( status & ERS) == 0u) {                        /* Check receive error sum */
410         RcvBuf0[ rx_cnt0++] = data;                   /* Store received data */
411     } else {                                           /* Disable reception */
412
413         /* Error processing by user */
414
415         S0RCNT &= ~REN;                                /* Disable reception */
416         S0RCNT |= REN;                                /* Enable reception */
417     }
418 }
419
420
421 /*"FUNC COMMENT"*****
422 * Function name: SIO1_RcvInt()
423 *-----
424 * Description   : Reads out received data
425 *-----
426 * Argument     : -
427 *-----
428 * Returns      : -
429 *-----
430 * Notes        :
431 *"FUNC COMMENT END"*****/
432 void    SIO1_RcvInt(void)
433 {
434     UCHAR    data;
435     UCHAR    status;
436
437     status = S1RCNT;                                     /* Read receive status */
438     data = S1RXB_L;                                    /* Read out received data */
439     status |= S1RCNT;                                  /* Handle overrun */
440
441     if(( status & ERS) == 0u) {                        /* Check receive error sum */
442         RcvBuf1[ rx_cnt1++] = data;                   /* Store received data */
443     } else {                                           /* Disable reception */
444
445         /* Error processing by user */
446
447         S1RCNT &= ~REN;                                /* Disable reception */
448         S1RCNT |= REN;                                /* Enable reception */
449     }
450 }
451 }
452

```

```

453 /*"FUNC COMMENT"*****
454 * Function name: SIO2_RcvInt()
455 *-----
456 * Description   : Reads out received data
457 *-----
458 * Argument     : -
459 *-----
460 * Returns      : -
461 *-----
462 * Notes       : -
463 /*"FUNC COMMENT END"*****/
464 void SIO2_RcvInt(void)
465 {
466     UCHAR data;
467     UCHAR status;
468
469     status = S2RCNT; /* Read receive status */
470     data = S2RXB_L; /* Read out received data */
471     status |= S2RCNT; /* Handle overrun */
472
473     if(( status & ERS) == 0u) { /* Check receive error sum */
474         RcvBuf2[ rx_cnt2++] = data; /* Store received data */
475     } else { /* Disable reception */
476
477         /* Error processing by user */
478
479         S2RCNT &= ~REN; /* Disable reception */
480         S2RCNT |= REN; /* Enable reception */
481     }
482 }
483
484 /*"FUNC COMMENT"*****
485 * Function name: SIO3_RcvInt()
486 *-----
487 * Description   : Reads out received data
488 *-----
489 * Argument     : -
490 *-----
491 * Returns      : -
492 *-----
493 * Notes       : -
494 /*"FUNC COMMENT END"*****/
495 void SIO3_RcvInt(void)
496 {
497     UCHAR data;
498     UCHAR status;
499
500     status = S3RCNT; /* Read receive status */
501     data = S3RXB_L; /* Read out received data */
502     status |= S3RCNT; /* Handle overrun */
503
504     if(( status & ERS) == 0u) { /* Check receive error sum */
505         RcvBuf3[ rx_cnt3++] = data; /* Store received data */
506     } else { /* Disable reception */
507
508         /* Error processing by user */
509
510         S3RCNT &= ~REN; /* Disable reception */
511         S3RCNT |= REN; /* Enable reception */
512     }
513 }
514
515 /*"FUNC COMMENT"*****
516 * Function name: IntHand_SIO23()
517 *-----
518 * Description   : Processing by SIO2,3 transmit/receive interrupt handlers
519 *-----
520 * Argument     : -
521 *-----
522 * Returns      : -
523 *-----
524 * Notes       : Transmit interrupt is not considering
525 /*"FUNC COMMENT END"*****/
526 void IntHand_SIO23(void)
527 {
528
529

```

```
530         if(( SI23STAT & IRQR3) != 0u) {                               /* Judge interrupt request */
531             SI23STAT = (~IRQR3) & 0x0fu;                             /* Clear interrupt request
status */
532             SIO3_RcvInt();                                           /* Process SIO3 receive
interrupt */
533         }
534
535         if(( SI23STAT & IRQR2) != 0u) {                               /* Judge interrupt request */
536             SI23STAT = (~IRQR2) & 0x0fu;                             /* Clear interrupt request
status */
537             SIO2_RcvInt();                                           /* Process SIO2 receive
interrupt */
538         }
539     }
540
```

### 4.4.3 startup.ms (partially omitted)

(Omitted)

```

69 ;*****
70 ; ICU Vector Table
71 ;*****
72 ;
73     .SECTION      ICUVECT, DATA, ALIGN=4
74 ;
75     .IMPORT      $$SIO1_RcvInt
76 ;
77 vectbl:
78     .DATA.W      EIT_reset      ; H'0000 0094  MJT Input Interrupt 4:TIN3-
TIN6
79     .DATA.W      EIT_reset      ; H'0000 0098  MJT Input Interrupt 3:TIN20-
TIN23
80     .DATA.W      EIT_reset      ; H'0000 009C  MJT Input Interrupt 2:TIN12-
TIN19
81     .DATA.W      EIT_reset      ; H'0000 00A0  MJT Input Interrupt 1:TIN0-
TIN2
82     .DATA.W      EIT_reset      ; H'0000 00A4  MJT Input Interrupt 0:TIN7-
TIN11
83     .DATA.W      EIT_reset      ; H'0000 00A8  MJT Output Interrupt
7:TMS0,TMS1
84     .DATA.W      EIT_reset      ; H'0000 00AC  MJT Output Interrupt
6:TOP8, TOP9
85     .DATA.W      EIT_reset      ; H'0000 00B0  MJT Output Interrupt 5:TOP10
86     .DATA.W      EIT_reset      ; H'0000 00B4  MJT Output Interrupt 4:TIO4-
TIO7
87     .DATA.W      EIT_reset      ; H'0000 00B8  MJT Output Interrupt
3:TIO8, TIO9
88     .DATA.W      EIT_reset      ; H'0000 00BC  MJT Output Interrupt 2:TOP0-
TOP5
89     .DATA.W      EIT_reset      ; H'0000 00C0  MJT Output Interrupt
1:TOP6, TOP7
90     .DATA.W      EIT_reset      ; H'0000 00C4  MJT Output Interrupt 0:TIO0-
TIO3
91     .DATA.W      EIT_reset      ; H'0000 00C8  DMAC0-4 Interrupt:DMA0-DMA4
92     .DATA.W      $$SIO1_RcvInt  ; H'0000 00CC  SIO1 Receive Interrupt
93     .DATA.W      EIT_reset      ; H'0000 00D0  SIO1 Transmit Interrupt
94     .DATA.W      EIT_reset      ; H'0000 00D4  SIO0 Receive Interrupt
95     .DATA.W      EIT_reset      ; H'0000 00D8  SIO0 Transmit Interrupt
96     .DATA.W      EIT_reset      ; H'0000 00DC  A-D0 Conversion Interrupt
97     .DATA.W      EIT_reset      ; H'0000 00E0  TID0 Output Interrupt
98     .DATA.W      EIT_reset      ; H'0000 00E4  TOD0 Output Interrupt
99     .DATA.W      EIT_reset      ; H'0000 00E8  DMAC5-9 Interrupt:DMA5-DMA9
100    .DATA.W      EIT_reset      ; H'0000 00EC  SIO2,3 Transmit/Receive
Interrupt
101    .DATA.W      EIT_reset      ; H'0000 00F0  RTD Interrupt
102    .DATA.W      EIT_reset      ; H'0000 00F4  TID1 Output Interrupt
103    .DATA.W      EIT_reset      ; H'0000 00F8  TOD1,TOM0 Output Interrupt
104    .DATA.W      EIT_reset      ; H'0000 00FC  SIO4,5 Transmit/Receive
Interrupt
105    .DATA.W      EIT_reset      ; H'0000 0100  A-D1 Conversion Interrupt
106    .DATA.W      EIT_reset      ; H'0000 0104  TID2 Output Interrupt
107    .DATA.W      EIT_reset      ; H'0000 0108  TML1 Input Interrupt
108    .DATA.W      EIT_reset      ; H'0000 010C  CAN0 Transmit/Receive & Error
Interrupt
109    .DATA.W      EIT_reset      ; H'0000 0110  CAN1 Transmit/Receive & Error
Interrupt
110 ;

```

(The remainder of the program has been omitted)

### 4.5 UART Operation Timing

The UART mode transmission and reception timing diagrams are shown below.

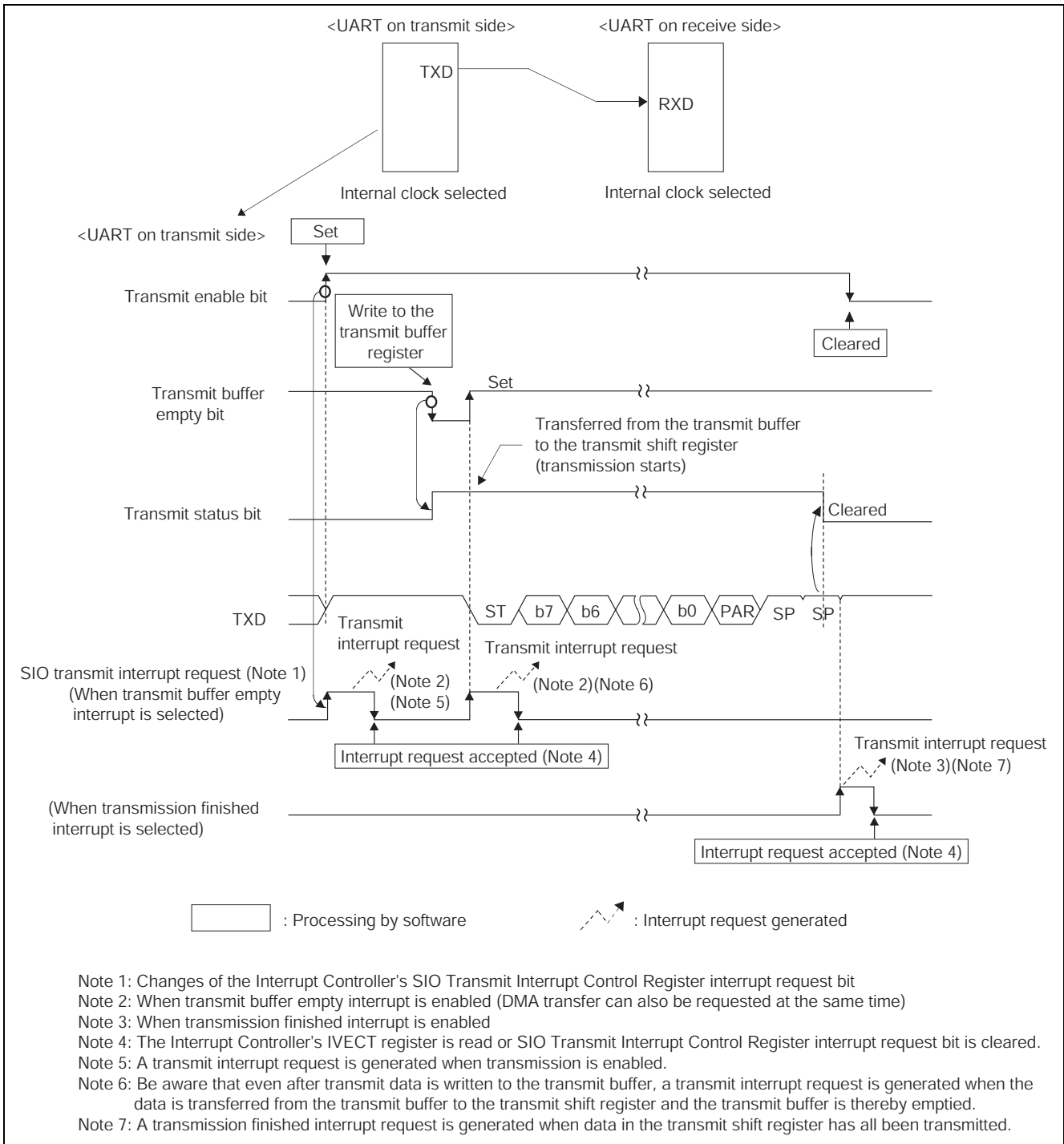

Figure 4.5.1 UART Mode Transmission Timing Diagram

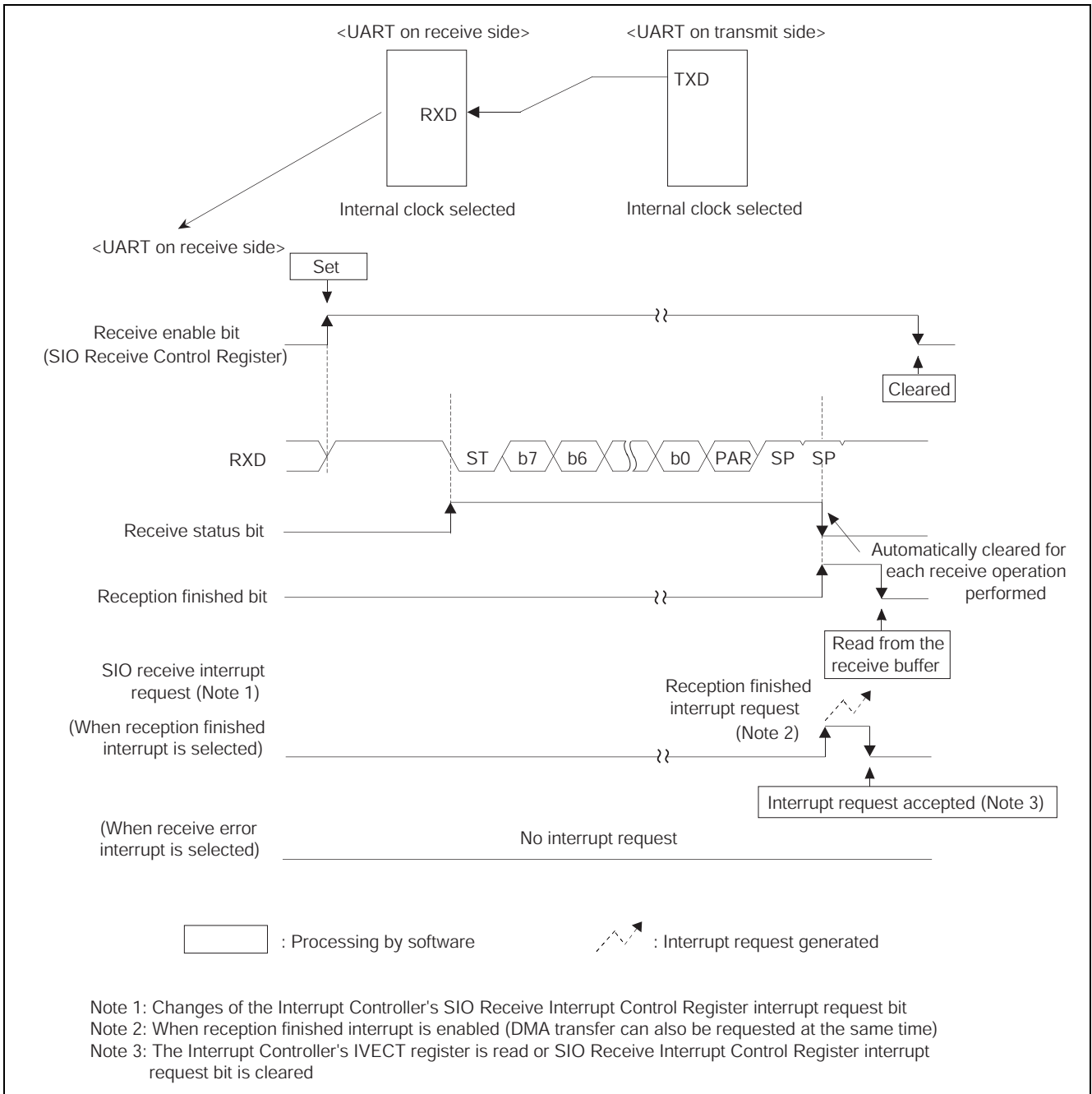

Figure 4.5.2 UART Mode Receive Timing Diagram

## 5. Reference Documents

- 32176 Group User's Manual (Rev.1.01)
- M32R Family Software Manual (Rev.1.20)
- M3T-CC32R V.4.30 User's Manual (Compiler)
- M3T-CC32R V.4.30 User's Manual (Assembler)

(Please get the latest one from Renesas Technology Corp. website.)

## 6. Website and Support Center

- Renesas Technology Corp. website.

<http://www.renesas.com/>

- Inquires for all Renesas products and technical inquiries for the M32R Family products, please contact:  
Customer Support Center: [csc@renesas.com](mailto:csc@renesas.com)

### Revision Record

Rev.	Date	Description	
		Page	Summary
1.00	Jan.12.06	—	First edition issued

Keep safety first in your circuit designs!

1. Renesas Technology Corporation puts the maximum effort into making semiconductor products better and more reliable, but there is always the possibility that trouble may occur with them. Trouble with semiconductors may lead to personal injury, fire or property damage. Remember to give due consideration to safety when making your circuit designs, with appropriate measures such as (i) placement of substitutive, auxiliary circuits, (ii) use of nonflammable material or (iii) prevention against any malfunction or mishap.

Notes regarding these materials

1. These materials are intended as a reference to assist our customers in the selection of the Renesas Technology Corporation product best suited to the customer's application; they do not convey any license under any intellectual property rights, or any other rights, belonging to Renesas Technology Corporation or a third party.
2. Renesas Technology Corporation assumes no responsibility for any damage, or infringement of any third-party's rights, originating in the use of any product data, diagrams, charts, programs, algorithms, or circuit application examples contained in these materials.
3. All information contained in these materials, including product data, diagrams, charts, programs and algorithms represents information on products at the time of publication of these materials, and are subject to change by Renesas Technology Corporation without notice due to product improvements or other reasons. It is therefore recommended that customers contact Renesas Technology Corporation or an authorized Renesas Technology Corporation product distributor for the latest product information before purchasing a product listed herein.  
The information described here may contain technical inaccuracies or typographical errors. Renesas Technology Corporation assumes no responsibility for any damage, liability, or other loss rising from these inaccuracies or errors.  
Please also pay attention to information published by Renesas Technology Corporation by various means, including the Renesas Technology Corporation Semiconductor home page (<http://www.renesas.com>).
4. When using any or all of the information contained in these materials, including product data, diagrams, charts, programs, and algorithms, please be sure to evaluate all information as a total system before making a final decision on the applicability of the information and products. Renesas Technology Corporation assumes no responsibility for any damage, liability or other loss resulting from the information contained herein.
5. Renesas Technology Corporation semiconductors are not designed or manufactured for use in a device or system that is used under circumstances in which human life is potentially at stake. Please contact Renesas Technology Corporation or an authorized Renesas Technology Corporation product distributor when considering the use of a product contained herein for any specific purposes, such as apparatus or systems for transportation, vehicular, medical, aerospace, nuclear, or undersea repeater use.
6. The prior written approval of Renesas Technology Corporation is necessary to reprint or reproduce in whole or in part these materials.
7. If these products or technologies are subject to the Japanese export control restrictions, they must be exported under a license from the Japanese government and cannot be imported into a country other than the approved destination.  
Any diversion or reexport contrary to the export control laws and regulations of Japan and/or the country of destination is prohibited.
8. Please contact Renesas Technology Corporation for further details on these materials or the products contained therein.