

---

# H8S/2200 Series

## Data Transfer in the Single-Address Mode

---

### Introduction

Uses the DMAC single-address mode to transfer data to an external device (H8S/2215). DMAC is started up at a falling edge of an external signal.

### Target Device

H8S/2239

### Contents

1. Specifications .....	2
2. Description of Functions .....	3
3. Principles of Operation.....	4
4. Description of Software.....	5
5. PAD.....	6

**1. Specifications**

1. As shown in figure 1, this sample task uses DMAC single-address mode to transfer data between the external space specified by a transfer source address or transfer destination address, and an external device that is selected by a DACK strobe independently of the address.
2. DMAC starts up at detection of a falling edge of an external signal.

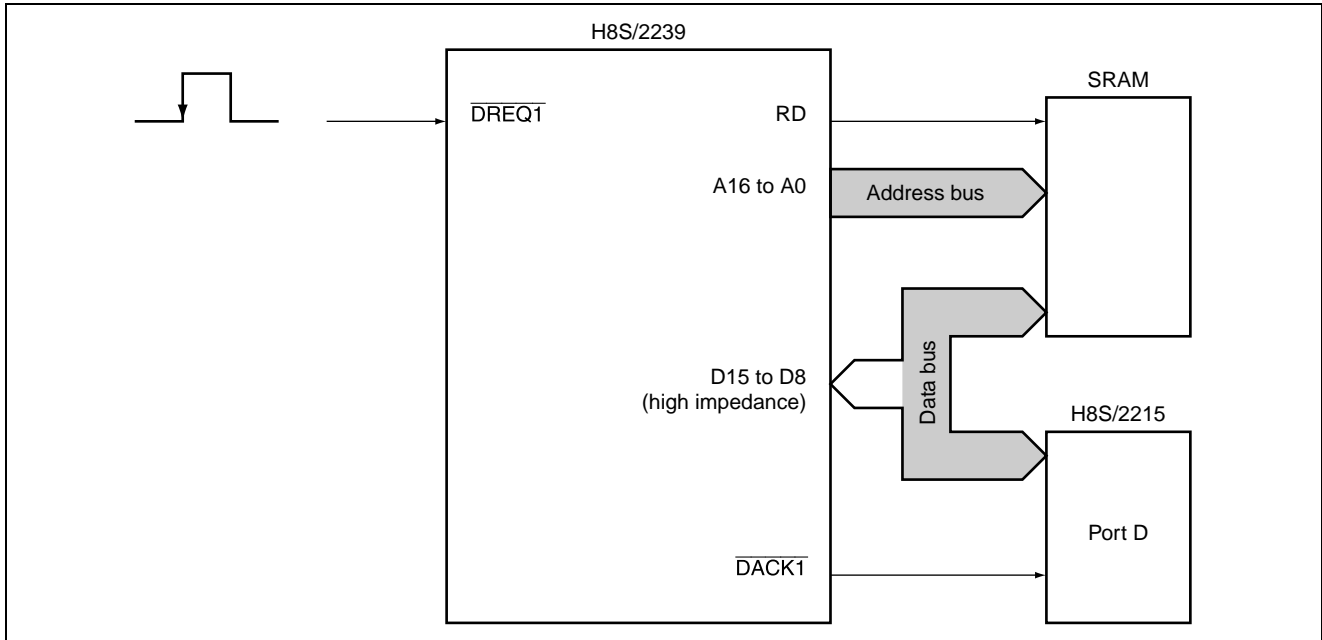

**Figure 1 Data Bus in the Single-Address Mode**

## 2. Description of Functions

1. This sample task uses the DMAC single-address mode (idle mode specification) to transfer data to the external device (H8S/2215) from the external memory (SRAM).

A. The block diagram of DMAC to be used in this sample task is shown in figure 2.

This sample task uses the following DMAC functions to transfer data blocks:

- Function that starts up DMAC on an external request (DMAC startup by DREQ)
- Function that transfers one byte or one word between the external memory and external device per transfer request as many times as specified (single-address mode)

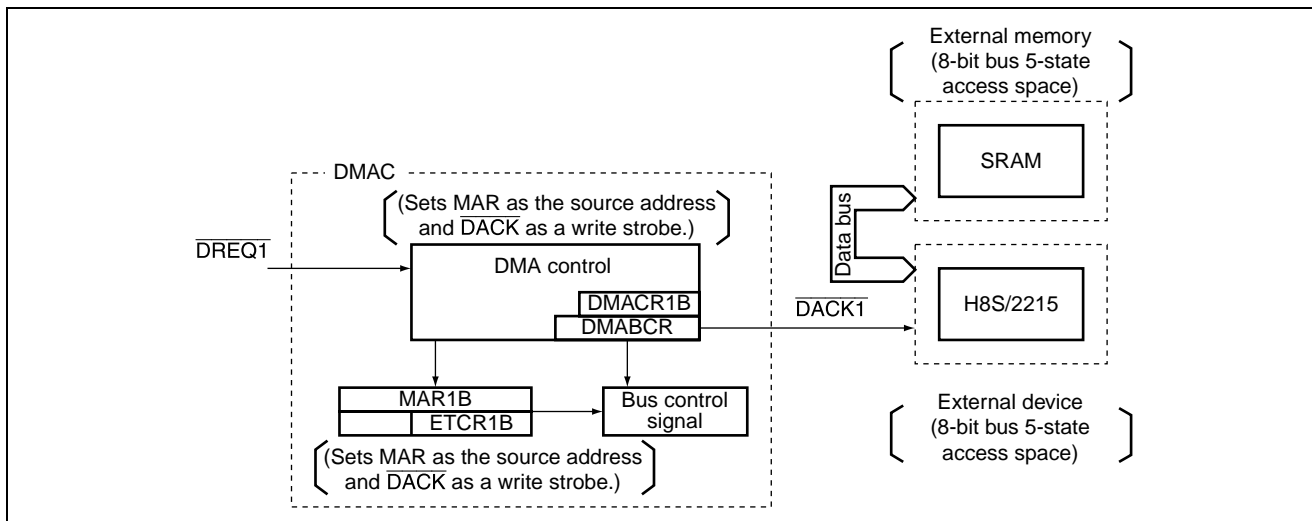

Figure 2 Block Diagram of DMA Controller

2. Function allocation of this sample task is shown in table 1. This sample task allocates the H8S/2239 functions as shown in table 1 to transfer blocks.

Table 1 Assignment of Functions

Elements	Description
DREQ1	Inputs an external pulse that functions as a trigger for DMAC startup.
DACK1	Data transfer acknowledge
DMABCR	Controls operation of each channel.
DMACR1B	Sets DMAC in the idle mode.
MAR1B	Sets the transfer source address.
ETCR1B	Sets a transfer count.

**3. Principles of Operation**

The principles of operations used are shown in figure 3. This sample task performs H8S/2239 hardware processing and software processing as shown in figure 3 to transfer one byte to the 8-bit 5-state access space in the external device from the external 8-bit 5-state access space.

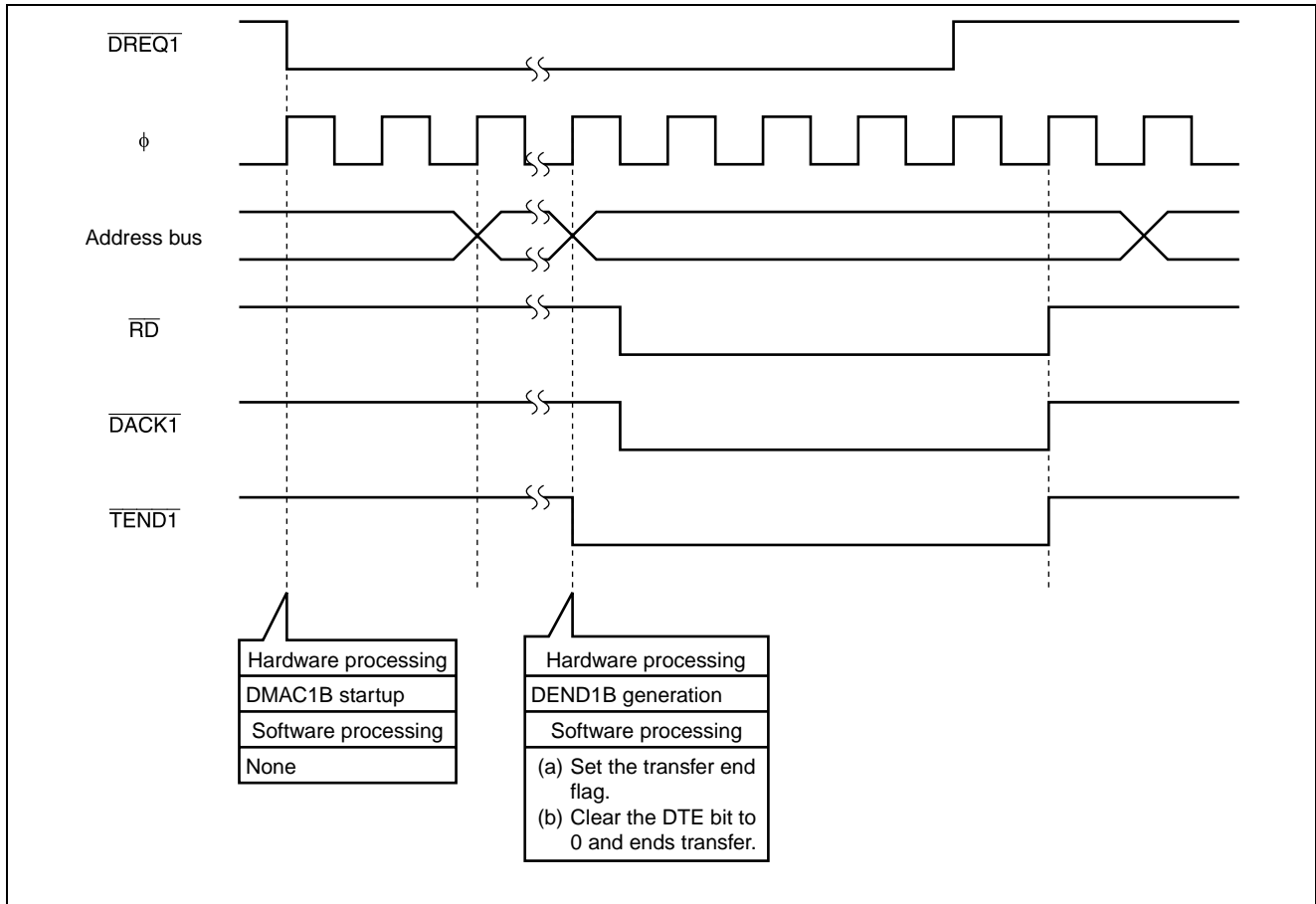

**Figure 3 Principles of Operations Used of Transfer in the Single-Address Mode (Byte Read)**

## 4. Description of Software

### 1. Description of Modules

Module Name	Label Name	Function
Main routine	singlemn	Performs initial setting of DMAC.
Data transfer end	transend	Sets the transfer end flag.

### 2. Description of Arguments

Elements	Function	Data Length	Used in	I/O
status	Flag indicating data transfer end	unsigned char	Main routine	Input
	1: Transfer ended 0: Transfer in progress		Transfer end	Output

### 3. Description of Internal Registers Used

Register Name	Function	Used in
DMABCRH	Sets DMAC1B in the single-address mode of the short-address mode.	Main routine
DMABCRL	Enables data transfer.	Main routine
DMACR1B	Sets DMACR as follows: <ul style="list-style-type: none"> <li>• Byte size transfer</li> <li>• Idle mode</li> <li>• Increment MAR after data transfer</li> <li>• Data transfer direction (MAR is set as the source address and the DACK pin as a write strobe.)</li> <li>• Falling edge of the DREQ signal is set as the startup source.</li> </ul>	Main routine
MAR1B	Sets the transfer source address.	Main routine
ETCR	Sets a transfer count.	Main routine
MSTPCR	Cancels DMAC module stop mode.	Main routine

### 4. RAM Usage

Table below describes RAM usage in this sample task.

Elements	Function	Data Length	Used in
transdata	Sets data to be transmitted.	unsigned char	Main routine

### 5. PAD

#### 1. Main Routine

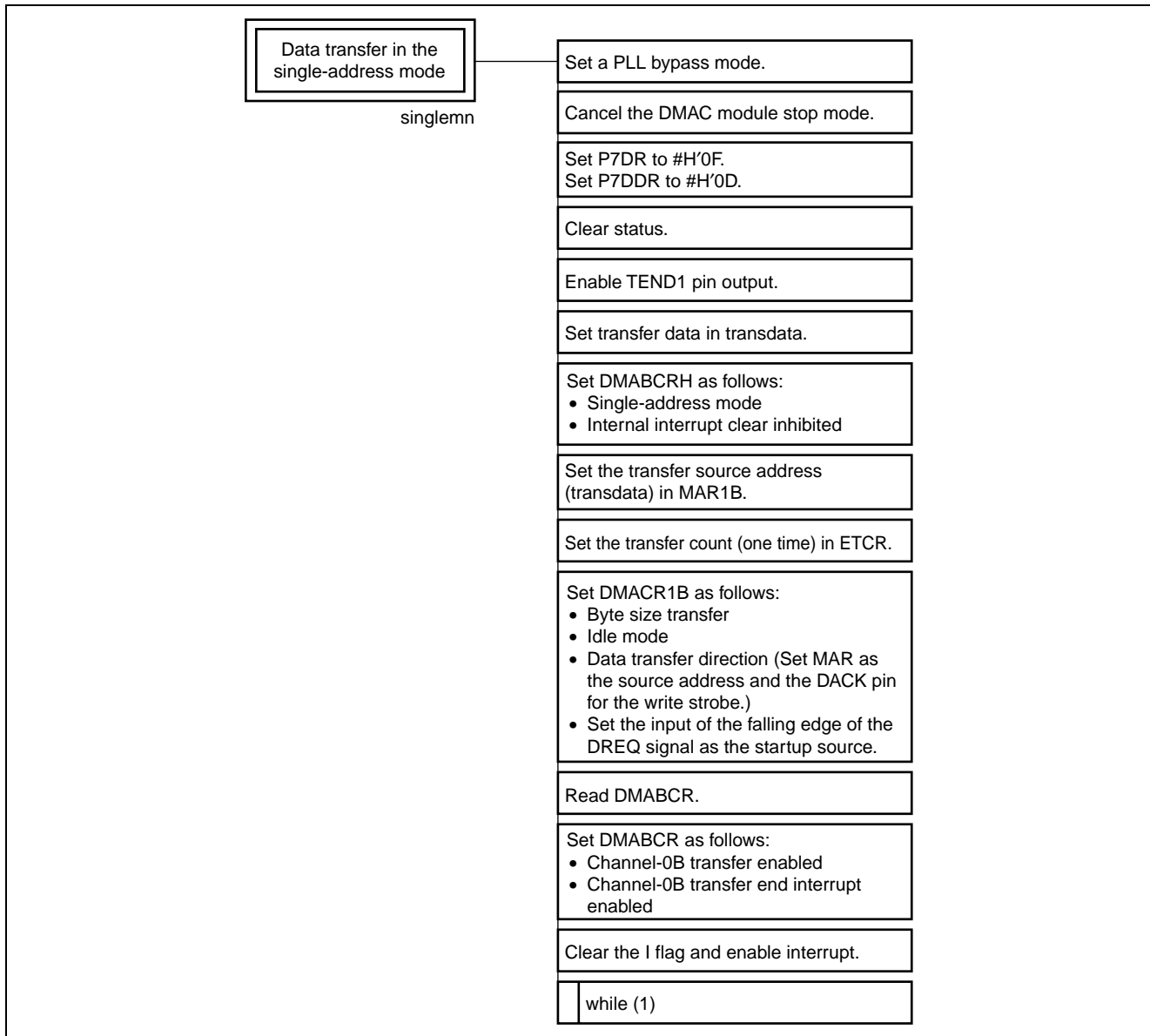

#### 2. Data Transfer End

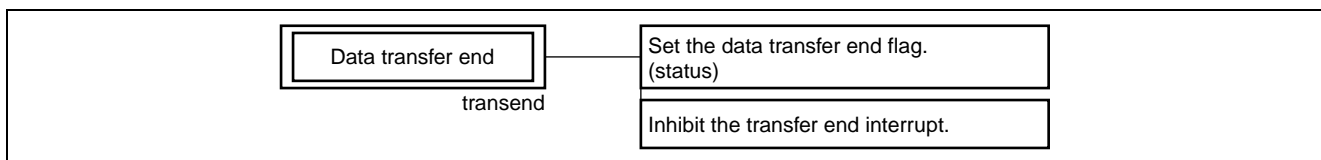

### Revision Record

Rev.	Date	Description	
		Page	Summary
1.00	Mar.16.04	—	First edition issued

Keep safety first in your circuit designs!

1. Renesas Technology Corp. puts the maximum effort into making semiconductor products better and more reliable, but there is always the possibility that trouble may occur with them. Trouble with semiconductors may lead to personal injury, fire or property damage. Remember to give due consideration to safety when making your circuit designs, with appropriate measures such as (i) placement of substitutive, auxiliary circuits, (ii) use of nonflammable material or (iii) prevention against any malfunction or mishap.

Notes regarding these materials

1. These materials are intended as a reference to assist our customers in the selection of the Renesas Technology Corp. product best suited to the customer's application; they do not convey any license under any intellectual property rights, or any other rights, belonging to Renesas Technology Corp. or a third party.
2. Renesas Technology Corp. assumes no responsibility for any damage, or infringement of any third-party's rights, originating in the use of any product data, diagrams, charts, programs, algorithms, or circuit application examples contained in these materials.
3. All information contained in these materials, including product data, diagrams, charts, programs and algorithms represents information on products at the time of publication of these materials, and are subject to change by Renesas Technology Corp. without notice due to product improvements or other reasons. It is therefore recommended that customers contact Renesas Technology Corp. or an authorized Renesas Technology Corp. product distributor for the latest product information before purchasing a product listed herein.  
The information described here may contain technical inaccuracies or typographical errors. Renesas Technology Corp. assumes no responsibility for any damage, liability, or other loss rising from these inaccuracies or errors.  
Please also pay attention to information published by Renesas Technology Corp. by various means, including the Renesas Technology Corp. Semiconductor home page (<http://www.renesas.com>).
4. When using any or all of the information contained in these materials, including product data, diagrams, charts, programs, and algorithms, please be sure to evaluate all information as a total system before making a final decision on the applicability of the information and products. Renesas Technology Corp. assumes no responsibility for any damage, liability or other loss resulting from the information contained herein.
5. Renesas Technology Corp. semiconductors are not designed or manufactured for use in a device or system that is used under circumstances in which human life is potentially at stake. Please contact Renesas Technology Corp. or an authorized Renesas Technology Corp. product distributor when considering the use of a product contained herein for any specific purposes, such as apparatus or systems for transportation, vehicular, medical, aerospace, nuclear, or undersea repeater use.
6. The prior written approval of Renesas Technology Corp. is necessary to reprint or reproduce in whole or in part these materials.
7. If these products or technologies are subject to the Japanese export control restrictions, they must be exported under a license from the Japanese government and cannot be imported into a country other than the approved destination.  
Any diversion or reexport contrary to the export control laws and regulations of Japan and/or the country of destination is prohibited.
8. Please contact Renesas Technology Corp. for further details on these materials or the products contained therein.