

To all our customers

---

## **Regarding the change of names mentioned in the document, such as Hitachi Electric and Hitachi XX, to Renesas Technology Corp.**

---

The semiconductor operations of Mitsubishi Electric and Hitachi were transferred to Renesas Technology Corporation on April 1st 2003. These operations include microcomputer, logic, analog and discrete devices, and memory chips other than DRAMs (flash memory, SRAMs etc.) Accordingly, although Hitachi, Hitachi, Ltd., Hitachi Semiconductors, and other Hitachi brand names are mentioned in the document, these names have in fact all been changed to Renesas Technology Corp. Thank you for your understanding. Except for our corporate trademark, logo and corporate statement, no changes whatsoever have been made to the contents of the document, and these changes do not constitute any alteration to the contents of the document itself.

Renesas Technology Home Page: <http://www.renesas.com>

Renesas Technology Corp.  
Customer Support Dept.  
April 1, 2003

H8/3437 Series QFP-100B,TQFP-100B  
User System Interface Cable  
(HS3437ECH61H)  
for E6000 Emulator

User's Manual

**HITACHI**

Preliminary,  
Rev. 0.1  
9/6/00  
Hitachi, Ltd.  
McS-Setsu



HS3437ECH61HE(B)



# IMPORTANT INFORMATION

## READ FIRST

- **READ this user's manual before using this user system interface cable.**
- **KEEP the user's manual handy for future reference.**

**Do not attempt to use the user system interface cable until you fully understand its mechanism.**

### **User System Interface Cable:**

Throughout this document, the term "user system interface cable" shall be defined as the following product produced only by Hitachi, Ltd. excluding all subsidiary products.

- User system interface cable (HS3437ECH61H)

The user system or a host computer is not included in this definition.

### **Purpose of the User System Interface Cable:**

This user system interface cable is for connecting the emulator station and user system. This user system interface cable must only be used for the above purpose.

### **Improvement Policy:**

Hitachi, Ltd. (including its subsidiaries, hereafter collectively referred to as Hitachi) pursues a policy of continuing improvement in design, performance, functions, and safety of the user system interface cable. Hitachi reserves the right to change, wholly or partially, the specifications, design, user's manual, and other documentation at any time without notice.

### **Target User of the User System Interface Cable:**

This user system interface cable should only be used by those who have carefully read and thoroughly understood the information and restrictions contained in the user's manual. Do not attempt to use the user system interface cable until you fully understand its mechanism.

It is highly recommended that first-time users be instructed by users that are well versed in the operation of the user system interface cable.

## **LIMITED WARRANTY**

Hitachi warrants its emulator products to be manufactured in accordance with published specifications and free from defects in material

and/or workmanship. Hitachi, at its option, will repair or replace any emulator products returned intact to the factory, transportation charges prepaid, which Hitachi, upon inspection, determine to be defective in material and/or workmanship. The foregoing shall constitute the sole remedy for any breach of Hitachi's warranty. See the Hitachi warranty booklet for details on the warranty period. This warranty extends only to you, the original Purchaser. It is not transferable to anyone who subsequently purchases the emulator product from you. Hitachi is not liable for any claim made by a third party or made by you for a third party.

## **DISCLAIMER**

HITACHI MAKES NO WARRANTIES, EITHER EXPRESS OR IMPLIED, ORAL OR WRITTEN, EXCEPT AS PROVIDED HEREIN, INCLUDING WITHOUT LIMITATION THEREOF, WARRANTIES AS TO MARKETABILITY, MERCHANTABILITY, FITNESS FOR ANY PARTICULAR PURPOSE OR USE, OR AGAINST INFRINGEMENT OF ANY PATENT. IN NO EVENT SHALL HITACHI BE LIABLE FOR ANY DIRECT, INCIDENTAL OR CONSEQUENTIAL DAMAGES OF ANY NATURE, OR LOSSES OR EXPENSES RESULTING FROM ANY DEFECTIVE EMULATOR PRODUCT, THE USE OF ANY EMULATOR PRODUCT, OR ITS DOCUMENTATION, EVEN IF ADVISED OF THE POSSIBILITY OF SUCH DAMAGES. EXCEPT AS EXPRESSLY STATED OTHERWISE IN THIS WARRANTY, THIS EMULATOR PRODUCT IS SOLD "AS IS", AND YOU MUST ASSUME ALL RISK FOR THE USE AND RESULTS OBTAINED FROM THE EMULATOR PRODUCT.

**State Law:**

Some states do not allow the exclusion or limitation of implied warranties or liability for incidental or consequential damages, so the above limitation or exclusion may not apply to you. This warranty gives you specific legal rights, and you may have other rights which may vary from state to state.

**The Warranty is Void in the Following Cases:**

Hitachi shall have no liability or legal responsibility for any problems caused by misuse, abuse, misapplication, neglect, improper handling, installation, repair or modifications of the user system interface cable without Hitachi's prior written consent or any problems caused by the user system.

**All Rights Reserved:**

This user's manual and user system interface cable are copyrighted and all rights are reserved by Hitachi. No part of this user's manual, all or part, may be reproduced or duplicated in any form, in hard-copy or machine-readable form, by any means available without Hitachi's prior written consent.

**Other Important Things to Keep in Mind:**

1. Circuitry and other examples described herein are meant merely to indicate the characteristics and performance of Hitachi's semiconductor products. Hitachi assumes no responsibility for any intellectual property claims or other problems that may result from applications based on the examples described herein.
2. No license is granted by implication or otherwise under any patents or other rights of any third party or Hitachi.

**Figures:**

Some figures in this user's manual may show items different from your actual system.

**Limited Anticipation of Danger:**

Hitachi cannot anticipate every possible circumstance that might involve a potential hazard. The warnings in this user's manual and on the user system interface cable are therefore not all inclusive. Therefore, you must use the emulator product safely at your own risk.

# SAFETY PAGE

## READ FIRST

- **READ** this user's manual before using this user system interface cable.
- **KEEP** the user's manual handy for future reference.

Do not attempt to use the user system interface cable until you fully understand its mechanism.

## DEFINITION OF SIGNAL WORDS



This is the safety alert symbol. It is used to alert you to potential personal injury hazards. Obey all safety messages that follow this symbol to avoid possible injury or death.



**DANGER** indicates an imminently hazardous situation which, if not avoided, will result in death or serious injury.



**WARNING** indicates a potentially hazardous situation which, if not avoided, could result in death or serious injury.



**CAUTION** indicates a potentially hazardous situation which, if not avoided, may result in minor or moderate injury.



**CAUTION** used without the safety alert symbol indicates a potentially hazardous situation which, if not avoided, may result in property damage.

**NOTE** emphasizes essential information.

## **WARNING**

**Observe the precautions listed below. Failure to do so will result in a FIRE HAZARD and will damage the user system and the emulator product or will result in PERSONAL INJURY. The USER PROGRAM will be LOST.**

- 1. Do not repair or remodel the emulator product by yourself for electric shock prevention and quality assurance.**
- 2. Always switch OFF the E6000 emulator and user system before connecting or disconnecting any CABLES or PARTS.**
- 3. Always before connecting any CABLES, make sure that pin 1 on both sides are correctly aligned.**
- 4. Supply power according to the power specifications and do not apply an incorrect power voltage. Use only the provided power cable.**

## Cautions

1. Hitachi neither warrants nor grants licenses of any rights of Hitachi's or any third party's patent, copyright, trademark, or other intellectual property rights for information contained in this document. Hitachi bears no responsibility for problems that may arise with third party's rights, including intellectual property rights, in connection with use of the information contained in this document.
2. Products and product specifications may be subject to change without notice. Confirm that you have received the latest product standards or specifications before final design, purchase or use.
3. Hitachi makes every attempt to ensure that its products are of high quality and reliability. However, contact Hitachi's sales office before using the product in an application that demands especially high quality and reliability or where its failure or malfunction may directly threaten human life or cause risk of bodily injury, such as aerospace, aeronautics, nuclear power, combustion control, transportation, traffic, safety equipment or medical equipment for life support.
4. Design your application so that the product is used within the ranges guaranteed by Hitachi particularly for maximum rating, operating supply voltage range, heat radiation characteristics, installation conditions and other characteristics. Hitachi bears no responsibility for failure or damage when used beyond the guaranteed ranges. Even within the guaranteed ranges, consider normally foreseeable failure rates or failure modes in semiconductor devices and employ systemic measures such as fail-safes, so that the equipment incorporating Hitachi product does not cause bodily injury, fire or other consequential damage due to operation of the Hitachi product.
5. This product is not designed to be radiation resistant.
6. No one is permitted to reproduce or duplicate, in any form, the whole or part of this document without written approval from Hitachi.
7. Contact Hitachi's sales office for any questions regarding this document or Hitachi semiconductor products.







## Preface

Thank you for purchasing the E6000 emulator for the Hitachi's original microprocessor H8/300 series.

The HS3437ECH61H is a user system interface cable that connects an H8/300 series E6000 emulator (HS3008EPI60H; hereinafter referred to as the emulator) to the IC socket for a QFP-100B or TQFP-100B package (package code: FP-100B or TFP-100B) for the H8/3437 series MCU on the user system.

# Contents

Section 1	Configuration .....	1
Section 2	Connection Procedures .....	3
2.1	Connecting User System Interface Cable to Emulator Station .....	3
2.2	Connecting User System Interface Cable to User System .....	5
2.2.1	Installing IC Socket .....	5
2.2.2	Soldering IC Socket.....	5
2.2.3	Inserting Cable Head .....	5
2.2.4	Fastening Cable Head.....	6
2.2.5	Fastening Cable Body.....	8
2.3	Recommended Dimensions for User System Mount Pad .....	9
2.4	Dimensions for User System Interface Cable Head.....	10
2.5	Resulting Dimensions after Connecting User System Interface Cable .....	11
Section 3	Installing the MCU to the User System .....	12
Section 4	Verifying Operation .....	14
Section 5	Notice .....	15

Section 1 Configuration

**CAUTION**

**Use an IC149-100-054-B51 socket (manufactured by YAMAICHI ELECTRONICS Co., Ltd.) for the FP-100B or TFP-100B package IC socket on the user system.**

Figure 1 shows the configuration of the HS3437ECH61H user system interface cable for the FP-100B or TFP-100B package.

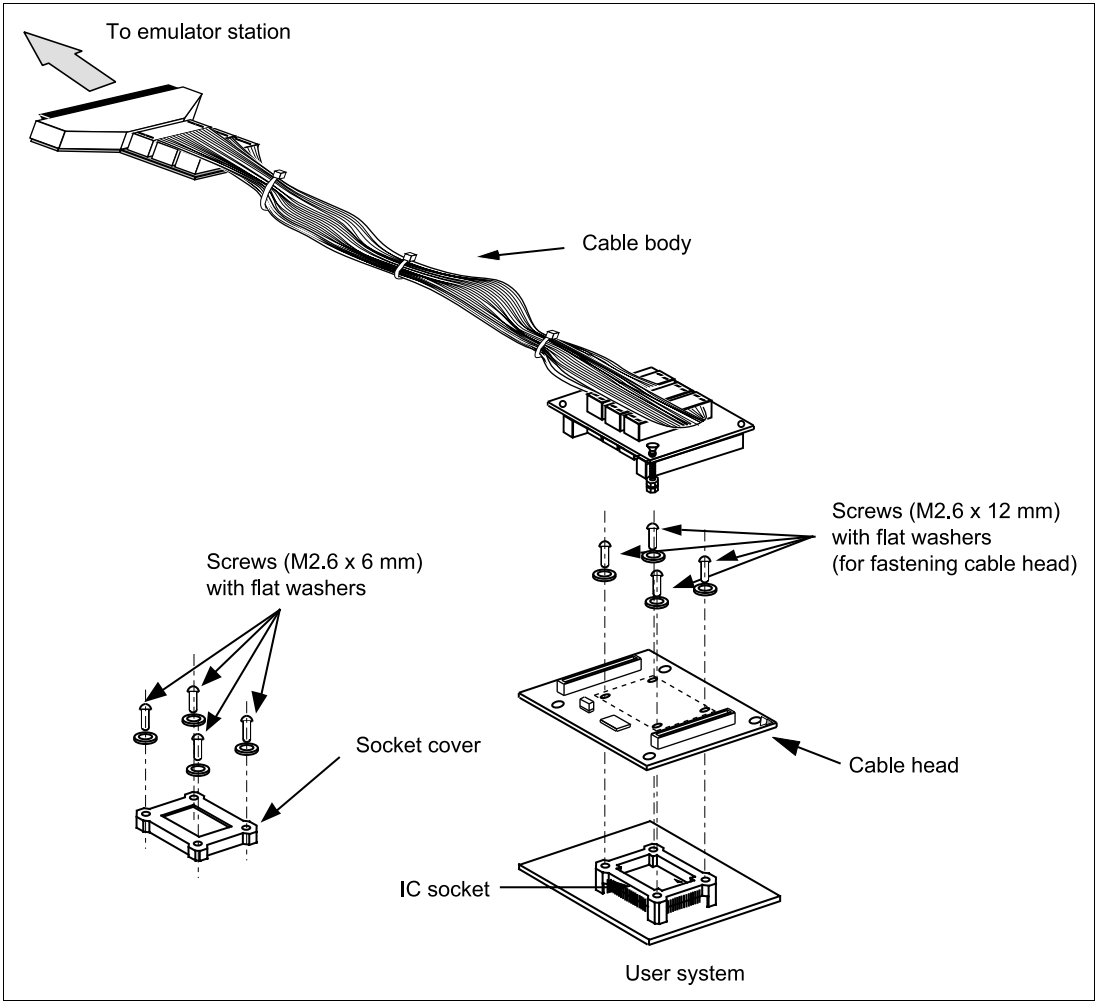

Figure 1 HS3437ECH61H User System Interface Cable

Table 1 lists the HS3437ECH61H components. Please make sure you have all of these components when unpacking.

**Table 1 HS3437ECH61H Components**

<b>No.</b>	<b>Component</b>	<b>Quantity</b>	<b>Remarks</b>
1	Cable body	1	Flat cable
2	Cable head	1	
3	IC socket	1	For the FP-100B or TFP100-B package
4	Socket cover	1	For installing an FP-100B or TFP-100B packaged MCU
5	Screws (M2.6 x 12 mm)	4	For fastening cable head (with four flat washers)
6	Screws (M2.6 x 6 mm)	4	For installing an FP-100B or TFP-100B packaged MCU (with four flat washers)
7	Documentation	1	User's manual for HS3437ECH61H (this manual)

## Section 2 Connection Procedures

### 2.1 Connecting User System Interface Cable to Emulator Station

#### **WARNING**

**Observe the precautions listed below. Failure to do so will result in a FIRE HAZARD and will damage the user system and the emulator product or will result in PERSONAL INJURY. The USER PROGRAM will be LOST.**

- 1. Always switch OFF the user system and the emulator product before the USER SYSTEM INTERFACE CABLE is connected to or removed from any part. Before connecting, make sure that pin 1 on both sides are correctly aligned.**
- 2. The user system interface cable dedicated to the emulator must be used.**

To connect the cable body to the emulator station, follow the instructions below.

1. Make sure the user system and emulator station are turned off.
2. After making sure the direction of the cable body connector is correct, firmly insert the cable body connector into the emulator station socket (figure 2).

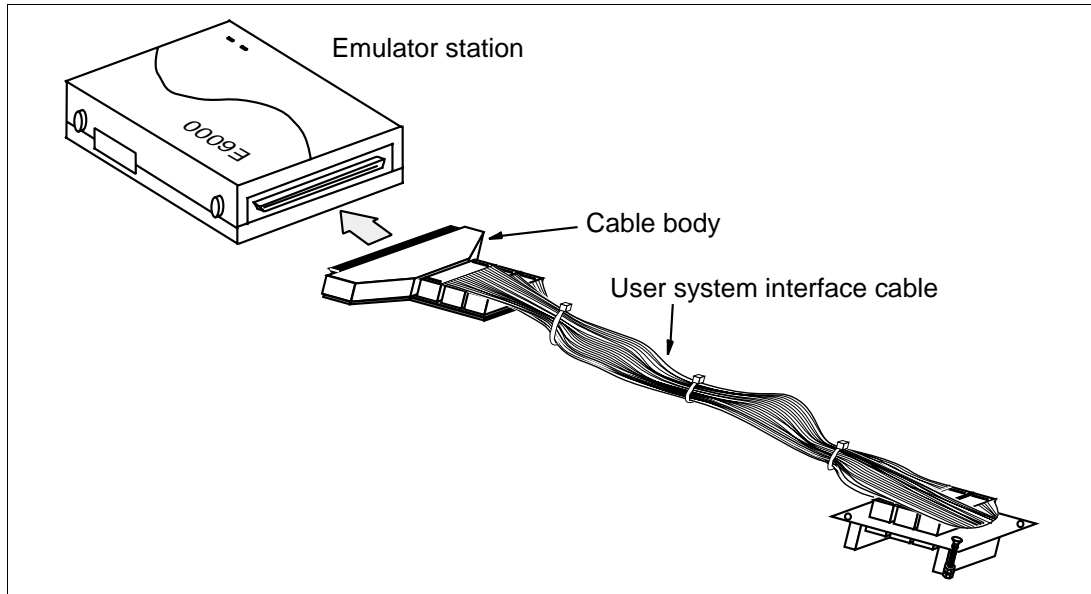

**Figure 2 Connecting User System Interface Cable to Emulator Station**

## 2.2 Connecting User System Interface Cable to User System

### **WARNING**

**Always switch OFF the user system and the emulator product before the USER SYSTEM INTERFACE CABLE is connected to or removed from any part. Before connecting, make sure that pin 1 on both sides are correctly aligned. Failure to do so will result in a FIRE HAZARD and will damage the user system and the emulator product or will result in PERSONAL INJURY. The USER PROGRAM will be LOST.**

To connect the cable head to the user system, follow the instructions below.

#### 2.2.1 Installing IC Socket

After checking the location of pin 1 on the IC socket, apply epoxy resin adhesive to the bottom of the IC socket for an FP-100B or TFP-100B package, and fasten it to the user system.

#### 2.2.2 Soldering IC Socket

After fastening, solder the IC socket for an FP-100B or TFP-100B package to the user system. Be sure to completely solder the leads so that the solder slopes gently over the leads and forms solder fillets. (Use slightly more solder than the MCU.)

#### 2.2.3 Inserting Cable Head

### **CAUTION**

**Check the location of pin 1 before inserting.**

Align pin 1 on the IC socket for an FP-100B or TFP-100B package on the user system with pin 1 on the user system interface cable head, and insert the user system interface cable head into the IC socket on the user system, as shown in figure 3.

#### 2.2.4 Fastening Cable Head

## CAUTION

1. Use a Phillips-type screwdriver whose head matches the screw head.
2. The tightening torque must be 0.294 N•m or less. If the applied torque cannot be accurately measured, stop tightening when the force required to turn the screw becomes significantly greater than that needed when first tightening. If a screw is tightened too much, the screw head may break or a socket contact error may be caused by a crack in the socket solder.
3. If the emulator does not operate correctly, cracks might have occurred in the solder. Check conduction with a tester and re-solder the socket if necessary.

Fasten the user system interface cable head to the IC socket for an FP-100B or TFP-100B package on the user system with the four screws (M2.6 x 12 mm with flat washers) provided. Each screw should be tightened a little at a time, alternating between screws on opposing corners. Take special care, such as manually securing the IC socket soldered area, to prevent the soldered IC socket from being damaged by overtightening the screws or twisting the components.

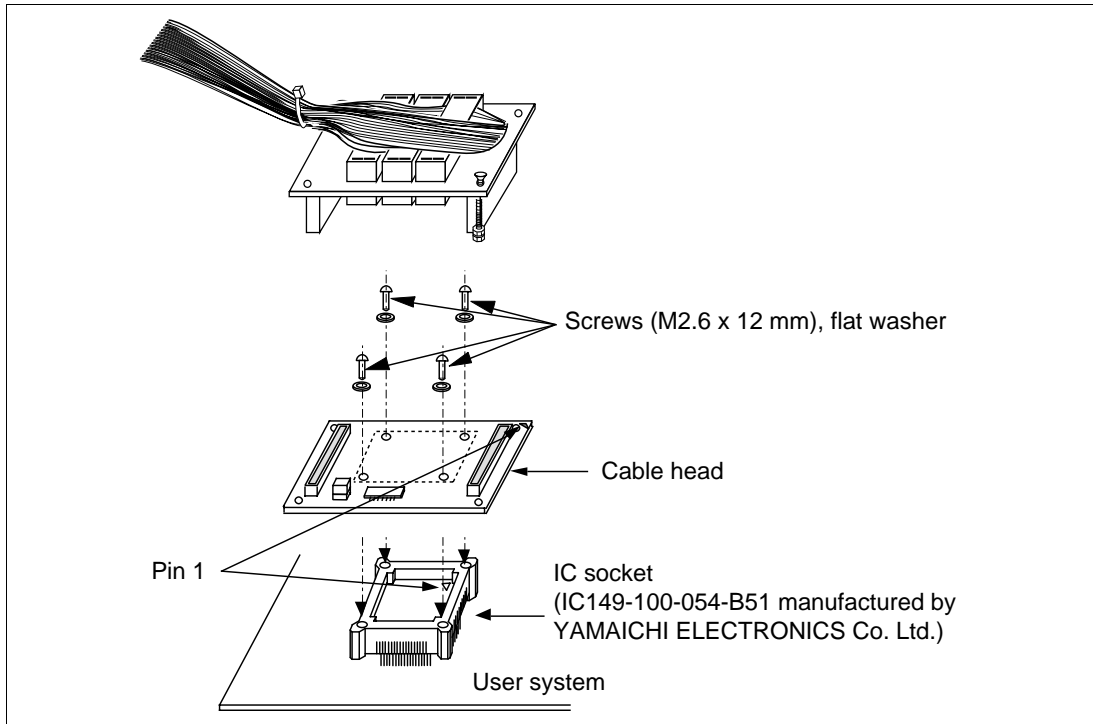

**Figure 3 Connecting User System Interface Cable to User System**

### 2.2.5 Fastening Cable Body

Connect the cable body to the cable head.

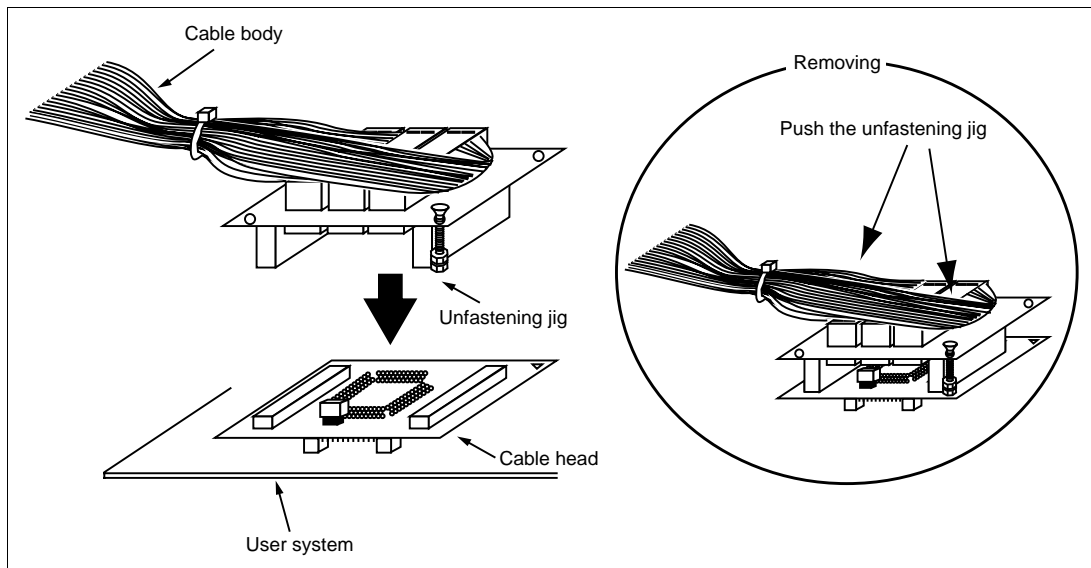

Figure 4 Fastening Cable Body

### 2.3 Recommended Dimensions for User System Mount Pad

Figure 5 shows the recommended dimensions for the mount pad (footprint) for the user system with an IC socket for an FP-100B or TFP-100B package (IC149-100-054-B51: manufactured by YAMAICHI ELECTRONICS Co., Ltd.). Note that the dimensions in figure 5 are somewhat different from those of the actual chip's mount pad.

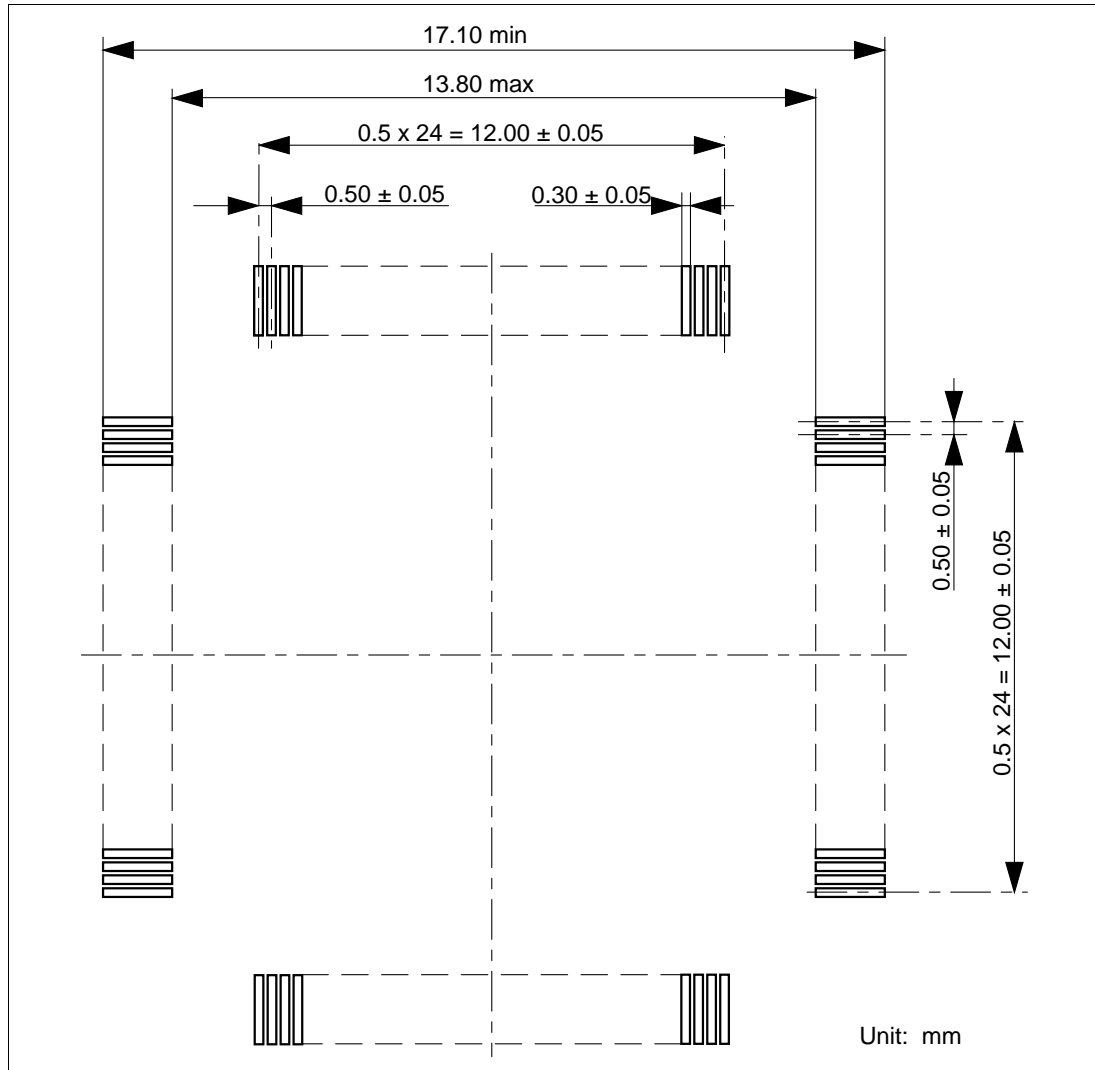

Figure 5 Recommended Dimensions for Mount Pad

## 2.4 Dimensions for User System Interface Cable Head

The dimensions for the user system interface cable head are shown in figure 6.

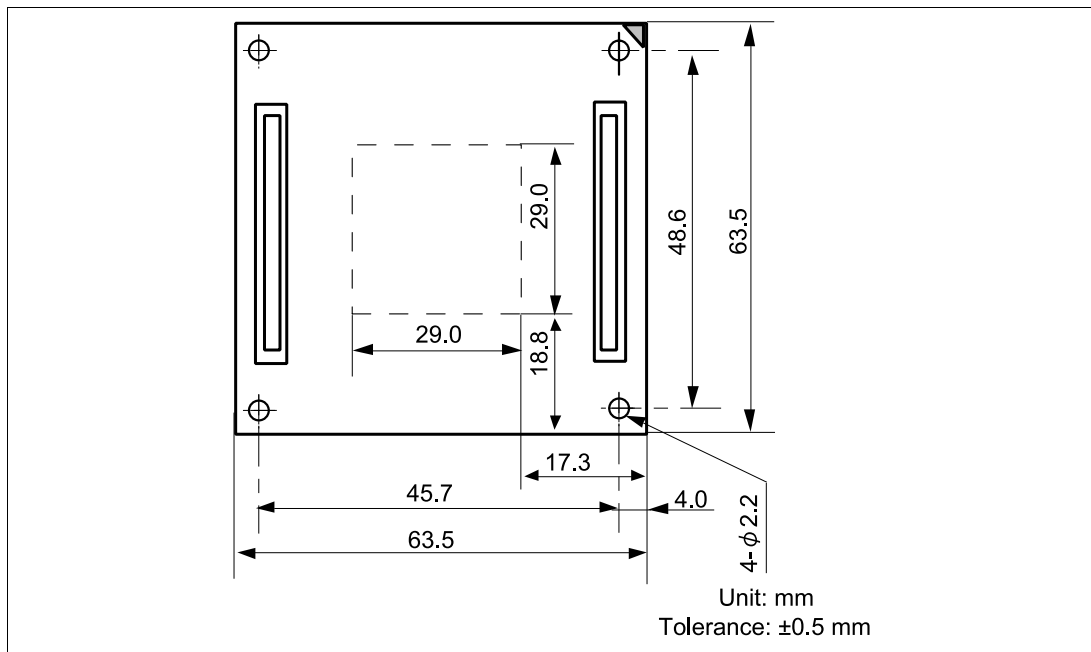
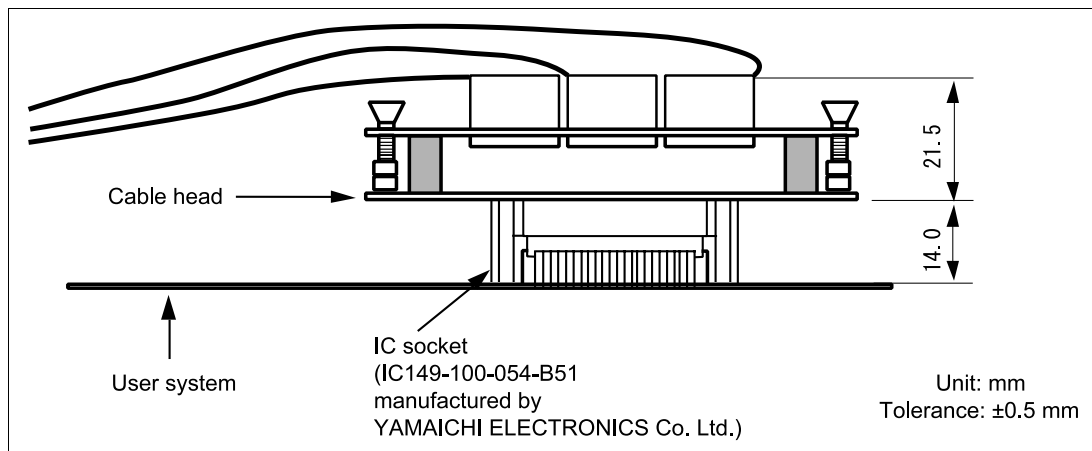

Figure 6 Dimensions for User System Interface Cable Head

## 2.5 Resulting Dimensions after Connecting User System Interface Cable

The resulting dimensions, after connecting the user system interface cable head to the user system, are shown in figure 7.



**Figure 7 Resulting Dimensions after Connecting User System Interface Cable**

## Section 3 Installing the MCU to the User System

### **CAUTION**

- 1. Check the location of pin 1 before inserting.**
- 2. Use a Phillips-type screwdriver whose head matches the screw head.**
- 3. The tightening torque must be 0.294 N•m or less.  
If the applied torque cannot be accurately measured, stop tightening when the force required to turn the screw becomes significantly greater than that needed when first tightening. If a screw is tightened too much, the screw head may break or an IC socket contact error may be caused by a crack in the IC socket solder.**
- 4. If the MCU does not operate correctly, cracks might have occurred in the solder. Check conduction with a tester and re-solder the IC socket if necessary.**

Check the location of pin 1 before inserting the MCU into the IC socket on the user system, as shown in figure 8. After inserting the MCU, fasten the socket cover with the provided four screws (M2.6 x 6 mm with flat washers). Take special care, such as manually securing the IC socket soldered area, to prevent the IC socket from being damaged by overtightening the screws or twisting the components.

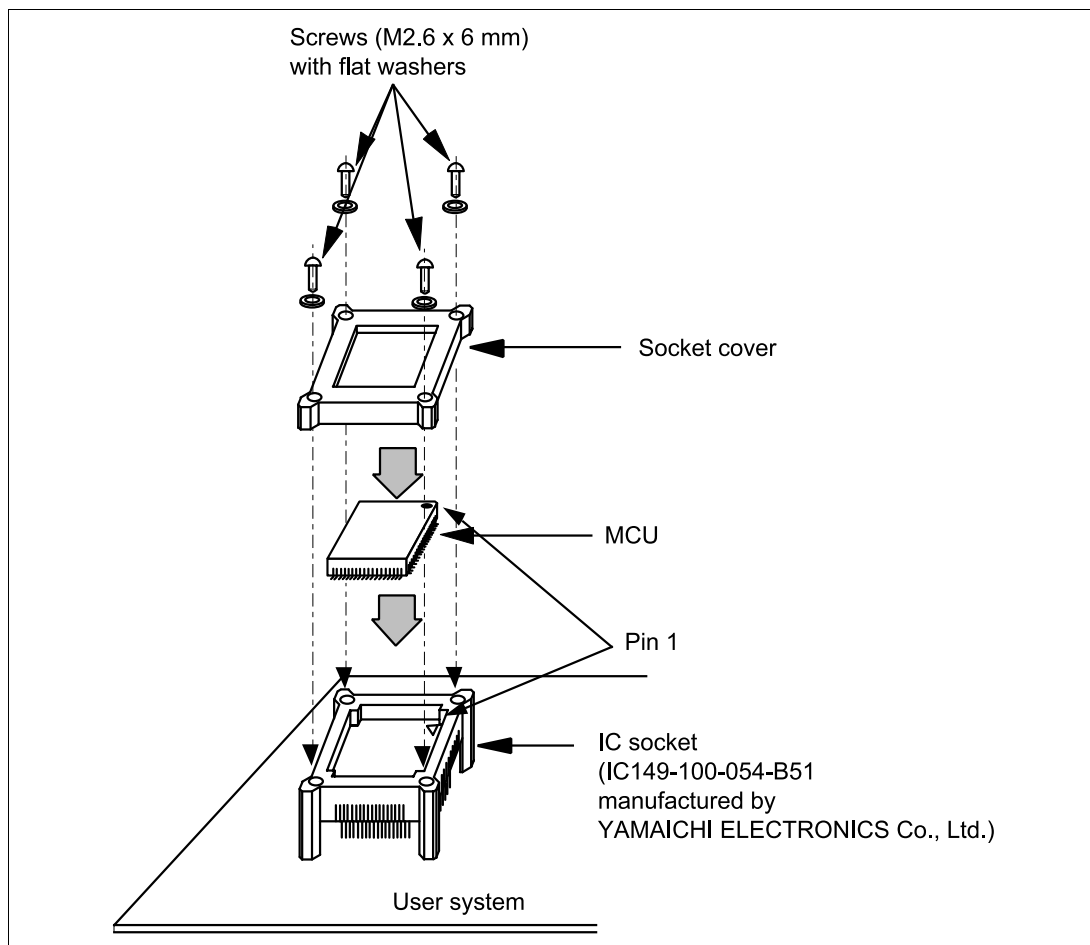

**Figure 8 Installing MCU to User System**

## Section 4 Verifying Operation

1. When using the H8/300 series E6000 emulator (HS3008EPI60H), turn on the emulator according to the procedures described in the H8/300 Series E6000 Emulator User's Manual (HS3008EPI60HE).
2. Verify the user system interface cable connections by accessing the external memory and ports to check the bus states of the pins. If an error is detected, recheck the soldered IC socket and the location of pin 1.
3. The emulator connected to this user system interface cable supports two kinds of clock sources: an emulator internal clock and an external clock on the user system. For details, refer to the H8/300 Series E6000 Emulator User's Manual (HS3008EPI60HE).

— To use the emulator internal clock

Select the clock in the emulator station as the system clock ( $\phi$ ), by using the CLOCK command (emulator command).

— To use the external clock on the user system as the system clock

Select target clock t with the CLOCK command (emulator command). Supply the external clock from the user system to the emulator. Insert a crystal oscillator into the EXTAL and XTAL terminals for the system clock. The system clock ( $\phi$ ) has the same frequency as the external clock.

Figure 9 shows the oscillator circuit on the user system interface cable.

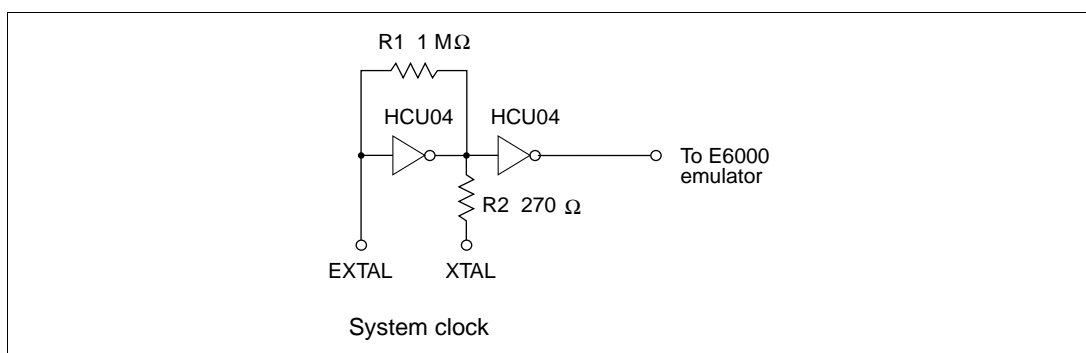

**Figure 9 Oscillator Circuit**

## Section 5 Notice

1. Make sure that pin 1 on the user system IC socket is correctly aligned with pin 1 on the cable head before inserting the cable head into the user system IC socket.
2. The dimensions of the recommended mount pad for the user system IC socket are different from those of the MCU.
3. This user system interface cable is specifically designed for the HS3008EPI60H emulator. Do not use this cable with any other emulator station.
4. To prevent breaking of wires in the cable body, do not place heavy or sharp metal objects on the user system interface cable.
5. While the emulator station is connected to the user system with the user system interface cable, force must not be applied to the cable head. Place the emulator station, user system interface cable, and user system as shown in the example in figure 10.

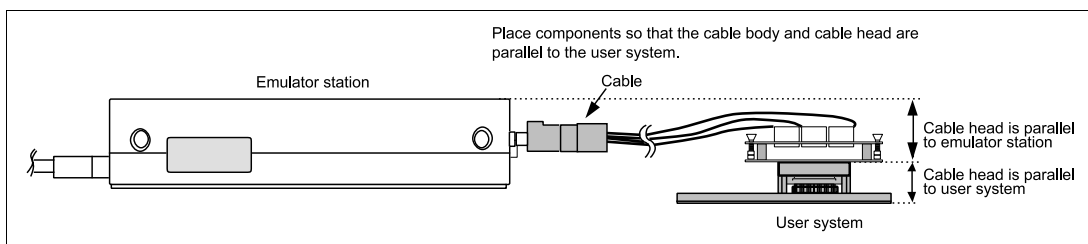

**Figure 10 User Cable Location Example**

6. The P1 short connector is used for testing. Do not remove the inserted jumper pin.

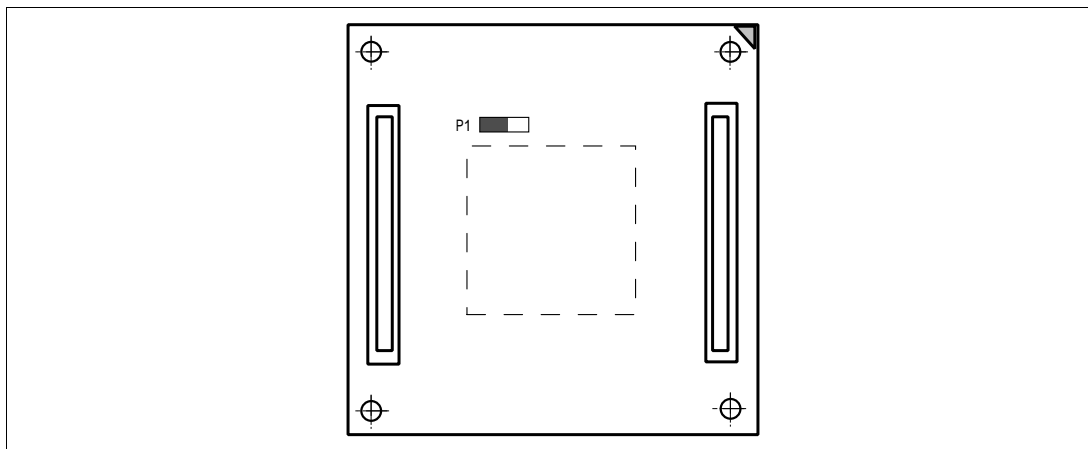

**Figure 11 P1 Short Connector**